

# Line Reactors and AC Drives.

By: John T. Streicher  
Rockwell Automation  
Mequon Wisconsin

Quite often, line and load reactors are installed on AC drives without a solid understanding of why or what the positive and negative consequences are for adding this piece of hardware. The purpose of this document is to provoke some thought on the part of the person(s) responsible for the successful installation of the drive, and to provide some guidelines as to if, where and when a reactor is needed and what size reactor to use.

## What Is A Reactor:

Let's first define what a reactor is. Essentially a reactor is an inductor. Physically it is simply a coil of wire that allows a magnetic field to form around the coil when current flows through it. When energized, it is an electric magnet with the strength of the field being proportional to the amperage flowing and the number of turns. A simple loop of wire is an air core inductor. More loops give a higher inductance rating. Quite often some ferrous material such as iron is added as a core to the winding. This has the effect of concentrating the lines of magnetic flux there by making a more effective Inductor.

Going back to basic AC circuit theory, an inductor has the characteristic of storing energy in the magnetic field and is reluctant to a change in current. The main property of a reactor is its inductance and is measured in henrys, millihenrys or microhenrys. In a DC circuit (such as that of the DC bus in an AC drive), an inductor simply limits the rate of change of current in the circuit since current in an inductor wants to continue to flow at the given rate for any instant in time. That is to say, an instantaneous increase or decrease in applied voltage will result in a slow increase or decrease in current. Conversely, if the rate of current in the inductor changes, a corresponding voltage will be induced. If we look at the equation  $V=L (di/dt)$  for an inductor where V is voltage, L is inductance and (di/dt) is the rate of change of current in amps per second, we can see that a positive rise in current will cause a voltage to be induced. This induced voltage is opposite in polarity to the applied voltage and proportional to both the rate of rise of current and the inductance value. This induced voltage subtracts from the applied voltage thereby limiting the rate of rise of current. This inductance value is a determining factor of the reactance. The reactance is part of the total impedance for an AC circuit. The equation for the reactance of an inductor is  $X_L = 2\pi FL$ . Where  $X_L$  is inductive reactance in Ohms, F is the applied frequency of the AC source and L is the inductance value of the reactor. As you can see, the reactance and therefor the impedance of the reactor is higher with a higher inductance value. Also, a given inductance value will have a higher impedance at higher frequencies. Thus we can say that in addition to limiting the rate of rise in current, a reactor adds impedance to an AC circuit proportional to both its inductance value and the applied frequency.

## Side-Effects of adding a Reactor:

Like most medication there are side-effects to using a reactor. Though these issues should not prevent the use of a reactor when one is required, the user should be aware of and ready to accommodate these effects. Since a reactor is made of wire (usually copper) wound in a coil, it will have the associated losses due to wire resistance. Also, if it is an Iron core inductor (as in the case of most reactors used in power electronics) it will have some "eddy current" loss in the core due to the changing magnetic field and the iron molecules being magnetically realigned. In general a reactor will add cost and weight, require space, generate heat and reduce efficiency.

Sometimes the addition of a line reactor can change the characteristics of the line you are connected to. Other components such as power factor correction capacitors and stray cable capacitance can interact with a line reactor causing a resonance to be set up. AC drives have exhibit a relatively good power factor and do not require the use of correction capacitors. In fact, power factor correction capacitors often do more harm than good where AC drives are present. For the most part, power factor correction capacitors should never be used with a drive. You may find that the addition of a reactor completes the required components for a line resonance where none previously existed, especially where power factor correction capacitors are present. In such cases either the capacitor or the inductor must be removed.

Furthermore, reactors have the effect of dropping some voltage, reducing the available voltage to the motor and or input of the motor drive.

One might ask; With all these side effects, why use a reactor? If you ask that question you might hear a whole slew of answers ranging from, "That's the way we always do it" to "I'd rather be safe than sorry." The fact is there are good reasons to install a reactor under certain conditions. Let's start with the input side of a drive.

### **A Reactor at the Input to reduce Harmonics:**

As you may already know, most standard "six pulse" drives are nonlinear loads. They tend to draw current only at the plus and minus peaks of the line. Since the current wave-form is not sinusoidal the current is said to contain "harmonics". For a standard 3 phase input converter (used to convert AC to DC) using six SCR's or six diodes and a filter capacitor bank as shown in figure 1a below, the three phase input current may contain as much as 85% or more total harmonic distortion. Notice the high peaks.

### 3 Phase Input

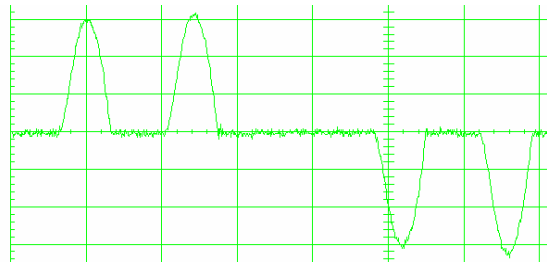
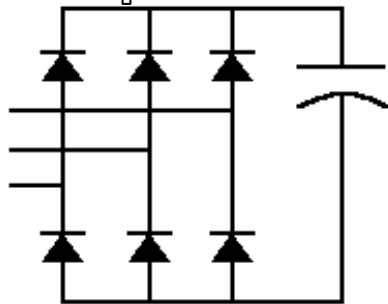

Figure 1a No reactor

### 3 Phase Input

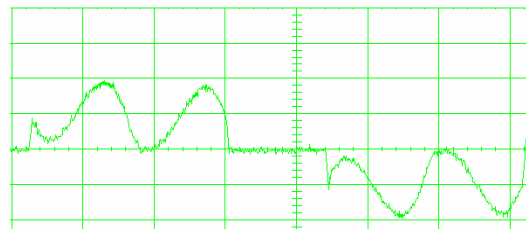
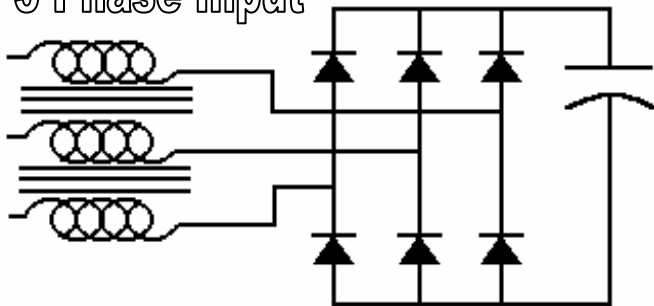

Figure 1b AC Line reactor

### 3 Phase Input

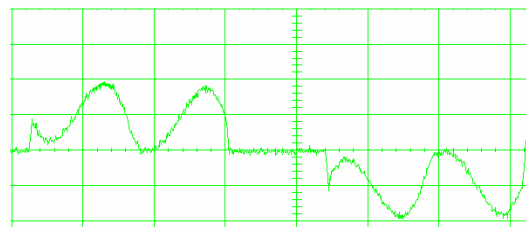
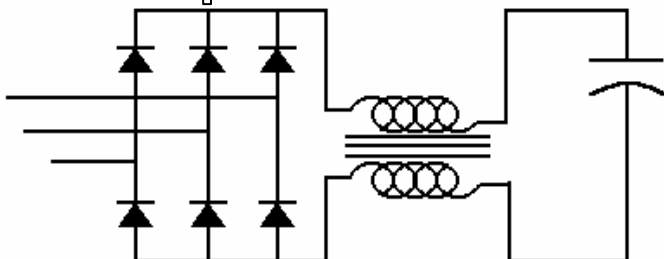

Figure 1c DC Link reactor

If a line reactor is installed as in figure 1b, the peaks of the line current are reduced and somewhat broadened out. This makes the current somewhat more sinusoidal, lowering the harmonic level to around 35% when a properly sized reactor is used. This effect is also beneficial to the DC filter capacitors. Since the “ripple current” is reduced. The capacitors can be smaller, run cooler and last longer. Though harmonic mitigation is an important reason to use a line reactor, most drives at the 10 horsepower rating and above include a “DC link choke” as seen in figure 1c. The link choke is a reactor put in the DC bus between the Rectifier bridge and the capacitor bank. It can provide the necessary harmonic mitigation and since it is in the DC bus, it can be made smaller and cheaper than the 3 phase input reactor.

**Small Drives may need an Input Reactor:**

Generally drives less than 10 hp do not have a dc link reactor. And in most cases that’s not a problem since any harmonic current distortion would be small when compared to the total load of the facility. If many small drives are required for a process, an input reactor is a valid method in reducing harmonics. In the case of many small drives, it is often more economical and practical to connect a group of 5 to 10 drives through one large three phase reactor as shown in figure 2.

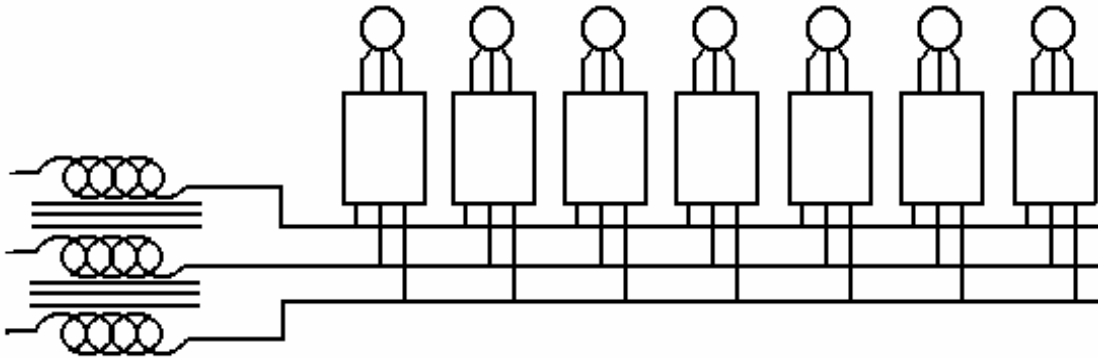

Figure 2

If there was ever a mandate to install an input reactor, it may be on a small drive where the transformer feeding it might be 20 times or more of the current or power rating of the drive. In some cases a large transformer (one with a low source impedance and or high short circuit capability) feeding a relatively small drive can result in overheating of the drive internal DC capacitor bank. When an NTC (negative temperature coefficient) pre-charge system is used, a large transformer feeding the drive can result in excessive inrush and clear line fuses or damage the drive. An input line reactor here will help. In this case, the reactor reduces harmonic current but the real reason for its’ presence is to limit the peak current that will flow at the input and in the capacitor bank.

**A Reactor as a line voltage buffer:**

In some cases, other switch gear on the line such as contactors and disconnects can cause line transients, particularly when inductive loads such as motors are switched off. In such cases, a voltage spike may occur at the input to the drive that could result in a surge of current at the input. If the voltage is high enough, a failure of the semiconductors in the DC converter may also result. Sometimes a reactor is used to “Buffer from the line”. While a DC link choke, if present, will protect against a current surge, it cannot protect the converter from a voltage spike since a link choke is located after the converter (refer to figure 1c). The Semiconductors are exposed to whatever line voltage condition exists. For this reason a reactor at the input to the drive may be of some help, but a better solution would be to attenuate the voltage spike at the source with a snubber circuit. Figure 3 shows both methods being used to protect the drive input semiconductors.

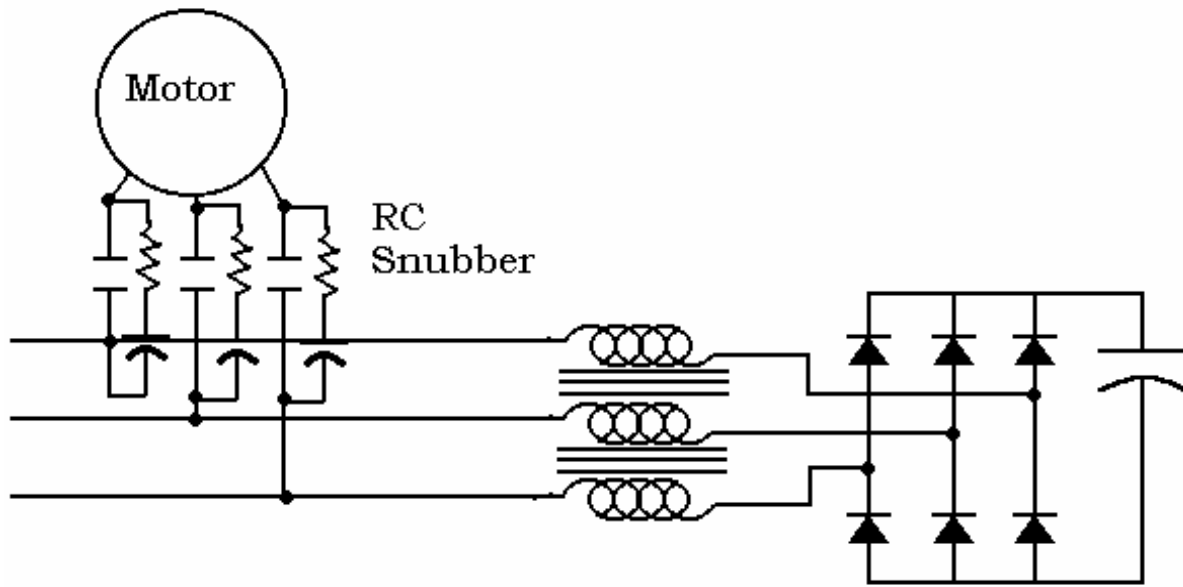

Figure 3

**A reactor does not fix grounding issues nor does it provide isolation.** Keep in mind that while a reactor provides some buffering, it does not provide isolation and can not take the place of an isolation transformer. If isolation is needed, an isolation transformer must be used. Contact your distributor for an appropriately sized transformer. Also, it must be stated that while a reactor can provide light buffering from a short duration (less than 1 ms) transient condition, it will not fix a high line condition or protect against line swells (high line for several line cycles). Nor should it be expected to protect against high energy short duration events such as lightning strikes.

**Reactors at the drive output to increase load inductance:**

Applying a reactor at the output of a drive is sometimes necessary. Again, all of the “side-effects” as previously stated hold true. And yes, there are a few instances when it may be necessary to add load impedance by inserting an output reactor. If the motor has a “low leakage inductance” a reactor can help bring the total load inductance back up to a level that the drive can handle. In the days of the “Bipolar transistor” drive, carrier frequencies rarely exceeded 1.5Khz. This meant that the transistor “On time” was much longer. This allowed current to ramp up higher, limited by the load or motor inductance. The result of a low inductance motor was huge ripple current that sometimes ran into the current limit of the drive causing poor performance or tripping. For the most part, the higher carrier frequencies and correspondingly lower ripple current of today’s IGBT (Isolated Gate Bipolar Transistor) drives have eliminated the need to add inductance to the load. Refer to the comparison in figure 4.

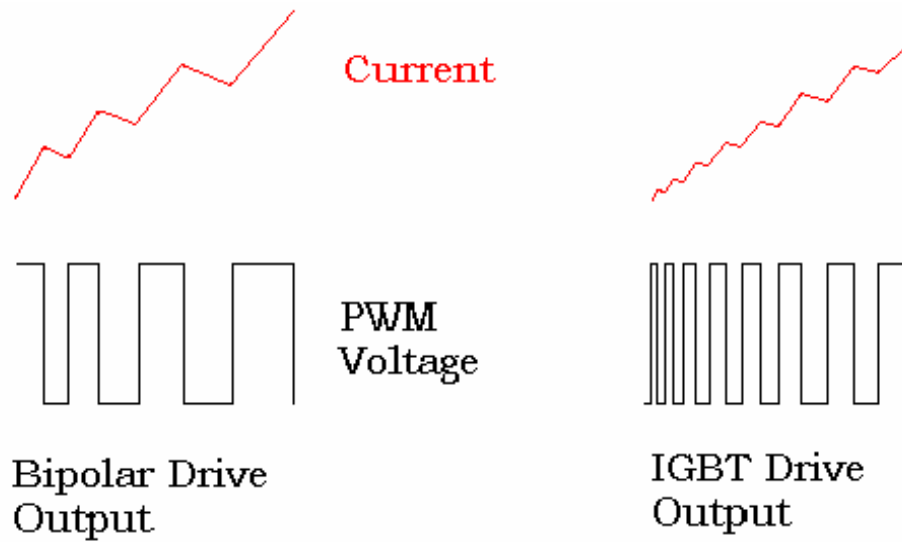

Figure 4

In some rare cases where a strange motor configuration or a motor with 6 or more poles is used, the motor inductance may be too low and a reactor may be needed. Running multiple motors on one drive may also result in a low inductance load and the requirement of an output reactor.

**Reactors at the drive output to reduce the effect of reflected wave:**

A reactor at the output of a drive is sometimes installed in order to prevent a reflected wave voltage spike when long motor leads are required. This is not always a good practice. Though the reactor will slope off the voltage rise time providing some benefit, it is not likely to limit the peak voltage at the motor. In some cases, a resonance can be set up between the cable capacitance and reactor that causes even higher voltages to be seen at the motor. In general, a motor terminator is a better solution. If a reactor is installed at the output, it is most likely part of a specially designed “reflected wave reduction” device that also has damping resistors in parallel. If a reactor is used at the output, it should be located as close to the drive end as is possible. Figure 5 shows the motor voltage before and after the installation of a reactor. The DC bus voltage is shown for reference. Notice that the rise times are different, the peak voltage is about twice the DC bus voltage regardless of the use of a reactor.

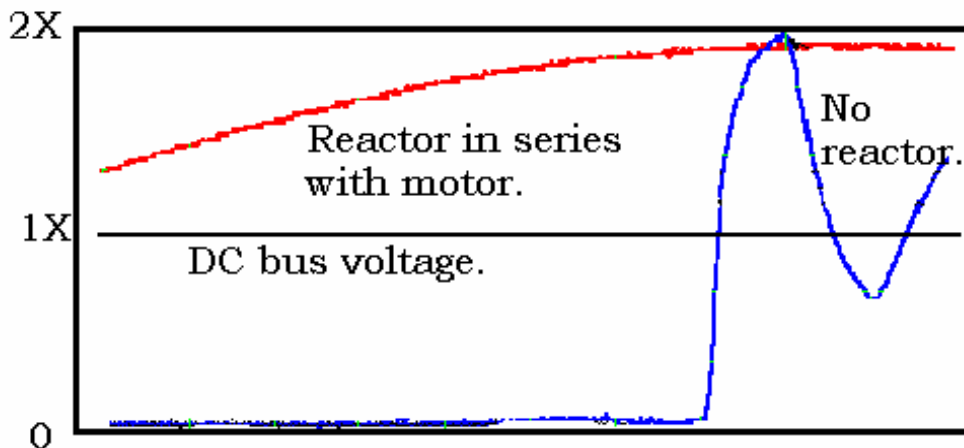

Figure 5

Since a current regulated drive requires “voltage margin” to regulate current, the output voltage is already limited by about 5%. Adding a reactor at the output will drop the voltage even further. A reactor at the output of this type of drive may not be a problem so long as the application can run without full motor voltage near full speed (typically 55 to 60 hertz). In some cases a specially wound motor may be used to compensate. For example a 460 volt 150 amp motor may be rewound as a 400 volt 175 amp motor.

### **Sizing a reactor:**

The first rule is make sure you have a high enough amp rating. In terms of the impedance value, you will usually find that 3% to 5% is the norm with most falling closer to 3%. A 3% reactor is enough to provide line buffering and a 5% reactor would be a better choice for harmonic mitigation if no link choke is present. Output reactors, when used, are generally around 3%. This % rating is relative to the load or drive where the reactor impedance is a % of the drive impedance at full load. Thus a 3% reactor will drop 3% of the applied voltage at full rated current. To calculate the actual inductance value we would use the following formula.  $L = X_L / (2\pi FL)$  Where L is inductance in Henrys,  $X_L$  is inductive reactance or impedance in Ohms and F is the frequency. In general Frequency will be the line frequency for both input and output reactors.

Your drive distributor should be able to help you size a reactor for use with a drive. If you wish to calculate the value yourself, the following example may be helpful. If a 3% reactor was required for a 100 amp 480 volt drive, a 100 amp or larger current rating would be required. The drive impedance would be:  $Z = V/I$  or  $480/100 = 4.8$  ohms.  $3\% \times 4.8$  ohms = 0.144 ohms inserting this 0.144 impedance in the equation for inductance we get a value of about 300 Microhenrys.

### **Summary:**

A reactor is not a magic wand or a silver bullet but can prevent certain problems when applied properly. For the most part, a reactor at the input or output is not automatically required. Reactors can be helpful in providing some line buffering or adding impedance especially for drives with no DC link choke. For small drives they may be needed to prevent inrush or provide reduction in current harmonics when many small drives are located at one installation. At the output they should only be used to correct low motor inductance and not as a motor protection device.

Use a reactor:

- ✓ To add Line Impedance.
- ✓ To provide some light buffering against low magnitude line spikes.
- ✓ To reducing Harmonics (When no link choke is present).
- ✓ To compensating for a low inductance motor.
- ✓ Only as part of a filter for reflected wave reduction.