



Single and Special Function Safety Monitoring Relays

Bulletin 440R, 440F, 440N

Page	Safety Relay Modules	Input Devices	Output Devices	Category Number	PL	Stop Category
4	MSR5T	440P limit switch	100S-C safety contactors	2	c	0
6	MSR5T	800F E-stop	100S-C safety contactors	4/3	e/d	0
8	MSR22LM	450L safety light curtains, 2-sensor muting	100S-C safety contactors	4	e	0
10	MSR22LM	440L safety light curtains, 4-sensor muting	100S-C safety contactors	4	e	0
12	MSR22LM	450L safety light curtains, Presence Sensing Device Initiation	700S safety relays	4	e	0
14	MSR55P with MSR127	Back EMF of motor, 800F E-stop	100S-C safety contactors	4	e	0
15	MSR55P with MSR127	Back EMF of motor, E-stops, 440G-LZ guard locking switch	PowerFlex® 525 drive	3	d	0
17	MSR57P	800F E-stop, 440K gate interlock switch, speed monitoring	PowerFlex 525 drive	3	d	1
19	MSR57P	800F E-stop, 440G TLS3 guard locking switch, speed monitoring	PowerFlex 70 drive	3	d	1
21	MSR117T	440P limit switch	100S-C safety contactors	3	d	0
22	MSR117T with MSR132E	Ferrogard™ FRS6 switch	700S safety relays	2	c	0
23	MSR124RT	440T Prosafe® rotary switch	100S-C safety contactors	3	d	0
24	MSR124RT	440N SensaGuard™ rectangular flat pack	100S-C safety contactors	4	e	0
25	MSR125HP	800P palm buttons	100S-C safety contactors	4	e	0
26	MSR125HP	800Z Zero-Force Touch Buttons™	100S-C safety contactors	4	e	0
27	MSR126.1R	800F E-stop	100S-C safety contactors	4/3	e/d	0
29	MSR126.1R	440K Trojan™ 5 tongue interlock switches	100S-C safety contactors	3	d	0
31	MSR126T	450L safety light curtain	100S-C safety contactors	4	e	0
32	MSR126.IT	440E Lifeline™ 4 cable pull switch	100S-C safety contactors	3	d	0
33	MSR127RP	800F E-stop	100S-C safety contactors	4	e	0
34	MSR127RP	440N Ferrogard GD2 non-contact switch	100S-C safety contactors	4	e	0
35	MSR127TP	450L safety light curtain	100S-C safety contactors	4	e	0
36	MSR127TP	440N SensaGuard switch with integrated latch	PowerFlex 525 drive	3	d	0
38	MSR131RTP	440L GuardShield™ safety light curtain	100S-C safety contactors	4	e	0
39	MSR131RTP	440K Trojan T15 switch, 800T E-stop	PowerFlex 525 drive	3	d	0
40	MSR138.1DP	440G TLS1-GD2 switch	100S-C safety contactors	3/2	d/d	0
42	MSR138.1DP	442G MAB, 800F E-stop	PowerFlex 525 drive	3	d	1
43	MSR138.1DP	442G MAB (with integral buttons)	PowerFlex 525 drive	3	d	1
44	MSR138.1DP	440G MZ guard locking switch, 800F E-stop	PowerFlex 525 drive	3	d	1
45	MSR138.1DP	440G-LZ switch, 440G-TZ switch, 800F E-stop	100S-C safety contactors	3	d	0
47	MSR142RTP	440K Trojan T15 switch, 800T E-stop	100S-C safety contactors	3	d	0
48	MSR142RTP	450L GuardShield safety light curtain	100S-C safety contactors	4	e	0
49	MatGuard™ controller	Safety mat	100S-C safety contactors	3	d	0
50	MatGuard Manager	Up to 8 safety mats	100S-C safety contactors	3	d	0
52	Safedge™ controller	Safedge profile	100S-C safety contactors	3	d	0
53	Safedge controller	Safedge profile	100S-C safety contactors	2	d	0
54	440N-S Sipa 2 controller	Sipa™ sensors	100S-C safety contactors	4	e	0
56	440N-S Sipa 1 controller	Sipa sensors	100S-C safety contactors	2	d	0

Notes for Example Wiring Diagrams

Note 1

In the wiring diagrams that are shown in this publication, the type of Allen-Bradley® Guardmaster® device is shown as an example to illustrate the circuit principle. For special applications, the choice of device type is based on the suitability of its characteristics for its intended use.

Note 2

In most of the following examples that show dual-channel applications, one interlock switch is shown switching both channels (one contact set per channel). If foreseeable damage (for example, at the actuator mounting point) could allow the guard to be opened without operating the switch, then two separate switches are required. The electrical principle of the circuit remains the same.

Note 3

In most cases, the circuits are shown with the guard door closed and ready for motor starting by operating the normal start control.

It must be possible to start the machine only by voluntary actuation of the control that is provided for the purpose (see ISO 12100-2 4.11.8). For the purposes of these examples, the use of a conventional contactor-latching circuit has been assumed. If not, then a restart interlock is required to help prevent an automatic or unintended starting of the motor when the guard is closed. For example, a Minotaur™ safety relay with a momentary action push button that is installed in the output to monitor the circuit can be used to achieve this protection.

If the guard is designated as a Control Guard (see ISO 12100-2 5.3.2.5), these requirements do not apply. However, the use of control guards is allowed only under certain conditions including:

- A control guard can be used only where there is no possibility of an operator or part of their body staying in or reaching into the danger zone while the guard is closed.
- The control guard must be the only access to the hazardous area.
- The interlocking system must have the highest possible reliability. It is often advisable to use a solenoid locking switch such as the Guardmaster 440G-LZ or TLS-ZR guard locking switches.

Note 4

Safety monitoring relays are used in dual-channel circuits with infrequent operation or with multiple switching devices connected. This note applies to all monitoring devices that compare the signal at the change of state of dual channels.

Certain faults are only detected at a change of state of the input switching device (interlock switch or E-stop switch). If there are long periods (for example, months as opposed to days) between switching actions, it is possible for multiple faults to accumulate, which could lead to a dangerous situation. Therefore, a regular check must be performed on the system to detect single faults before an accumulation occurs. This check can be manual or initiated by part of the control system.

For example, if three interlock switches are connected to the monitoring unit, certain faults are detected only at the switch on the first-opened guard and the switch on the last-closed guard. Faults are only detected at these times because any switching between the first opening and last closing does not change the state of the monitoring unit input circuits. Therefore, in some applications it is necessary to use one monitoring device per switch.

Most of the examples in this publication show an interlock switch and an emergency stop switch that are combined in the circuit. When a monitoring safety relay (for example, a GSR module) is used for fault detection, it is important to note the following:

- All safety-critical single faults, except for certain faults over the contact set at the E-stop, are detected at the next opening of the guard.
- All safety-critical single faults, except for certain faults over the contact set at the interlock switch, are detected at the next operation of the E-stop.
- Because the E-stop device is operated infrequently, we recommend that you check its function (with the guard closed) regularly, at the start of your shift or daily, to enable the safety monitoring relay to detect single faults. If the guard is rarely opened, the interlock switch must be checked in a similar manner.

Note 5



This symbol indicates that the associated component or device features direct opening (positive opening) operation. In the event of a fault, welded contacts are forced open by the motion of the safety guard or E-stop device.



These two symbols denote mechanically linked contacts of safety contactors and safety control relays; if one contact welds closed, all other dependent (auxiliary) contacts remain in position (that is, they cannot change state).

General Safety Information

IMPORTANT

The examples in this section are for advanced users and assumes that you are trained and experienced in safety system requirements. Contact your local Rockwell Automation sales office or Allen-Bradley distributor for more information about our safety risk assessment services.



ATTENTION: Perform a risk assessment to make sure that all tasks and hazard combinations are identified and addressed. The risk assessment requires additional circuitry to reduce the risk to a tolerable level. Safety distance calculations are an important consideration in safety circuits but are not part of the scope of this document.

MSR5T with Safety Limit Switch

Circuit Components

- 440P safety limit switch
- 800F push buttons and pilot lights
- 440R MSR5T safety monitoring relay
- 100S safety contactors

Circuit Description

The MSR5T safety relay monitors the position of a safety gate with a 440P safety limit switch, which has mechanically-operated contacts. The safety limit switch has direct opening, normally closed, contacts that are designed to open forcibly when the gate is opened.

The MSR5T also monitors the status of the three output safety control relays through the X1-X2 circuit. If any of the three control relays becomes stuck in the energized position, the associated N.C. contact remains open, and the MSR5T cannot re-energize the output safety control relays.

A red pilot light connected to the normally open contact (terminals 33/34) of the limit switch indicates that the door is opened or is waiting for reset.

Circuit Status

The gate is closed. The MSR5T outputs are OFF. The MSR5T is waiting for the Reset button to be pushed. The motors are OFF.

Operating Principle

STARTING: With the gate closed, press the Reset button to turn ON the MSR5T safety outputs. The motors are enabled. Press the Start button to start the motors.

STOPPING: Press the Stop button to accomplish a normal production stop. You can also open the gate to initiate a safety stop. In either case, the motor coasts to a stop.

Ratings

Since the limit switch uses one contact and the motors are powered from single-safety control relays, the safety rating is limited to a Category 2 structure that can be used in systems that require Performance Levels up to PLc per ISO 13849-1. The circuit executes a Stop Category 0 per IEC 60204-1 and NFPA79.

Figure 1 - MSR5T with Limit Switch

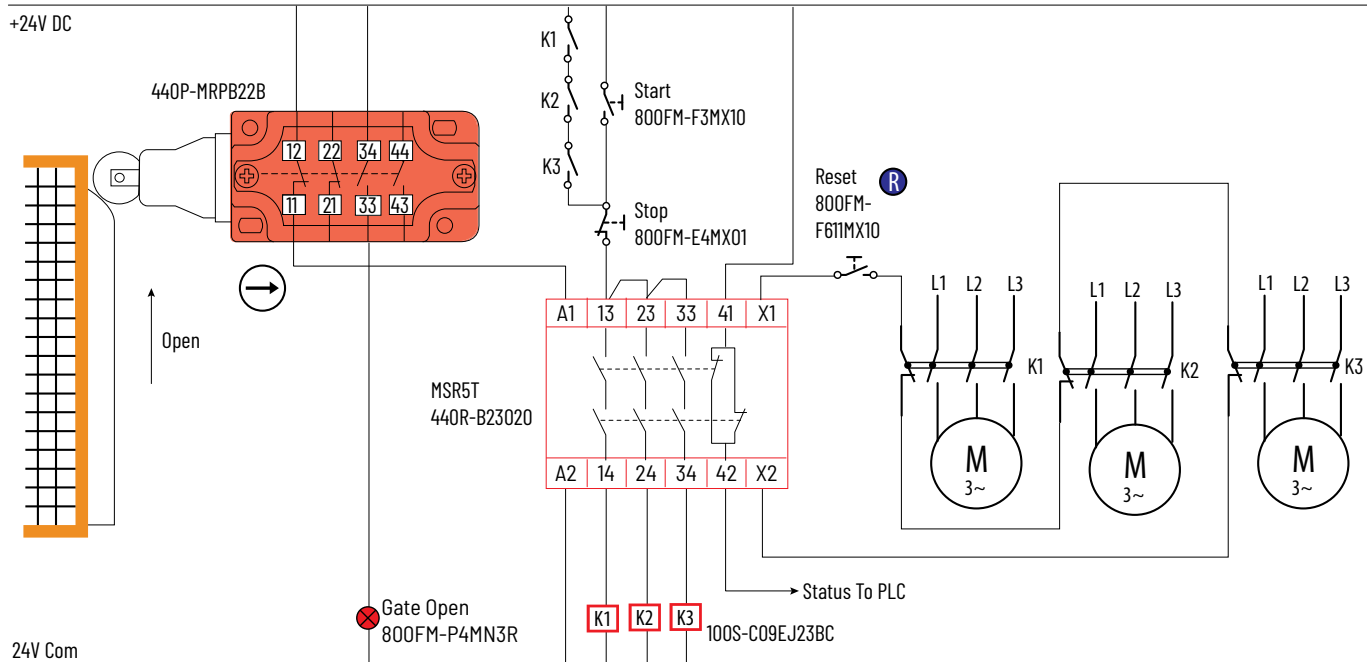

MSR5T with E-stop

Circuit Components

- 800F E-stop, push button, and pilot lights
- 440R MSR5T safety monitoring relay
- 100S safety contactors

Circuit Description

The MSR5T monitors two direct-opening contacts of an E-stop; one contact switches power to the positive side and one contact switches power ON the negative side. When the E-stop is pressed, the MSR5T de-energizes the contactors K1 and K2. The MSR5T also monitors the mechanically linked contacts of the safety contactors K1 and K2.

Circuit Status

The E-stop is released; the MSR5T outputs are OFF; the motor is not spinning, and the MSR5T is waiting for the Reset button to be pressed.

Operating Principle

STARTING: With the E-stop released, press the Reset button. If both contactors are OFF and their N.C. contacts are closed, the MSR5T outputs close, which energizes K1 and K2. Press the Start button to turn the motor ON.

STOPPING: Press the Stop button to stop the motor for production stops. Press the E-stop to initiate a safety stop. In either case, the motor coasts to a stop.

Ratings

In [Figure 2](#), the E-stop initiates a safety function that has a Cat. 4 structure that can be used in systems that require Performance Levels up to PLe per ISO 13849-1, provided a maximum number of operations is considered for the E-stop per ISO 13849-2. The circuit executes a Stop Category 0 per IEC 60204-1 and NFPA79.

In [Figure 3 on page 7](#), the series connection of the E-stops reduces the circuit structure to Cat. 3 and Performance Level to d per ISO 13849-1.

Figure 2 - MSR5T with E-stop

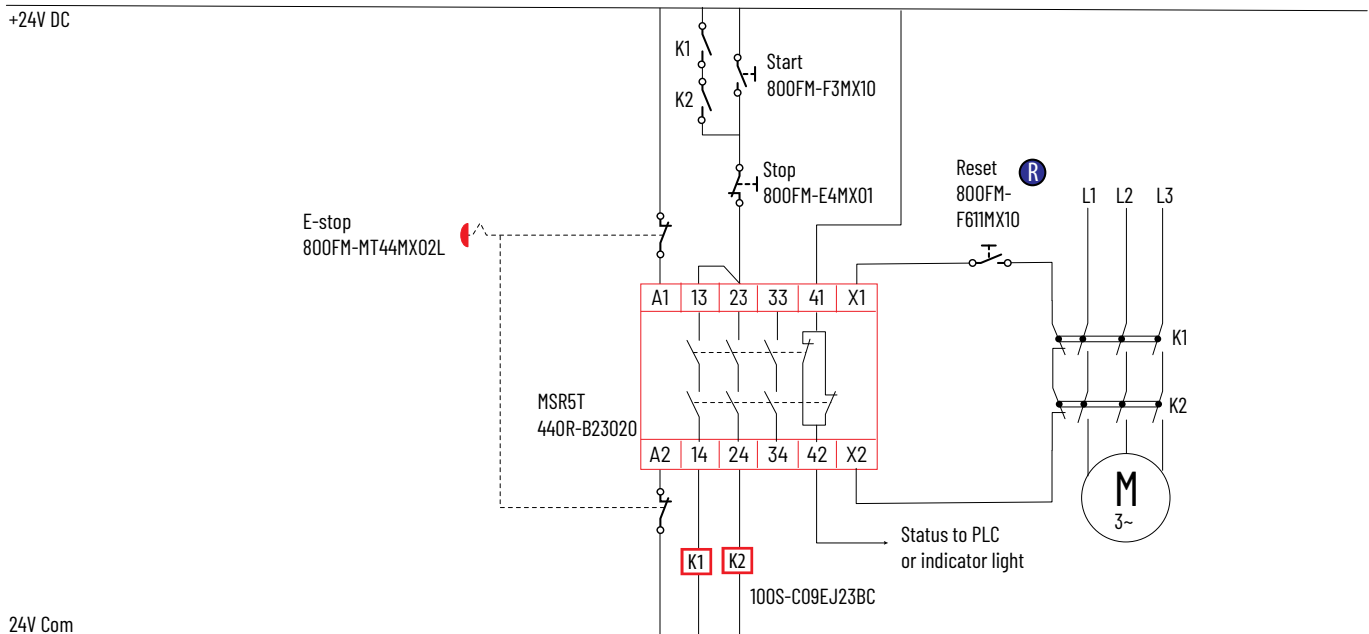
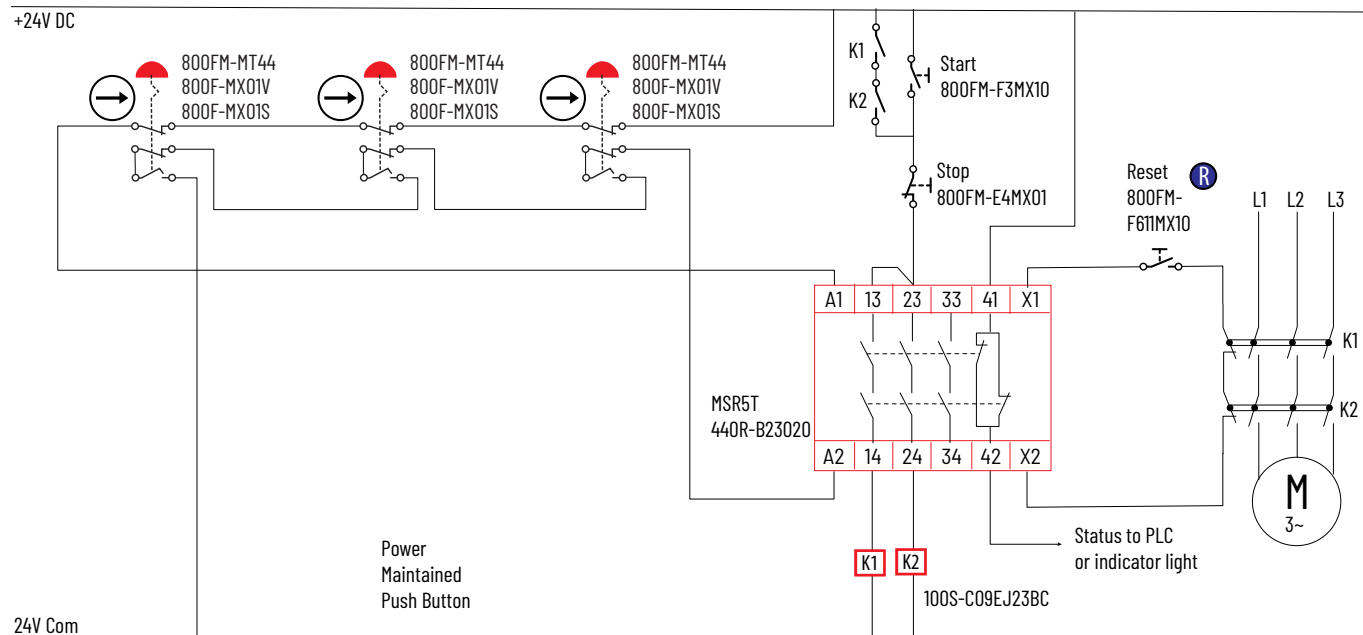

Figure 3 - MSR5T Safety Relay with Series Connection of E-stops



MSR22LM 2-sensor Muting of Safety Light Curtain

Circuit Components

- 450L safety light curtains
- 800F push buttons and indicator
- 440R MSR22LM safety muting relay
- 100S safety contactors

Circuit Description

This example has two safety light curtains. One safety light curtain (LC1) can be muted by the two muting sensors. The second safety light curtain (LC2) operates in Guard Only mode. A momentary key-operated switch turns ON the motor if the object being transported gets stuck in the safety light curtain.

The following image shows the arrangement of the muting sensors: an offset X arrangement. The material must break MS1, then MS2, then LC1, clear LC1, clear MS2, and finally clear MS1 within the configured time.

Figure 4 - 2-sensor Muting with Offset X Arrangement

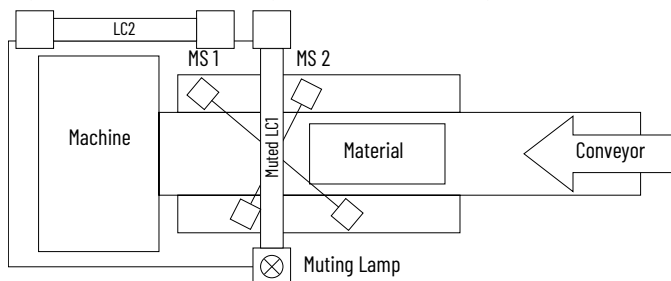

Circuit Status

Both safety light curtains and both muting sensors are clear. The motor (conveyor) is OFF. The MSR22LM outputs are OFF and ready to start.

Operating Principle

STARTING: With both safety light curtains and muting sensors clear, and the muting lamp working, press the Start/Restart button to energize MSR22LM outputs. Press the Start button to turn the motor ON.

STOPPING: Typical production stoppage is by using the Stop button. A stop also occurs if the muting sequence is violated or if the safety light curtain (LC2) is interrupted.

Ratings

The safety function has a structure that meets Category 4 and can be used in systems that require Performance Levels up to PLe per ISO 13849-1. This circuit executes a Stop Category 0 per IEC 60204-1 and NFPA79.

Figure 5 - One Muted Safety Light Curtain, Second Safety Light Curtain Guard Only

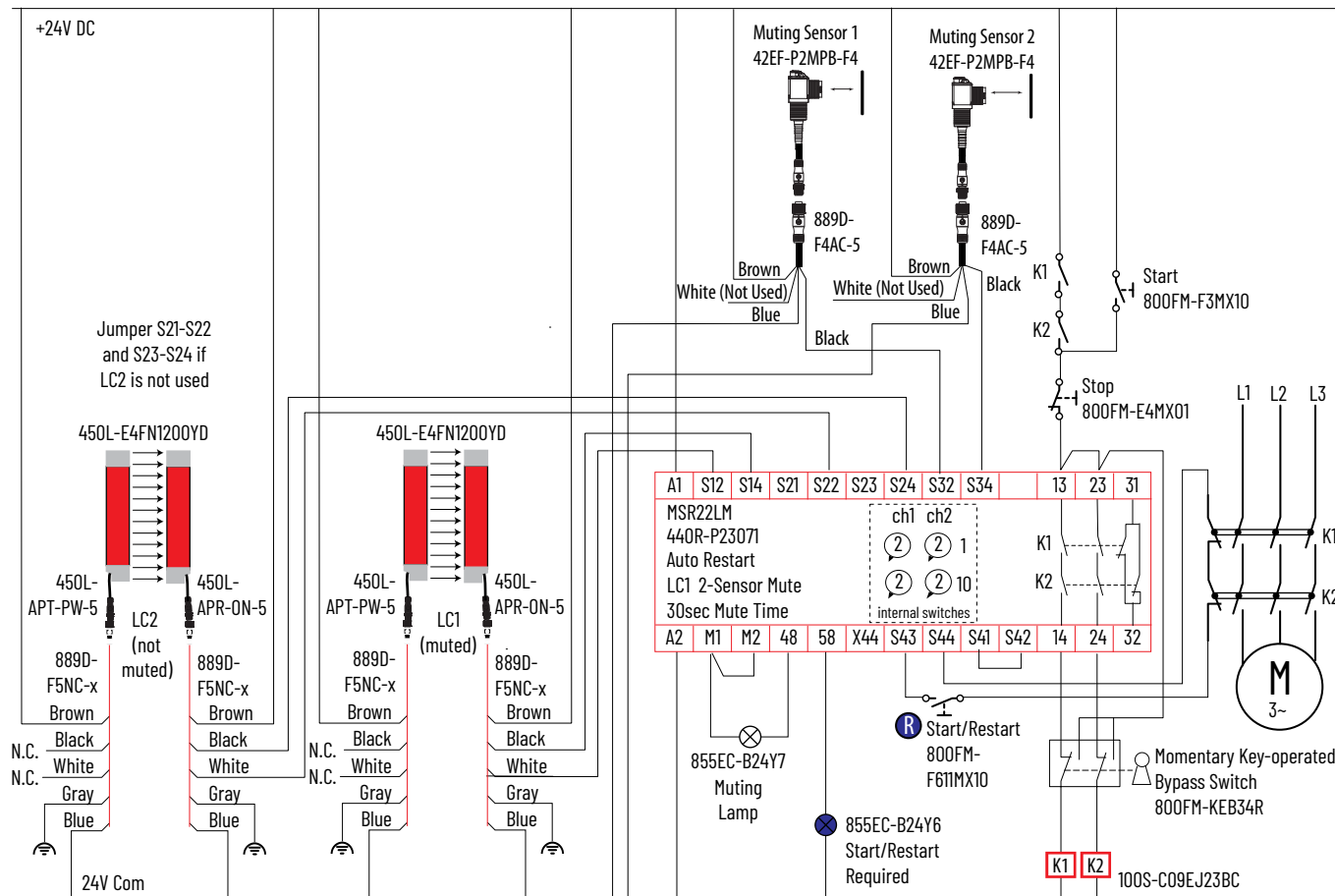

MSR22LM 4-sensor Muting of Safety Light Curtain

Circuit Components

- 440L GuardShield safety light curtain
- 42EF photoelectric sensors
- 800F push buttons and indicator lights
- 440R MSR22LM safety muting relay
- 100S safety contactors

Circuit Status

This example has one safety light curtain, muted by four photoelectric sensors. A momentary key-operated switch turns ON the motor if the object being transported gets stuck in the muting station.

The following image shows the arrangement of the muting sensors: the material must break the sensors and safety light curtain in sequence.

Figure 6 - 4-sensor Muting Arrangement

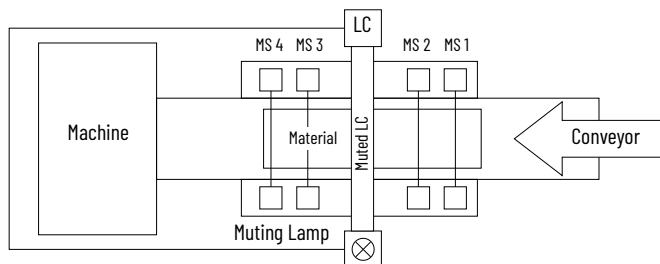

Circuit Status

The safety light curtain and all four muting sensors are clear. The motor (conveyor) is OFF. The MSR22LM outputs are OFF and ready to start.

Operating Principle

STARTING: With the safety light curtain and muting sensors clear, and the muting lamp working, press the Start/Restart button to energize MSR22LM outputs. Press the Start button to turn the motor ON.

STOPPING: Typical production stoppage is by using the Stop button. A stop also occurs if the muting sequence is violated.

Ratings

The safety function has a structure that meets Category 4 and can be used in systems that require Performance Levels up to PLe per ISO 13849-1. This circuit executes a Stop Category 0 per IEC 60204-1 and NFPA79.

Figure 7 - MSR22LM – 4-sensor Muting of Safety Light Curtain

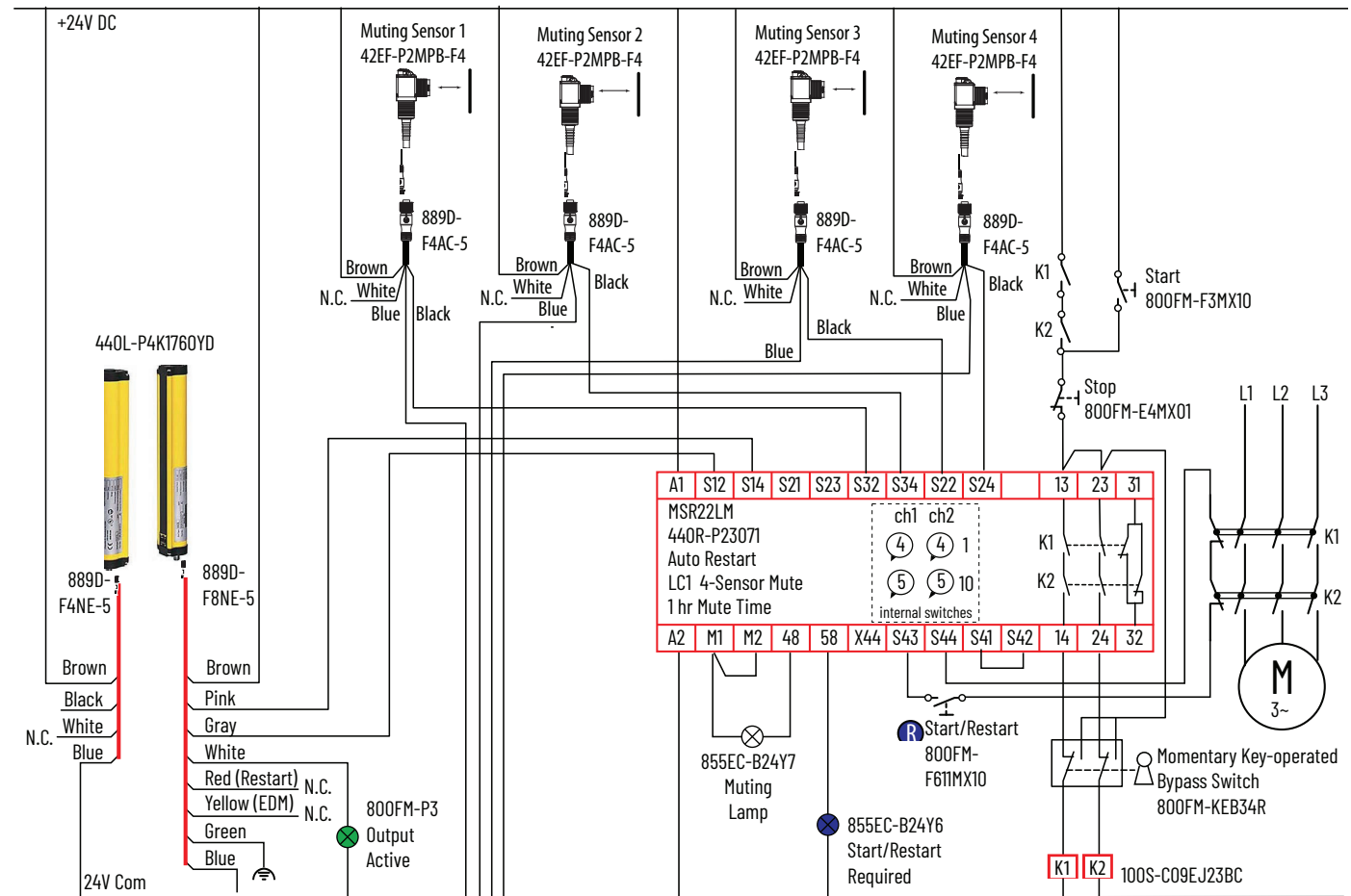

MSR22LM Presence Sensing Device Initiation (PSDI)

Circuit Components

- 450L safety light curtains
- 800F push buttons
- 440R MSR22LM safety muting relay
- 100S safety contactors

Circuit Description

Presence sensing device initiation (PSDI) allows the machine to restart automatically when the pre-configured make/break sequence of a safety light curtain is performed properly; no need to press an additional button to restart the machine cycle. This example has three safety light curtains. Two safety light curtains operate in Guard Only mode; one safety light curtain is used for PSDI.

This example is a double break:

1. When the machine has completed its cycle, the operator reaches through the safety light curtain to retrieve a part.
and
2. Operator reaches in to place a new part. When the operator clears the safety light curtain, the machine automatically restarts.

Circuit Status

The three safety light curtains sensors are clear. The motor (conveyor) is OFF. The MSR22LM outputs are OFF and ready to start.

Operating Principle

PSDI is a specific operational sequence that is convenient when access to place and remove parts happens often.

Ratings

The safety function has a structure that meets Category 4 and can be used in systems that require Performance Levels up to PLe per ISO 13849-1. This circuit executes a Stop Category 0 per IEC 60204-1 and NFPA79.

Figure 8 - MSR22LM - Presence Sensing Device Initiation (PSDI)

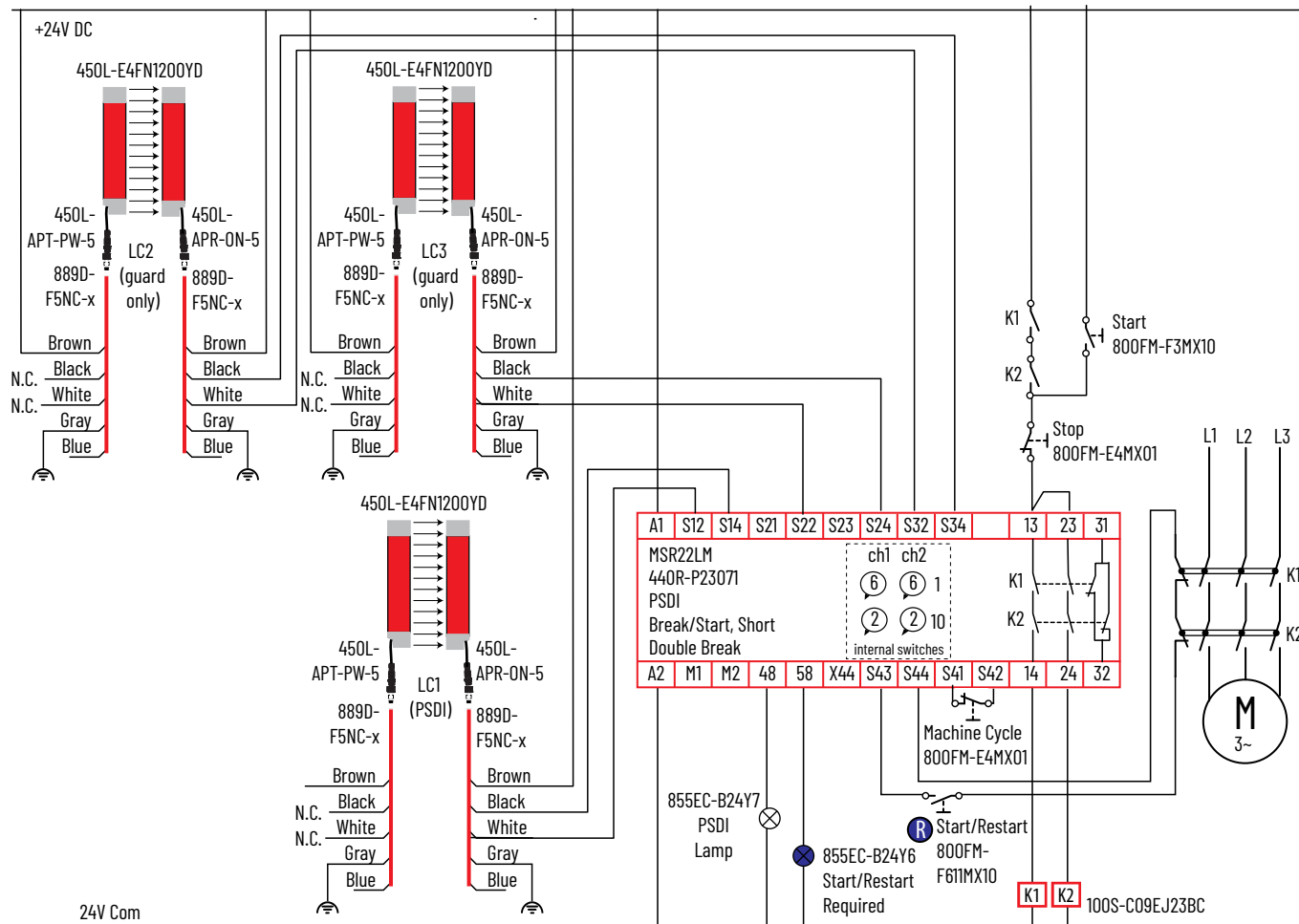

MSR55P Back EMF Safety Relay with MSR127 Safety Relay with E-stop

Circuit Components

- 800F E-stop and push button
- 440R MSR55P back EMF safety relay
- 440R MSR127 safety relay
- 100S contactors

Circuit Description

The MSR55P safety relay monitors the back EMF of a motor that the dual 100S contactors operate. An E-stop initiates a command to stop the motor. A PLC controls turns the motor ON and OFF when the safety system is satisfied. The PLC monitors the status of both the MSR127 and MSR55P safety relays. When the back EMF drops below the configured threshold, the MSR55P safety relay provides power to safety devices. The MSR127 safety relay monitors the operation of the contactors and the MSR55P safety relay.

Circuit Status

The E-stop is released. The MSR127 outputs are OFF and the motor is OFF.

Operating Principle

STARTING: Press the Reset button to energize the MSR127 outputs. Press the Start button to energize the 100S contactors, which turns ON the motor.

STOPPING: Press the Stop button for a normal production stop. Press the E-stop for an emergency or a safety-related stop.

Ratings

With only one E-stop monitored by the MSR127 safety relay, the safety function that the E-stop initiates has a Category 4 structure that can be used in systems that require Performance Levels up to PLe per ISO 13849-1. The MSR55P safety relay has a Category 4 structure that can be used in systems that require Performance Levels up to PLe per ISO 13849-1. The rating of the safety function of the safety devices that are controlled by the MSR55P safety relay is dependent on how those devices are connected and used. This circuit executes a Stop Category 0 per IEC 60204-1 and NFPA79.

Figure 9 - MSR55P Safety Relay and MSR127 Safety Relay with E-stop

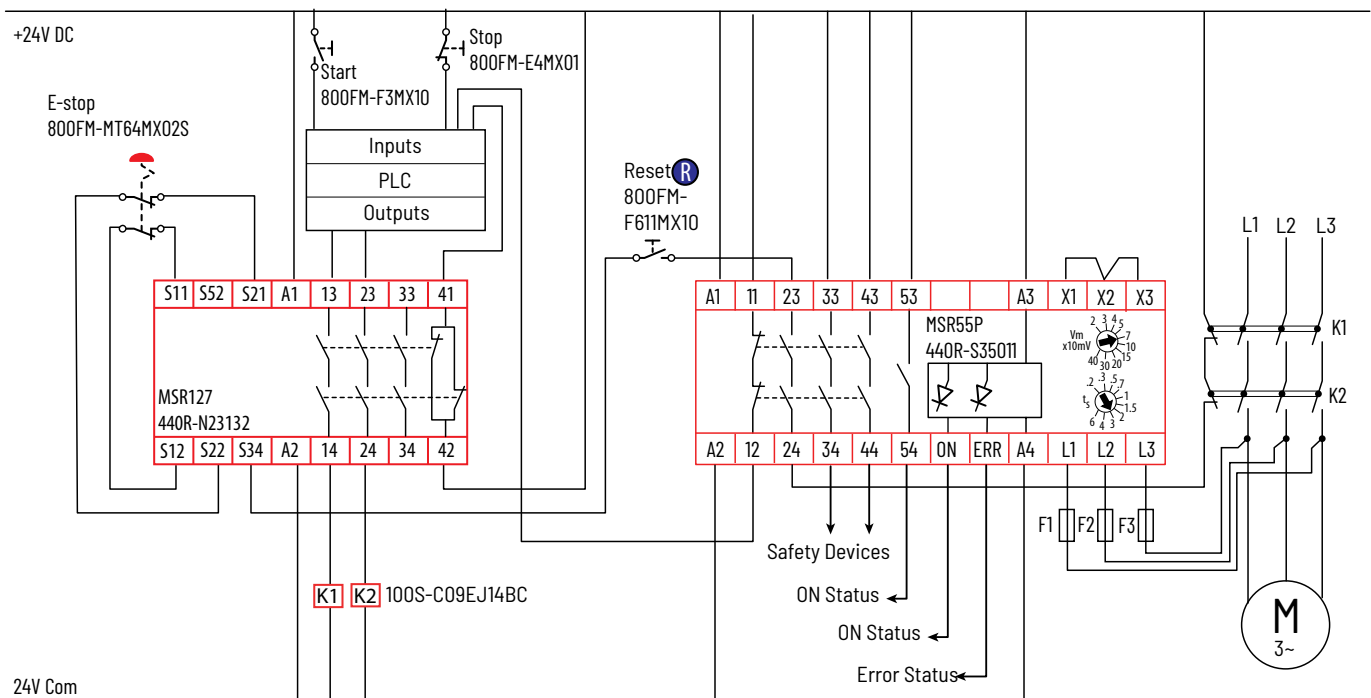

MSR55P Back EMF Safety Relay with MSR127 Safety Relay with Guard Locking and E-stop

Circuit Components

- 800F E-stop, push button, and pilot lights
- 440G-LZ Power to Release guard locking switch
- 440R MSR55P back EMF safety relay
- 440R MSR127 safety relay
- 25A PowerFlex 525 drive

Circuit Description

The MSR55P safety relay monitors the back EMF of a motor that the PowerFlex 525 drive operates. When the motor speed drops below the configured threshold, the MSR55P safety relay enables an unlock command to the 440G-LZ switch. A two-position selector switch unlocks/locks the 440G-LZ. The MSR127 safety relay monitors an E-stop connected in series with the outputs of the 440G-LZ switch. If the gate is unlocked or if the E-stop is pressed, the MSR127 safety relay sends an immediate safety stop command to the PowerFlex 525 drive.

Circuit Status

The E-stop is released, and the gate is closed and locked. The motor is OFF. The MSR127 safety relay is waiting for the reset signal.

Operating Principle

STARTING: Press the Reset button. The MSR127 contacts close and enable the PowerFlex 525 drive to start. Press the Start button to turn ON the motor and accomplish a normal production start.

STOPPING: Press the Stop button to accomplish a normal production stop. The PowerFlex 525 drive executes its pre-configured stop sequence. When the back EMF of the motor stops that gate can be unlocked.

Ratings

The safety function that the E-stop and 440G-LZ switch initiate has a Category 3 structures that can be used in systems that require Performance Levels up to PLd per ISO 13849-1. This circuit executes a Stop Category 0 per IEC 60204-1 and NFPA79.

Figure 10 - MSR55P Safety Relay with Guard Locking

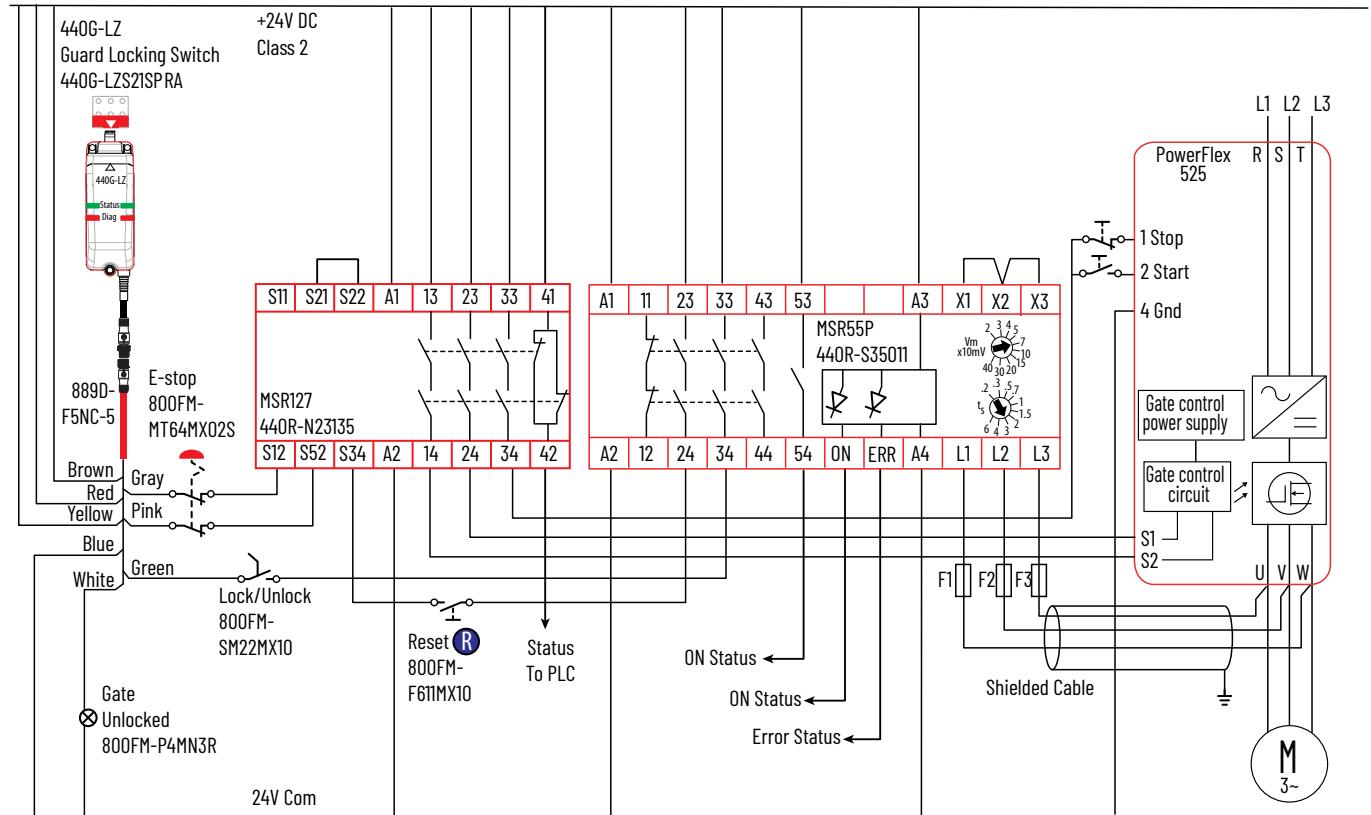

MSR57P Speed Monitoring with E-stop and Gate Interlock

Circuit Components

- 800F E-stop and push buttons
- 440K gate interlock
- 440R MSR57 speed monitoring safety relay
- 25B PowerFlex 525 drive

Circuit Description

The MSR57 monitors an E-stop, a gate interlock, and a Safely-limited Speed (SLS) selector switch. The MSR57 uses an encoder (not shown) to detect the motor speed and direction.

Circuit Status

The E-stop is released. The gate is closed. The SLS switch is closed to allow for full motor speed.

Operating Principle

STARTING: Press the Reset button to apply power to the Stop and Start buttons and the safe torque inputs (S1 and S2). Press the Start button to start the motor.

STOPPING: Press the Stop button to accomplish a normal production stop. Opening the gate or pressing the E-stop causes the motor to stop.

SAFELY-LIMITED SPEED: Set the SLS switch to limited speed to instruct the PowerFlex 525 drive to operate the motor at a Safely-limited Speed. To return to normal running speed, set the SLS switch back to normal and press the Reset button.

Ratings

The safety functions have a Category 3 structure that can be used in systems that require Performance Levels up to PLd per ISO 13849-1. This circuit executes a Stop Category 1 per IEC 60204-1 and NFPA79.

Figure 11 - MSR57 with E-stop and Gate Interlock

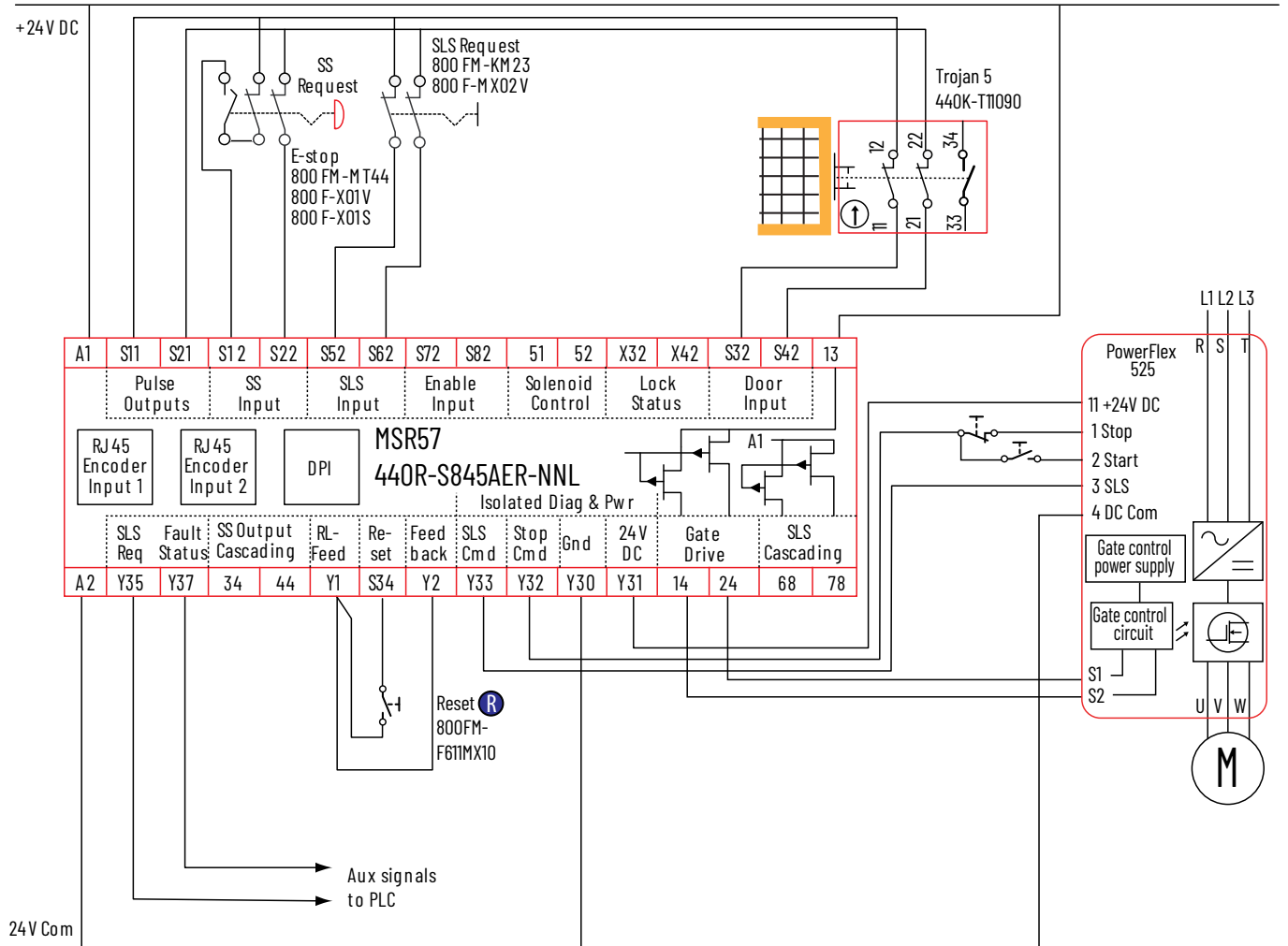

MSR57P Speed Monitoring with E-stop and Guard Locking

Circuit Components

- 800F E-stop push button
- 440G TLS3-GD2 guard locking gate interlock
- 440J enabling switch
- 440R MSR57 speed monitoring safety relay
- 20A PowerFlex 70 AC drive

Circuit Description

The MSR57 monitors an E-stop, a gate interlock, and a Safely-limited Speed (SLS) selector switch. The MSR57 uses an encoder (not shown) to detect the motor speed and direction.

Circuit Status

The E-stop is released. The gate is closed. The SLS switch is closed to allow for full motor speed.

Operating Principle

STARTING: Press the Reset button to apply power to the Stop and Start buttons and the safe torque inputs (S1 and S2). Press the Start button to start the motor.

STOPPING: Press the Stop button to accomplish a normal production stop. Opening the gate or pressing the E-stop causes the motor to stop.

SAFELY-LIMITED SPEED: Set the SLS switch to limited speed to instruct the PF70 to operate the motor at a Safely-limited Speed. To return to normal running speed, set the SLS switch back to normal and press the Reset button.

Ratings

The safety functions have a Category 3 structure that can be used in systems that require Performance Levels up to PLd per ISO 13849-1. This circuit executes a Stop Category 1 per IEC 60204-1 and NFPA79.

Figure 12 - MSR57 with E-stop and Guard Locking Interlock

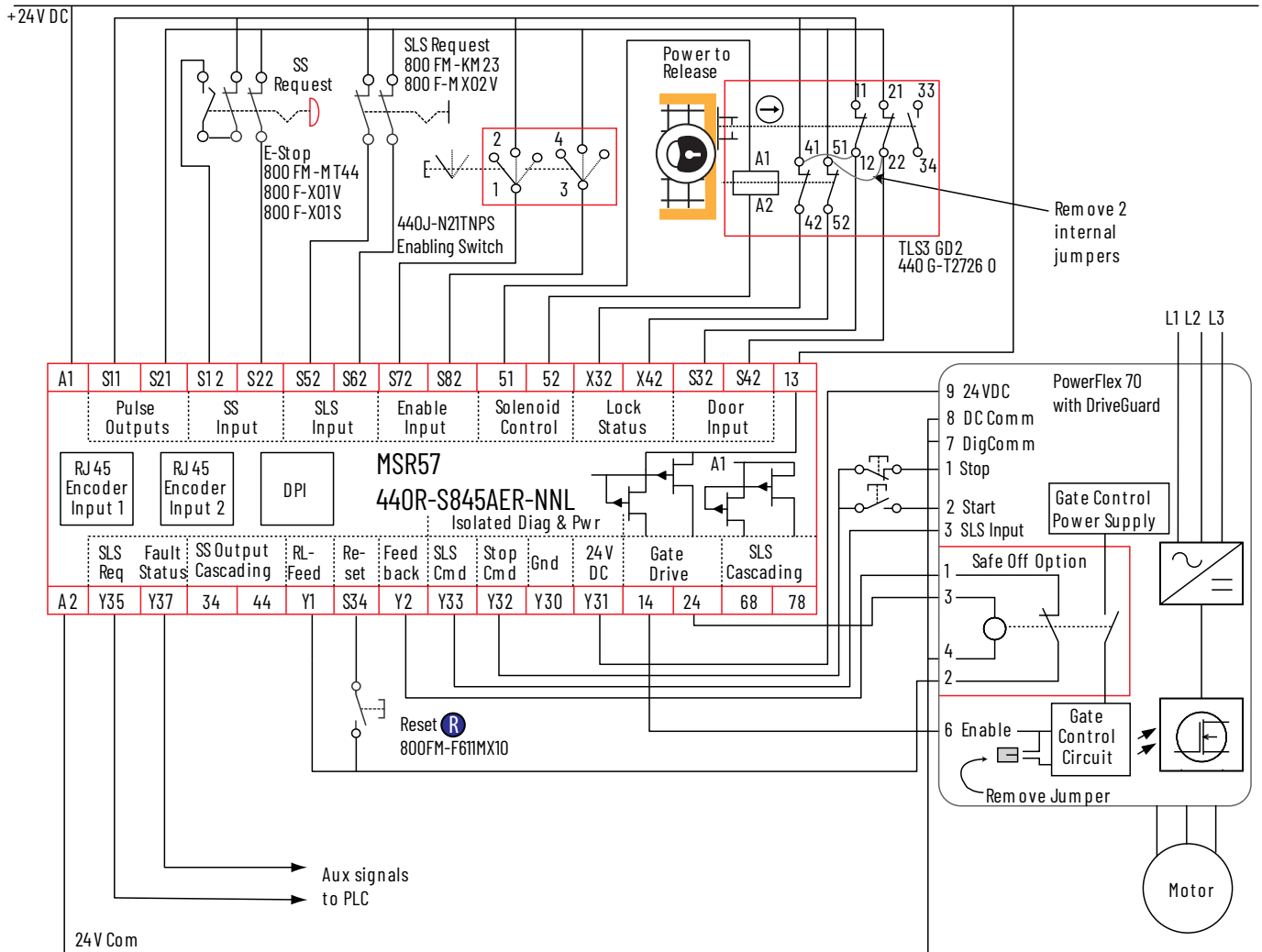

MSR117T Safety Relay with Safety Limit Switch

Circuit Components

- 440P safety limit switch
- 440R MSR117 safety monitoring relay, with automatic reset
- 100S safety contactors

Circuit Description

The MSR117 monitors the position of a safety gate through a 440P safety limit switch. With the gate closed, the external switching circuit can turn ON the motor. Opening the gate causes the motor to coast to a stop. While the gate is open, the motor cannot restart.

Circuit Status

The gate is closed and the motor is OFF. The MSR117T safety relay is waiting for the reset signal.

Operating Principle

STARTING: With the gate closed, use the external switching circuit to turn ON the motor.

STOPPING: The external switching circuit accomplishes a normal production stop. A safety stop occurs when the gate is opened.

Ratings

The 440P limit switches initiate a safety function that has a Category 4 structure that can be used in systems that require Performance Levels up to PLe per ISO 13849-1. The circuit executes a Stop Category 0 per IEC 60204-1 and NFPA79.

Figure 13 - MSR117 Safety Relay with Safety Limit Switch

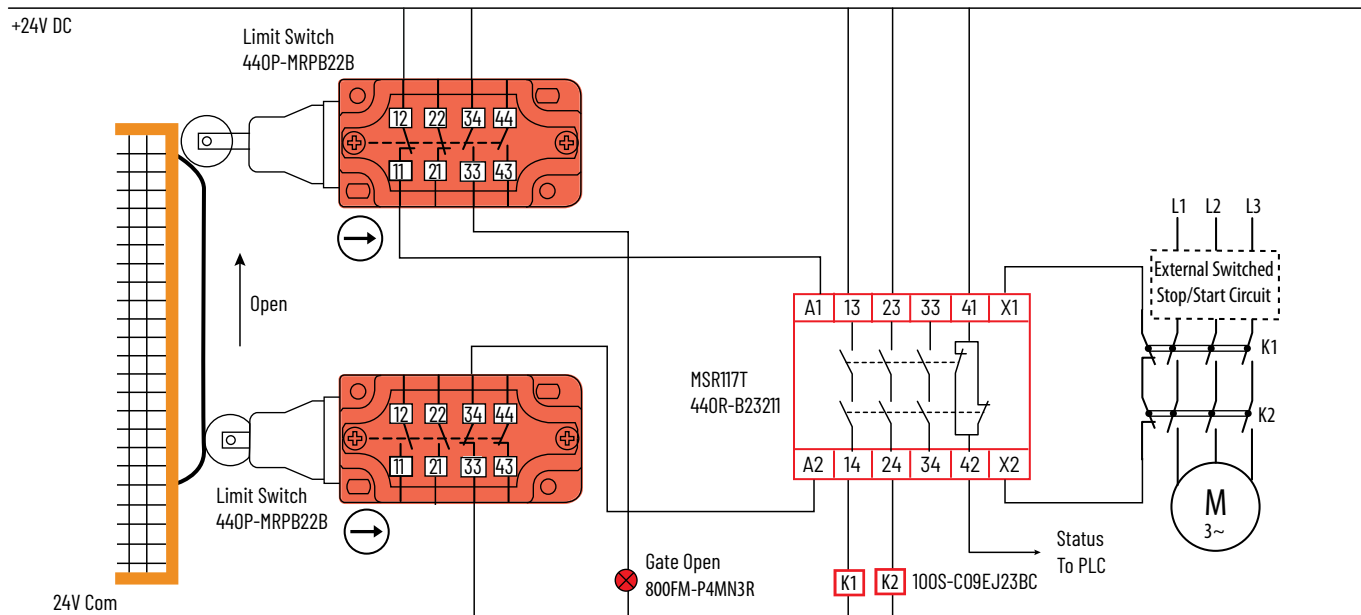

MSR124RT Safety Relay with Prosafe Trapped Keyswitch

Circuit Components

- 440T Prosafe trapped keyswitch
- 440R MSR124RT safety monitoring relay
- 100S safety contactors

Circuit Description

The MSR124 monitors the contacts of the Prosafe rotary switch and also monitors the status of the safety contactors.

Circuit Status

The Prosafe contacts are closed. The MSR124 outputs are OFF; the safety contactors are OFF; and the motors are OFF. The MSR127 safety relay is waiting for the reset signal. The MSR124RT safety relay is waiting for the reset signal.

Operating Principle

STARTING: Press the Reset button to energize the MSR124RT outputs, which energize the 100S contactors. External circuitry must be used to turn ON the motors.

STOPPING: The external circuitry accomplishes a normal production stop. Open the Prosafe rotary switch contacts to execute a safety stop.

Ratings

The Prosafe rotary switch initiates a safety function that has a structure that meets Category 3 and can be used in safety systems that require up to Performance Level PLd per ISO13849-1. The circuit executes a Stop Category 0 per IEC 60204-1 and NFPA79.

Figure 15 - MSR124 with Prosafe Trapped Key Rotary Switch

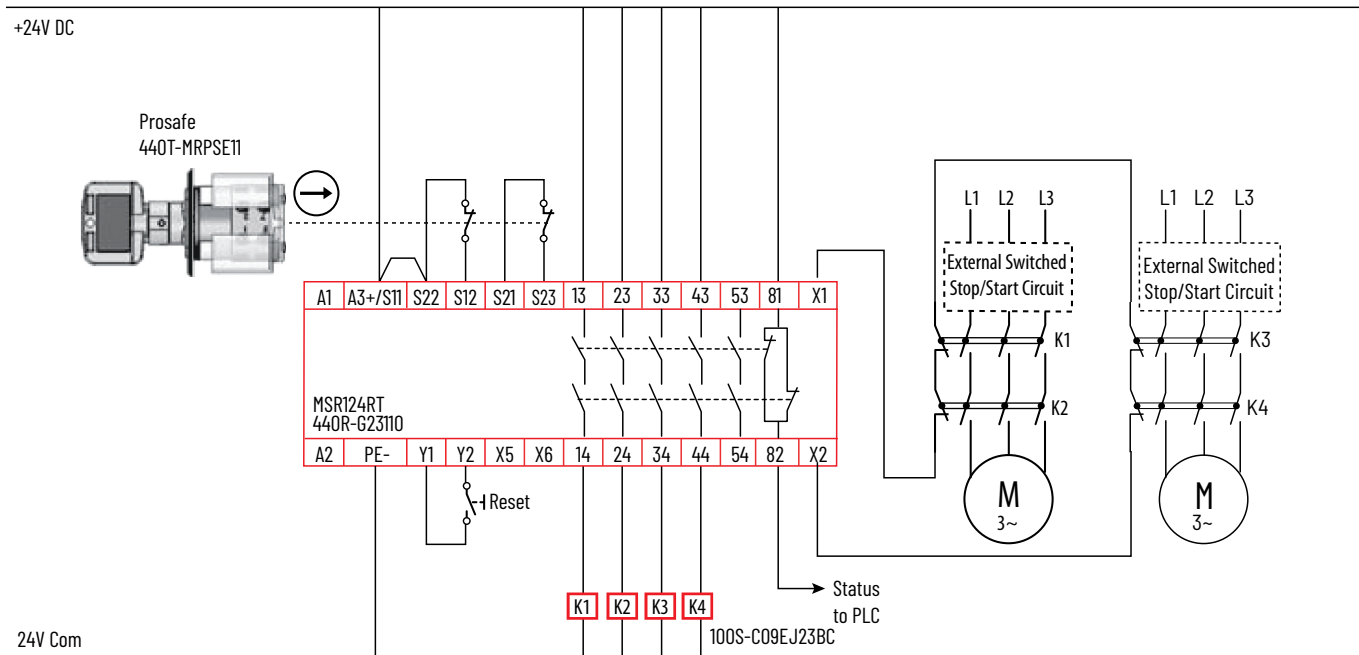

MSR124RT Safety Relay with SensaGuard Rectangular Flat Pack

Circuit Components

- 440N SensaGuard non-contact interlock switch
- 440R MSR124RT safety monitoring relay
- 100S safety contactors

Circuit Description

The MSR124RT safety relay monitors the position of a safety gate through the 440N SensaGuard switch. The MSR124RT safety relay is configured for automatic reset. The MSR124RT safety relay also monitors the status of the 100S safety contactors. The MSR124RT safety relay only energizes its safety outputs if the safety contactors are OFF, and the gate is closed.

Circuit Status

The safety gate is open. The MSR124RT safety outputs are OFF. The safety contactors are OFF, and the motors are OFF.

Operating Principle

STARTING: Close the gate. The MSR124RT outputs close, which energizes contactors K1 through K4 and also sends a signal to the PLC. The PLC can then Start the motors with an external circuit.

STOPPING: The PLC commands to the external circuit accomplish a normal production stop. Opening the gate causes the MSR124RT outputs to turn OFF, dropping out the contactors K1 through K4, and the signal to the PLC. The motors coast to a stop.

Ratings

The SensaGuard interlock switch initiates a safety function that has a structure that meets Category 4 and can be used in safety systems that require up to Performance Level PLe per ISO13849-1. The circuit executes a Stop Category 0 per IEC 60204-1 and NFPA79.

Figure 16 - MSR124 with SensaGuard Rectangular Flat Pack

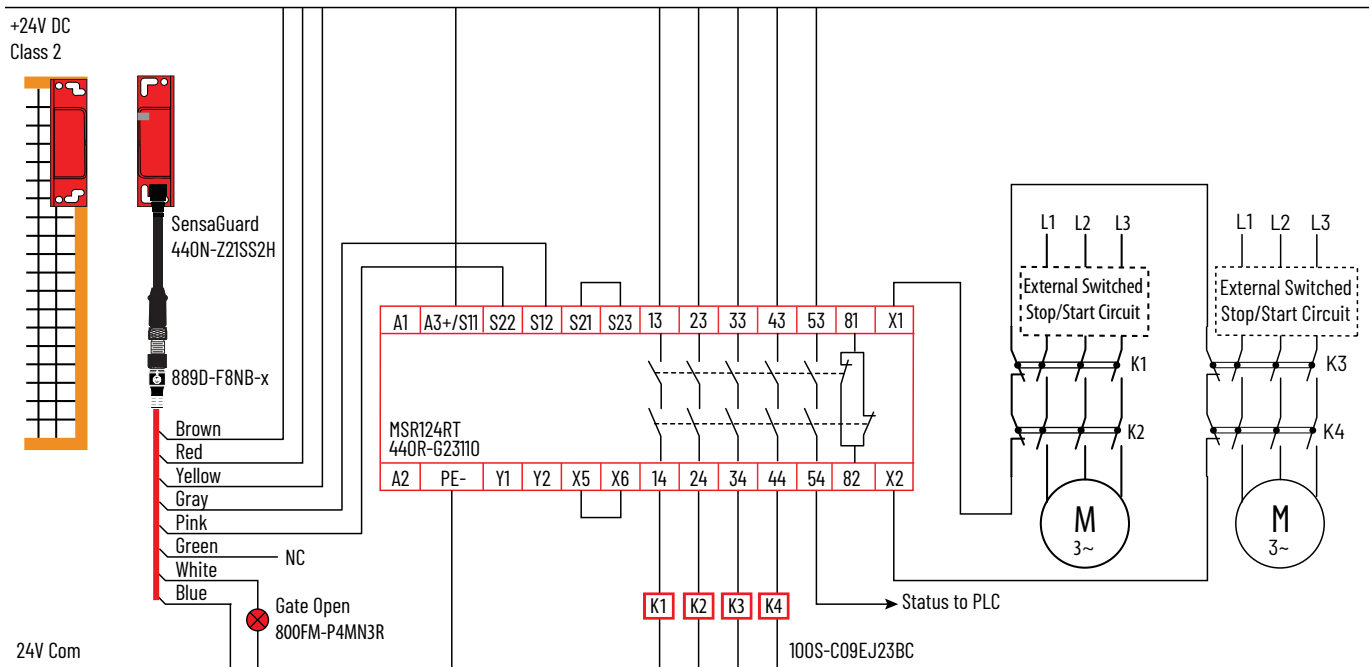

MSR125HP Safety Relay Two-hand Control with 800P Palm Buttons

Circuit Components

- 800P palm buttons
- 440R MSR125HP safety monitoring relay, with automatic reset
- 100S safety contactors

Circuit Description

The MSR125HP safety relay monitors the position of two 800P palm buttons. Both palm buttons must be actuated within 500 ms of each other to energize the MSR125HP outputs.

Circuit Status

The palm buttons are released, and the motor is OFF.

Operating Principle

STARTING: Press both buttons within 500 ms of each other to energize the MSR125HP outputs. The outputs energize the 100S safety contactors, which energize the motor.

STOPPING: Release one or both palm buttons to de-energize the MSR125HP outputs which causes the motor to coast to a stop.

Ratings

The circuit meets the requirements of Type IIIC per ISO 13851 and can be used in circuits up to Category 4, Performance Level PL_e per ISO13849-1. The circuit executes a Stop Category 0 per IEC 60204-1 and NFPA79.

Figure 17 - MSR125HP Safety Relay Two-hand Control with 800P Palm Buttons

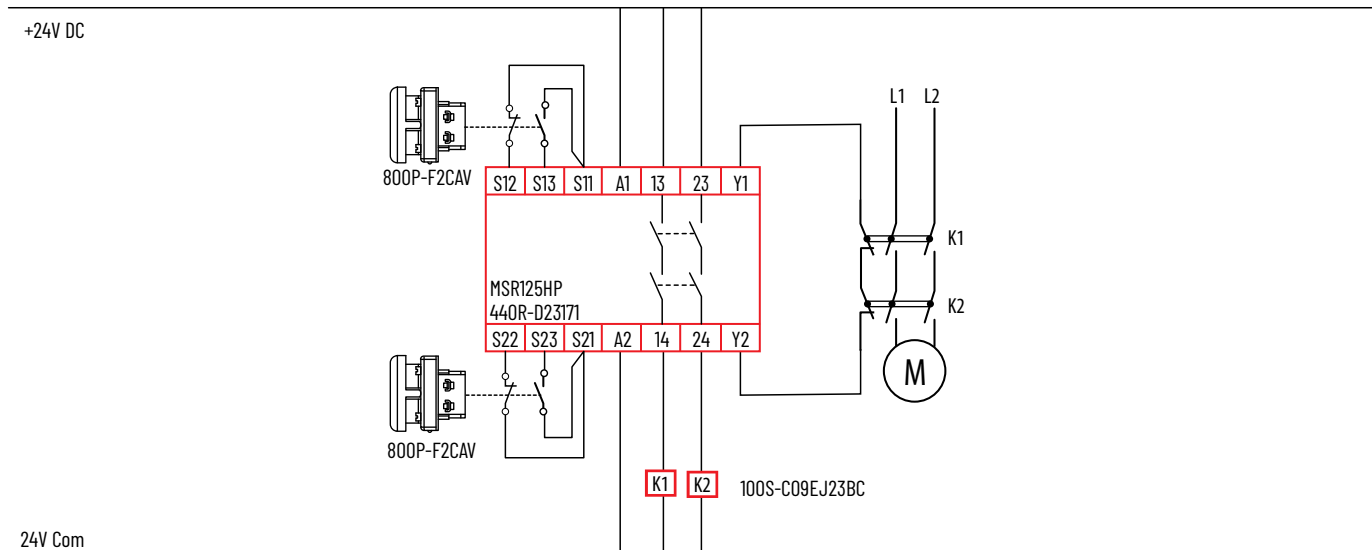

MSR125HP Safety Relay Two-hand Control with 800Z Zero-Force Touch Buttons

Circuit Components

- 800Z Zero-Force Touch Buttons
- 440R MSR125HP safety monitoring relay, with automatic reset
- 100S safety contactors

Circuit Description

The MSR125HP safety relay monitors the position of two 800Z touch buttons. Both touch buttons must be actuated within 500 ms of each other to energize the MSR125HP outputs.

Circuit Status

The touch buttons are released, and the motor is OFF.

Operating Principle

STARTING: Press both buttons within 500 ms of each other to energize the MSR125HP outputs. The outputs energize the 100S safety contactors, which energize the motor.

STOPPING: Release one or both touch buttons to de-energize the MSR125HP outputs which causes the motor to coast to a stop.

Ratings

The circuit meets the requirements of Type IIIC per ISO 13851 and can be used in circuits up to Category 4, Performance Level PL_e per ISO13849-1. The circuit executes a Stop Category 0 per IEC 60204-1 and NFPA79.

Figure 18 - MSR125HP Safety Relay Two-hand Control with 800Z Zero-Force Touch Buttons

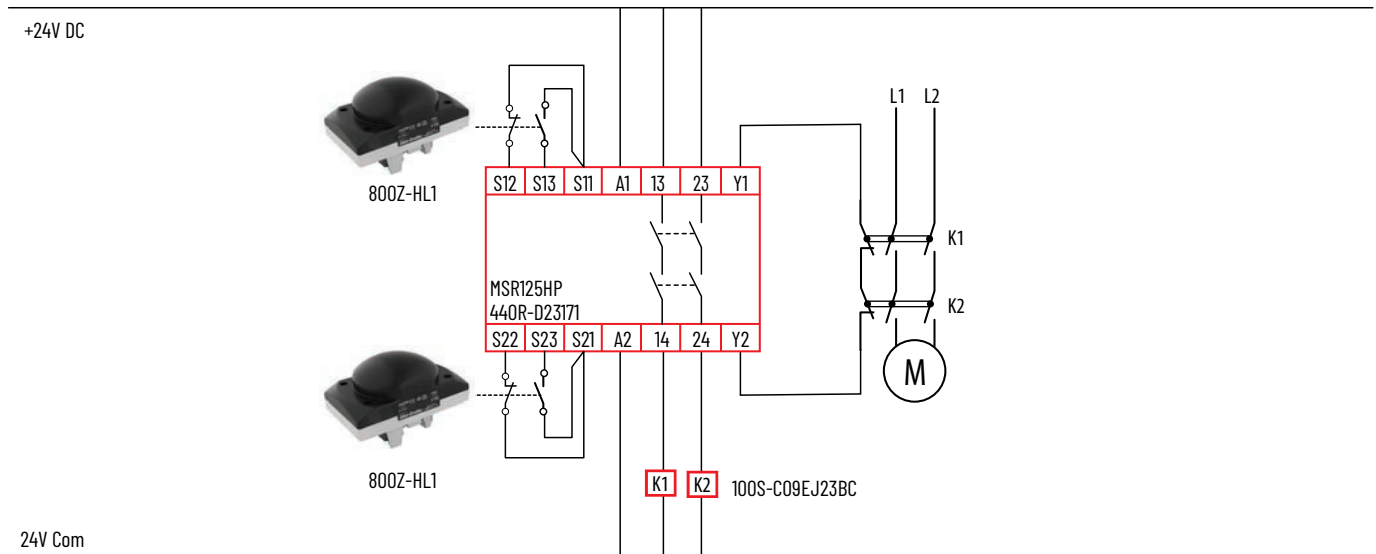

MSR126.1R Safety Relay with 800F E-stop

Circuit Components

- 800F E-stop and push buttons
- 440R MSR126.1R safety monitoring relay, with monitored manual reset
- 100S safety contactors

Circuit Description

The MSR126.1R monitors the position of an 800F E-stop and the status of two 100S safety contactors.

Circuit Status

The E-stop is released. The outputs of the MSR126 are de-energized and ready for reset. The motor is OFF.

Operating Principle

STARTING: Press the Reset button to energize the MSR126 outputs. If the safety control relays are OFF, then the MSR126 outputs energize. Press the Start button to energize the 700S safety control relays, which turn ON the motor.

STOPPING: Press the Stop button to accomplish a normal production stop. You can also press the E-stop to stop the motor.

Ratings

In [Figure 19](#), the E-stop initiates a safety function that has a structure that meets Category 4 and can be used in systems that require Performance Levels up to PLe per ISO 13849-1, provided a maximum number of operations is considered for the E-stop per ISO 13849-2. The circuit executes a Stop Category 0 per IEC 60204-1 and NFPA79.

Figure 19 - MSR126 with Single E-stop

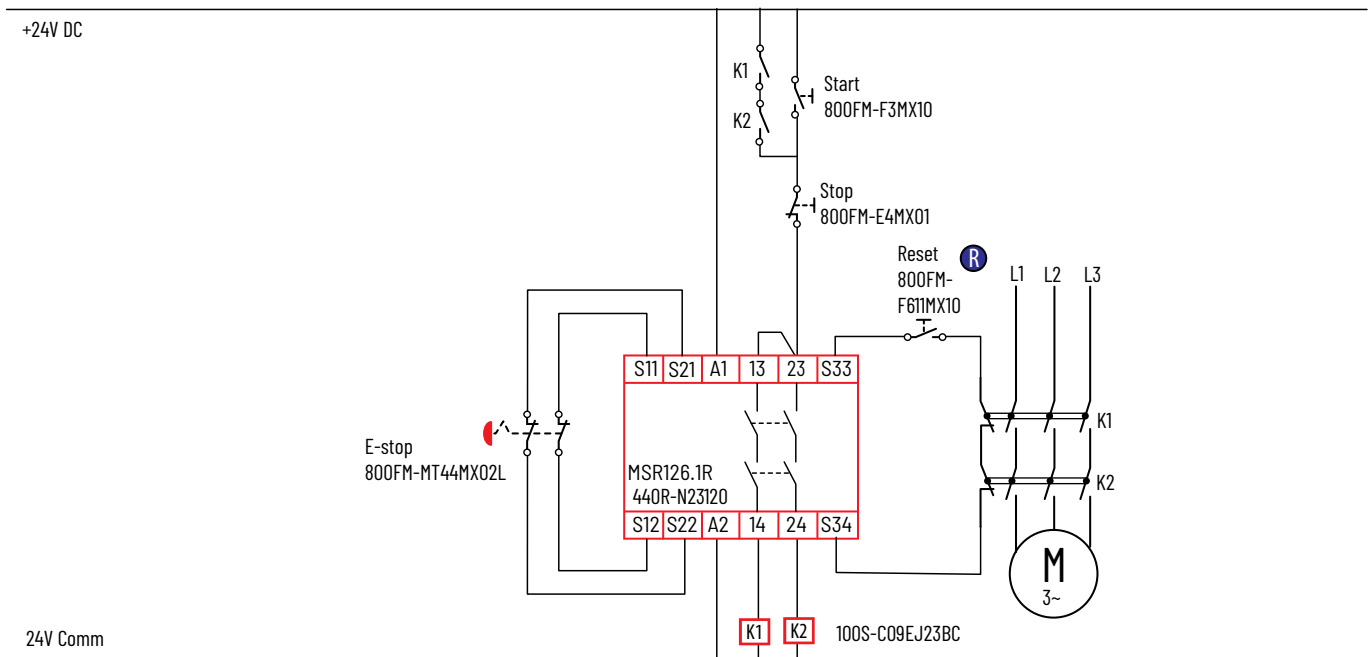

In [Figure 20](#), multiple E-stops are connected in series, which reduces the structure to Category 3, up to PLd.

Figure 20 - MSR126 with Series Connection of E-stops

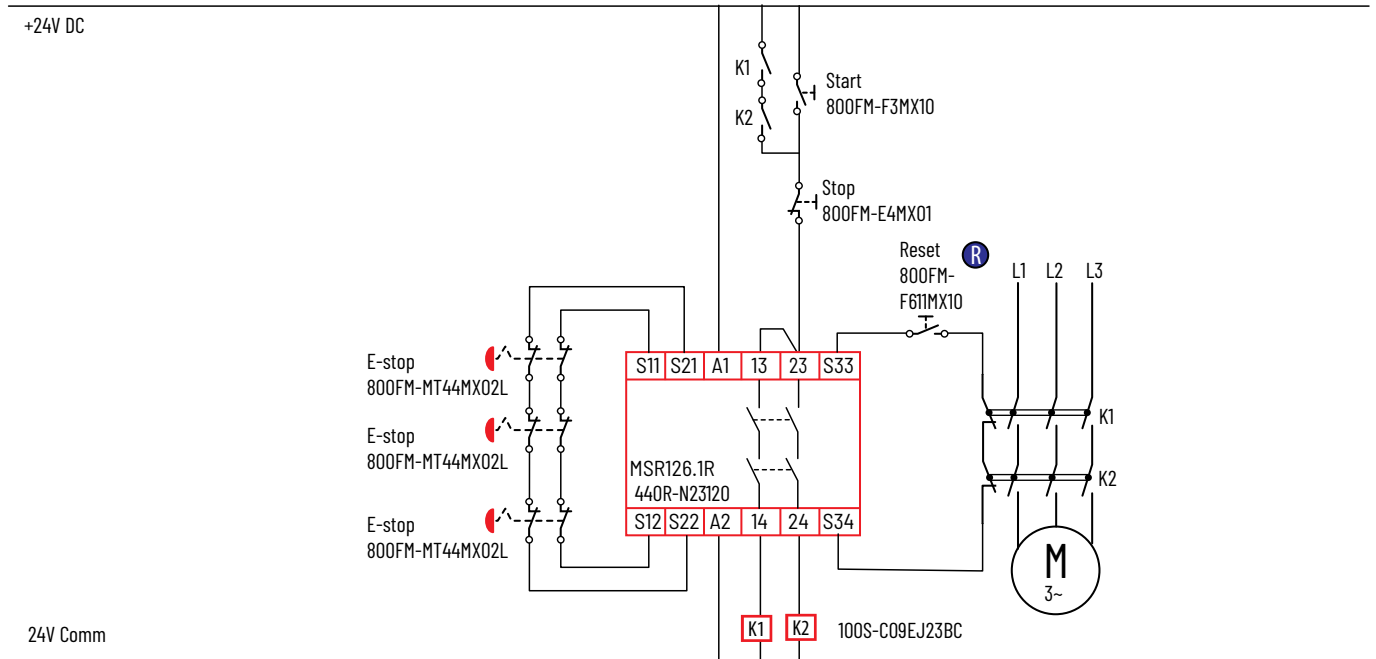

MSR126.1R Safety Relay with Trojan 5 Tongue Interlocks

Circuit Components

- 440K Trojan 5 tongue interlocks
- 440R MSR126.1R safety monitoring relay, with monitored manual reset
- 100S safety contactors

Circuit Description

The MSR126.1R monitors the position of an 440K tongue interlock switch having mechanical contacts and the status of two 700S safety control relays. A red pilot light indicates that the gate is open

Circuit Status

The gate is closed. The outputs of the MSR126 are de-energized and ready for reset. The motor is OFF.

Operating Principle

STARTING: Press the Reset button to energize the MSR126 outputs. If the safety control relays are OFF, then the MSR126 outputs energize. Press the Start button to energize the 700S safety control relays, which turn ON the motor.

STOPPING: Press the Stop button to accomplish a normal production stop. You can also press the E-stop to stop the motor.

Ratings

In [Figure 21](#), the single 440K interlock switch initiates a safety function that has a structure that meets Category 3 and can be used in systems that require Performance Levels up to PLd per ISO 13849-1. The circuit executes a Stop Category 0 per IEC 60204-1 and NFPA79.

In [Figure 22 on page 30](#), multiple 440K interlock switches are connected in series can limit the safety function to Category 1, PLc. Fault masking results in loss of diagnostic coverage, see ISO14119.

Figure 21 - MSR126.1R with Single Trojan 5 Tongue Interlock

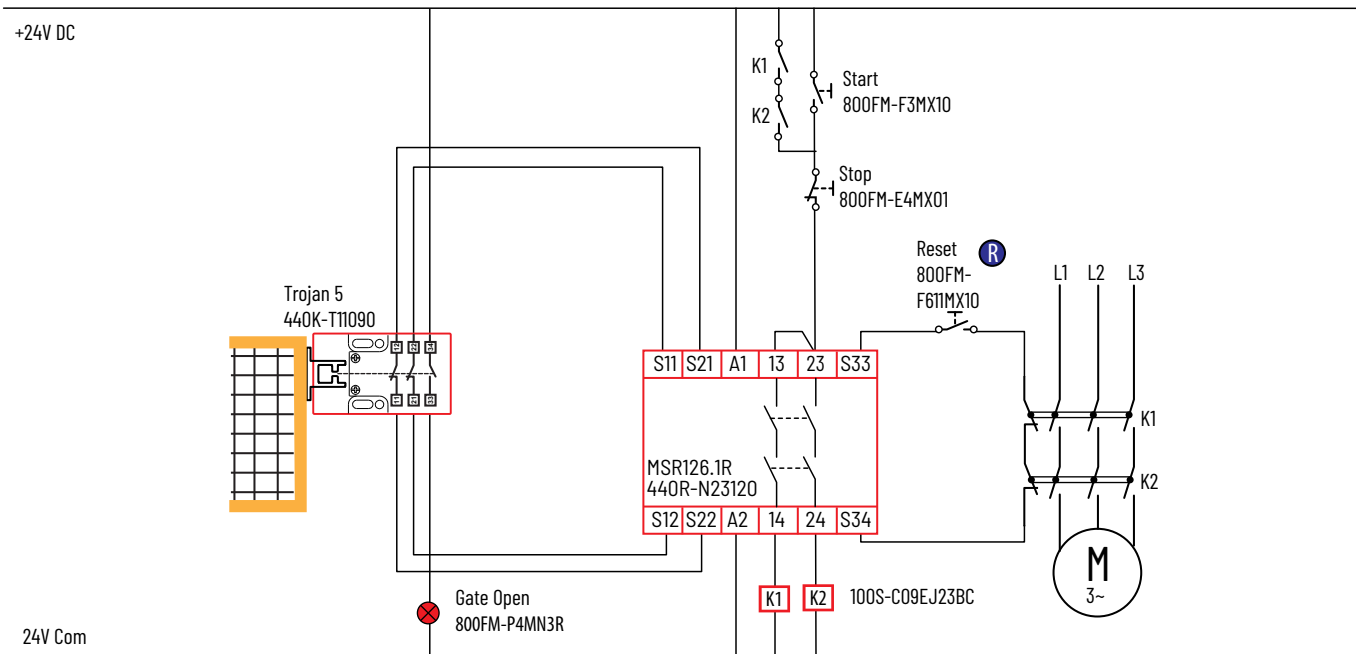
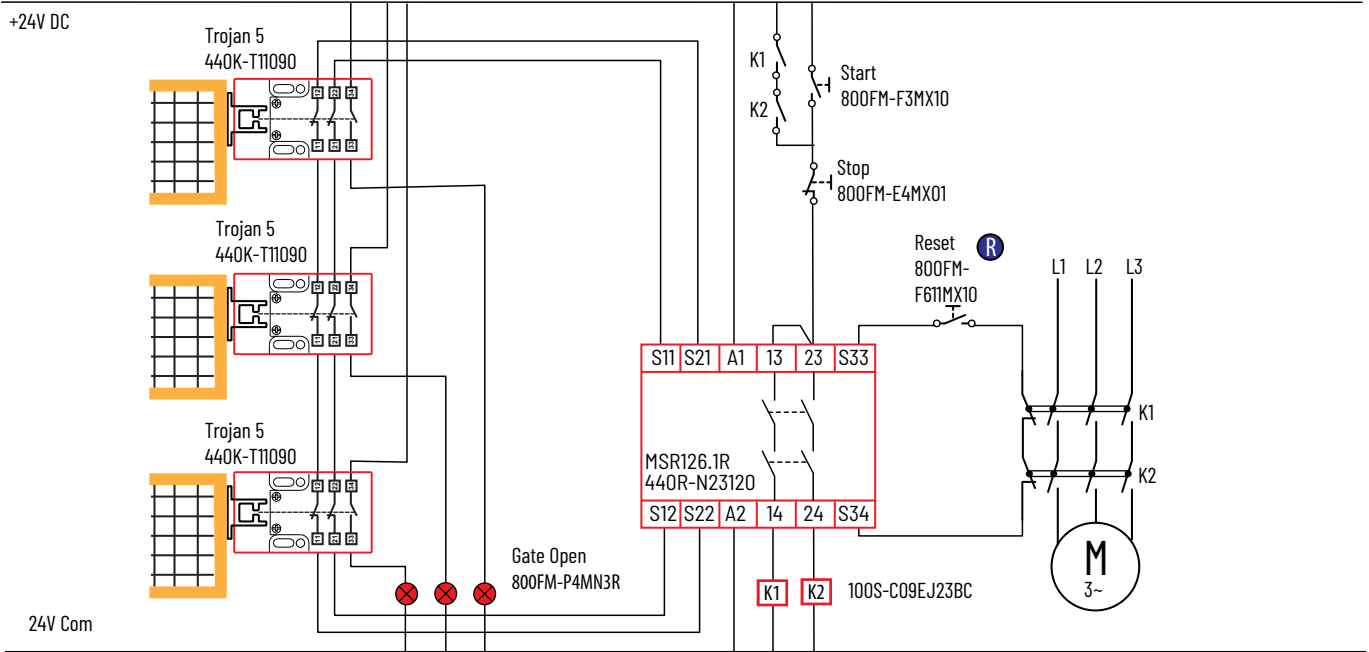

Figure 22 - MSR126.1R with Series Connection of Trojan 5 Tongue Interlocks



MSR126T Safety Relay with 450L Safety Light Curtain

Circuit Components

- 450L safety light curtain
- 800F push buttons
- 440R MSR126T safety monitoring relay, with automatic reset
- 100S safety contactors

Circuit Description

The MSR126T safety relay monitors the 450L safety light curtain and the status of two 100S safety contactors.

Circuit Status

An object in the sensing field blocks the safety light curtain. The outputs of the MSR126T safety relay are de-energized and ready for reset. The motor is OFF.

Operating Principle

STARTING: Clear the object from the safety light curtain, which energizes the MSR126T outputs. Press the Start button to energize the 100S contactors and the motor starts.

STOPPING: Press the Stop button to accomplish a normal production stop. If an object (for example, a person's hand) enters the safety light curtain field, the MSR126T outputs turn OFF, which drops out the 100S contactors, and the motor coasts to a stop.

Ratings

The safety light curtain initiates a safety function that has a structure that meets Category 4 and can be used in systems that require Performance Levels up to PLe per ISO 13849-1. The circuit executes a Stop Category 0 per IEC 60204-1 and NFPA79.

Figure 23 - MSR126T Safety Relay with 450L Safety Light Curtain

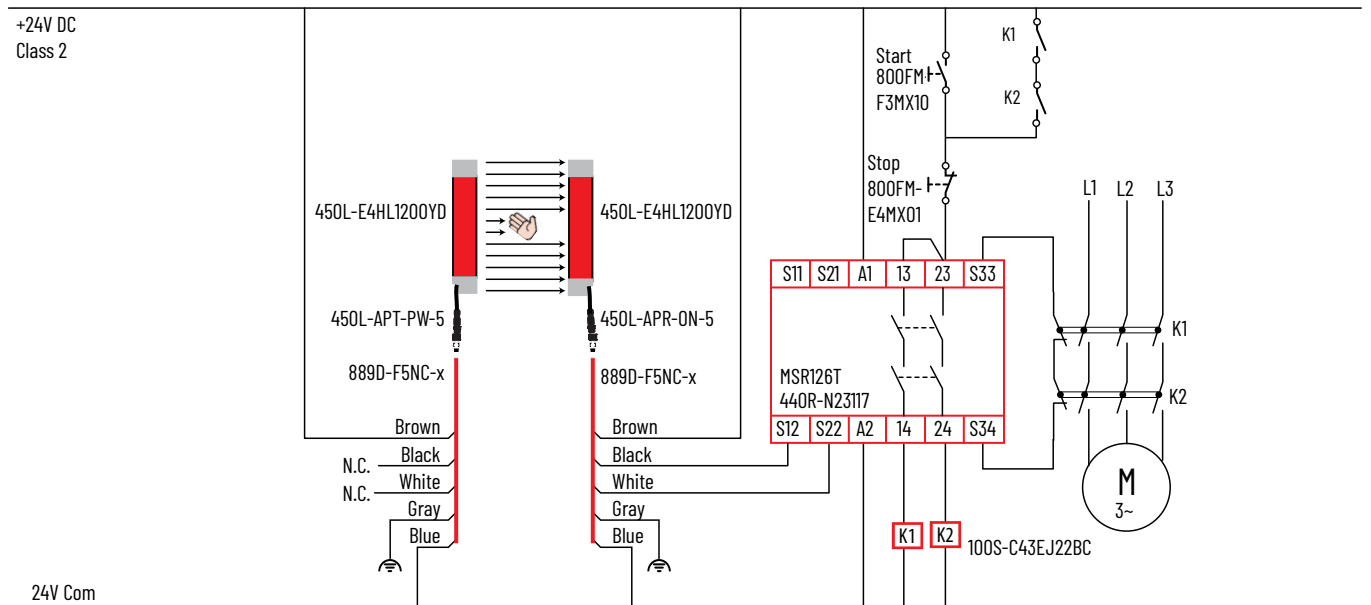

MSR126.1T Safety Relay with Lifeline 4 Cable Pull Switch

Circuit Components

- 440E Lifeline 4 cable pull switch
- 800F push buttons
- 440R MSR126T safety monitoring relay, with automatic reset
- 100S safety contactors

Circuit Description

The MSR126T monitors the 440E cable pull switch and the status of two 100S safety contactors. An 855D Control Tower™ stack light provides visual indication when the cable has been pulled.

Circuit Status

The cable is tensioned properly, and the Lifeline 4 contacts are closed. With the safety contactors de-energized, their normally closed contacts are closed allowing the MSR126 outputs to energize. The tension is set and the Lifeline 4 is tripped. The outputs of the MSR126 are de-energized and ready for reset. The motor is OFF.

Operating Principle

STARTING: Reset the Lifeline 4 cable pull switch by rotating the blue reset lever to the center position. The Lifeline 4 contacts close and energize the outputs of the MSR126 safety relay. Press the Start button to energize the 100S safety contactors and the motor starts.

STOPPING: Press the Stop button Normal to accomplish a normal production stop. Pull the cable to trip the Lifeline 4 switch. The MSR126 outputs turn OFF, which drops out the 100S safety contactors and the motor coasts to a stop.

Ratings

The cable pull switch initiates a safety function that has a structure that meets Category 3 and can be used in systems that require Performance Levels up to PLD per ISO 13849-1. The circuit executes a Category 0 stop per IEC 60204-1 and NFPA79.

Figure 24 - MSR126 with Lifeline 4

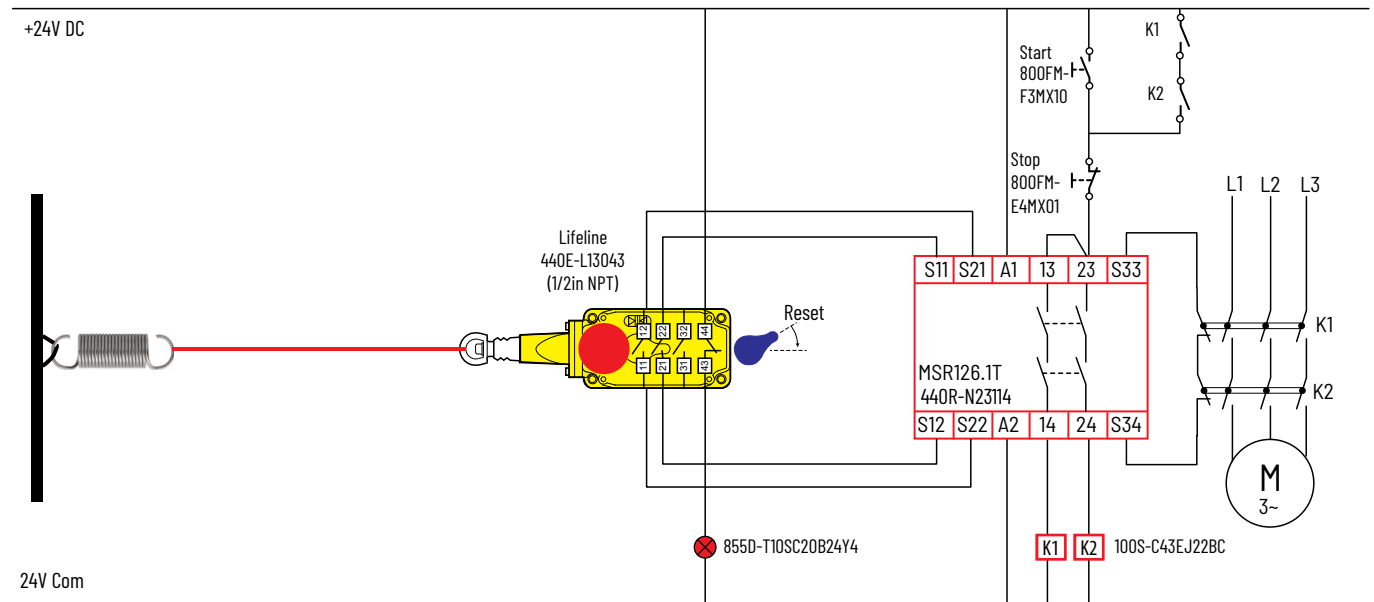

MSR127RP Safety Relay with Ferrogard Non-contact Interlock Switch

Circuit Components

- 440N-G non-contact Ferrogard GD2 stainless-steel interlock switch
- 440R MSR127RP safety monitoring relay, with monitored reset
- 100S safety contactors

Circuit Description

The MSR127 safety relay monitors the 800F E-stop and the status of two 100S safety contactors. An 800FM pilot light provides visual indication when the gate is open.

Circuit Status

The gate is closed. The MSR127 outputs are de-energized, and the 100S contactors are de-energized. The motor is OFF. The MSR127 safety relay is waiting for the Reset button to be pressed.

Operating Principle

STARTING: Press the Reset button to energize the output of the MSR127 safety relay. Press the Start button to energize the 100S safety contactors, and the motor is ON.

STOPPING: Press the Stop button to accomplish a normal production stop. Press the E-stop to de-energize the MSR127 outputs, which in turn de-energizes the 100S contactors, and the motor coasts to a stop.

Ratings

The Ferrogard GD2 switch initiates a safety function that has a structure that meets Category 4 and can be used in systems that require Performance Levels up to PLe per ISO 13849-1. The circuit executes a Category 0 stop per IEC 60204-1 and NFPA79.

Figure 26 - MSR127 Safety Relay with Ferrogard GD2

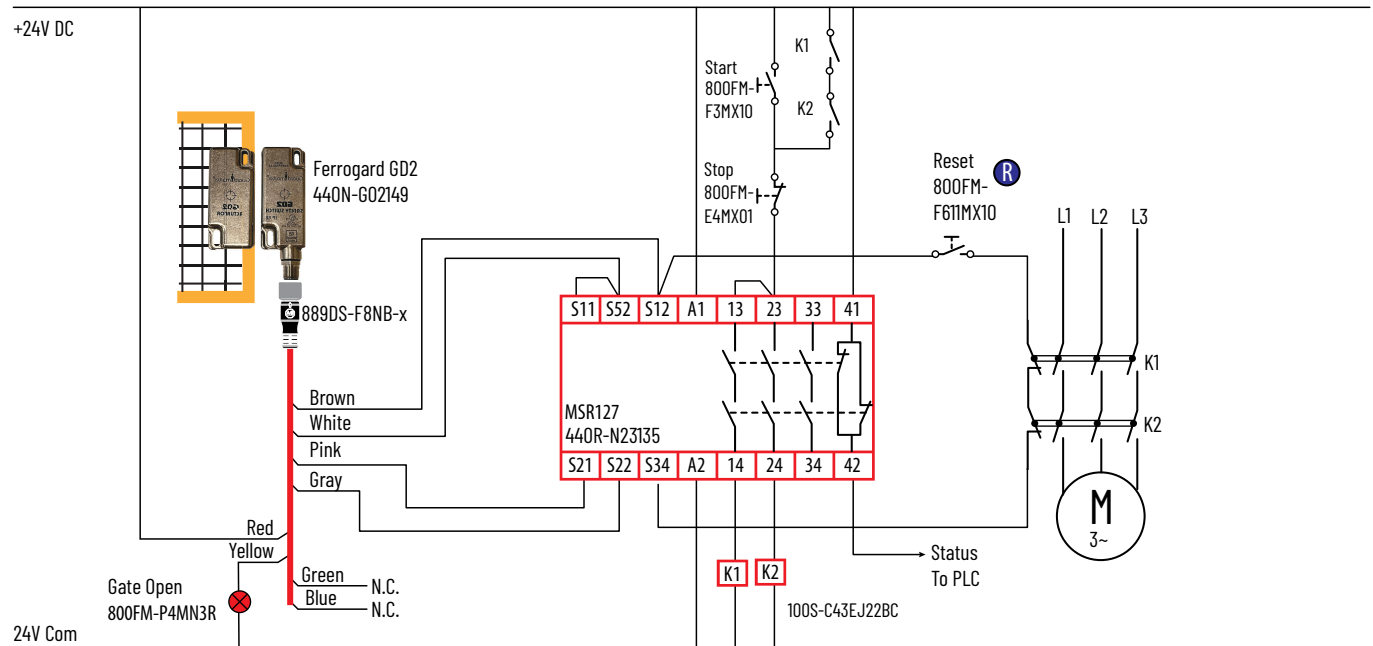

MSR127TP Safety Relay with 450L Safety Light Curtain

Circuit Components

- 450L safety light curtain
- 800F push buttons
- 440R MSR127TP safety monitoring relay, with automatic reset
- 100S safety contactors

Circuit Description

The MSR127 safety relay monitors the 450L safety light curtain and the status of two 100S safety contactors. The auxiliary MSR127 contacts provide status information back to the PLC.

Circuit Status

The safety light curtain protective field is blocked. The MSR127 outputs are de-energized, and the 100S contactors are de-energized. The motor is OFF.

Operating Principle

STARTING: Clear the safety light curtain protective field and the MSR127 outputs turn ON automatically. Press the Start button to energize the 100S safety contactors, and the motor is ON.

STOPPING: Press the Stop button to accomplish a normal production stop. Breaking the protective field of the safety light curtain de-energizes the MSR127 outputs, which in turn de-energizes the 100S contactors and the motor coasts to a stop.

Ratings

The 450L safety light curtain initiates a safety function that has a structure that meets Category 4 and can be used in systems that require Performance Levels up to PLe per ISO 13849-1. The circuit executes a Category 0 stop per IEC 60204-1 and NFPA79.

Figure 27 - MSR127 Safety Relay with 450L Safety Light Curtain

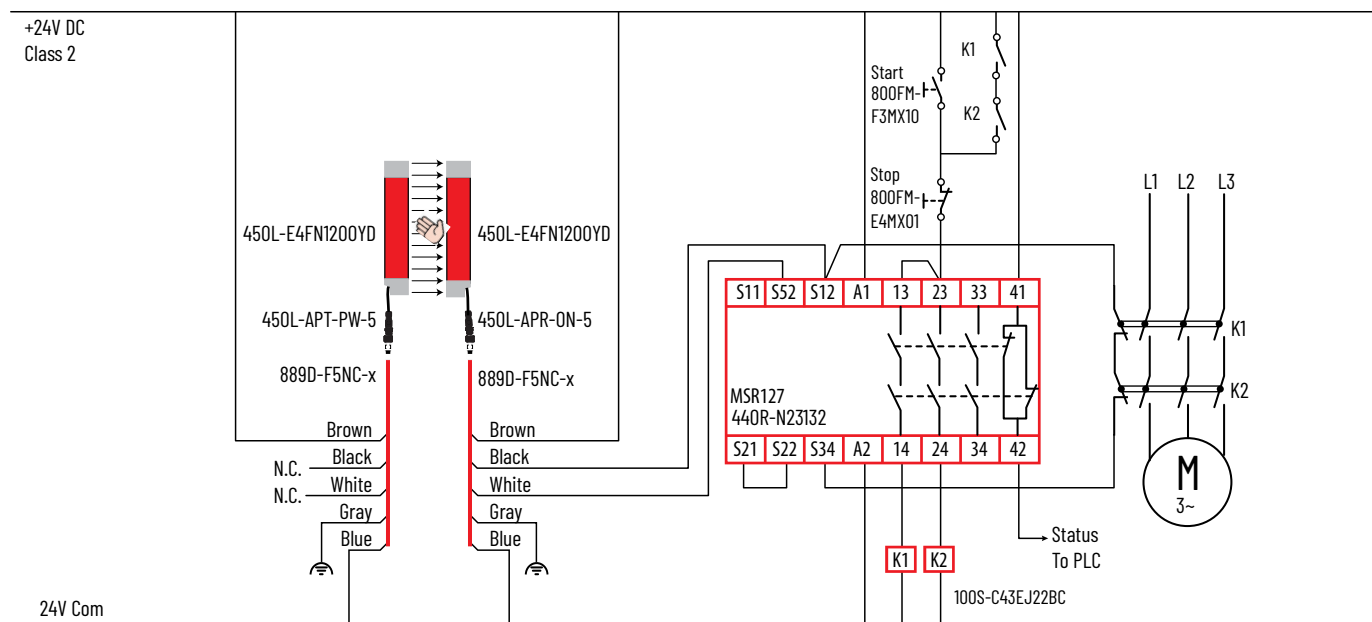

MSR127TP Safety Relay with 440N SensaGuard Switch with Integrated Latch

Circuit Components

- 440N SensaGuard switch with integrated latch
- 800F push buttons
- 440R MSR127TP safety monitoring relay, with automatic reset
- 25B PowerFlex 525 drive

Circuit Description

The MSR127 safety relay monitors the 440N SensaGuard interlock switch. The auxiliary MSR127 contacts provide status information back to the PLC. [Figure 28](#) uses the SensaGuard with a 5-pin connector. [Figure 29 on page 37](#) uses the 8-pin SensaGuard to connect the switches in series.

Circuit Status

The gate is open. The MSR127 outputs are de-energized, and the PowerFlex 525 drive Safe Torque inputs are open. The motor is OFF.

Operating Principle

STARTING: Close the gate. The MSR127 outputs close which allows the PowerFlex 525 drive to operate the motor. Press the Start button to run the motor at its pre-configured setting.

STOPPING: Press the Stop button to accomplish a normal production stop. Opening the gate causes the MSR127 outputs to open and the motor coasts to a stop.

Ratings

The gate interlock initiates a safety function that has a structure that meets Category 3 and can be used in systems that require Performance Levels up to PLd per ISO 13849-1 due to the rating of the PowerFlex 525 drive. The circuit executes a Category 0 stop per IEC 60204-1 and NFPA79.

Figure 28 - MSR127 Safety Relay with 440N SensaGuard Switch with Integrated Latch

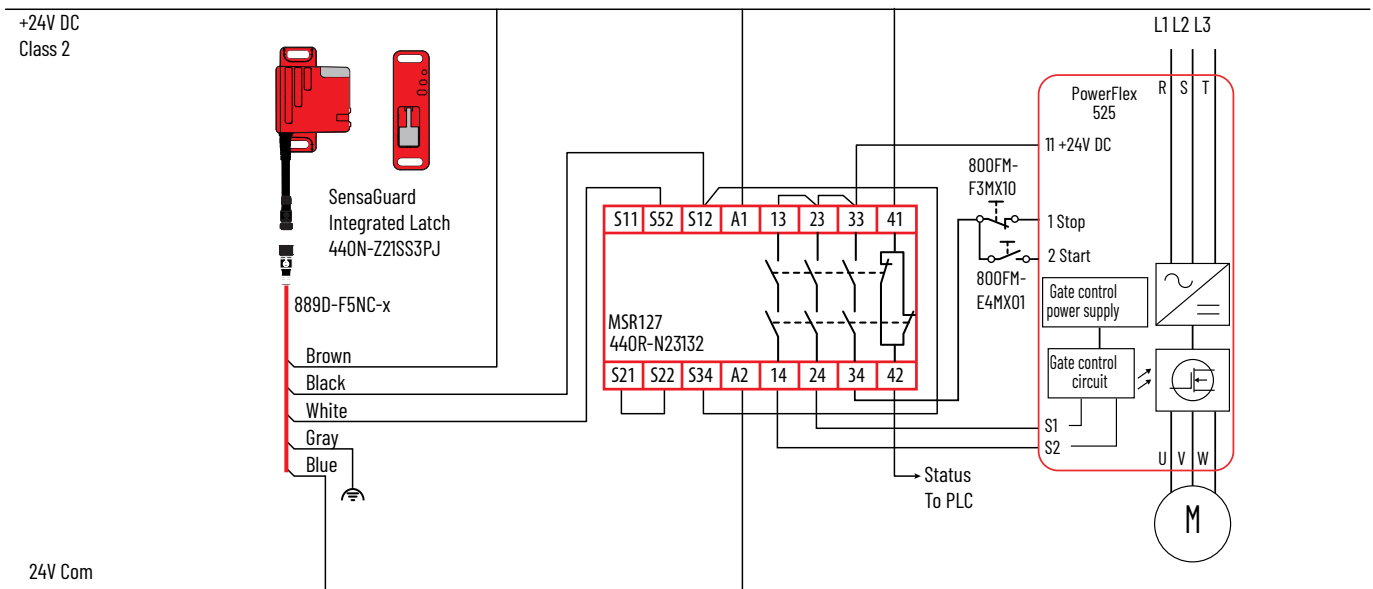
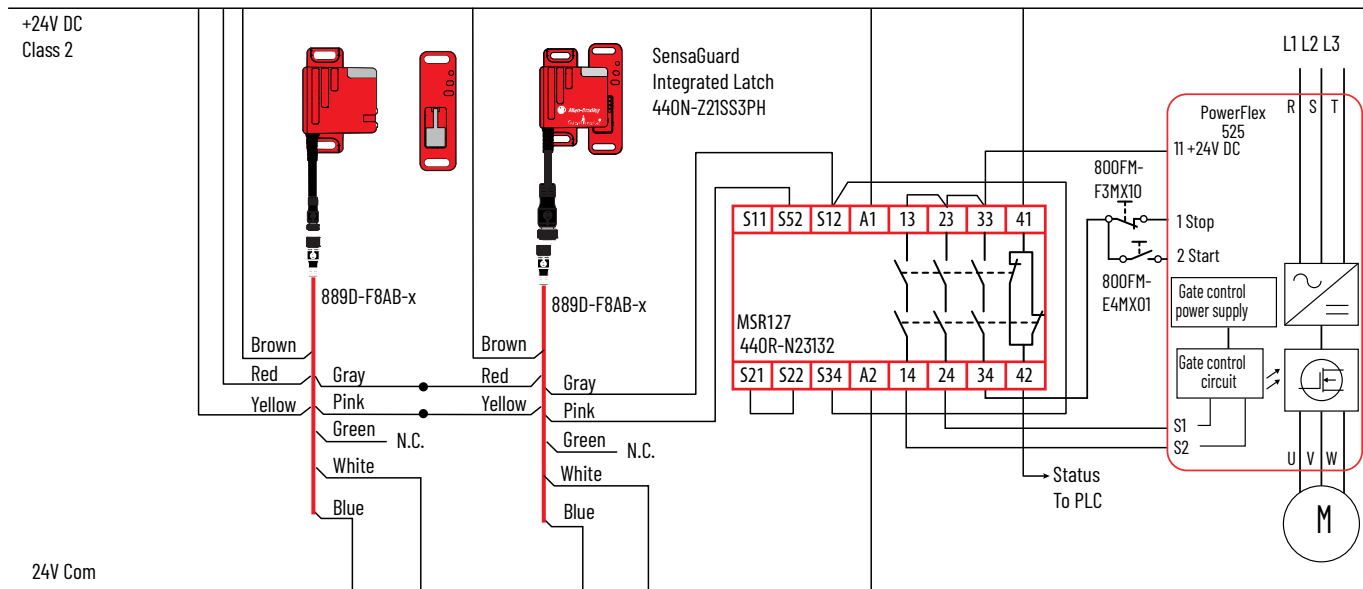

Figure 29 - MSR127 Safety Relay with Series Connection of 440N SensaGuard Switch with Integrated Latch



MSR131RTP Safety Relay with 440L GuardShield Safety Light Curtain

Circuit Components

- 440L GuardShield safety light curtain
- 800F push buttons
- 855D Control Tower stack lights
- 440R MSR131RTP safety monitoring relay
- 100S safety contactors

Circuit Description

The MSR131 safety relay monitors the 440L safety light curtain and the 100S contactors. The auxiliary MSR131 contacts provide status information back to the PLC.

Circuit Status

The 440L safety light curtain is blocked. The MSR131 safety outputs are de-energized, and the 100S contactors are OFF. The motor is OFF.

Operating Principle

STARTING: Clear the safety light curtain. The MSR131 safety outputs close. Press the Start button to turn ON the motor.

STOPPING: Press the Stop button to accomplish a normal production stop. Breaking the safety light curtain field also causes the motor coast to a stop.

Ratings

The 440L safety light curtain initiates a safety function that has a structure that meets Category 4 and can be used in systems that require Performance Level up to PLe per ISO 13849-1. The circuit executes a Category 0 stop per IEC 60204-1 and NFPA79.

Figure 30 - MSR131 with 440L Safety Light Curtain

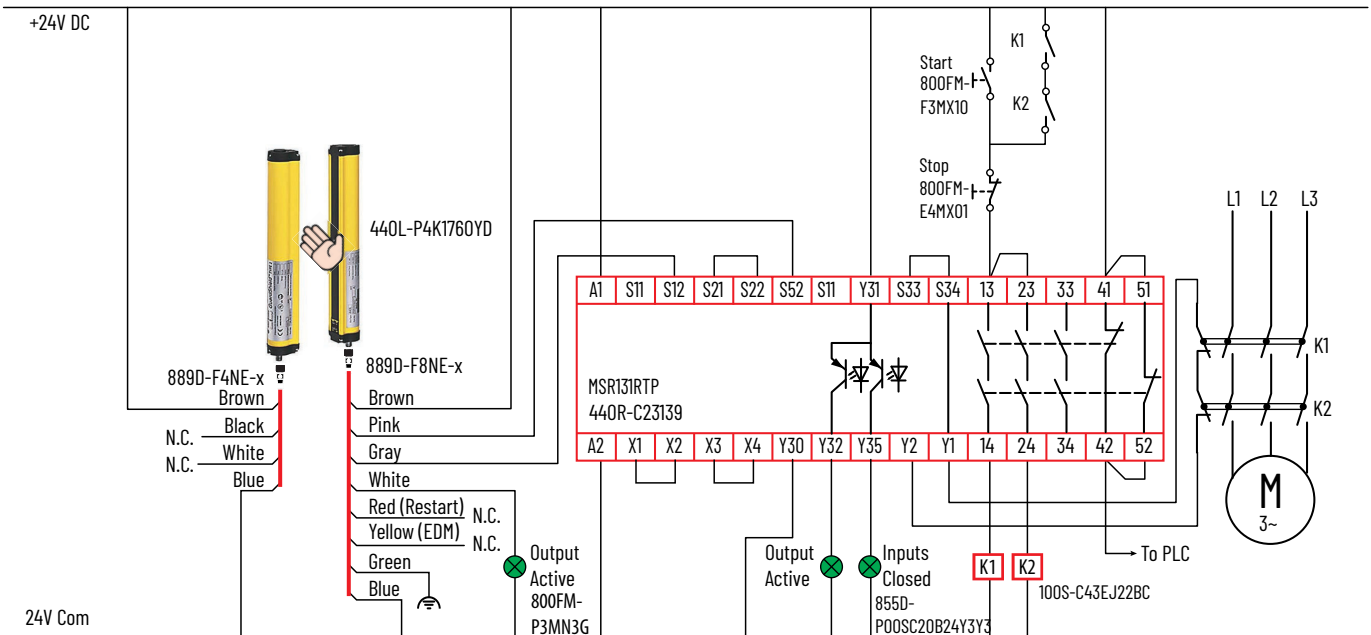

MSR131 Safety Relay with 440K Trojan T15 Switch and 800T E-stop

Circuit Components

- 440K Trojan T15 gate interlock switch
- 800T E-stop and push buttons
- 855D Control Tower stack lights
- 440R MSR131RTP safety monitoring relay
- 25B PowerFlex 525 drive

Circuit Description

The MSR131 monitors the 440K switch and the 800T E-stop. The auxiliary MSR131 contacts provide status information back to the PLC. The MSR131 is wired for monitored manual reset.

Circuit Status

The safety gate is closed, and the E-stop is released. The MSR131 safety outputs are de-energized and waiting for the Reset button to be pressed. The Safe Torque Off signals are OFF, and the motor is OFF.

Operating Principle

STARTING: Press the Reset button. The MSR131 safety outputs close and provide 24V to the Start/Stop circuit and safe torque inputs of the PowerFlex 525 drive. Press the Start button to turn ON the motor.

STOPPING: Press the Stop button to accomplish a normal production stop. Opening the safety gate or pressing the E-stop causes the motor coast to a stop.

Ratings

The 440K switch and 800T E-stop initiate a safety function that has a structure that meets Category 3 and can be used in systems that require Performance Level up to PLd per ISO 13849-1. The circuit executes a Category 0 stop per IEC 60204-1 and NFPA79.

Figure 31 - MSR131RTP with Trojan T15 and 800T E-stop

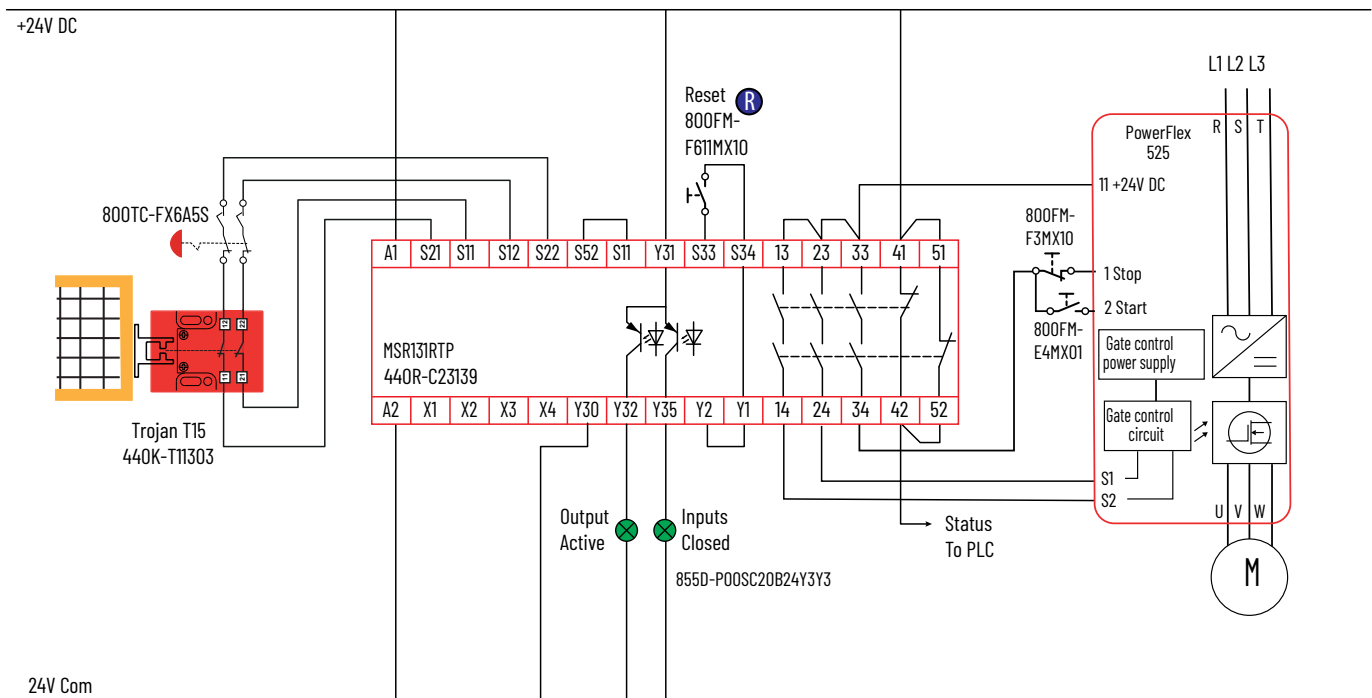

MSR138.1DP Safety Relay with TLS1-GD2 Guard Locking Interlock Switch

Circuit Components

- 440G TLS1-GD2 guard locking gate interlock switch
- 800FM E-stop, push buttons, and pilot lights
- MSR138.1DP safety monitoring relay with immediate and delayed contacts
- 100S safety contactors

Circuit Description

The MSR138 safety relay monitors the TLS1-GD2 switch and the 700S-C safety control relays. The delayed normally closed contact of the MSR138 safety relay allows the gate to be unlocked after the delay timer expires. The MSR138 safety relay is wired for monitored manual reset.

Circuit Status

The safety gate is closed and locked. The MSR138 immediate and delayed safety outputs are de-energized and waiting for the Reset button to be pressed. The 700S safety control relays are OFF, and the motor is OFF.

Operating Principle

STARTING: Press the Reset button. The MSR138 safety outputs close. Press the Start button to energize the 700S safety control relays, which turn ON the motor.

STOPPING: Press the Stop button to accomplish a normal production stop. Press the E-stop to turn OFF the MSR138 outputs and cause the motor coast to a stop. After the delay timer expires, the gate can be unlocked by the 800FM selector switch

Ratings

The gate interlock initiates a safety function that has a structure that meets Category 3 and can be used in systems that require Performance Level up to PLd per ISO 13849-1. The locking function has a structure that meets Category 2 and PLd. The circuit executes a Category 0 stop per IEC 60204-1 and NFPA79.

Figure 32 - MSR138.1DP Safety Relay with TLS1-GD2 Switch and 800F E-stop

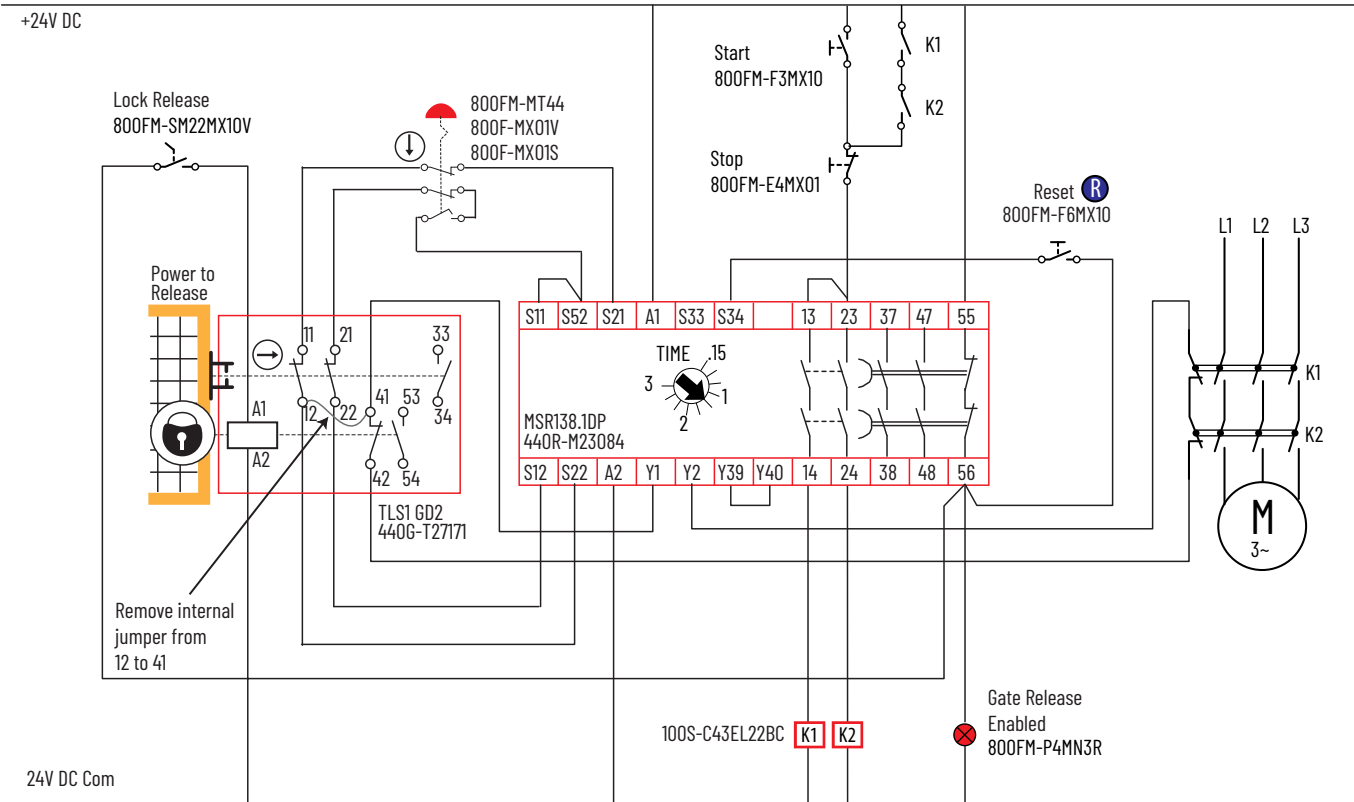

MSR138.1DP Safety Relay with Multifunction Access Box and E-stop

Circuit Components

- 442G multifunction access box (MAB)
- 800F E-stop switch
- 855D Control Tower stack lights
- MSR138.1DP safety monitoring relay with delayed outputs
- 25B PowerFlex 525 drive

Circuit Description

The MSR138 safety relay monitors the E-stop and guard. The auxiliary MSR131 contacts provide status information back to the PLC. The MSR138 safety relay is wired for automatic reset.

Circuit Status

The E-stop is released and the guard is closed but not locked. The MSR138 safety outputs are de-energized and waiting for the MAB to be locked. The PowerFlex 525 drive is OFF, and the motor is OFF.

Operating Principle

STARTING: Open the Lock Release switch. The MSR138 safety outputs close and provide 24V to the Start/Stop switches and safe torque inputs of the PowerFlex 525 drive. Press the Start button to energize the motor at its pre-configured speed.

STOPPING: Press the Stop button to accomplish a normal production stop. Press the E-stop to immediately remove power to the Start/Stop circuit. The PowerFlex 525 executes its pre-configured stop (for example, ramp to stop). After the time delay expires, the MSR138 safety relay removes power to the Safe Torque Off inputs of the PowerFlex drive, and provides power to the Lock Release button. The motor then coasts to a stop (if not already stopped).

Ratings

The MAB and E-stop initiate a safety function that has a structure that meets Category 3 and can be used in systems that require Performance Level up to PLd per ISO 13849-1. The locking function has a structure meeting Category 2 and PLd. The circuit executes a Stop Category 1 per IEC 60204-1 and NFPA79.

Figure 33 - MSR138.1DP Safety Relay with MAB and 800F E-stop

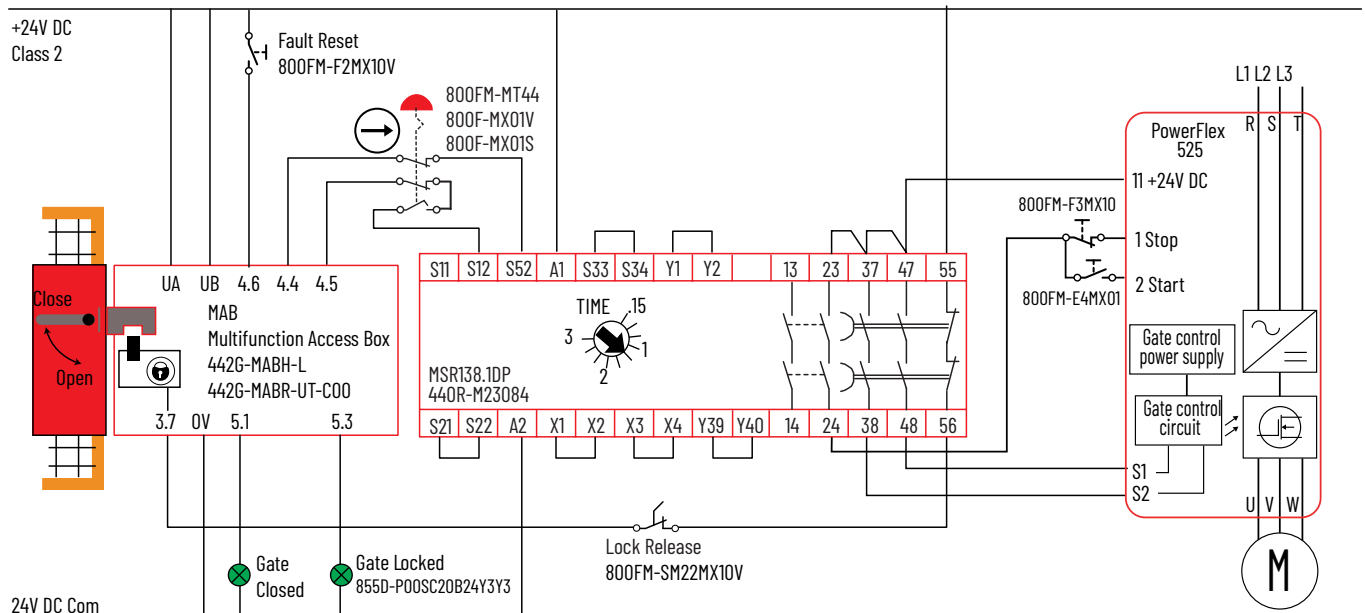

MSR138.1DP Safety Relay with MAB (Integral Buttons)

Circuit Components

- 442G multifunction access box (MAB)
- 800F push buttons
- MSR138.1DP safety monitoring relay with delayed outputs
- 25B PowerFlex 525 drive

Circuit Description

The MSR138 safety relay monitors the integrated E-stop and the safety outputs of the MAB. The MSR138 safety relay is wired for monitored manual reset.

Circuit Status

The E-stop is released and the guard is closed but not locked. The MSR138 safety outputs are de-energized and waiting for the MAB to be locked. The PowerFlex 525 drive is OFF, and the motor is OFF.

Operating Principle

STARTING: Release the Unlock button. The MSR138 safety outputs close and provide 24V to the Start/Stop circuit and the safe torque inputs of the PowerFlex 525 drive. Press the Start button to energize the motor at its pre-configured speed.

STOPPING: Press the Stop button to accomplish a normal production stop. Press the E-stop button to immediately remove power to the Start/Stop circuit. The PowerFlex 525 executes its pre-configured stop (for example, ramp to stop). After the time delay expires, the MSR138 safety relay removes power to the Safe Torque Off inputs of the PowerFlex drive, and provides power to the Lock Release button. The motor then coasts to a stop (if not already stopped).

Ratings

The MAB and E-stop initiate a safety function that has a structure that meets Category 3 and can be used in systems that require Performance Level up to PLd per ISO 13849-1. The locking function has a structure meeting Category 2 and PLd. This circuit executes a Stop Category 1 per IEC 60204-1 and NFPA79.

Figure 34 - MSR138.1DP Safety Relay with MAB (Integral Buttons)

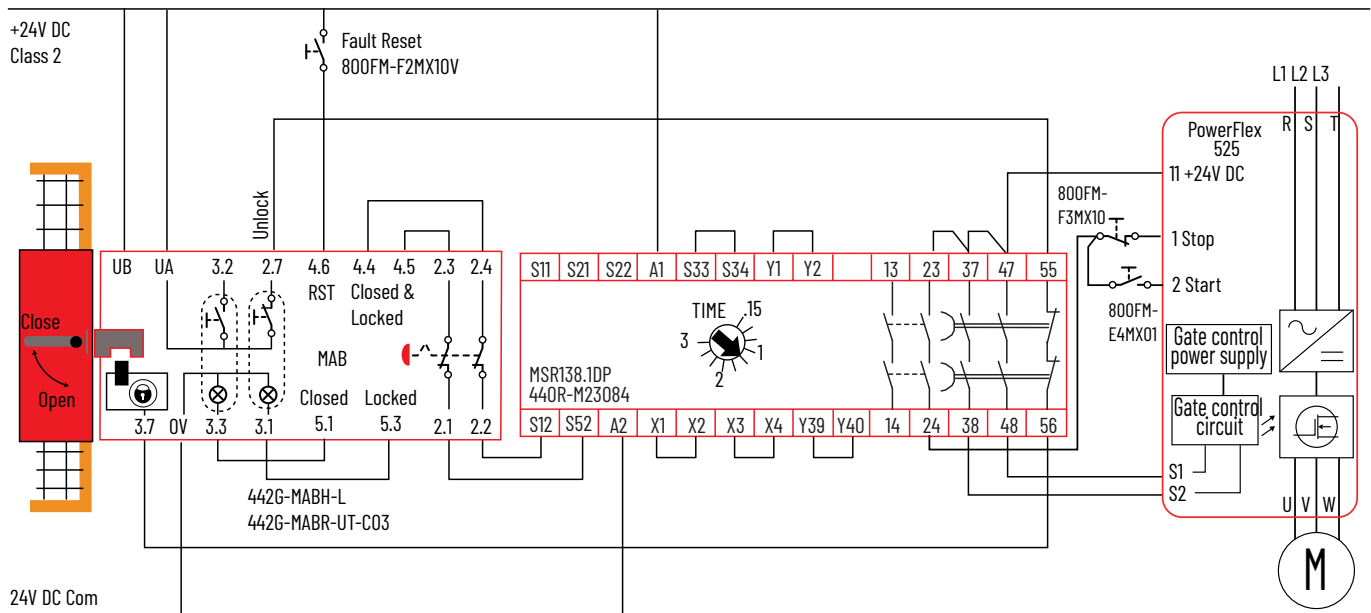

MSR138.1DP Safety Relay with 440G-MZ Guard Locking Interlock and 800F E-stop

Circuit Components

- 440G-MZ guard locking interlock switch
- 800F E-stop and push buttons
- MSR138.1DP safety monitoring relay with delayed outputs
- 25B PowerFlex 525 drive

Circuit Description

The MSR138 safety relay monitors the E-stop and the guard locking interlock switch. The MSR138 safety relay is wired for automatic reset.

Circuit Status

The guard door is open, and the E-stop is released. The MSR138 safety outputs are de-energized. The PowerFlex 525 drive is OFF, and the motor is OFF.

Operating Principle

STARTING: Close the gate. The gate locks and the MSR138 safety outputs close to provide 24V to the stop/start circuit and the safe torque inputs of the PowerFlex 525 drive. Press the Start button to turn ON the motor.

STOPPING: Press the Stop button to accomplish a normal production stop. You can also press the E-stop to accomplish a stop. Pressing the E-stop causes the MSR138 safety relay to issue an immediate stop command. After the delay time expires, the Safe Torque Off signals to the PowerFlex 525 drive turn OFF, and the Unlock selector switch can unlock the gate. With the 440G-MZ switch unlocked, the motor cannot be restarted as the STO inputs remain OFF.

Ratings

The E-stop and gate interlock initiate a safety function that has a structure that meets Category 3 and can be used in systems that require Performance Level up to PLd per ISO 13849-1. The locking function has a structure meeting Category 2 and PLd. This circuit executes a Stop Category 1 per IEC 60204-1 and NFPA79.

Figure 35 - MSR138.1DP Safety Relay with 440G-MZ and 800F E-stop

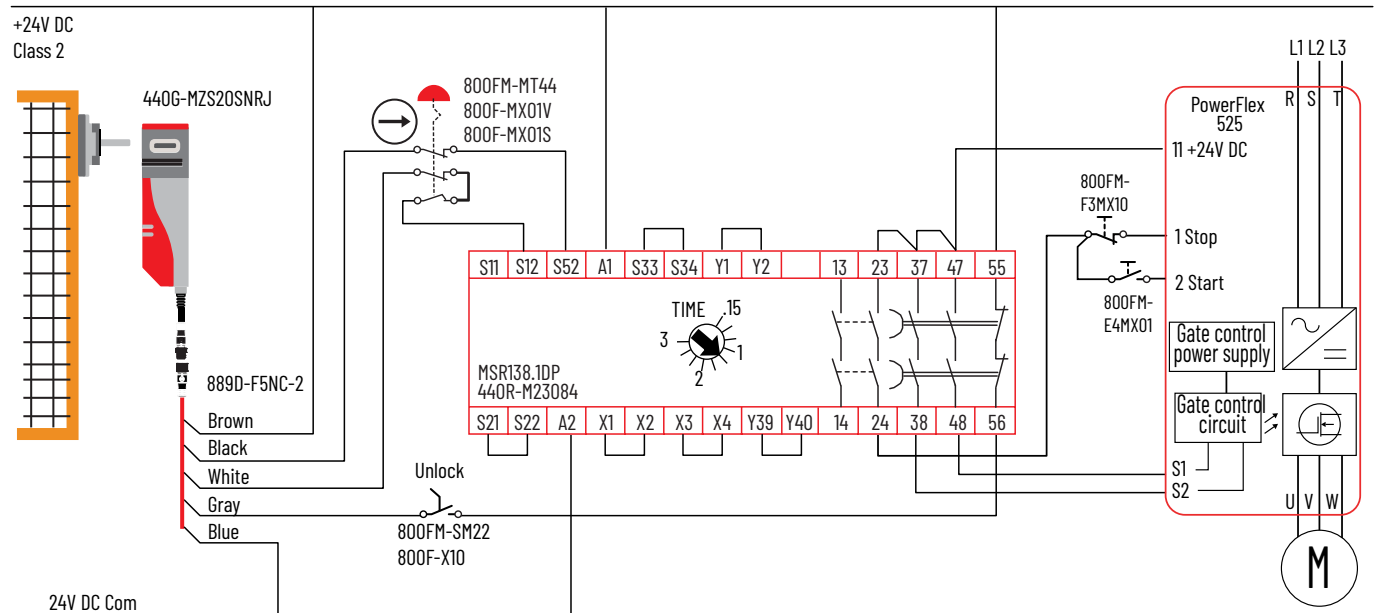

MSR138.1DP Safety Relay with 440G-LZ, 440G-TZ, and 800F E-stop

Circuit Components

- 440G-LZ guard locking interlock switch, Power to Release
- 440G-TLSZ guard locking interlock switch, Power to Release
- 800F E-stop and push buttons
- 855D Control Tower stack light
- MSR138.1DP safety monitoring relay with delayed outputs
- 100S safety contactors

Circuit Description

The MSR138 safety relay monitors the series connection of two guard locking interlocks, an E-stop, and the feedback from the 100S safety contactors. The MSR138 safety relay is wired for monitored manual reset.

Circuit Status

The guard doors are closed and locked, and the E-stop is released. The MSR138 safety outputs are de-energized and waiting for the Reset button to be pressed. The 100S safety contactors are OFF, and the motor is OFF.

Operating Principle

STARTING: Press the Reset button. The MSR138 safety outputs close and provide 24V to the 100S safety contactors. External circuitry controls the starting of the motor.

STOPPING: The external circuitry accomplishes a normal production stop. Pressing the E-stop causes the MSR138 contacts to open and the 100S safety contactors to turn OFF. The motor coasts to a stop (if not already stopped). The safety gates can then be unlocked.

Ratings

The E-stop and gate interlocks initiate a safety function that has a structure that meets Category 3 and can be used in systems that require Performance Level up to PLd per ISO 13849-1. The locking function has a structure meeting Category 2 and PLd. This circuit executes a Stop Category 0 per IEC 60204-1 and NFPA79.

Figure 36 - MSR138.1DP Safety Relay with 440G-LZ/440G-TZ Switch, and 800F E-stop

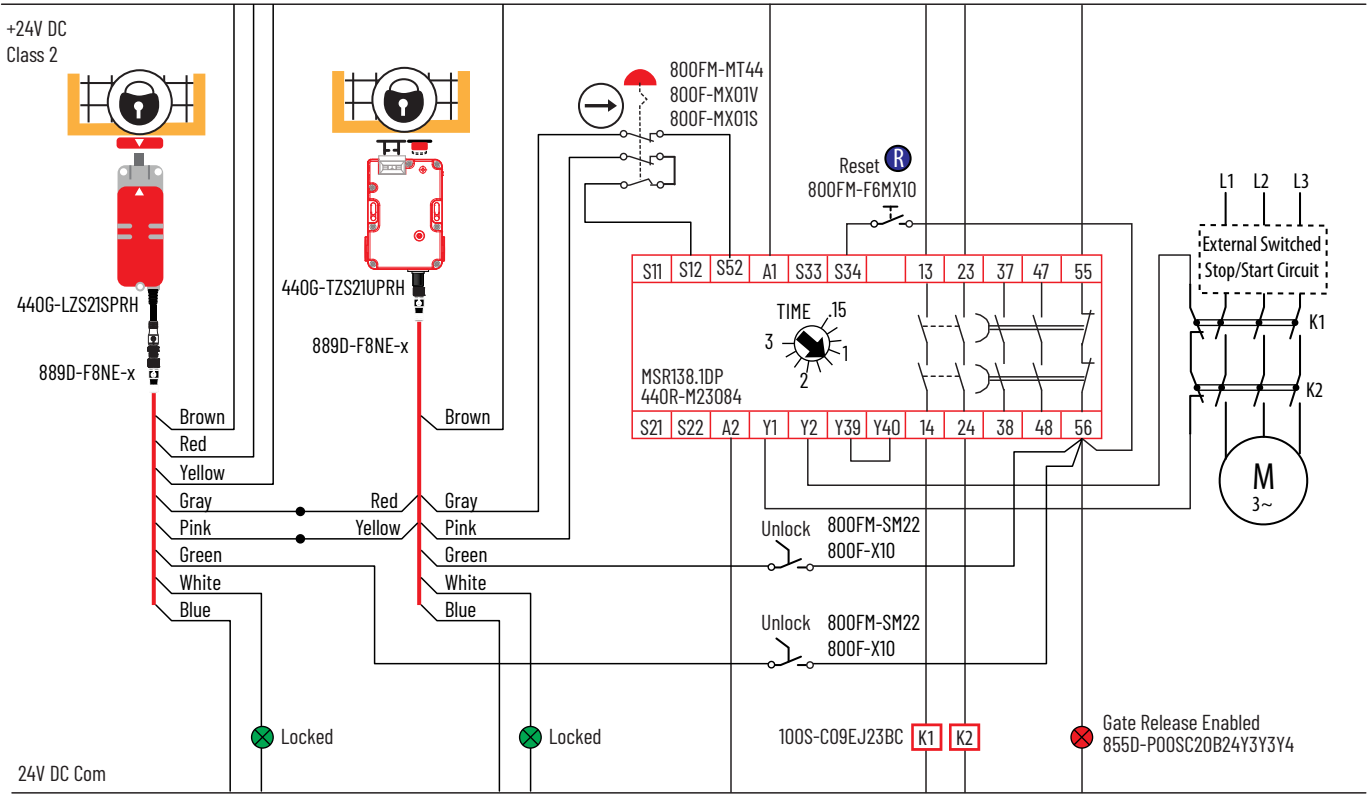

MSR142RTP Safety Relay with 440K Trojan T15 Switch and 800T E-stop

Circuit Components

- 440K Trojan T15 guard interlock switch
- 800T E-stop
- 800F push button
- MSR142RTP safety monitoring relay
- 700S safety control relays

Circuit Description

The MSR142 monitors the guard interlock switch, the E-stop, and series connection of feedback contacts of the 700S control relays. The MSR142 is wired for monitored manual reset.

Circuit Status

The guard door is closed, and the E-stop is released. The MSR142 safety outputs are de-energized and waiting for the Reset button to be pressed. The 700S safety control relays are OFF.

Operating Principle

STARTING: Press the Reset button. If all seven safety control relays are OFF, the MSR142 safety outputs close and provide 24V to the safety control relays. Additional circuitry (not shown) is required to energize the loads (not shown) controlled by K1...K7.

STOPPING: The external circuitry (not shown) accomplishes a normal production stop. Opening the gate or pressing the E-stop de-energizes the K1...K7 relays.

Ratings

Due to the series connection of the gate and E-stop, the E-stop and gate interlock initiate a safety function that has a structure that meets Category 3 and can be used in systems that require Performance Level up to PLd per ISO 13849-1. This circuit executes a Stop Category 0 per IEC60204-1 and NFPA79.

Figure 37 – MSR142 with 440K Trojan T15 and 800TC E-stop

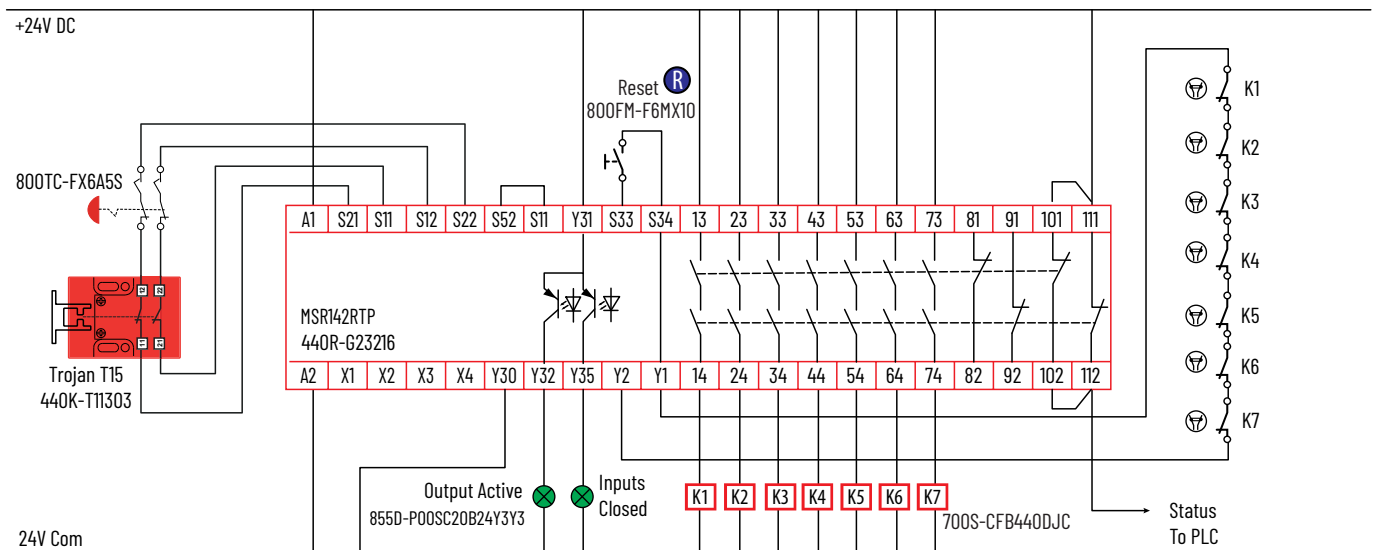

MSR142RTP Safety Relay with 450L Safety Light Curtain

Circuit Components

- 450L GuardShield safety light curtain
- 855D Control Tower stack light
- MSR142RTP safety monitoring relay
- 700S safety control relays

Circuit Description

The MSR142 monitors the 450L safety light curtain and the series connection of feedback contacts of the 700S control relays. The MSR142 is wired for automatic reset.

Circuit Status

The safety light curtain protective field is occupied. The MSR142 safety outputs are de-energized and the 700S safety control relays are OFF.

Operating Principle

STARTING: Removing the hand from the safety light curtain allows the MSR142 safety outputs to close provided all seven safety control relays are OFF, and the safety control relays (K1...K7) energize. Additional circuitry (not shown) is required to energize the loads (not shown) controlled by K1 through K7

STOPPING: The external circuitry (not shown) accomplishes a normal production stop. The K1 through K7 relays are de-energized by breaking the protective field of the safety light curtain.

Ratings

The safety light curtain initiates a safety function that has a structure that meets Category 4 and can be used in systems that require Performance Level up to PLe per ISO 13849-1. However, the safety rating needs further evaluation with the additional circuitry (not shown). This circuit executes a Stop Category 0 per IEC 60204-1 and NFPA79.

Figure 38 - MSR142 with 450L Safety Light Curtain

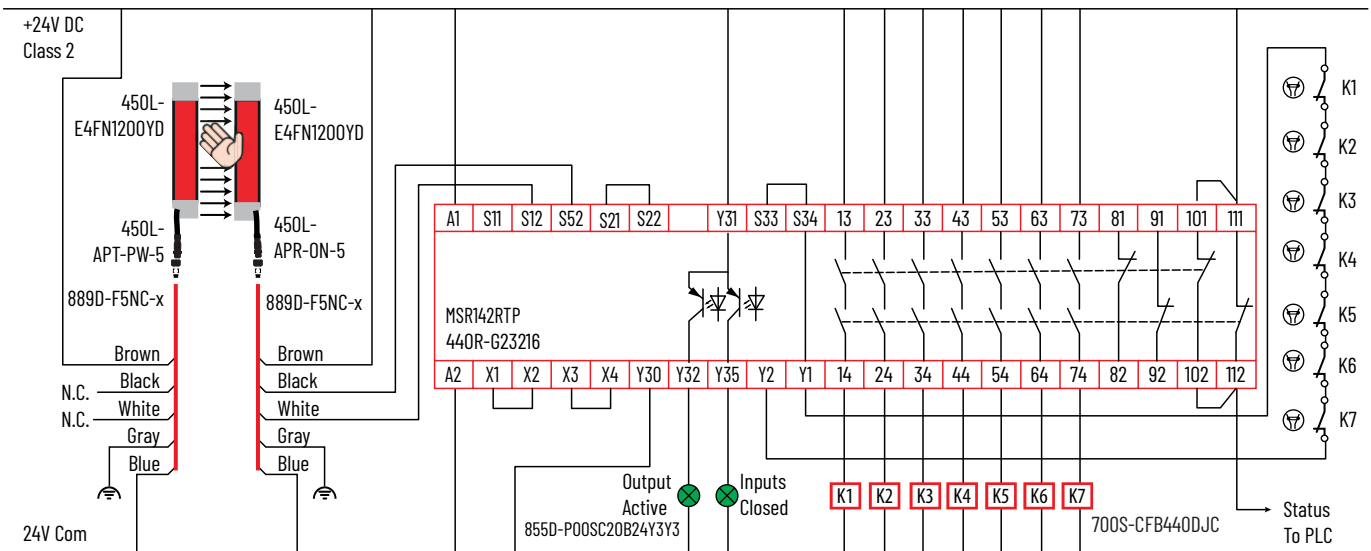

440F-C4000 Safety Mat Controller

Circuit Components

- 440F safety mat
- 800F push buttons and pilot lights
- 440F safety mat monitoring relay
- 100S safety contactors

Circuit Description

The safety mat controller monitors the safety mat and the series connection of feedback contacts of the 100S safety contactors. The internal reset switch of the safety mat controller is set to manual reset. The auxiliary contacts, 31/32, send a signal to the PLC and turn ON an indicator to indicate the mat is clear.

Circuit Status

The safety mat is not occupied. The safety mat controller safety outputs are de-energized, and the 100S safety contactors are OFF. The safety mat controller is waiting for the Reset button to be pressed.

Operating Principle

STARTING: With the mat unoccupied, press the Reset button. The safety mat controller contacts close. Press the Start button to energize the 100S safety contactors and start the motor.

STOPPING: Press the Stop button to accomplish a normal production stop. Stepping on the mat de-energizes the safety mat controller outputs and the motor coasts to a stop.

Ratings

Stepping on the safety mat initiates a safety function that has a structure that meets Category 3 and can be used in systems that require Performance Level up to PLd per ISO 13849-1. This circuit executes a Stop Category 0 per IRC 60204-1 and NFPA79.

Figure 39 - 440F-C4000P with 440F Safety Mat

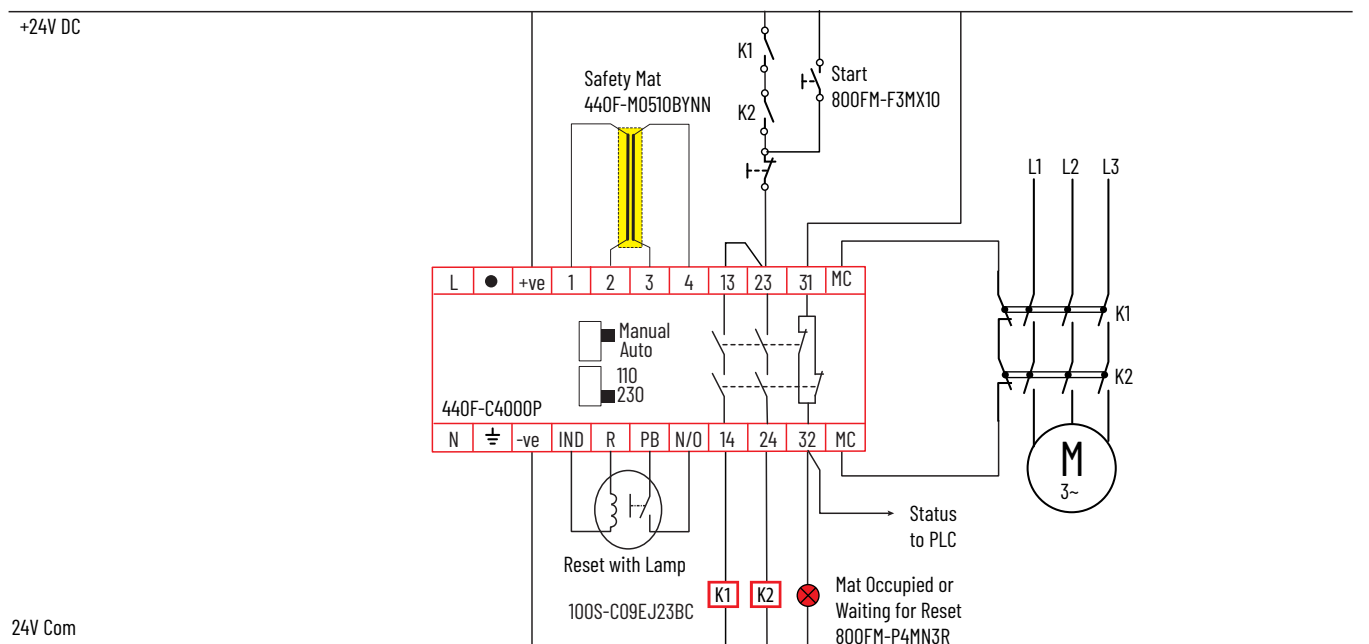

440F-C Mat Manager

Circuit Components

- 440F safety mat
- 800F push buttons and pilot lights
- 440F safety mat manager
- 100S safety contactors

Circuit Description

The safety mat manager monitors up to eight safety mats and the series connection of feedback contacts of the 100S safety contactors. The internal reset switch of the safety mat controller is set to manual reset. The auxiliary contacts, 4/10, send a signal to the PLC to indicate the mat is occupied or waiting for reset.

Circuit Status

The safety mat is not occupied. The 440F-C safety outputs are de-energized, and the 100S safety contactors are OFF. The 440F-C is waiting for the Reset button to be pressed.

Operating Principle

STARTING: With the mats unoccupied, press the Reset button. The 440F-C contacts close. Press the Start button to energize the 100S safety contactors and start the motor.

STOPPING: Press the Stop button to accomplish a normal production stop. Stepping on any of the mats de-energizes the 440F-C outputs, and the motor coasts to a stop.

Ratings

Stepping on any of the safety mats initiates a safety function that has a structure that meets Category 3 and can be used in systems that require Performance Level up to PLd per ISO 13849-1. This circuit executes a Stop Category 0 per IEC 60204-1 and NFPA79.

Figure 40 - Mat Manager

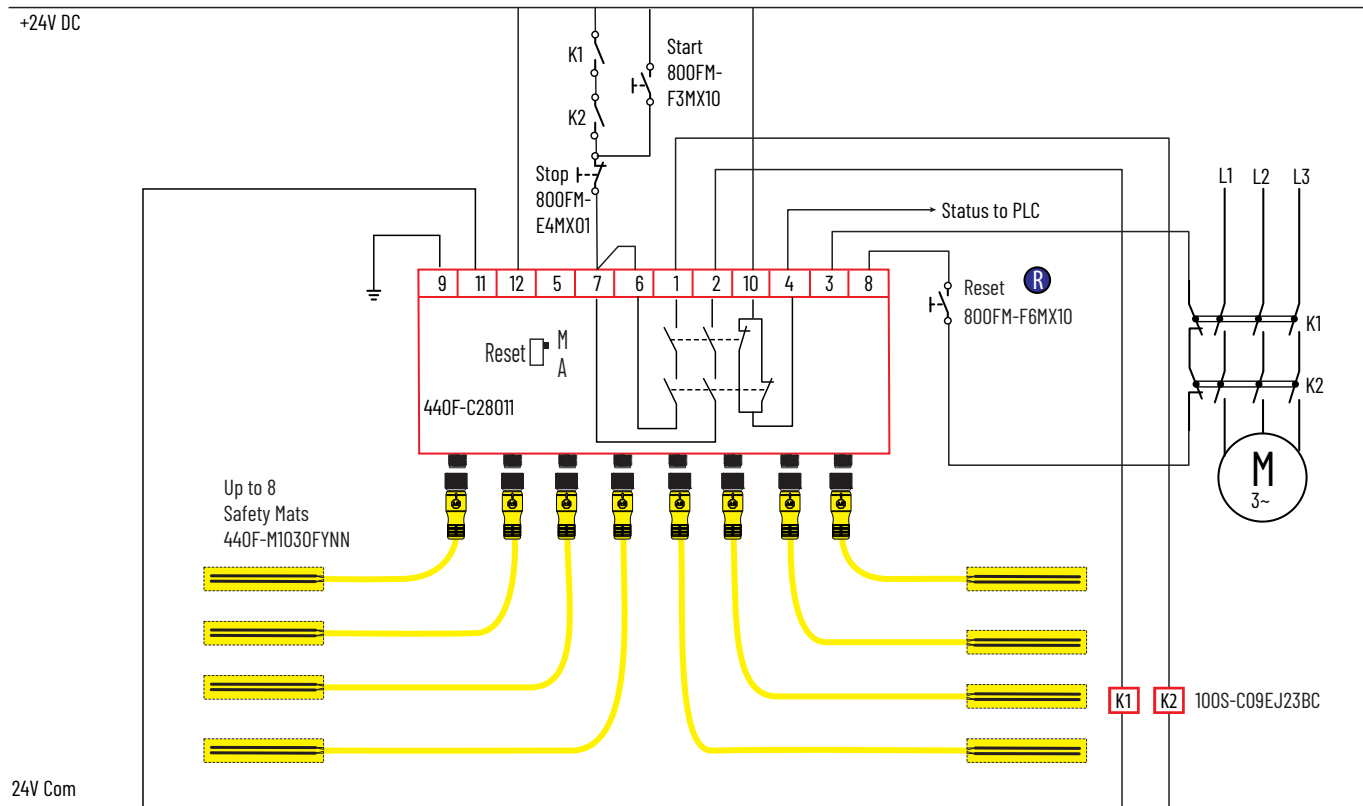

440F-C251D, P with Safedge Profiles

Circuit Components

- 440F safety edge
- 800F push buttons and pilot lights
- 440F safety edge monitoring relay
- 100S safety contactors

Circuit Description

The safety edge relay monitors the safety edges and the series connection of feedback contacts of the 100S safety contactors. In this example, two safety edges are connected in series: the edge closest to the relay is a 4-wire configuration and the edge furthest away from the relay is a 2-wire with a 6K terminating resistor. The auxiliary contacts, 31/32, indicate that the edge is either pressed or waiting for reset.

Circuit Status

The safety edge is not pressed. The 440F safety outputs are de-energized, and the 100S safety contactors are OFF. The 440F is waiting for the Reset button to be pressed.

Operating Principle

STARTING: With the edge not pressed, press the Reset button. The 440F contacts close. Press the Start button to energize the 100S safety contactors and start the motor.

STOPPING: Press the Stop button to accomplish a normal production stop. Pressing either edge de-energizes the 440F outputs, and the motor coasts to a stop.

Ratings

Pressing the edge initiates a safety function that has a structure that meets Category 3 and can be used in systems that require Performance Level up to PLd per ISO 13849-1. This circuit executes a Stop Category 0 per IEC 60204-1 and NFPA79.

Figure 41 - Safedge Dual Channel

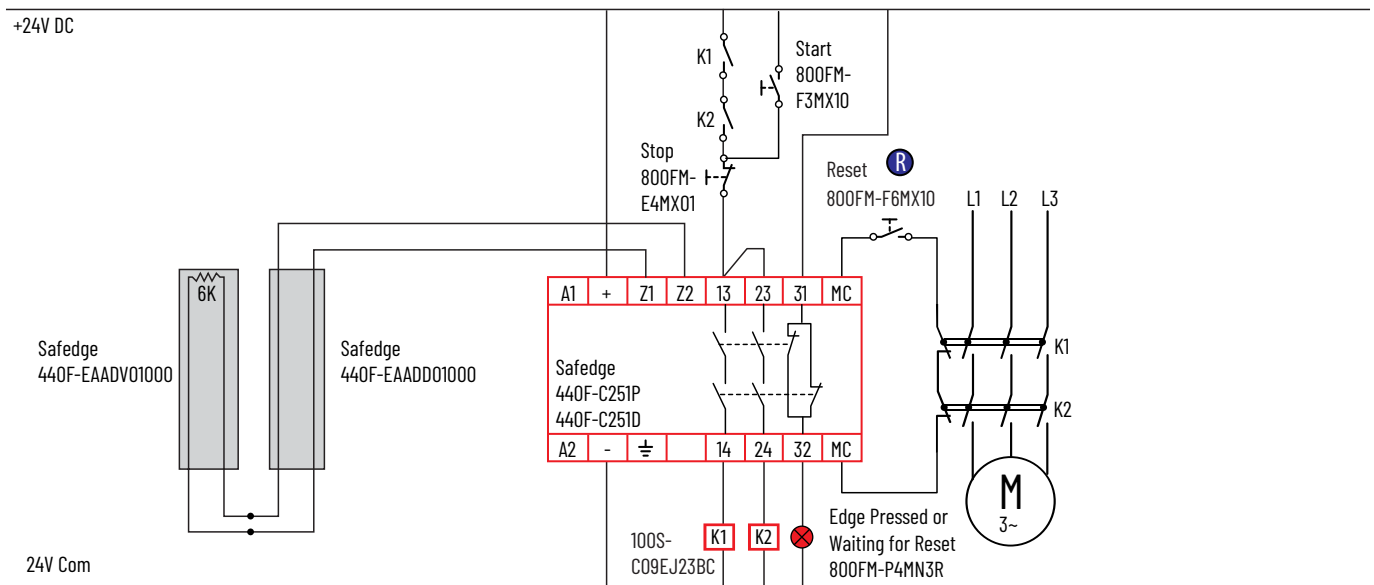

440F-C252D with Safedge Profile

Circuit Components

- 440F safety edge
- 800F push buttons and pilot lights
- 440F safety edge monitoring relay
- 100S safety contactors

Circuit Description

The safety edge relay monitors the safety edges and the series connection of feedback contacts of the 100S safety contactors. In this example, one safety edge is a 2-wire with a 6K terminating resistor and a human hand has depressed the edge. The auxiliary contacts, 31/32, indicate that the edge is pressed.

Circuit Status

The safety edge is pressed. The safety edge relay safety outputs are de-energized, and the 100S safety contactors are OFF. The safety edge relay is waiting for the safety edge to be released.

Operating Principle

STARTING: Remove the hand from compressing the edge. The safety edge relay turns ON its output and enables the circuit to the 100S safety contactors. Press the Start button to energize the 100S safety contactors and start the motor.

STOPPING: Press the Stop button to accomplish a normal production stop. Pressing the safety edge de-energizes the safety edge relay outputs, and the motor coasts to a stop.

Ratings

Pressing the edge initiates a safety function that has a structure that meets Category 2 and can be used in systems that require Performance Level up to PLd per ISO 13849-1. This circuit executes a Stop Category 0 per IEC 60204-1 and NFPA79.

Figure 42 - Safedge Single Channel, Automatic Reset

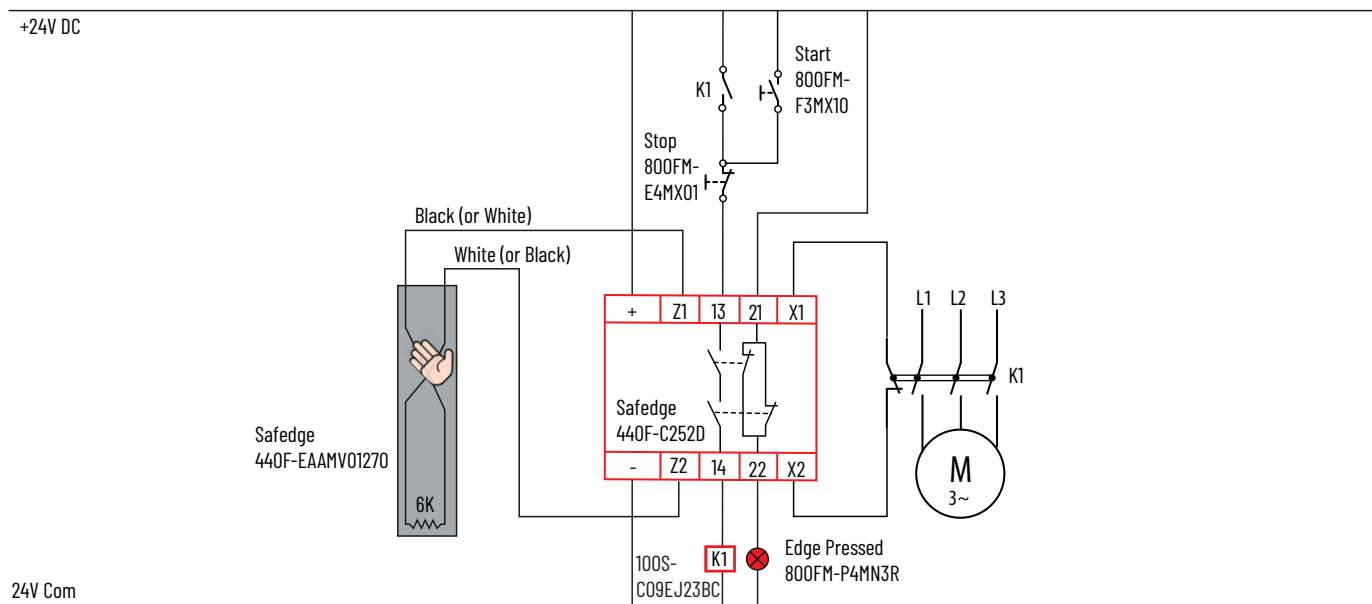

440N-S Sipa 2 Relay with Sipa Sensors

Circuit Components

- 440N N.O. + N.C. diverse inputs
- 800F push buttons and pilot lights
- 440N non-contact safety monitoring relay
- 100S safety contactors

Circuit Description

The Sipa relay monitors sensors that use a diverse structure of inputs; a combination of normally open and normally closed contacts. In this example, multiple Sipa sensors are connected in a series (N.C.)/parallel (N.O.) arrangement. Opening any one of the gates cause the Sipa relay safety outputs to open. All gates must be closed to allow the Sipa relay to energize its safety outputs. The auxiliary contacts, 31/32, indicate that a gate is open or waiting for the Reset button to be pressed.

Circuit Status

The gates are closed. The Sipa 2 relay safety outputs are de-energized, and the 100S safety contactors are OFF. The Sipa 2 relay is waiting for the Reset button to be pressed.

Operating Principle

STARTING: With all gates closed, press the Reset button. The Sipa relay turns ON its safety output and enables the circuit to the 100S safety contactors. Press the Start button to energize the 100S safety contactors and start the motor.

STOPPING: Press the Stop button to accomplish a normal production. Opening any gate de-energizes the Sipa safety outputs, and the motor coasts to a stop.

Ratings

Pressing the edge initiates a safety function that has a structure that meets Category 4 and can be used in systems that require Performance Level up to PLe per ISO 13849-1. This circuit executes a Stop Category 0 per IEC60204-1 and NFPA79.

Figure 43 - Sipa 2 with Series Connection of Sensors

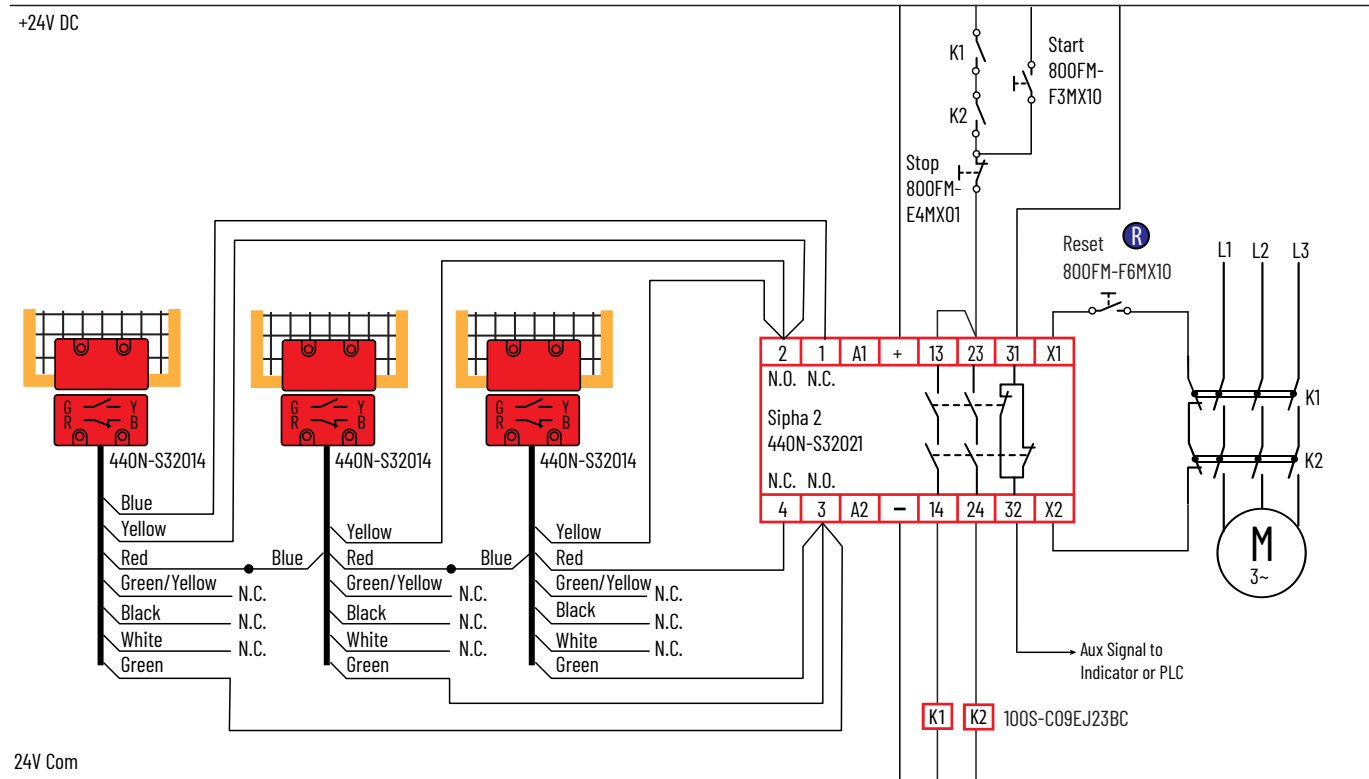

440N-S Sipa 1 with Sipa Sensors

Circuit Components

- 440N N.O. + N.C. diverse inputs
- 800F push buttons
- 440N non-contact safety monitoring relay
- 100S safety contactor

Circuit Description

The Sipa relay monitors sensors that use a diverse structure of inputs; a combination of normally open and normally closed contacts. In this example, multiple Sipa sensors are connected in a series (N.C.)/parallel (N.O.) arrangement. Opening any one of the gates cause the Sipa relay safety outputs to open. All gates must be closed to allow the Sipa relay to energize its safety outputs. The auxiliary contacts, 31/32, indicate that a gate is open or waiting for the Reset button to be pressed.

Circuit Status

One of the gates is open. The Sipa relay safety output is de-energized, and the 100S safety contactor is OFF.

Operating Principle

STARTING: Close the open gate. The Sipa relay turns ON its safety output and enables the circuit to the 100S safety contactor. Press the Start button to energize the 100S safety contactor and start the motor.

STOPPING: Press the Stop button to accomplish a normal production stop. Opening any gate de-energizes the Sipa safety outputs, and the motor coasts to a stop.

Ratings

Pressing the edge initiates a safety function that has a structure that meets Category 2 and can be used in systems that require Performance Level up to PLd per ISO 13849-1. This circuit executes a Stop Category 0 per IEC60204-1 and NFPA79.

Figure 44 - Sipa 1 with Sipa Sensors

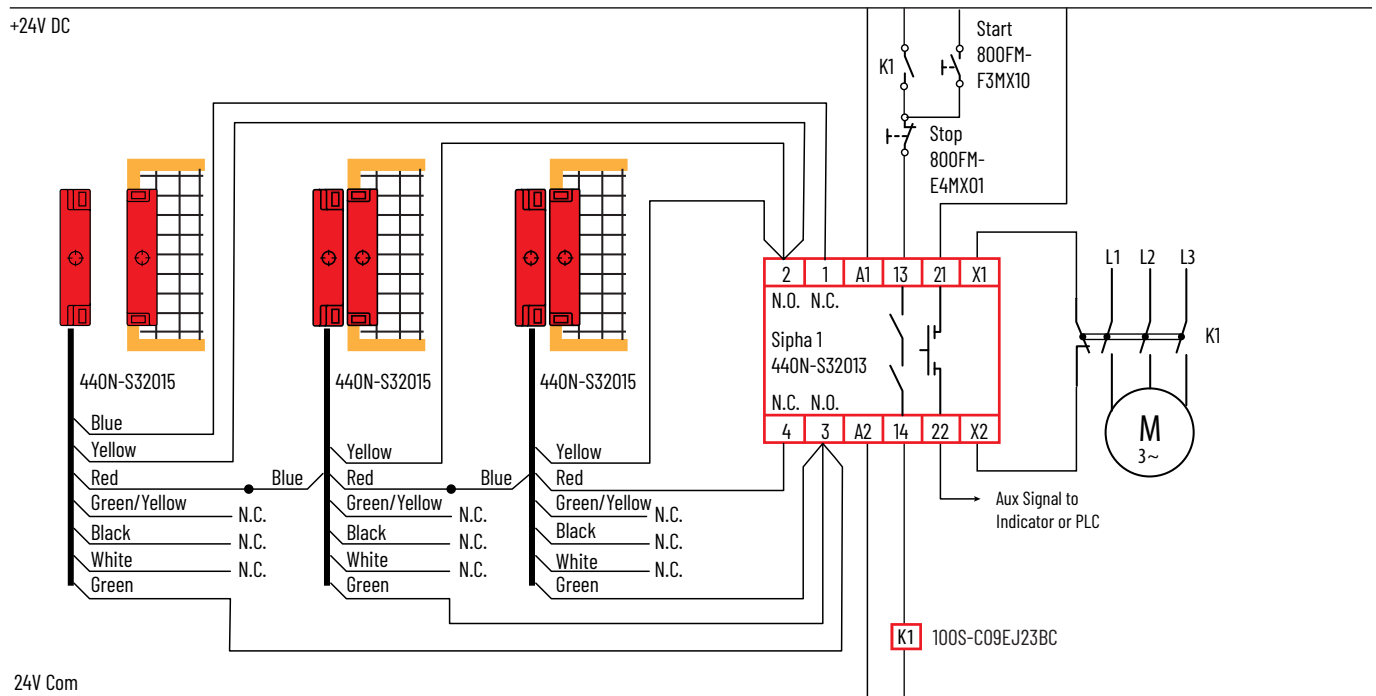

Notes:

Rockwell Automation Support

Use these resources to access support information.

Technical Support Center	Find help with how-to videos, FAQs, chat, user forums, Knowledgebase, and product notification updates.	rok.auto/support
Local Technical Support Phone Numbers	Locate the telephone number for your country.	rok.auto/phonesupport
Technical Documentation Center	Quickly access and download technical specifications, installation instructions, and user manuals.	rok.auto/techdocs
Literature Library	Find installation instructions, manuals, brochures, and technical data publications.	rok.auto/literature
Product Compatibility and Download Center (PCDC)	Download firmware, associated files (such as AOP, EDS, and DTM), and access product release notes.	rok.auto/pcdc

Documentation Feedback





Your comments help us serve your documentation needs better. If you have any suggestions on how to improve our content, complete the form at rok.auto/docfeedback.

Allen-Bradley, Control Tower, expanding human possibility, Ferrogard, Guardmaster, GuardShield, Lifeline, MatGuard, Minotaur, PowerFlex, Prosafe, Rockwell Automation, Safedge, SensaGuard, Sipa, Trojan, and Zero-Force Touch Buttons are trademarks of Rockwell Automation, Inc.

Trademarks not belonging to Rockwell Automation are property of their respective companies.

Rockwell Automation maintains current product environmental compliance information on its website at rok.auto/pec.

Rockwell Otomasyon Ticaret A.Ş. Kar Plaza İş Merkezi E Blok Kat:6 34752, İçerenköy, İstanbul, Tel: +90 (216) 5698400 EEE Yönetmeliğine Uygundur

Connect with us.    

rockwellautomation.com — expanding **human possibility**[®]

AMERICAS: Rockwell Automation, 1201 South Second Street, Milwaukee, WI 53204-2496 USA, Tel: (1) 414.382.2000

EUROPE/MIDDLE EAST/AFRICA: Rockwell Automation NV, Pegasus Park, De Kleetlaan 12a, 1831 Diegem, Belgium, Tel: (32) 2663 0600

ASIA PACIFIC: Rockwell Automation SEA Pte Ltd, 2 Corporation Road, #04-05, Main Lobby, Corporation Place, Singapore 618494, Tel: (65) 6510 6608

UNITED KINGDOM: Rockwell Automation Ltd., Pitfield, Kiln Farm, Milton Keynes, MK11 3DR, United Kingdom, Tel: (44)(1908) 838-800

Publication SAFETY-WD002A-EN-P - January 2025

Copyright © 2025 Rockwell Automation, Inc. All rights reserved. Printed in the U.S.A.