



# M100 Electronic Motor Starters

Bulletins M105, M109



**Allen-Bradley**

by ROCKWELL AUTOMATION

User Manual

Original Instructions

# Important User Information

Read this document and the documents listed in the additional resources section about installation, configuration, and operation of this equipment before you install, configure, operate, or maintain this product. Users are required to familiarize themselves with installation and wiring instructions in addition to requirements of all applicable codes, laws, and standards.

Activities including installation, adjustments, putting into service, use, assembly, disassembly, and maintenance are required to be carried out by suitably trained personnel in accordance with applicable code of practice.

If this equipment is used in a manner not specified by the manufacturer, the protection provided by the equipment may be impaired.

In no event will Rockwell Automation, Inc. be responsible or liable for indirect or consequential damages resulting from the use or application of this equipment.

The examples and diagrams in this manual are included solely for illustrative purposes. Because of the many variables and requirements associated with any particular installation, Rockwell Automation, Inc. cannot assume responsibility or liability for actual use based on the examples and diagrams.

No patent liability is assumed by Rockwell Automation, Inc. with respect to use of information, circuits, equipment, or software described in this manual.

Reproduction of the contents of this manual, in whole or in part, without written permission of Rockwell Automation, Inc., is prohibited.

Throughout this manual, when necessary, we use notes to make you aware of safety considerations.



**WARNING:** Identifies information about practices or circumstances that can cause an explosion in a hazardous environment, which may lead to personal injury or death, property damage, or economic loss.

---



**ATTENTION:** Identifies information about practices or circumstances that can lead to personal injury or death, property damage, or economic loss. Attentions help you identify a hazard, avoid a hazard, and recognize the consequence.

---

**IMPORTANT**

Identifies information that is critical for successful application and understanding of the product.

---

These labels may also be on or inside the equipment to provide specific precautions.



**SHOCK HAZARD:** Labels may be on or inside the equipment, for example, a drive or motor, to alert people that dangerous voltage may be present.

---



**BURN HAZARD:** Labels may be on or inside the equipment, for example, a drive or motor, to alert people that surfaces may reach dangerous temperatures.

---



**ARC FLASH HAZARD:** Labels may be on or inside the equipment, for example, a motor control center, to alert people to potential Arc Flash. Arc Flash will cause severe injury or death. Wear proper Personal Protective Equipment (PPE). Follow ALL Regulatory requirements for safe work practices and for Personal Protective Equipment (PPE).

---

The following icon may appear in the text of this document.



Identifies information that is useful and can help to make a process easier to do or easier to understand.

	<b>Preface</b>	
	About This Publication .....	5
	Terminology.....	5
	Additional Resources .....	7
	<b>Chapter 1</b>	
<b>Overview</b>	Product Description .....	9
	I/O.....	9
	Interface.....	9
	Starter Features .....	10
	Protection Features .....	10
	Catalog Number Explanation.....	10
	Specifications .....	11
	Power-up Tests.....	12
	<b>Chapter 2</b>	
<b>Safe Torque Off Function</b>	Safety Concept .....	13
	Functional Safety Ratings .....	13
	Important Safety Considerations .....	14
	Determining Conformity.....	14
	Functional Testing Instructions .....	15
	Functional Proof Test.....	15
	PFH Data.....	15
	Safety Response Time .....	15
	Safety Inputs Operation.....	15
	Functional Safety SELV/PELV Control Power Input .....	17
	<b>Chapter 3</b>	
<b>Installation</b>	Mount the Starter .....	19
	DIN Rail Mounting .....	20
	Approximate Dimensions.....	21
	Connect Power .....	22
	Connector Location .....	22
	Line and Load Connections .....	23
	Wiring.....	23
	Wire Terminals .....	24
	Wiring Diagrams .....	25
	Three-phase Wiring Diagrams.....	25
	Single-phase Wiring Diagram .....	25
	Control Wiring Diagram .....	27
	Control Power Voltage Source.....	28

<b>Configuration and Operation</b>	<b>Chapter 4</b>	
	Choose Full Load Ampere Setting . . . . .	29
	Choose Single- or Three-phase Power . . . . .	29
	Automatic Reset . . . . .	30
	Auxiliary Output Contactor Status . . . . .	30
	Auxiliary Output Fault Status . . . . .	31
	Control Inputs Operation . . . . .	31
<b>Status Indicators</b>	<b>Chapter 5</b>	
	Motor LED . . . . .	33
	Module LED . . . . .	33
	Trip and Warning IDs . . . . .	33
	Reversing LED . . . . .	33
	Safety LED . . . . .	33
<b>Protection Functions</b>	<b>Chapter 6</b>	
	Reset a Trip . . . . .	35
	Reset Button . . . . .	35
	Remote Reset Control Input . . . . .	35
	Trip Reset . . . . .	36
	Thermal Overload Protection . . . . .	37
	Trip Curves . . . . .	38
	Phase Loss Protection . . . . .	41
	Contact Weld Protection . . . . .	41
	Single-phase Miswiring Protection . . . . .	41
	Phase Imbalance Protection . . . . .	41
<b>Troubleshooting</b>	<b>Chapter 7</b>	
	Introduction . . . . .	43
	Fault and Warning Codes . . . . .	44

## About This Publication

This publication provides information on how to install, program, and use the M100 Electronic Starter.

The user manual assumes that the installer is a qualified person with previous experience and has a basic understanding of electrical terminology, configuration procedures, required equipment, and safety precautions.

For safety of maintenance personnel and others who might be exposed to electrical hazards associated with maintenance activities, follow all local safety-related work practices (such as NFPA 70E, Part II in the United States).

Maintenance personnel must be trained in the safety practices, procedures, and requirements that pertain to their respective job assignments.

## Terminology

Throughout this publication, we refer to the M100 Electronic Starter as the M100 starter. These terms are interchangeable. Where applicable, we refer to the M105 (reversing) and M109 (non-reversing) starters specifically.

[Table 1](#) lists some of the main terms that are used throughout this document.

**Table 1 - List of Common Abbreviations**

<b>Term</b>	<b>Definition</b>
DOL	Direct-on-line
FLA	Full load amperage (full-load current)
HFT	Hardware fault tolerance
LED	Light-emitting diode
N.C.	Normally closed
N.O.	Normally open
OSSD	Output signal switching device
PFH	Average frequency of a dangerous failure
PL	Performance Level
POST	Power-on self-test
PTI	Proof test interval
SCPD	Short-circuit protection device
SIL	Safety integrity level
STO	Safe torque off
TCU	Thermal capacity utilization



**WARNING:** Only personnel familiar with the controller and associated machinery should plan or implement the installation, startup, and subsequent maintenance of the system. Failure to do so can result in personal injury and/or equipment damage.

**WARNING:** To avoid shock hazard, disconnect the main power before working on the controller, motor, and control devices such as Start-Stop push buttons. Procedures that require parts of the equipment to be energized during troubleshooting, testing, and so on, must be performed by properly qualified personnel, using appropriate local safety work practices and precautionary measures.

**WARNING:** The device can restart automatically after a trip. Take precautions to avoid injury.

---



**AVERTISSEMENT:** Seul le personnel familiarisé avec le démarreur et les mécanismes associés doit planifier ou réaliser l'installation, la mise en route et la maintenance consécutive du système. Le non-respect de ces recommandations peut entraîner des blessures ou des dommages matériels.

**AVERTISSEMENT:** Pour éviter les chocs électriques, coupez l'alimentation principale avant d'intervenir sur le démarreur, sur le moteur et sur les équipements de commande tels que les boutons-poussoirs Marche/Arrêt. Les procédures qui nécessitent une alimentation partielle de l'équipement pendant le dépannage, les tests, etc., doivent être effectuées par du personnel dûment qualifié, en appliquant les pratiques de sécurité au travail et les mesures de précaution locales.

**AVERTISSEMENT:** Le dispositif peut redémarrer automatiquement après un déclenchement. Veuillez prendre des précautions pour prévenir les risques.

---



**ATTENTION:** The controller must be correctly applied and installed. If applied or installed incorrectly, damage to the components or the reduction in product life may occur.

**ATTENTION:** The system may malfunction if the following wiring or application errors occur: undersizing the motor, using an improperly sized controller, using an incorrect or inadequate AC supply, excessive ambient temperatures, or power quality.

**ATTENTION:** You must program the Motor Current adjustment dial to provide proper protection.

**ATTENTION:** Overload configuration must be properly coordinated with the motor.

**ATTENTION:** This product has been designed and tested as Class A equipment for electromagnetic compatibility (EMC). Use of this product in domestic environments may cause radio interference, in which case, the installer may need to employ additional mitigation methods.

**ATTENTION:** Static control precautions are required when you install, test, service, or repair the assembly. The controller contains electrostatic discharge (ESD) sensitive parts and assemblies. Component damage may result if ESD control procedures are not followed. If you are not familiar with static control procedures, See applicable ESD protection handbooks.

**ATTENTION:** After a short circuit occurs, you must verify device functionality.

---

## Additional Resources

These documents contain additional information concerning related products from Rockwell Automation. You can view or download publications at [rok.auto/literature](http://rok.auto/literature).

Resource	Description
Installation Instruction for Motor Starters, publication <a href="#">M100-IN001</a>	This publication provides information on how to install the M100 Electronic Starter.
Electronic Motor Starters Technical Data, publication <a href="#">M100-TD001</a>	Provides product selection and specification information for the Bulletin M100 line of starters and safety starters.
Motor Protection Circuit Breaker and Motor Circuit Protector Specifications, publication <a href="#">140-TD005</a>	Provides product selection and specification information for the Bulletin 140MP and 140MT lines of motor protection devices.
Short-circuit Current Ratings and Your Industrial Control Panel, publication <a href="#">SCCR-AT002</a>	Provides examples for short-circuit current ratings of panels that are based on the methods that are stated in UL 508A Supplement B.
EtherNet/IP™ Network Devices User Manual, publication <a href="#">ENET-UM006</a>	Describes how to configure and use EtherNet/IP devices to communicate on the EtherNet/IP network.
Ethernet Reference Manual, publication <a href="#">ENET-RM002</a>	Describes basic Ethernet concepts, infrastructure components, and infrastructure features.
American Standards, Configurations, and Ratings: Introduction to Motor Circuit Design, publication <a href="#">IC-AT001</a>	Provides an overview of American motor circuit design based on methods that are outlined in the NEC.
Industrial Components Preventive Maintenance, Enclosures, and Contact Ratings Specifications, publication <a href="#">IC-TD002</a>	Provides a quick reference tool for Allen-Bradley® industrial automation controls and assemblies.
Industrial Automation Wiring and Grounding Guidelines, publication <a href="#">1770-4.1</a>	Provides general guidelines for installing a Rockwell Automation industrial system.
Product Selection and Configuration tools, <a href="http://rok.auto/systemtools">rok.auto/systemtools</a>	Helps configure complete, valid catalog numbers and build complete quotes based on detailed product information.
Rockwell Automation Global SCCR tool, <a href="http://rok.auto/sccr">rok.auto/sccr</a>	Provides coordinated high-fault branch circuit solutions for motor starters, soft starters, and component drives.
Product Certifications website, <a href="http://rok.auto/certifications">rok.auto/certifications</a>	Provides declarations of conformity, certificates, and other certification details.

**Notes:**



## Overview

### Product Description

The M100 starter is an advanced electro-mechanical motor starter that combines the functionality of a contactor and an overload relay into a smaller footprint. This starter series offers direct-on-line (DOL) and reversing electronic motor starters, with an option for SIL 3 Safe Torque Off (STO) Functional Safety.

These three-pole starters can control both single- and three-phase motors up to 480V AC and are available with maximum current ratings of 9 A and 23 A. The M100 starter has integrated electronic overload protection, which eliminates the need for a separate overload relay.

The M100 series of starters includes non-reversing, reversing, safety, and standard options, all of which have the same slim form-factor. All M100 starter options can be installed side-by-side without derating. This configuration is referred to as 'zero stacked.' Zero-stacking significantly reduces required panel space.

For a list of compatible short circuit protection devices (SCPDs), see the M100 Starter Specifications Technical Data, publication [M100-TD001](#).

### I/O

The M100 starter requires a 24V DC control power source for control power and uses 24V DC control signals. For control inputs, the M100 starter is equipped with start, stop, remote reset, and reversing (when applicable).

Two separate, integrated 24V DC (100 mA max load) outputs signal the M100 starter and fault status. The M100 starter safety option requires two separate 24V DC OSSD safety demands, which must be provided from a compatible safety logic device.

### Interface

The M100 starter features a user interface on the front of the unit for configuration and diagnostics. Light-emitting diodes (LEDs) indicate module and motor status and reversing and STO status when applicable. With the M100 starter DIP switches, you can switch between single- and three-phase control and select auto or manual overload reset. A full load ampere (FLA) selector dial is also installed on the front of the unit, which can be used to configure the M100 starter protection features.

## Starter Features

Figure 1 - M100 Starter Features

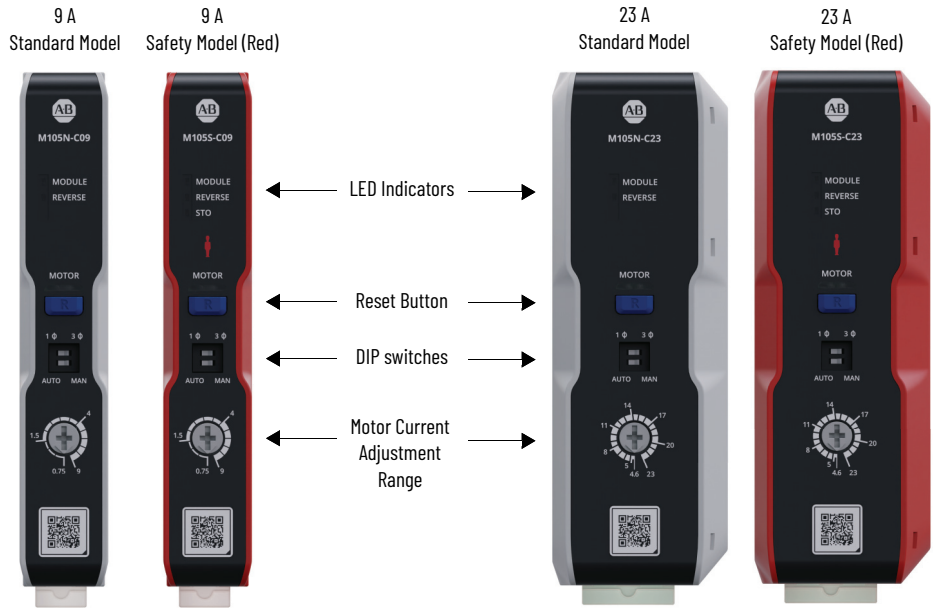

For M100 starter terminal block information, see [Figure 7](#).

## Protection Features

The M100 starter offers multiple protection functions with the following options:

- Thermal overload protection with Class 10 overload trip
- Auto and manual overload reset
- Phase loss protection
- Phase imbalance protection
- Contact weld protection
- Single-phase miswiring protection
- Remote reset control input

## Catalog Number Explanation

The examples that are provided in this section are not intended to be used for product selection. Not all combinations produce a valid catalog number. Use ProposalWorks™ software to configure the M100 starter. ProposalWorks software is available from [rok.auto/systemtools](http://rok.auto/systemtools).

M105
S
-
C09
-
S

a
b
c
d

a	
Bulletin Number	
Code	Description
M105	M100 reversing starter
M109	M100 non-reversing starter

b	
Safety	
Code	Description
N	No functional safety
S	Functional safety

c	
Current Range	
Code	Description
C09	0.75...9 A
C23	4.6...23 A

d	
Terminals	
Code	Description
S	Screw terminals
P	Push-in terminals

For a list of available accessories, see the M100 Starter Specifications Technical Data, publication [M100-TD001](#).

# Specifications

**Table 2 - General Ratings**

Attribute		Value
Standards compliance		<ul style="list-style-type: none"> <li>UL 60947-4-1</li> <li>CSA C22.2, No. 60947-4-1</li> <li>EN 60947-4-1</li> <li>NM EN 60947-4-1</li> </ul> For more information, see <a href="#">Table 4</a>
Certifications		<ul style="list-style-type: none"> <li>cULus, CE, UKCA, Morocco, RCM</li> </ul> For more information, see <a href="#">Table 4</a> For additional product certifications currently available from Rockwell Automation, see <a href="http://rok.auto/certifications">rok.auto/certifications</a>
Rated operating current	9 A configuration	0.75...9 A
	23 A configuration	4.6...23 A
Rated operating voltage $U_e$		480V AC
Maximum operating voltage		480V AC
Rated insulation voltage $U_i$		500V
Rated impulse withstand voltage $U_{imp}$		6 kV
Rated frequency		50/60 Hz
Trip Class		10
Utilization Category		AC-3
Number of operations		1,000,000 (AC-3)
Temperature	Storage temperature range	-40...+85 °C (-40...+185 °F)
	Ambient temperature range	-20...+55 °C (-4...+131 °F)
	Surrounding air temperature range	-20...+65 °C (-4...+149 °F)
Humidity	Operating	5...95% noncondensing 92% relative humidity
	Damp Heat - Steady State Per IEC 60068-2-78	93% relative humidity 40 °C (104 °F) 56 days
	Damp Heat - Cyclic Per IEC 60068-2-30	93% relative humidity 25 °C/40 °C (77 °F/104 °F) 21 Cycles
Cooling Method		Natural convection
Resistance to Vibration Per IEC 60068-2-6	9 A configuration	Operating 3 G
	23 A configuration	
Resistance to Shock Per IEC 60068-2-27	9 A configuration	15 G Operating 30 G Nonoperating
	23 A configuration	15 G Operating 25 G Nonoperating
Maximum Altitude		2000 m (6561 ft)
Pollution Environment		Pollution Degree 3
Mounting		Vertical Mounting Recommended See <a href="#">Chapter 3</a>
Minimum distance to other units, same type		Zero-stack capability
Degree of protection		IP20 with terminal blocks installed
Minimum enclosure size	9 A configuration	406 x 305 x 203 mm (16 x 12 x 8 in.)
	23 A configuration	

Table 3 - Fault Ratings

Rating	Protection Type	Attribute	9 A Starters	23 A Starters
UL Standard Fault	Fuse or circuit breaker	Max Fuse [A]	35 (Class RK5)	90 (Class J)
		Max Circuit Breaker [A]	30 (Bulletin 140UT)	
		Standard Fault Current [kA]	1	3
UL High Fault	Fuse	Max Class J Fuse [A]	35	60
		Max Class CC Fuse [A]	30	–
		High Fault Current [kA]	100	
	Circuit breaker	Max Circuit Breaker [A]	30	
		High Fault Current [kA]	65	
		Recommended Circuit Breaker (480Y/277V)	Cat. No. 140UT-D7D3-C30	



Devices rated for 9 A (M105N/S-C09-..., M109N/S-C09-...) are Suitable for motor group applications when used on the load side of a cat. no. 140MT-D9E-C20 with an SCCR rating of 65 kA @ 480Y/277V.

## Power-up Tests

The M100 starter performs a power-on self-test (POST) at system startup. If the POST detects any hardware faults that are related to critical and noncritical errors, it reports the faults at system startup. The module status light-emitting diode (LED) indicates any critical error hardware faults discovered during the POST.

A critical error is defined as an issue that could result in indeterminate device operation – for example, non-volatile memory or RAM corruption.

### IMPORTANT

If the system detects any critical errors during the POST, essential functions performed by the M100 starter must be stopped until the errors are resolved.

## Safe Torque Off Function

### Safety Concept

The TÜV Rheinland group has approved the M100 starter for use in safety applications up to and including the following:

- Category 3 according to EN ISO 13849-1
- SIL 3 according to IEC 61508

As a risk reduction method, the M100 starter STO can be used together with other components in a safety application to achieve the following:

- An overall Category 3 / PL(e) according to EN ISO 13849-1
- SIL 3 according to EN 62061 and IEC 61508

---

**IMPORTANT** The following safety requirements are based on the standards that are current at the time of certification.

---

For product certifications currently available from Rockwell Automation, see [rok.auto/certifications](http://rok.auto/certifications).

### Functional Safety Ratings

The M100 starter series models conform to the following functional safety standards.

**Table 4 - Functional Safety Ratings**

Attribute		Rating
Safety integrity level (SIL) of 3		IEC 61508
Designated architecture Category 3		(EN) ISO 13849-1 Standard
Suitable for use in SIL 3		IEC/EN 62061 Standard
Suitable for use in Performance Level e (PLe)		(EN) ISO 13849-1 Standard
PFH	9 A Devices	5.31E-09
	23 A Devices	4.04E-09
HFT		1 (1oo2)
PTI		20 years
Hardware Type		Type A
Safety demand validation interval		1 month
M100 starter control power source		<ul style="list-style-type: none"> <li>• 24V DC SELV/PELV</li> <li>• Fault Voltage = 60V</li> <li>• Connected to the M100 starter A1+ and A2-terminals</li> <li>• Conforms to the SELV/PELV requirements of IEC 60364-4-41</li> <li>• 60V maximum, including ripple, isolation, and noise</li> </ul>
Mounting		Inside an enclosure rated to a minimum of IP54
Mode of Operation		High Demand

For product certifications currently available from Rockwell Automation, see [rok.auto/certifications](http://rok.auto/certifications).

## Important Safety Considerations

The M100 starter operator is responsible for the following:

- Setup, safety rating, and validation of any sensors or actuators connected to the system
- Completion of a system-level risk assessment and reassessment of the system when a change is made
- Certification of the system to the desired safety Performance Level
- Project management and proof testing, including compliance with ISO 13849-1
- Access control of the system
- Validation of any sensors or actuators that are connected to the system
- Completion of a machine-level risk assessment
- Certification of the machine to the desired ISO 13849-1 Performance Level or EN/IEC 62061 SIL level

---

**IMPORTANT** When you engage a functional safety test, restrict system access to qualified and authorized personnel who are properly trained and experienced.

---



**ATTENTION:** When you design your system, consider how personnel can exit the machine, in case the door locks while personnel are in the machine.  
**ATTENTION:** Additional safeguard devices may be required for your specific application.

---

## Determining Conformity

When determining the conformity of your system design, note the following.

---

**IMPORTANT** The M100 starter operator is responsible for determining conformity to the applicable standards and confirming the suitability of the devices that are used in the application of the system.

---

Components in the system must be chosen and applied appropriately to achieve the desired level of operator safeguarding.



**ATTENTION:** Use only the appropriate components or devices that comply with the relevant safety standards, and meet the required safety integrity level or Performance Level and safety category.  
**ATTENTION:** To determine the requirement conformity of the relevant safety standards for the entire system, you must conduct a risk assessment.  
**ATTENTION:** Use the system devices properly and in accordance with the installation environment, performance rating, and functions of the machine.  
**ATTENTION:** Use the system devices within their specified ratings.  
**ATTENTION:** We recommend that you consult a certification body regarding assessment of conformity to the required safety integrity level or Performance Level.

---

## Functional Testing Instructions

A manual functional electric test must be made:

- After installation
- After any maintenance or change of component
- If the safety demand is used less than once per month



**WARNING:** During the functional test, confirm that there are no persons in the danger area and that the machine startup does not cause any hazards.



**AVERTISSEMENT:** Durant le test fonctionnel, vérifier que personne ne se tient dans la zone de danger et que le démarrage de la machine n'entraîne aucun risque.

To perform a functional test:

1. Apply a start command to the M100 starter and confirm that the connected motor is running.
2. Create a safety demand on M100 starter Input Terminals S12 and S22 and confirm that the motor connected to the M100 starter stops.
3. Remove the safety demand on M100 starter Input Terminals S12 and S22.
4. Remove and reapply both the stop and start commands to the M100 starter.
5. Confirm the connected motor restarts.

For fault code and troubleshooting information, see [Chapter 7](#).

## Functional Proof Test

The values that are provided in the [Functional Safety Ratings](#) section are contingent upon the Proof Test Interval (PTI).

## PFH Data

The average frequency of a dangerous failure (PFH) is based on the equations from Part 6 of EN 61508. See [Table 4](#) for 20-year proof test interval data and worst-case scenario effects of various configuration changes to the data.

## Safety Response Time

The safety response time is the amount of time that has elapsed from when the system receives a safety-related event, until the system returns to a safe state.

The system safety response time is 100 ms (maximum). Safety response time is defined as the time that has elapsed when one or both input safety signals become invalid (de-energized), and the M100 starter is switched to the safe state.

## Safety Inputs Operation

The M100 starter functional safety configuration has two safety demand inputs:

- S12
- S22

These safety inputs are 24V DC ( $U_e$ ) type 1 rated inputs, as defined in EN 60947-1.

For wiring diagram information, see [Wiring Diagrams](#).

The M100 starter has the following safety inputs, types, and compatibility.

**Table 5 - Safety Inputs Operation**

Input	Compatibility
Safety rated	<ul style="list-style-type: none"> <li>Compatible with pulsed 24V signal outputs by an OSSD device</li> <li>Reject low OSSD pulses up to 1 ms</li> </ul>
	<ul style="list-style-type: none"> <li>The system has 2 hard-wired safety inputs</li> <li>Inputs originate from an external device that sends signals in OSSD format</li> <li>To maintain a SIL 3 rating, the safety input devices must be rated SIL 3 OSSD</li> <li>Safety channel mismatch discrepancy time up to 25 ms</li> </ul>

The M100 starter has a safety input for an output signal switching device (OSSD) type. See [Table 6](#).



0 refers to state 0 (0V DC) and 1 refers to state 1 (24V DC), as defined in EN60947-1.

**Table 6 - Safety Inputs**

S12	S22	Action
0	0	Safety demand
0	1	Safety demand
1	0	Safety demand
1	1	No safety demand

Under normal operation, both safety inputs (Safety 1 and Safety 2) are energized and the system is able to run. If either input is de-energized, the device enters the safe state.

The M100 starter has the following three-wire control functional safety operating modes.

**Figure 2 - Functional Safety Operation Modes for Three-wire Configurations**

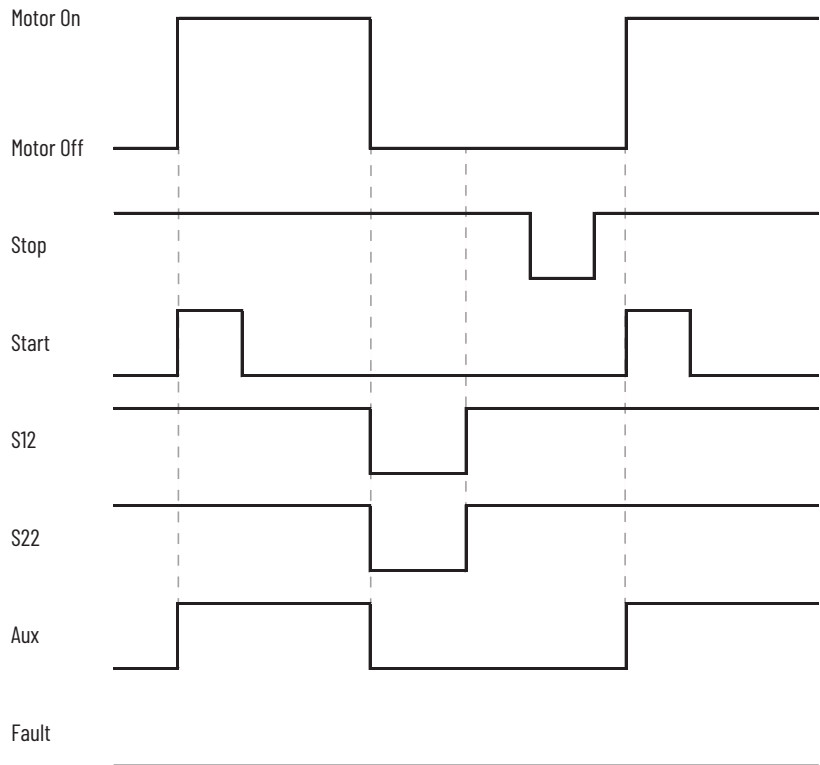



The M100 starter has the following two-wire control functional safety operating modes.

**Figure 3 - Functional Safety Operation Modes for Two-wire Configurations**

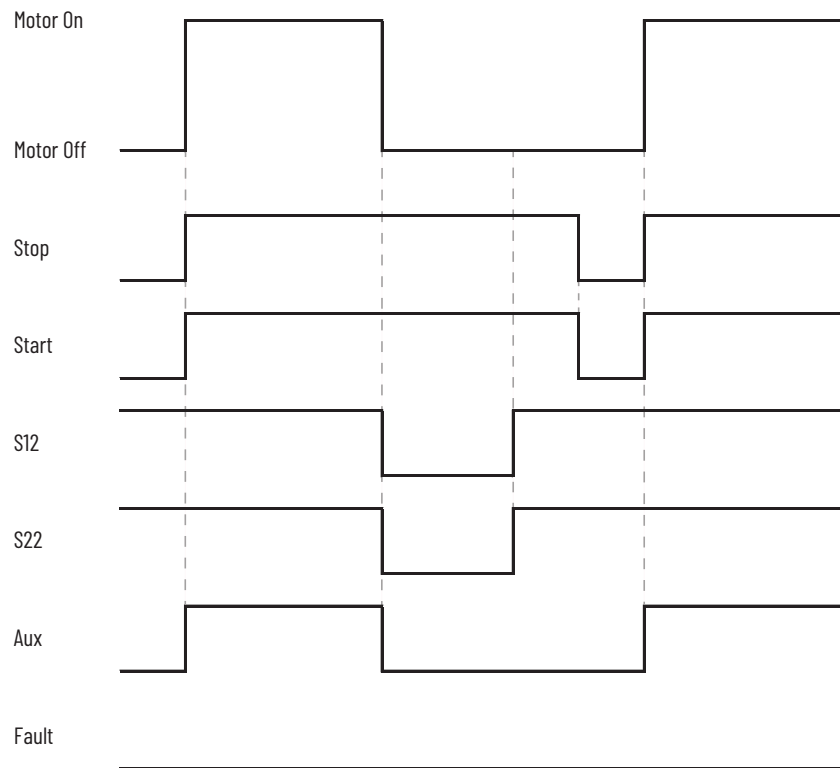

## Functional Safety SELV/ PELV Control Power Input

The functional safety version of the M100 starter has the following features:

- The M100 starter is powered with a 24V DC SELV/PELV control power source, which is connected to the M100 starter A1+ and A2- terminals.
- The control power source conforms to the SELV/PELV requirements of IEC 60364-4-41.
- The control power source fault voltage is limited to 60V maximum.
- The 60V maximum limit includes ripple, isolation, and noise.

**Notes:**

## Installation

To install the M100 starter, follow the steps in this section.

### Mount the Starter

The M100 starter can be mounted vertically in a zero-stacked configuration at maximum current without derating.

Figure 4 - Vertical Mounting

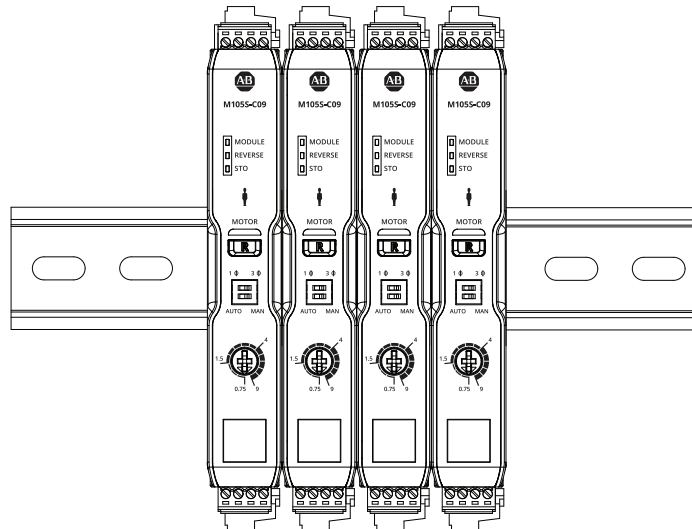

Although the M100 starter is designed to be mounted in a vertical orientation, it operates correctly when mounted horizontally.

Figure 5 - Horizontal Mounting

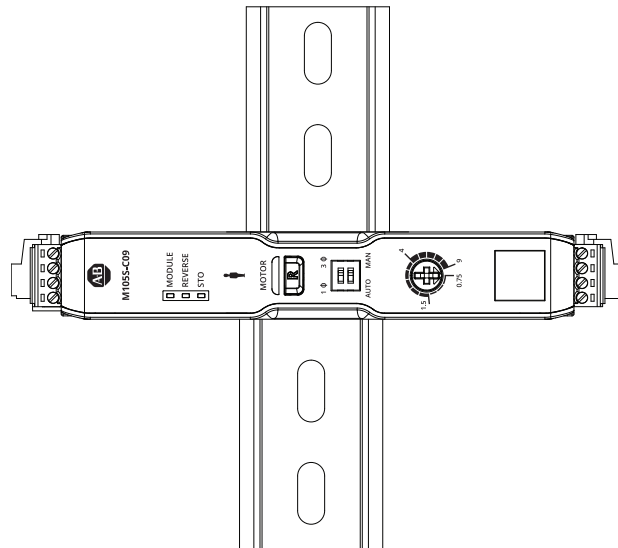

**IMPORTANT** If the M100 starter is mounted horizontally, do not mount additional M100 starter units in the space above or below the unit.

## DIN Rail Mounting

The M100 starter uses standard 35 x 7.5 mm (1.38 x 0.30 in.) DIN Rail mounting.

To install the M100 starter on a DIN Rail, perform the following steps.

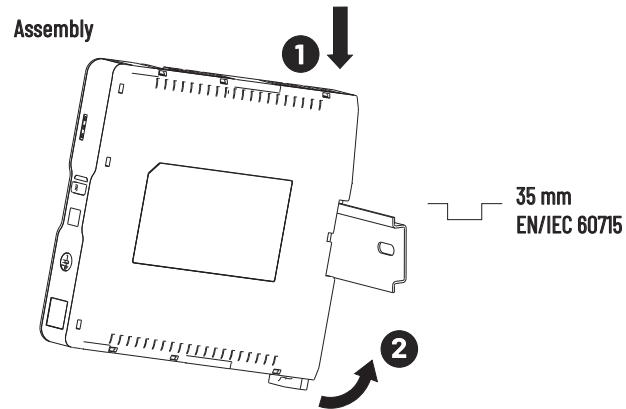

To remove the M100 starter from a DIN Rail, perform the following steps.

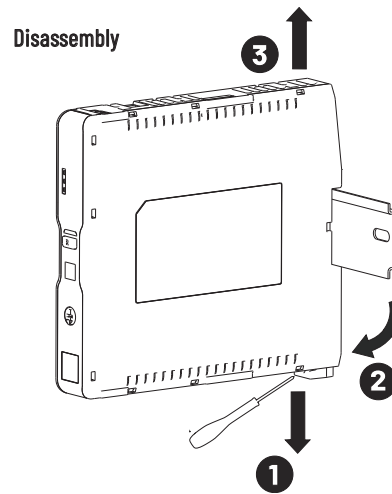

When mounted on a DIN Rail in vertical orientation, the M100 starter provides top-feed power line and bottom-feed motor load terminations.

For additional information on mounting the M100 starter on DIN Rail, see the M100 Motor Starters Installation Instructions, publication [M100-IN001](#).

## Approximate Dimensions

Dimensions are in millimeters (inches). Dimensions are not intended to be used for manufacturing purposes.

**Figure 6 - Approximate Dimensions**

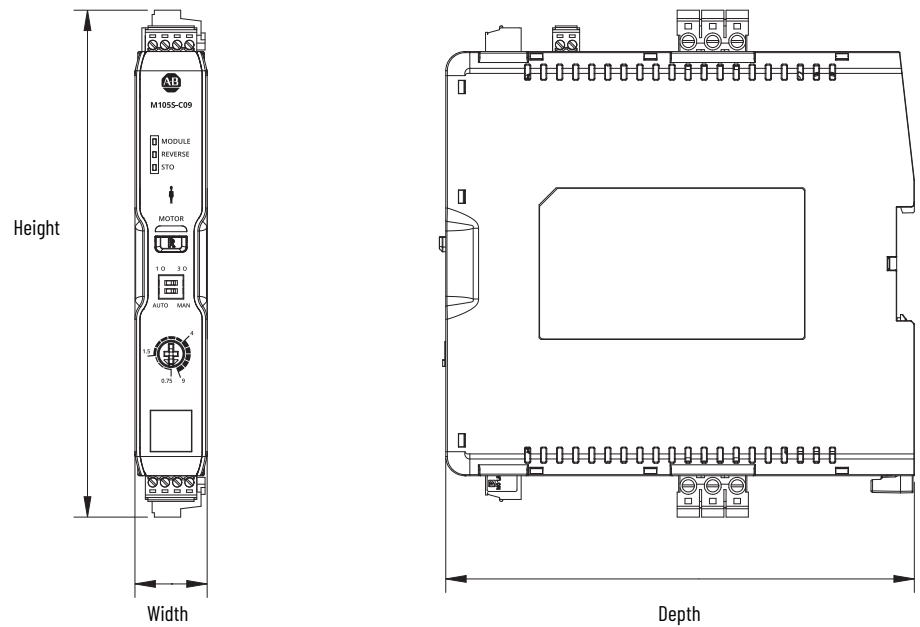

**Table 7 - Approximate Dimensions**

Starter Size	Height [mm (in.)]	Width [mm (in.)]	Depth [mm (in.)]
9 A	158.1 (6.22)	22.5 (0.89)	148 (5.83)
23 A	180.6 (7.11)	45 (1.77)	168.7 (6.64)

# Connect Power

## Connector Location

The M100 starter has the following connectors.

Figure 7 - Connectors

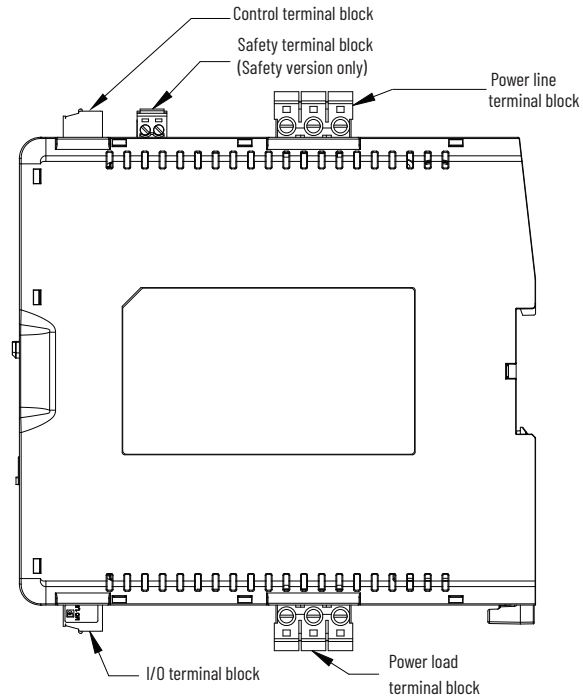

To connect power to the M100 starter, perform the following steps.

Figure 8 - Power Connector Installation

### Wiring Connection

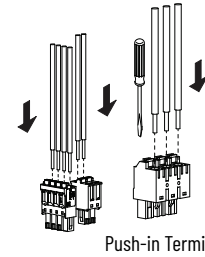
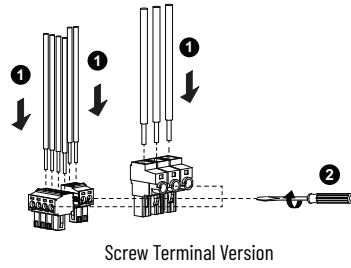

See [Table 8](#) for recommended wiring installation tool

### Terminal Block Installation

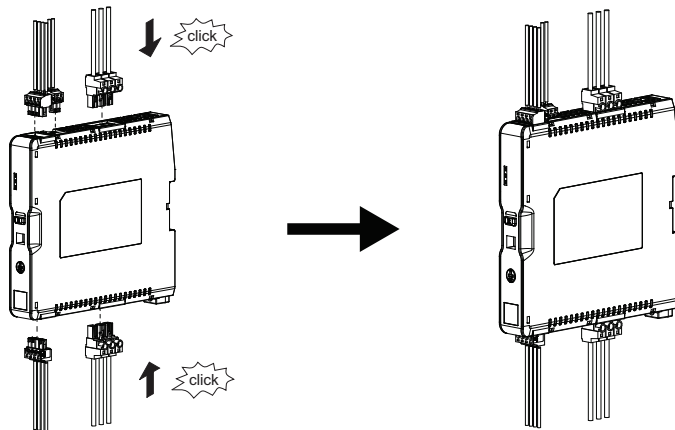

## Line and Load Connections

Connect line and load wiring to the device in a three-phase configuration.

To maintain short-circuit performance while using the device in a three-phase configuration, secure the cables as shown in [Figure 9](#).

The M100 starter terminal main line and load connections support the following:

- Flexible stranded wire
- Flexible stranded wire with ferrule
- Coarse-stranded wire
- Solid wire



Only one single conductor can be used on the power and safety terminals. The control/aux terminal can use two conductors per terminal.

## Wiring

Use the information in [Figure 9](#) and [Table 8](#) to properly wire and secure the M100 starter. Attach a cable tie securely every 5 cm (2 in.) along the length of the power cables, starting at the power plug and ending at the wireway.



**ATTENTION:** For UL certification, the wire ties are required to achieve the maximum short circuit rating.

**Figure 9 - Secure the Power Cables**

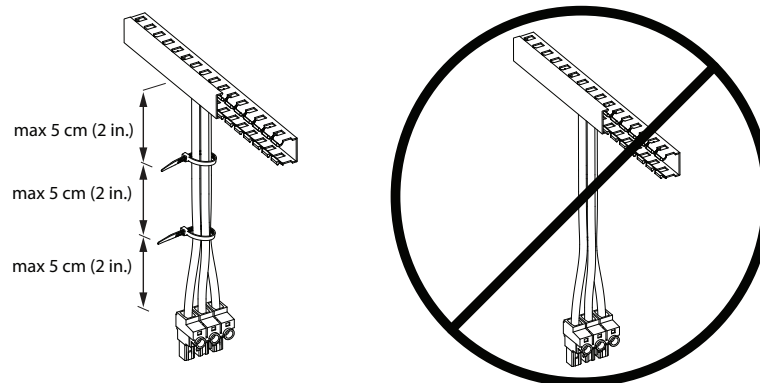



Table 8 - Wiring and Torque Specifications

Connection				Screw Terminals						Push-in Terminals							
				Power Terminals <sup>(1)</sup>		Control/Auxiliary Terminals		Safety Terminals		Power Terminals <sup>(1)</sup>		Control/Auxiliary Terminals		Safety Terminals			
				9 A	23 A	9 A	23 A	9 A	23 A	9 A	23 A	9 A	23 A	9 A	23 A		
Wiring	Solid		1 conductor	mm <sup>2</sup>	2.5...4	2.5...6	1...2.5		0.5...1.5		2.5...4	2.5...6	1...2.5		0.5...1.5		
			AWG	14...12	14...10	18...14		28...16		14...12	14...10	18...14		28...16			
		2 conductors	mm <sup>2</sup>	—	—	1...1.5		—	—	—	—	1...2.5		—	—		
		AWG	—	—	18...16		—	—	—	—	18...16		—	—			
	Stranded <sup>(2)</sup>		1 conductor	mm <sup>2</sup>	2.5...4	2.5...6	1...2.5		0.5...1.5		2.5...4	2.5...6	1...2.5		0.5...1.5		
			AWG	14...12	14...10	18...14		28...16		14...12	14...10	18...14		28...16			
		2 conductors	mm <sup>2</sup>	—	—	1...1.5		—	—	—	—	1...1.5		—	—		
		AWG	—	—	18...16		—	—	—	—	18...16		—	—			
Stripping length				9 mm (0.35 in.)		9 mm (0.35 in.)		9 mm (0.35 in.)		9 mm (0.35 in.)		9 mm (0.35 in.)		9 mm (0.35 in.)			
Recommended screwdriver				3 mm (1/8 in.)		3 mm (1/8 in.)		3 mm (1/8 in.)		Push button	0.6 x 3.5 mm (0.02 x 0.14 in.)	0.4 x 2.5 mm (0.02 x 0.1 in.)		0.4 x 2.5 mm (0.02 x 0.1 in.)			
Tightening torque				N•m		0.4...0.5		0.5...0.6		0.22...0.25		0.22...0.25		—			
				lb•in		3.5...4.4		4.4...5.3		1.95...2.21		1.95...2.21					

(1) Power terminals allow only one conductor per terminal (line and load sides).  
 (2) Main line and load connections support flexible stranded wire, flexible stranded wire with ferrule, or coarse-stranded wire.

For more information on wiring terminal installation and specifications, see the Installation Instruction for Motor Starters, publication [M100-IN001](#).

### Wire Terminals

The M100 starter series terminals require the use of standard nomenclature for terminal designations, as follows.

Table 9 - Terminal Designations

Terminal	M109N Standard Non-reversing	M105N Standard Reversing	M109S Safety Non-reversing	M105S Safety Reversing
1/L1	Line phase 1		Line phase 1	
3/L2	Line phase 2		Line phase 2	
5/L3	Line phase 3		Line phase 3	
2/T1	Load phase 1		Load phase 1	
4/T2	Load phase 2		Load phase 2	
6/T3	Load phase 3		Load phase 3	
A1+	24V DC control power source positive		24V DC control power source positive	
A2-	24V DC control power source common		24V DC control power source common	
IN1	24V DC control input (start)		24V DC control input (start)	
IN2	24V DC control input (stop)		24V DC control input (stop)	
REV	—	24V DC control input – positive (reverse)	—	24V DC control input – positive (reverse)
O-1	Auxiliary output contactor status – 24V DC, 100 mA maximum		Auxiliary output contactor status – 24V DC, 100 mA maximum	
O-2	Auxiliary output fault status – 24V DC, 100 mA maximum		Auxiliary output fault status – 24V DC, 100 mA maximum	
RES	24V DC input – remote reset		24V DC input – remote reset	
S12	—	—	24V DC safety demand 1 (OSSD)	
S22	—	—	24V DC safety demand 2 (OSSD)	



## Wiring Diagrams

### Three-phase Wiring Diagrams

The M100 starter has the following three-phase configuration.

Figure 10 - Three-phase Wiring

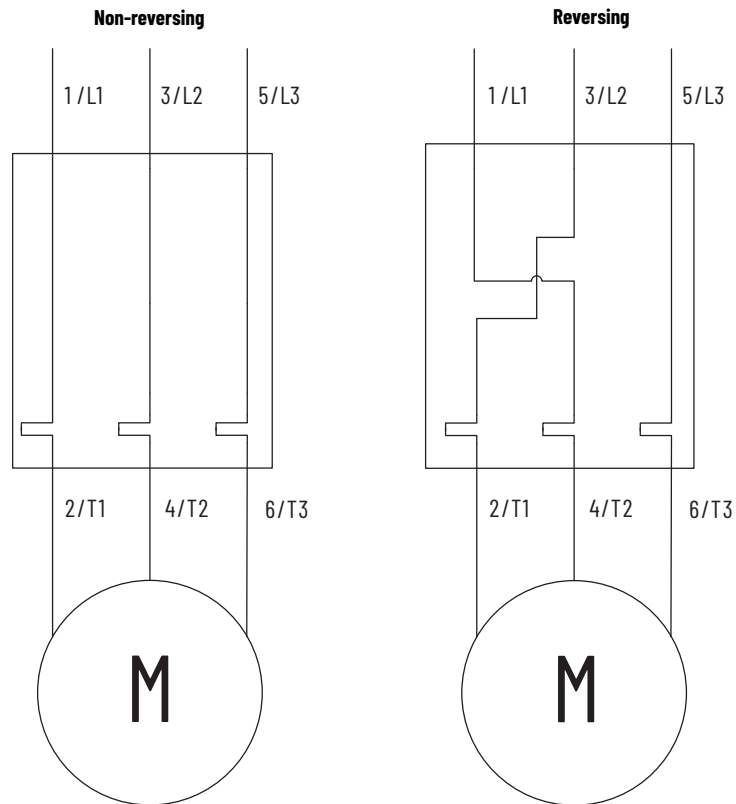

Table 10 - Line and Load Connections

Starter Type	Motor Direction	Description	Connections
Non-reversing <sup>(1)</sup>	Forward	When a valid start command is sent to the system, all non-reversing configurations of the M100 starter connect.	<ul style="list-style-type: none"> <li>• L1 to T1</li> <li>• L2 to T2</li> <li>• L3 to T3</li> </ul>
Reversing	Forward <sup>(1)</sup>	When a valid start forward direction command is sent to the system, all reversing configurations of the M100 starter connect.	<ul style="list-style-type: none"> <li>• L1 to T2</li> <li>• L2 to T1</li> <li>• L3 to T3</li> </ul>
Reversing	Reverse <sup>(1)</sup>	When a valid start reverse direction command is sent to the system, all reversing configurations of the M100 starter connect.	<ul style="list-style-type: none"> <li>• L1 to T2</li> <li>• L2 to T1</li> <li>• L3 to T3</li> </ul>

(1) This requirement applies to three-phase configurations.

### Single-phase Wiring Diagram

The M100 starter has the following single-phase configuration.

When configured in single-phase mode, the device must only be wired to the line and load as follows:

- Line – wiring on terminals L1 and L3 only
- Load – wiring on terminals T1 and T3 only

Any other connection that is installed on the line or load side causes the M100 starter to generate a single-phase miswire fault.

Figure 11 - Single-phase Wiring

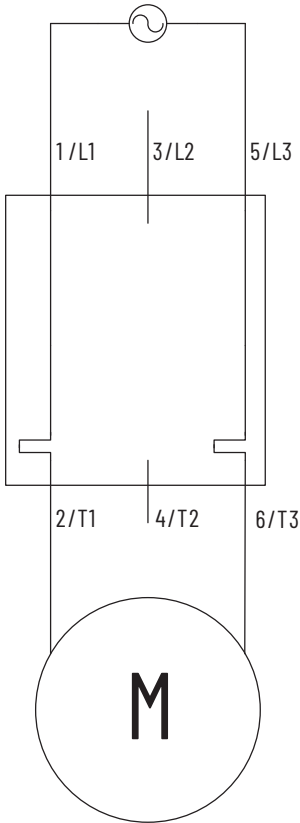

### Control Wiring Diagram

Figure 12 shows the correct wiring to configure the M100 starter for three-wire control.

**Figure 12 - Three-wire Control with OSSD Functional Safety Devices – Remote Reset, Reversing, Auxiliary**

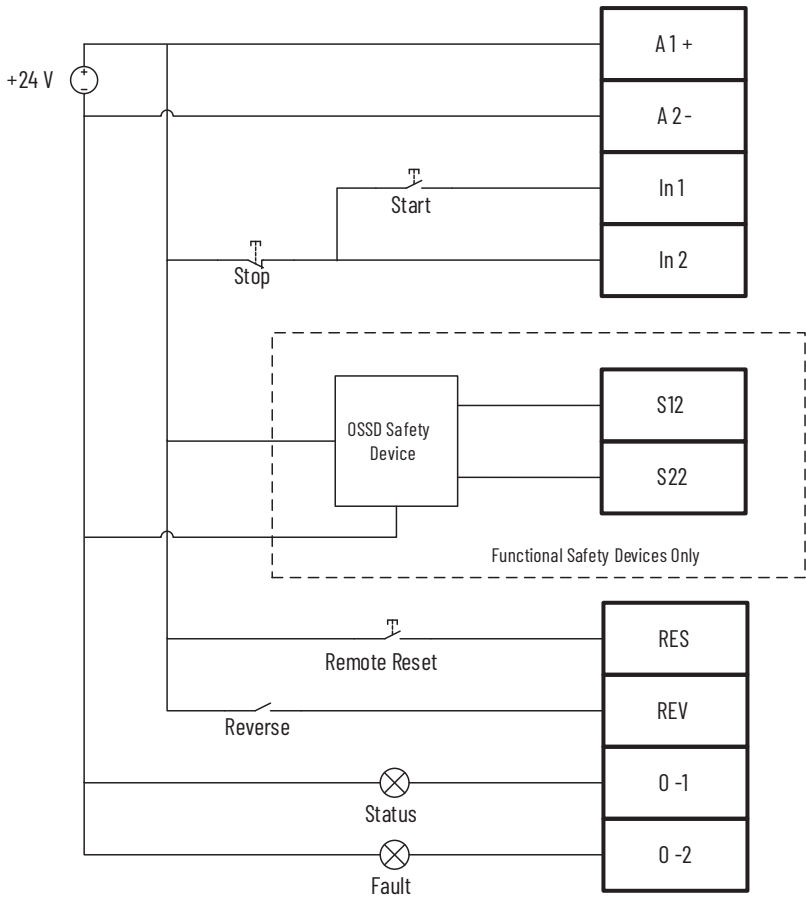
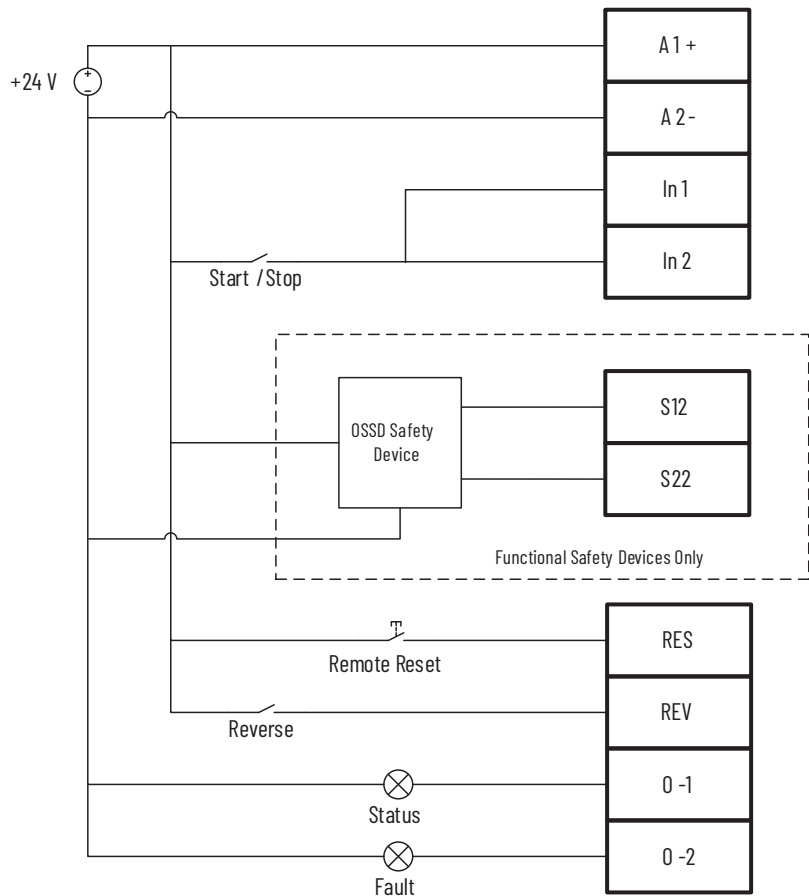

Figure 13 shows the correct wiring to configure the M100 starter for two-wire control.

**Figure 13 - Two-wire Control with OSSD Functional Safety Devices – Remote Reset, Reversing, Auxiliary Outputs**



**Table 11 - Control Wiring Diagram Details**

Item	Description
24V DC positive	Apply to A1+
24V DC negative	Apply to A2-
All inputs	24V DC Use the same signal that is tied to A1+
Return for inputs	Internally connected to A2-
Start/Stop	Appropriate switch configurations to In1 and In2 See <a href="#">Figure 12</a> and <a href="#">Figure 13</a>
Reverse	Reverses motor direction <b>Note:</b> Stop the motor before you change direction <sup>(1)</sup> .
Remote Reset	Use to reset motor trips
Safety Versions	OSSD Device, +24V DC from A1+ Two-channel output to S12, S22 Return to A2-

(1) If motor and load are not stopped before changing motor direction, the motor may encounter high inrush currents that could result in nuisance overload or circuit protection trips.

### Control Power Voltage Source

All M100 starters must use a 24V DC (-15% / +10%) control power source on the A1+/A2- terminals.



The M100 starter is designed with internal overcurrent protection to limit the maximum energy into the control circuit.

For Functional Safety applications, see [Table 4](#).

## Configuration and Operation

### Choose Full Load Ampere Setting

The M100 starter is designed with a rotary switch that can be used to adjust the current range for the protection features.

Set the M100 starter FLA rotary dial to match the motor nameplate FLA.

See [Specifications](#) for more information.

### Choose Single- or Three-phase Power

To configure the M100 starter for single- or three-phase operation, select the appropriate DIP switch setting, which is located on the front of the unit. See [Figure 14](#) for more information.

Figure 14 - Power Phase DIP Switch Location

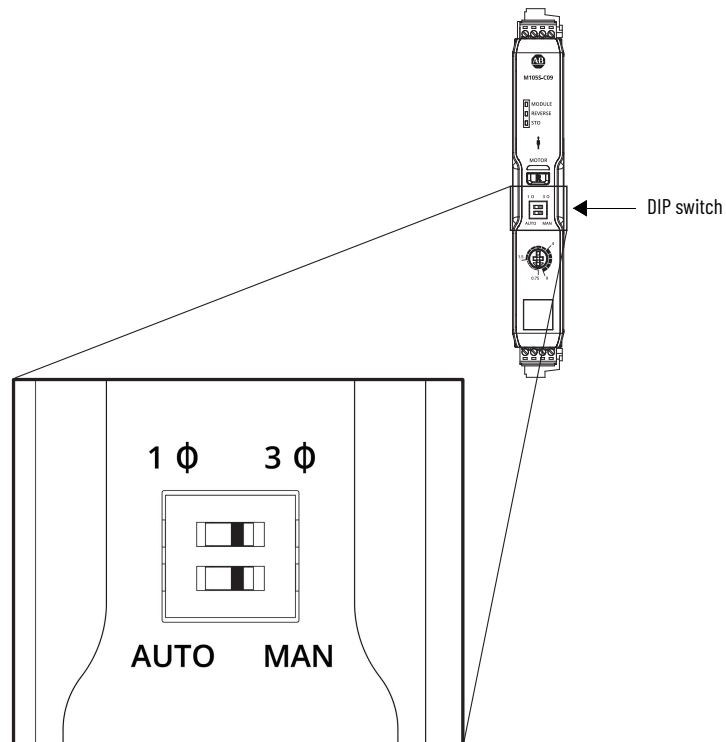

The M100 starter is configured to use three-phase power by default.

To change the system to single-phase, move the top DIP switch to the left position.

Figure 15 - Power Phase DIP Switch Selection

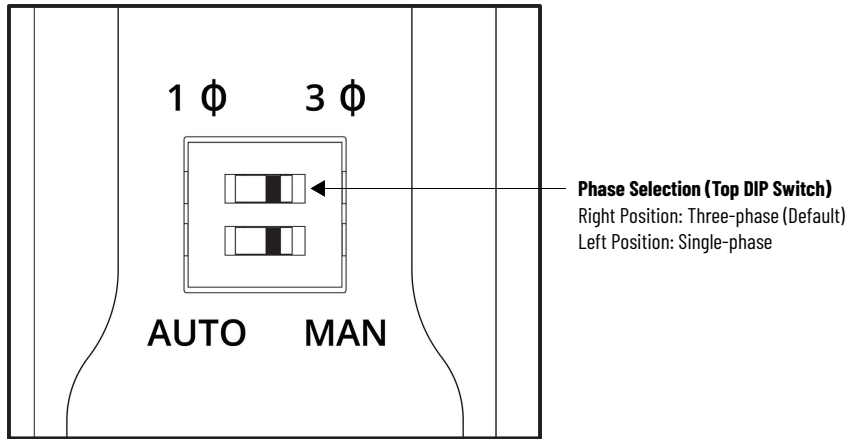

### Automatic Reset

The M100 starter is configured to reset the overload trips manually by default. To change the system to reset the overload trips automatically, move the bottom DIP switch to the left "AUTO" setting.



**WARNING:** If the device is set to Automatic Reset, it will restart automatically. Take precautions to help prevent hazards.



**AVERTISSEMENT:** Si le dispositif est réglé en mode de réinitialisation automatique, il redémarrera automatiquement. Veuillez prendre des précautions pour prévenir les risques.

Figure 16 - Reset DIP Switch Selection

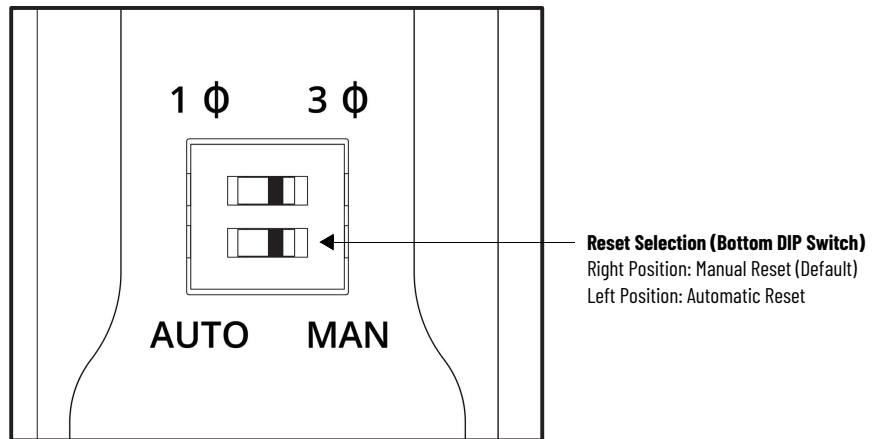

## Auxiliary Output Contactor Status

The M100 starter auxiliary output contactor status has the following functionality.

Table 12 - Contactor Status Output

Contactor State	Output State
Open	0V <sup>(1)</sup>
Closed	+24V DC <sup>(2)</sup>

(1) In this state, the output measures 0V (± 10 mV), with a 240 Ω load to common.

(2) In this state, the output measures the control voltage at AI+ (+0V / -1V), with a 240 Ω load to common.

## Auxiliary Output Fault Status

The M100 starter auxiliary output fault status has the following functionality.

**Table 13 - Fault Status Output**

Fault State	Output State
Not faulted	0V <sup>(1)</sup>
Faulted	+24V DC <sup>(2)</sup>

(1) In this state, the output measures 0V ( $\pm 10$  mV), with a 240  $\Omega$  load to common.

(2) In this state, the output measures the control voltage at A1+ (+0V / -1V), with a 240  $\Omega$  load to common.

## Control Inputs Operation

The M100 starter IN1, IN2, reverse, and reset control inputs are 24V DC ( $U_g$ ), Type 1 rated inputs, as defined in EN 60947-1.

The M100 starter control inputs have the following functionality.



0 refers to state 0 (0V DC) and 1 refers to state 1 (24V DC), as defined in EN60947-1.

**Table 14 - Controls Input**

In1	In2	Action
0	0	Stop Command
1	0	Stop Command
0	1	Maintains current state (stopped or running)
1	1	Start Command

**Table 15 - Reverse Input**

Input	Input Setting	Action
Reverse <sup>(1)</sup>	0	Motor runs in the forward direction
	1	Motor runs in the reverse direction

(1) The motor direction change does not occur until the next motor start command is initiated. The M100 does not prevent flying start commands. To help prevent nuisance tripping, stop the motor load before you issue a start command.

**Table 16 - Remote Reset Input**

Input	Input Setting	Action
Remote Reset (requires N.O. push button)	0	No action
	1	Trip reset

**Notes:**



## Status Indicators

### Motor LED

The M100 starter motor status LED provides the following functionality.

Table 17 - Motor Status LED

LED Indicator	LED Activity	Device State
Off	–	The power contacts are open
Green	Steady on	<ul style="list-style-type: none"> <li>The power contacts are closed</li> <li>The motor is running and no warnings or trips are present</li> </ul>
Yellow	Steady on	<ul style="list-style-type: none"> <li>The power contacts are closed</li> <li>The motor is not running</li> </ul>
Red	Flashing trip ID details: The number of flashes followed by a pause identifies the specific trip code as shown in <a href="#">Table 23</a> .	Tripped
Yellow		Warning

### Module LED

The M100 starter module LED provides the following functionality.

Table 18 - Module Status LED

LED Indicator	LED Activity	Device State
Off	–	The device is powered off
Green	Steady on	<ul style="list-style-type: none"> <li>The module is powered on</li> <li>No internal faults are present</li> </ul>
Red	Steady on	The module has an unrecoverable fault
Red	Flashing	<ul style="list-style-type: none"> <li>The module has an internal hardware fault</li> <li>A power cycle is required</li> </ul>

### Trip and Warning IDs

See [Table 23](#) and [Table 24](#).

### Reversing LED

The M100 starter offers a reversing LED with the following functionality.

Table 19 - Reversing LED

LED Indicator	LED Activity	Device State
Off	–	<ul style="list-style-type: none"> <li>The motor is stopped or</li> <li>The motor is running in the forward direction</li> </ul>
Green	Steady on	The motor is running in the reverse direction

### Safety LED

The M100 starter safety LED indicates the following functional safety functions.



**ATTENTION:** Do not rely only upon LED status indicators for safety operations.

Table 20 - Safety LED

LED Indicator	LED Activity	Device State
Green	Steady on	The M100 starter is in a Safe Torque Off state
Off	–	All other conditions

**Notes:**

## Protection Functions

### Reset a Trip

After the trip condition is removed, the M100 starter can be reset from the Tripped state by using one of the following methods:

- Reset button
- Remote reset control input
- Automatic reset (motor overload only)
- Cycling 24V DC control power

### Reset Button

- To reset a trip, press the reset button.
- To generate a test trip, press and hold the reset button for at least 3 s.
- When a test trip is generated, the Motor Status LED flashes the trip code. For more information, see [Table 17](#) and [Table 23](#).

Also see [Auxiliary Output Fault Status](#) for more information.

### Remote Reset Control Input

When 24V DC is applied to the reset (RES) input, a trip reset signal is sent. If the trip condition is no longer present, the fault is reset.

## Trip Reset

The M100 starter has the following trip reset functionality.

**IMPORTANT** After you reset a trip, cycle the stop input signal before you start the motor.

**Figure 17 - Trip Reset for Three-wire Configurations**

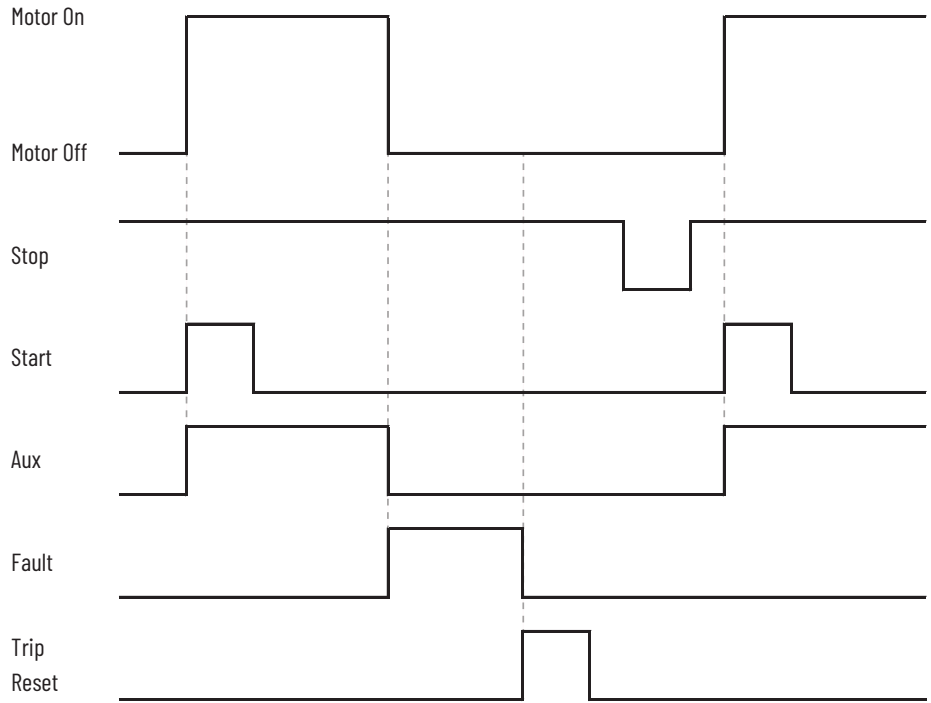

**Figure 18 - Trip Reset for Two-wire Configurations**

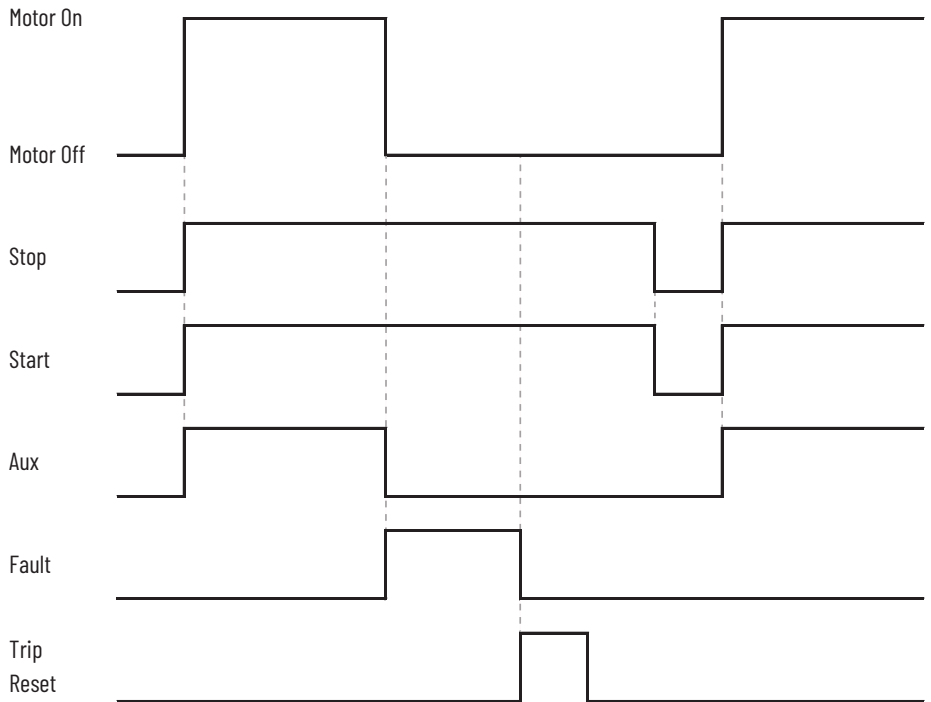

## Thermal Overload Protection

The M100 starter provides Class 10 thermal overload protection, which is always enabled.

When the motor Thermal Capacity Utilization (TCU), is equal to or greater than 100%, an overload trip signal is generated and the Motor Status LED flashes the trip code. For more information, see [Table 17](#) and [Table 23](#).

When a trip reset is issued and the TCU is less than 70%, a thermal overload trip can be reset. When automatic reset is enabled, and the TCU is less than 70%, a thermal overload trip is automatically cleared.

A thermal overload warning occurs when the TCU value is greater than or equal to 90%.

The thermal overload warning is cleared when the TCU value drops below the thermal overload warning level.

# Trip Curves

Figure 19 - Trip Curves— 9 A

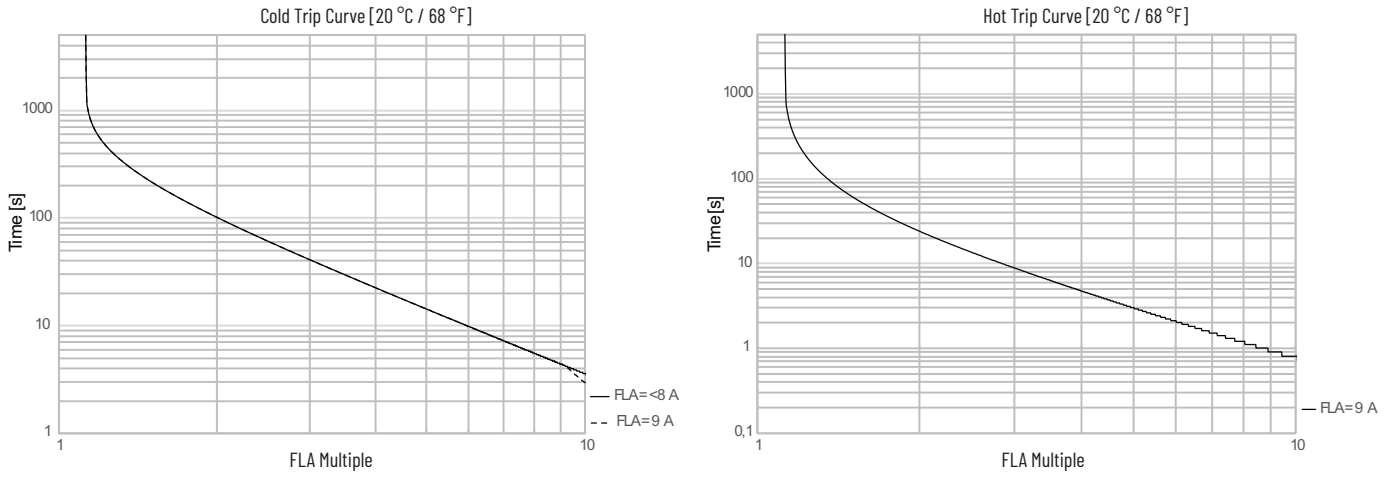

Figure 20 - Trip Curves — 23 A

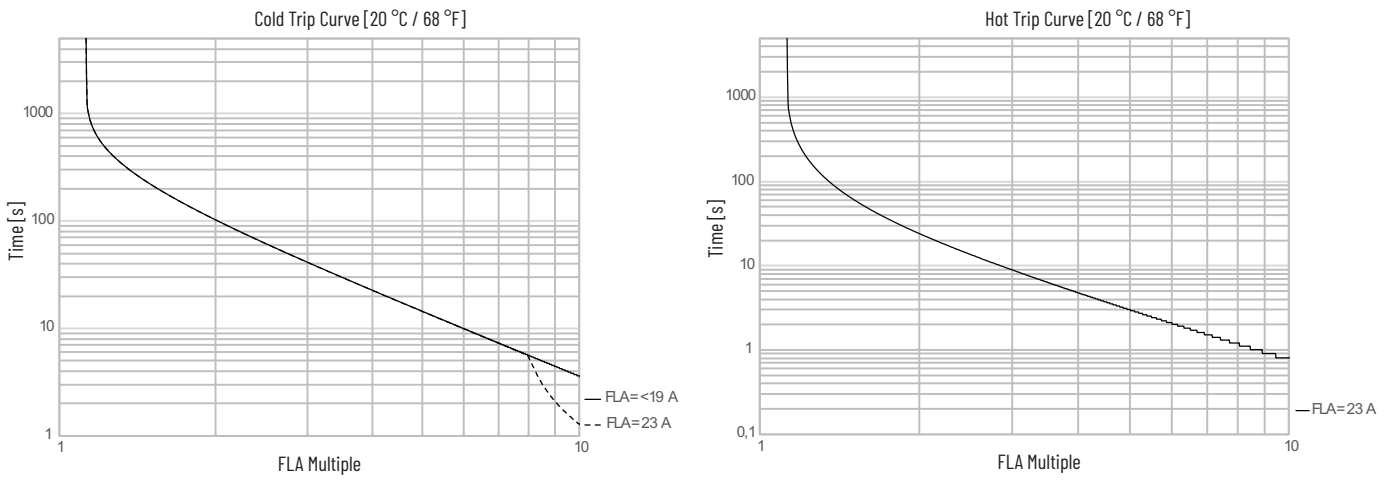

Figure 21 - Maximum Starts per Minute @ 20 °C (68 °F) – 9 A and 23 A Devices, 80% FLA

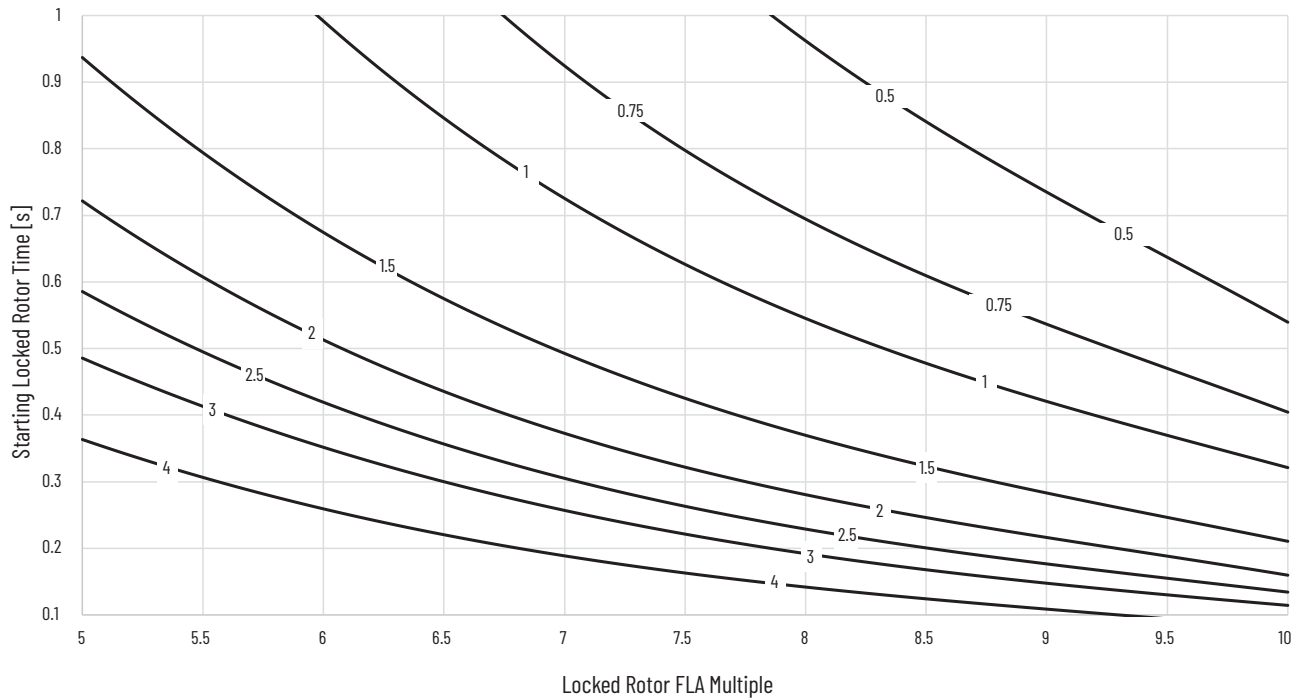

Figure 22 - Maximum Starts per Minute @ 20 °C (68 °F) – 9 A and 23 A Devices, 100% FLA

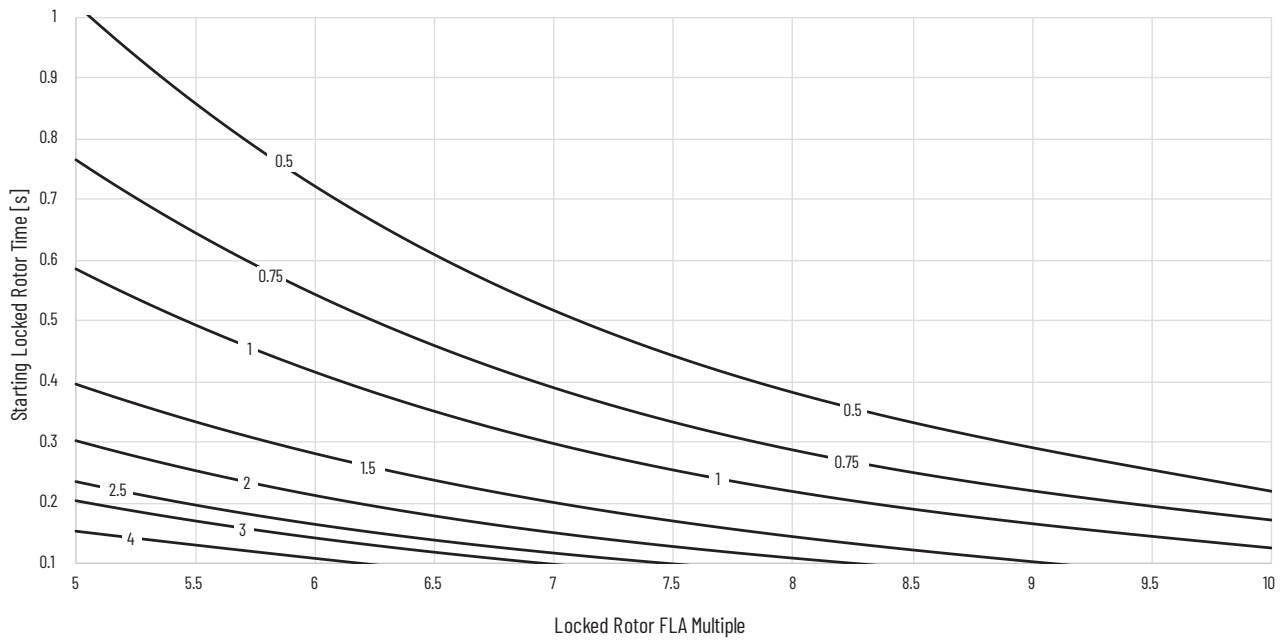
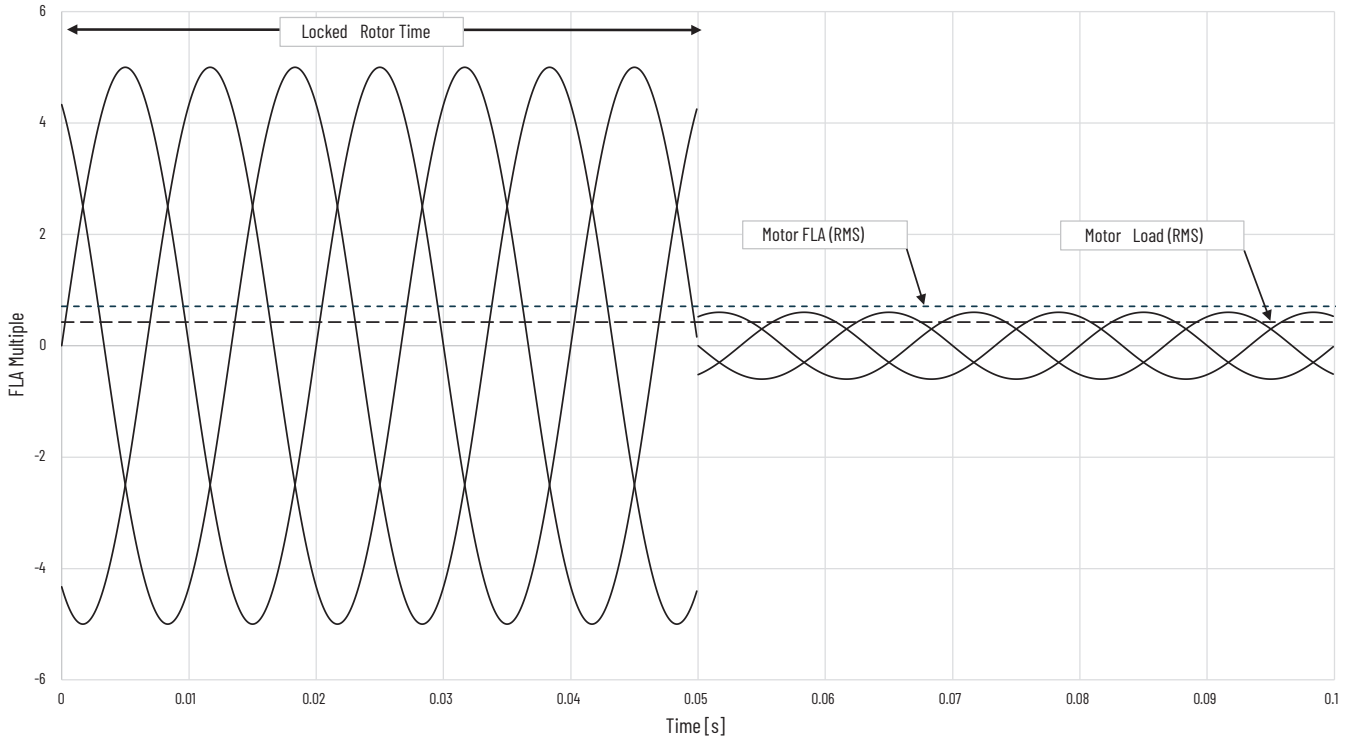

Figure 23 - Simplified Motor Start





## Phase Loss Protection

The M100 starter provides phase loss protection when controlling three-phase motors. Phase loss protections are disabled when controlling single-phase motors.

When a phase loss condition exists for 3 seconds, the device generates a phase loss fault. In this case, the Motor Status LED flashes the trip code. For more information, see [Table 17](#) and [Table 23](#). Phase loss trips are cleared when a trip reset occurs.

A phase loss warning signal is sent when a phase loss condition exists for at least 0.1 seconds. The Motor Status LED flashes the trip code. For more information, see [Table 17](#) and [Table 23](#).

## Contact Weld Protection

When a motor start command is issued, the M100 starter performs a diagnostic test. If the starter detects a welded power contact in any phase, it generates a hardware fault.

## Single-phase Miswiring Protection

The M100 starter has the following single-phase miswiring access operation, trip levels, and reset options.

**Table 21 - Single-phase Miswiring Protection**

Attribute	Value
Single-phase miswiring trip	<ul style="list-style-type: none"> <li>• Sent when a single-phase miswiring condition exists for 1 s</li> <li>• The Motor Status LED flashes the trip code</li> <li>• See <a href="#">Table 17</a> and <a href="#">Table 23</a></li> </ul>
Single-phase miswiring trip reset	Cleared when the trip is reset

## Phase Imbalance Protection

The M100 starter has the following phase imbalance protection operation, trip levels, and reset options.

**Table 22 - Phase Imbalance Protection**

Attribute	Value
Phase imbalance access	<ul style="list-style-type: none"> <li>• Enabled when operating three-phase mode</li> <li>• Cannot be disabled when operating three-phase mode</li> <li>• Disabled when operating in single-phase mode</li> </ul>
Phase imbalance function	<ul style="list-style-type: none"> <li>• Enabled (motor running) when the calculated current imbalance is:               <ul style="list-style-type: none"> <li>- greater than 50%</li> <li>and</li> <li>- the average current is greater than 30% min FLA</li> </ul> </li> </ul>
Current imbalance calculation	The maximum difference between each phase current and the average phase current, divided by the average current
Phase imbalance trip	<ul style="list-style-type: none"> <li>• Enabled when a phase imbalance condition exists for <math>\geq 10</math> s</li> <li>• The Motor Status LED flashes the trip code</li> <li>• See <a href="#">Table 17</a> and <a href="#">Table 23</a></li> <li>• Cleared when the trip is reset</li> </ul>
Phase imbalance warning signal	<ul style="list-style-type: none"> <li>• Signal sent when a phase imbalance condition exists for at least 0.1 s</li> <li>• The Motor Status LED flashes the trip code</li> <li>• See <a href="#">Table 17</a> and <a href="#">Table 23</a></li> <li>• Cleared when the phase imbalance condition ends</li> </ul>

**Notes:**

## Troubleshooting

### Introduction

If the M100 starter encounters any errors, refer to the fault and warning code information that is contained in this section.

For safety of maintenance personnel and others who might be exposed to electrical hazards associated with maintenance activities, follow the local safety-related work practices (for example, NFPA 70E, Part II in the United States). Maintenance personnel must be trained in the safety practices, procedures, and requirements that pertain to their respective job assignments.



**WARNING:** Servicing energized industrial control equipment can be hazardous. Electrical shock, burns, or unintentional actuation of controlled industrial equipment may cause death or serious injury. For safety of maintenance personnel and others who may be exposed to electrical hazards associated with the maintenance activities, follow the local safety-related work practices (for example, the NFPA 70E, Part II, Electrical Safety for Employee Workplaces, in the United States) when working on or near energized equipment.

**WARNING:** Maintenance personnel must be trained in the safety practices, procedures, and requirements that pertain to their respective job assignments.

**WARNING:** Do not work alone on energized equipment.



**AVERTISSEMENT:** Intervenir sur un équipement de commande industriel sous tension peut être dangereux. Les risques d'électrocution, de brûlure ou l'activation involontaire d'équipements industriels commandés risque de provoquer des blessures graves, voire mortelles. Pour la sécurité du personnel de maintenance et des autres personnes pouvant être exposées aux risques d'électrocution liés aux activités de maintenance, observez les directives de sécurité locales (par exemple, la directive NFPA 70E, Part II, Electrical Safety for Employee Workplaces, aux États-Unis) lors d'intervention sur des équipements sous tension ou à proximité de ceux-ci.

**AVERTISSEMENT:** Le personnel de maintenance doit être formé aux pratiques, procédures et exigences de sécurité associées à ses missions respectives.

**AVERTISSEMENT:** Ne travaillez pas seul sur un équipement sous tension.

## Fault and Warning Codes

Table 23 - Motor Fault and Warning Codes

Fault/ Warning Code	Condition	Possible Causes	Possible Solutions
1	Overload	Motor overloaded	Check motor overload condition
		Overload dial setting is not matched to the motor	Check FLA dial setting and motor FLA rating Verify current draw of the motor
2	Phase Loss	High impedance line connection	Check for open line- and load-side connections Check for loose line- and load-side connections
		Missing supply phase	Check for open line (for example, a blown fuse)
		Motor not connected properly	Check for open motor lead(s)
		Incoming three-phase voltage instability	Verify power quality
		Loss of load side power wiring	Check all load-side power connections Check motor windings (insulation resistance tester)
3...6 9, 10	Reserved	—	—
7	Phase Imbalance	Power line unbalance is greater than preprogrammed values See <a href="#">Table 22</a>	Check the power system and correct if necessary
8	Single-phase Miswire (Trip only)	Single-phase motor or power is not wired correctly	Check single-phase power and motor wiring See <a href="#">Figure 11</a>
		DIP switch setting incorrect	Check DIP switch setting See <a href="#">Figure 15</a>
11	Test Fault	The M100 starter controller reset button was pressed for more than 3 seconds	To reset the Test fault, press the reset button for less than 2 seconds
		The M100 starter controller reset button is stuck or damaged	Attempt to dislodge the reset button Replace the device if necessary

Table 24 - Module Fault Codes

Fault Code	Condition	Possible Causes	Possible Solutions
1	Device Overtemperature	Controller ventilation blocked	Check for proper controller ventilation
		Controller duty cycle exceeded	Check application-appropriate duty cycle
		Ambient temperature limit exceeded	Wait for controller to cool If ambient temperature is high, provide external cooling
2	NVS Error	Controller Memory Corrupted	Cycle control power Replace device
3	Device Reset	Device Reset	Verify that 24V DC control power is within specification See <a href="#">Control Power Voltage Source</a>
			Cycle control power Replace device
4	User Interface Error	User interface control not recognized	Check all control wiring Confirm that control voltage is within specification See <a href="#">Control Power Voltage Source</a>
			Cycle control power Replace device
5	Control Power out of Range	Control power source out of range	Verify that 24V DC control power is within specification See <a href="#">Control Power Voltage Source</a>
			Cycle control power Replace device
6...10	Power Supply out of Range	Internal power supply out of range	Cycle control power Contact <a href="#">Rockwell Automation Support</a>
			Replace device
11...13	Safety Input Error <sup>(1)</sup>	Error on safety input voltage	Confirm OSSD safety device functionality Confirm OSSD safety device output voltage is within specifications See <a href="#">Control Power Voltage Source</a>
			Cycle control power Contact <a href="#">Rockwell Automation Support</a>
			Replace device
14...18	Safety Diagnostics Error <sup>(1)</sup>	Internal safety diagnostics error	Cycle control power Contact <a href="#">Rockwell Automation Support</a>
			Replace device

(1) Active on functional safety devices only.

**Notes:**

**Notes:**

# Rockwell Automation Support

Use these resources to access support information.

<b>Technical Support Center</b>	Find help with how-to videos, FAQs, chat, user forums, Knowledgebase, and product notification updates.	<a href="http://rok.auto/support">rok.auto/support</a>
<b>Local Technical Support Phone Numbers</b>	Locate the telephone number for your country.	<a href="http://rok.auto/phonesupport">rok.auto/phonesupport</a>
<b>Technical Documentation Center</b>	Quickly access and download technical specifications, installation instructions, and user manuals.	<a href="http://rok.auto/techdocs">rok.auto/techdocs</a>
<b>Literature Library</b>	Find installation instructions, manuals, brochures, and technical data publications.	<a href="http://rok.auto/literature">rok.auto/literature</a>
<b>Product Compatibility and Download Center (PCDC)</b>	Download firmware, associated files (such as AOP, EDS, and DTM), and access product release notes.	<a href="http://rok.auto/pcdc">rok.auto/pcdc</a>

## Documentation Feedback

Your comments help us serve your documentation needs better. If you have any suggestions on how to improve our content, complete the form at [rok.auto/docfeedback](http://rok.auto/docfeedback).

## Waste Electrical and Electronic Equipment (WEEE)



At the end of life, this equipment should be collected separately from any unsorted municipal waste.





Rockwell Automation maintains current product environmental compliance information on its website at [rok.auto/pec](http://rok.auto/pec).

Allen-Bradley, expanding human possibility, ProposalWorks, and Rockwell Automation are trademarks of Rockwell Automation, Inc.

EtherNet/IP is a trademark of ODVA, Inc.

Trademarks not belonging to Rockwell Automation are property of their respective companies.

Rockwell Otomasyon Ticaret A.Ş. Kar Plaza İş Merkezi E Blok Kat:6 34752, İçerenköy, İstanbul, Tel: +90 (216) 5698400 EEE Yönetmeliğine Uygundur

Connect with us.    

**rockwellautomation.com** ————— **expanding human possibility®**

AMERICAS: Rockwell Automation, 1201 South Second Street, Milwaukee, WI 53204-2496 USA, Tel: (1) 414.382.2000

EUROPE/MIDDLE EAST/AFRICA: Rockwell Automation NV, Pegasus Park, De Kleetlaan 12a, 1831 Diegem, Belgium, Tel: (32) 2663 0600

ASIA PACIFIC: Rockwell Automation SEA Pte Ltd, 2 Corporation Road, #04-05, Main Lobby, Corporation Place, Singapore 618494, Tel: (65) 6510 6608

UNITED KINGDOM: Rockwell Automation Ltd., Pitfield, Kiln Farm, Milton Keynes, MK11 3DR, United Kingdom, Tel: (44)(1908) 838-800

Publication M100-UM001A-EN-P - February 2025

Copyright © 2025 Rockwell Automation, Inc. All rights reserved. Printed in the U.S.A.