



Bulletin 1336 **Adjustable Frequency AC Drive**

1336 B150 – B200
1336 C150 – C200
1336VT B200 – B250

Troubleshooting Guide and Renewal Parts





1336 Adjustable Frequency AC Drive

Troubleshooting Guide and Renewal Parts Publication 1336-6.4 – October, 1995



1336 Adjustable Frequency AC Drive

Troubleshooting Guide and Renewal Parts Publication 1336-6.4 – October, 1995

Important User Information



ATTENTION: Identifies information about practices or circumstances that can lead to personal injury or death, property damage or economic loss.

Attentions help you:

- Identify a hazard.
- Avoid the hazard.
- Recognize the consequences.

IMPORTANT: Identifies information that is especially important for successful application and understanding of the product.



SHOCK HAZARD labels may be located on or inside the drive to alert people that dangerous voltage may be present.

Summary Information

We would like to call your attention to the following changes to the 1336-6.4 manual which have occurred since the previous version published in July, 1994. All references to page numbers refer to the July publication. Page numbers in the October, 1995 publication may not match the page-number references mentioned here due to omissions or inclusions and, likewise, text and graphics shifting somewhat from page to page.

Chapter 1

- Figure 1.10, Precharge Board Test, on page 1-36 has been modified.

Chapter 3

- A Precharge Resistors section has been added.

Chapter 4

- Figure 4.1, Replacement Parts for B150 – B200, C150 – C200, and 1336 VT B200 – B250 Drives, on page 4-2 has been modified.
- Table 4.A, Replacement Parts for B150 – B200 Drives, has been modified to include C150 – C200 and 1136VT B200 – B250 Drive information. Drive Rating information has been removed.
- Table 4.B, Replacement Parts for C150 – C200 Drives, has been removed.
- Table 4.C, Replacement Parts for 1336VT B200 – B250 Drives, has been removed.

Summary of Changes

This Page Intentionally Left Blank

Preface

Manual Objective	P-1
Who Should Use This Manual	P-1
Safety Precautions	P-1
1336 Product Identification	P-2
Dive Nameplate Location	P-2
Drive and Option Identification	P-3
Bulletin Number	P-3
Drive Rating	P-3
Enclosure Type	P-5
Factory Installed Options	P-6
Conventions	P-7
Related Publications	P-9

Troubleshooting and Error Codes

Chapter 1

Chapter Objectives	1-1
Troubleshooting Overview	1-1
Electrostatic Discharge Precautions	1-2
Detailed Product Identification	1-2
Logic Interface Options	1-3
1336-MOD-L1 Logic Interface Options	1-4
1336-MOD-L2 and-L3 Logic Interface Options	1-5
Basic Drive Control and Fault Display	1-6
Local Programming	1-6
Operation	1-8
Fault Code Descriptions	1-13
Clearing Faults	1-13
Diagnostic Procedures by Symptom	1-19
No Display	1-19
Drive Will Not Start	1-20
Drive Will Not Jog	1-22
Drive Stays at Zero Hertz When Started	1-24
Drive Goes to Max Frequency	1-25

Neon Bus Light Not Illuminated 1-26

Drive Starts, No Output at M1 – M3 1-27

Component Electrical Tests 1-28

Test 1 – Testing the Bridge Rectifiers 1-28

Test 2 – Testing the Bus Capacitors 1-31

Test 3 – Testing Transistor Modules X1 – X6 1-34

Test 4 – Testing the Precharge Board 1-36

Test 5 – Testing the Base Driver/Power Supply Board 1-38

Disassembly and Access Procedures

Chapter 2

Chapter Objectives 2-1

Disassembly and Access Overview 2-1

Electrostatic Discharge Precautions 2-1

Fastener Torque Specifications 2-2

Disassembly and Access Procedures 2-4

 Removing the Drive Enclosure 2-4

 Removing Logic Interface Board MOD-L1, -L2, or -L3 2-7

 Removing the Programming and Display Board 2-9

 Removing the Main Control Board from the Mounting Plate 2-11

 Removing the Main Control Mounting Plate 2-13

 Removing the Precharge Board 2-15

 Removing the Base Driver/Power Supply Board 2-17

 Removing the Base Driver Mounting Plate 2-19

 Removing the Main Bus Bar Assembly 2-21

Accessing Chassis Power Components 2-22

Part Replacement Procedures

Chapter 3

Chapter Objective 3-1

Part Replacement Overview 3-1

Safety Precautions 3-1

Electrostatic Discharge Precautions 3-1

Fastener Torque Specifications 3-2

Major Component Replacement 3-4

 Precharge Resistors 3-5

 SCR Modules 3-7

Thermostat ST 3-9

Transistor Modules and Snubbers 3-11

Ground Sense CT 3-15

Surge Suppressor MOV1 3-17

Fan 3-19

Transformer T1 3-22

DC Bus Inductor L1 3-24

Bus Capacitors 3-26

Bus Sense Module 3-29

LEM A and LEM C 3-31

Bus Diode D1 3-33

Bus Fuse F1 3-35

Load Reactor LR 3-37

Replacement Parts List

Chapter 4

Chapter Objectives 4-1

Ordering Replacement Parts 4-1

Replacement Parts Listing 4-2

..... G-1

150 – 200 HP 1336 Drives S-1

240 and 300 Amp 1336VT Drives S-5

..... N-1

Glossary

Schematics

Notes

This Page Intentionally Left Blank

Preface

Manual Objective

The information in this manual is designed to help troubleshoot or repair an Allen-Bradley Bulletin 1336 Adjustable Frequency AC Drive with ratings B150 – B200, C150 – C200, and VT B200 – B250.

Who Should Use This Manual

This manual is intended for qualified service personnel responsible for troubleshooting and repairing the 1336 Adjustable Frequency AC Drive. You should:

- Read this entire manual before performing maintenance or repairs to drives.
- Have previous experience with, and basic understanding of, electrical terminology, procedures, required troubleshooting equipment, equipment protection procedures and methods, and safety precautions.

This manual describes equipment, troubleshooting, and disassembly procedures. You begin with general illustrations and end with greater detail concerning replacement parts and part locations on the drives. Later chapters may refer you back to earlier chapters for information on basic equipment and steps necessary to perform detailed diagnostics and part replacement.

Safety Precautions



ATTENTION: Some printed circuit boards and drive components may contain hazardous voltage levels. If neon light DS 1 on the Base Driver Board is illuminated, hazardous voltages are present in the drive circuit boards. Remove and lock out power before you disconnect or reconnect wires, and before you remove or replace fuses and circuit boards. Verify bus voltage by measuring the voltage between +DC and –DC on Terminal Block TB1. Do not attempt to service the drive until the neon indicator has extinguished and the bus voltage has discharged to zero volts.

Electrostatic Discharge Precautions



ATTENTION: This assembly contains parts and sub-assemblies that are sensitive to electrostatic discharge. Static control precautions are required when servicing this assembly. Component damage may result if you ignore electrostatic discharge control procedures. If you are not familiar with static control procedures, reference Allen-Bradley Publication 8000 – 4.5.2, Guarding Against Electrostatic Damage, or any other applicable ESD protection handbook.

Electrostatic discharge generated by static electricity can damage the complimentary metallic oxide semiconductor devices on various drive boards. It is recommended that you perform these procedures to guard against this type of damage when circuit boards are removed or installed:

- Wear a wrist type grounding strap that is grounded to the drive chassis.
- Attach the wrist strap before removing the new circuit board from the conductive packet.
- Remove boards from the drive and immediately insert them into their conductive packets.

1336 Product Identification

Drive Nameplate Location

The drive nameplate is located on the face of the Main Control Board Mounting Plate. The drive nameplate contains the drive's catalog number and other important drive information. Reference the catalog number when ordering replacement parts.

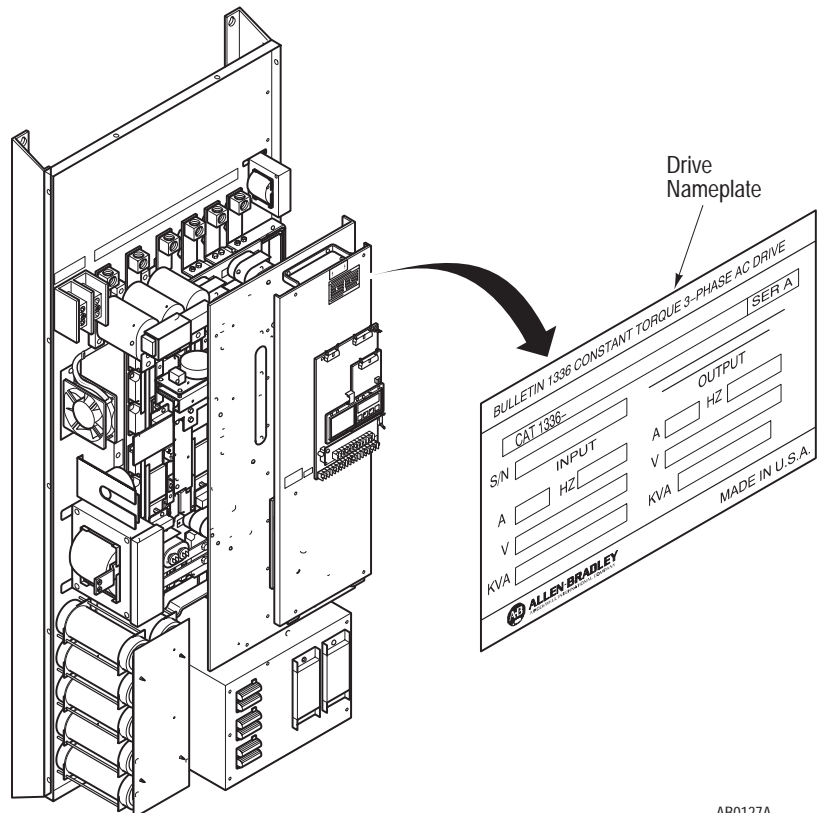

AB0127A

Drive and Option Identification

The following is an explanation of the catalog numbering system for 1336 Adjustable Frequency AC Drives and options. The catalog number is coded to identify the drive power rating and can be found on the drive shipping carton and nameplate.

1336 Drive Catalog Numbers

1336	–	B150	–	EAE	–	FA2	–	L2	–	S1
Bulletin Number		Drive Rating		Enclosure Type		Options		Options		Options

Bulletin Number

The Bulletin Number is the Allen-Bradley reference number identifying the type or family of products.

Drive Rating

A Drive Rating is a coded group of four characters indicating input voltage and output power rating.

The first character indicates the input voltage range of the drive:

- Drives with a code “B” are suitable for operating from any one of the following input voltages: 380/415/460V AC, 50/60 Hz, 3-phase.
- Drives with a code “C” are suitable for operating only from 500/575/600V AC, 50/60 Hz, 3-phase input voltages.

Fan Transformer Reconnection for Alternate Drive Input Voltages

IMPORTANT:

For drives rated C003 – C200, reconnection of Fan Transformer T1 is not necessary.

For drives rated B003 – B030, reconnection of Fan Transformer T1 is not necessary.

For drives rated B040 – B200, Fan Transformer T1 must be reconnected for 380 or 415V operation. If Fan Transformer T1 is not connected to match the incoming voltage, overtemperature fault F08 may occur. Refer to Chapter 1 – Troubleshooting and Error Codes, Wiring and Interface Options, for wiring details.

The second, third, and fourth characters in the Drive Rating indicate the power rating of the drive, as shown in Tables 1.A, 1.B, and 1.C.

Table 1.A
B003 – B200 Output Current and KVA

Rating Code	Amp Out	KVA Out at 380V AC	KVA Out at 415V AC	KVA Out at 460V AC
B003	6.0	3.9	4.3	4.8
B005	9.6	6.3	6.9	7.6
B007	13.0	8.6	9.3	10.4
B010	17.0	11.2	12.2	13.5
B015	25.0	16.5	18.0	20.0
B020	33.0	22.0	24.0	26.0
B025	41.0	27.0	29.0	33.0
B030	48.0	32.0	35.0	38.0
B040	60.0	39.0	43.0	48.0
B050	75.0	49.0	54.0	60.0
B075	120.0	79.0	86.0	96.0
B100	150.0	99.0	108.0	120.0
B125	180.0	118.0	129.0	143.0
B150	218.0	143.0	157.0	174.0
B200	290.0	191.0	208.0	231.0

Table 1.B
C003 – C200 Output Current and KVA

Rating Code	Amp Out	KVA Out 500V AC	KVA Out 575V AC	KVA Out 600V AC
C003	4.3	3.7	4.3	4.3
C005	6.7	5.8	6.7	6.7
C007	9.9	8.6	9.9	9.9
C010	12.1	10.5	12.1	12.1
C015	19.1	16.5	18.9	18.9
C020	24.0	20.8	23.9	23.9
C025	30.0	26.0	29.9	23.9
C030	35.0	30.3	34.9	34.9
C040	45.0	39.0	44.9	44.9
C050	57.0	49.4	56.8	56.8
C075	85.0	73.6	84.7	84.7
C100	109.0	94.4	108.6	108.6
C125	138.0	119.5	137.4	137.4
C150	158.0	136.8	157.4	157.4
C200	210.0	181.9	209.1	209.1

Table 1.C
1336VT B003 – B250 Output Current and KVA

Rating Code	Amp Out	KVA Out at 380V AC	KVA Out at 415V AC	KVA Out at 460V AC
B003	5.0	3.3	3.6	4.0
B005	8.0	5.3	5.8	6.4
B007	11.0	7.2	7.9	8.8
B010	14.0	9.2	10.1	11.2
B015	21.0	13.8	15.1	16.7
B020	27.0	17.8	19.4	21.5
B025	34.0	22.4	24.4	27.1
B030	40.0	26.3	28.8	31.9
B040	52.0	34.2	37.4	41.4
B050	65.0	42.8	46.7	51.8
B060	77.0	50.7	55.3	61.3
B075	96.0	63.2	69.0	76.5
B100	124.0	81.6	89.1	98.8
B125	156.0	102.7	112.1	124.3
B150	180.0	118.5	129.4	143.4
B200	240.0	158.0	172.5	191.2
B250	300.0	197.4	215.6	239.0

Enclosure Type

The first character, E, indicates the Enclosure Code.

The second character indicates the type of enclosure shipped from the factory:

Table 1.D
Enclosure Type Code Description

Enclosure Type Code	Description
0	Open style (IP00)
A	NEMA Type 1 (IP20)
C*	NEMA Type 4 (IP56)
J*	NEMA Type 12 (IP54)

*Not available on 1336VT.

The third character indicates enclosure size by frame size:

Table 1.E
Enclosure Amp Rating Code Description

Enclosure Type Code	HP/Amp Drive Rating
D	003, 005, 007, or 010
E	015 or 020
F	025 or 030
G	040 or 050
H	075, 100, or 125
J	150 or 200
N	VT 5.0, 8.0, 11.0, 14.0, or 21.0
P	VT 27.0 or 34.0
R	VT 40 or 52
S	VT 65.0 or 77.0
T	VT 96.0, 124.0, 156.0, or 180.0
W	VT 240.0 or 300.0

Factory Installed Options

All additional characters in the catalog number indicate drive options installed at the factory. Each Option Code is added to the catalog number and each is separated by a hyphen.

Table 1.F
Drive Option Code Description

Option Code	Description
FA2	Basic control panel for open or NEMA Type 1 enclosures.
FC3	Basic control panel for NEMA Type 4 enclosures.
FJ3	Basic control panel for NEMA Type 12 enclosure.
L1	+5V DC TTL Logic Contact Closure Interface Board.
L2	+24 V DC Logic Interface Board.
L3	115 V AC Logic Interface Board.
S1	Serial Port connector.

Conventions

The following is a list of conventions used throughout this manual, and definitions of the conventions. For a list of terminology and definitions, refer to the Glossary in the back of this manual.

AUX Input

The AUX (Auxiliary Interlock) Input is a terminal connection on the Logic Interface Board. This connection provides a mandatory input for start commands. The drive will not recognize a Start command unless the AUX Input is logically true.

Auxiliary Interlock

The Auxiliary Interlock is a user supplied circuit such as reset, overload, or some logical true-state connection associated with the drive AUX input.

Bit

A bit is a single character or status point used in programmable logic. Eight bits form a BYTE, 16 bits form a word. Drive parameters are actually eight bits or 16 bit words.

Check

To check means to examine either the physical condition of something or the setting of some control, such as a Parameter. Checking a drive board or component may also require measurements and tests.

Connector

A connector connects one drive board to another. Connectors come in two designs, male and female. Male connectors are stationary and contain pins, which are sometimes joined by jumpers. Female connectors are mobile and plug into male connectors.

Default

When a drive function defaults, it automatically changes to a pre-programmed setting.

Enable Input

The Enable Input is a terminal connection on the Logic Interface Board. This connection provides similar functions as the AUX Input. It must also be true to permit the drive to operate.

False

False refers to a logical false state. For instance, the Logic Interface signals on TB3, Terminal 22, are false when MOD-L1 contact is open or the appropriate voltage is not applied to the L2 or L3.

Hand-Held Terminal

A hand-held terminal is a 1336-MOD-E1 programming terminal that plugs into the Serial Interface Port. This terminal allows you to adjust Parameters while the drive is operating.

Jumper

A jumper completes a circuit between two pins within a male connector on a drive board. In the absence of certain optional equipment using female connectors, jumpers are applied to certain pins within a male connector to complete specific and necessary circuits.

Logic Interface Board

A Logic Interface Board connects to junctions J8 and J9, located on the lower portion of the Main Control Board. This board is identified as MOD-L1, -L2, or -L3 and provides optional control wiring configurations for a drive.

Parameter

Parameters are programmable drive functions that define various operating modes of a drive. Refer to Bulletin 1336 Adjustable Frequency AC Drive Programming Manual for Parameter details.

Press

Press a button on the drive's Programming and Display Board to change Parameter settings and drive functions, or to program the drive.

Set

In this manual, set refers to entering information into the drive by changing Parameter values or by changing a setting on a selector switch.

True

True refers to a logical true state. For instance, the Logic Interface signals on TB3, Terminal 22, are true when: MOD-L1 is controlled by a contact closure only and no voltage is present; MOD-L2 registers 24V DC; MOD-L3 registers 115V AC.

Related Publications

The following lists other Allen-Bradley publications that apply to the 1336 Adjustable Frequency AC Drives with ratings B150 – B200, C150 – C200, and VT B200 – B250:

- Hardware Manual
- Programming Manual
- Renewal Parts List

This Page Intentionally Left Blank

Troubleshooting and Error Codes

Chapter Objectives

This chapter helps you trace faults to field-replaceable components.

Troubleshooting Overview

To troubleshoot a 1336 Adjustable Frequency AC Drive, you need the following:

- A Range DVM, DMM, or VOM with a range capacity of at least 1000 V.
- An oscilloscope with a frequency-response range of at least 1 MHz.
- A1336-MOD-E1.

IMPORTANT: All printed circuit boards, except the Main Control Board assembly, are referenced to negative ground (–bus).



ATTENTION: Some printed circuit boards and drive components may contain hazardous voltage levels. If neon light DS1 on the Base Driver Board is illuminated, hazardous voltages are present in the drive circuit boards. Remove power before you disconnect or reconnect wires, and before you remove or replace fuses and circuit boards. Verify bus voltage by measuring the voltage between +DC and –DC on Terminal Block TB1. Do not attempt to service the drive until the neon indicator has extinguished and the bus voltage has discharged to zero volts.



ATTENTION: To guard against equipment damage when troubleshooting the drive, always check the following before issuing a Start command:

- Set the Speed Reference to minimum.
 - Select the proper motor-rotation direction.
 - Disconnect the motor from its mechanical load.
-



ATTENTION: This assembly contains parts and sub-assemblies that are sensitive to electrostatic discharge. Static control precautions are required when servicing this assembly. Component damage may result if you ignore electrostatic discharge control procedures. If you are not familiar with static control procedures, reference Allen-Bradley Publication 8000 – 4.5.2, Guarding Against Electrostatic Discharge, or any other applicable ESD protection handbook.

Electrostatic Discharge Precautions

Electrostatic Discharge generated by static electricity can damage the complimentary metallic oxide semiconductor devices on various drive boards. It is recommended that you perform these procedures to guard against this type of damage when circuit boards are removed or installed:

- Wear a wrist type grounding strap that is grounded to the chassis.
- Attach the wrist strap before removing the new circuit board from the conductive packet.
- Remove boards from the drive and immediately insert them into their conductive packets.

IMPORTANT: Before clearing a fault, refer to the Fault Code Description table and Diagnostic Procedures by Symptom flowchart in this chapter to isolate and correct faults.

Detailed Product Identification

Allen-Bradley Adjustable Frequency AC Drives are modular by design to enhance troubleshooting and spare parts replacement, thereby reduce production down-time.

The following illustration calls out the main components of a B150, C150, or 1336VT B200 drive, as discussed in this chapter. Component designs vary slightly among the different drive ratings, but component locations are identical.

Figure 1.1
Main Drive Components

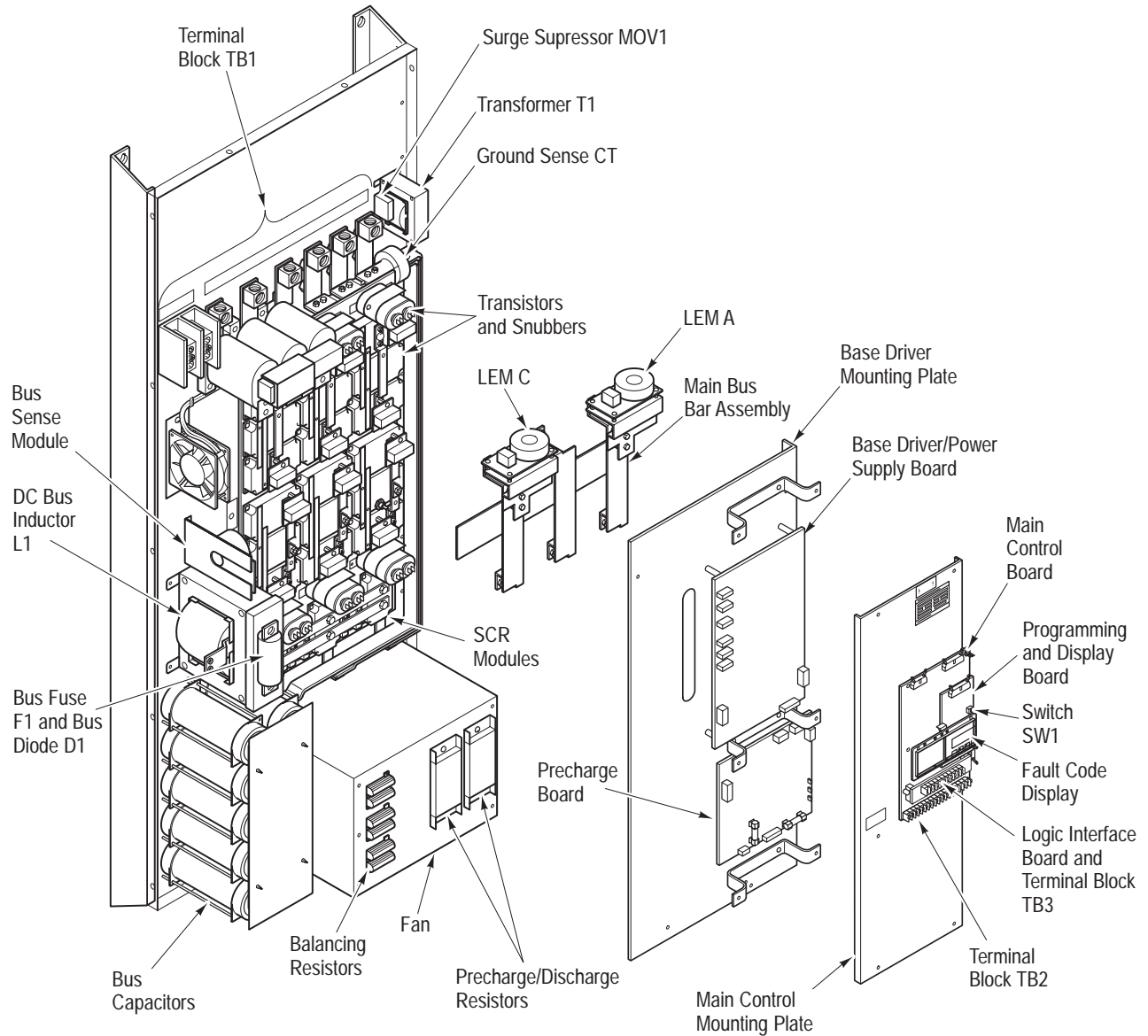

AB0153A

Logic Interface Options

The following logic interface conventions for Logic Interface Boards 1336-MOD-L1, -L2, and -L3 will help you avoid controller hangups and error loops.

The 1336 Logic Interface Board is located on the Main Control Board, below the Programming and Display Board. This interface, labeled TB3, connects to Connectors J8 and J9 on the Main Control Board.

1336-MOD-L1 Logic Interface Options

Figure 1.2
 Three-Wire Start/Stop

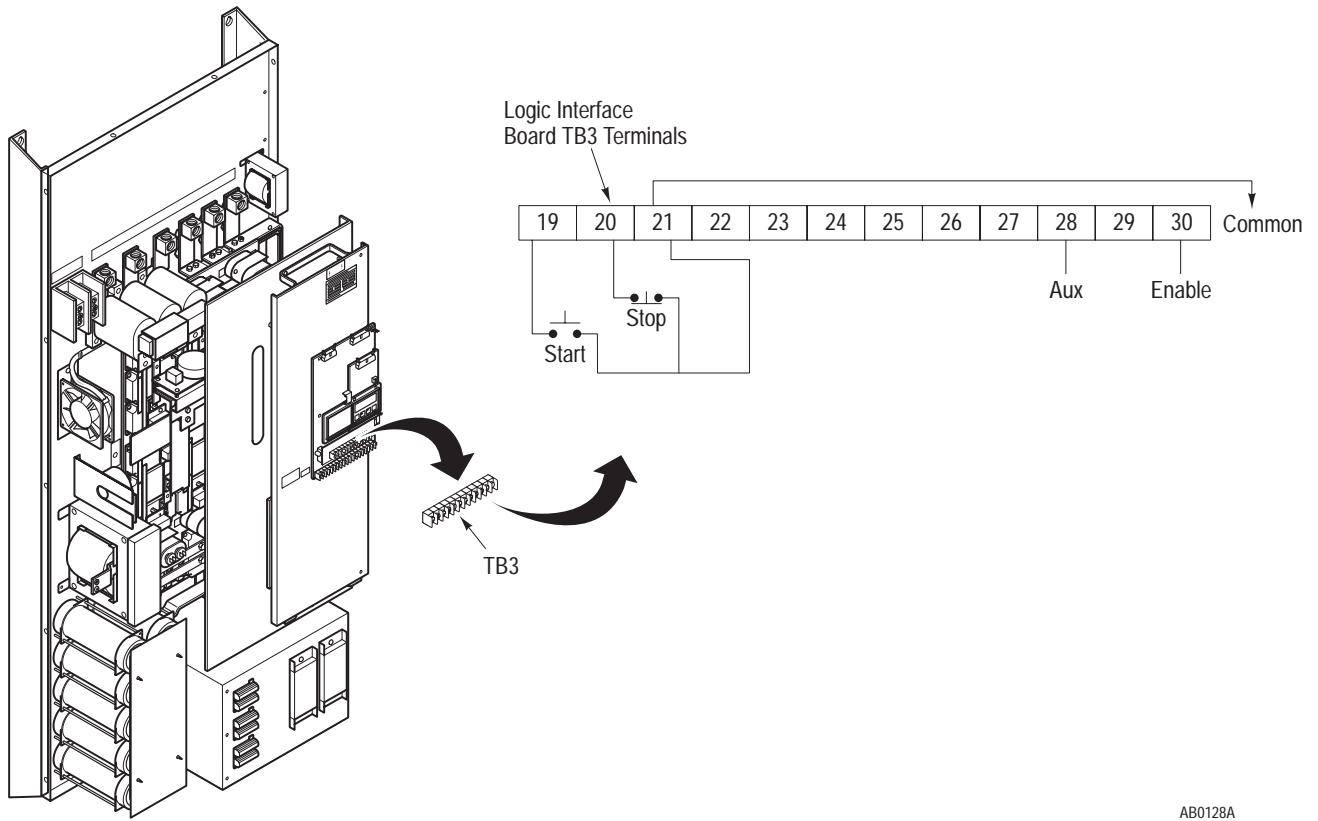

IMPORTANT: AUX and Enable inputs must be true before the drive can be started.

Figure 1.3
 Two-Wire Start/Stop

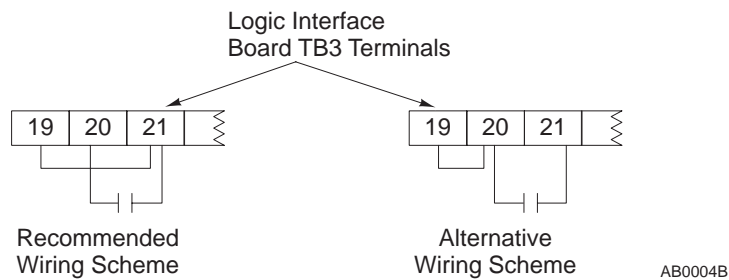

NOTE: You can clear a fault by pressing the Start/Stop button. This works if:

1. Parameter 14 is set to 1.
2. Parameter 39 is set to 1.

If Parameter 14 is not set to 1, or if an other wiring scheme is used, the drive can get stuck in an Operator Error F11 Fault Code loop. Refer to the description of Parameters 14 and 39 in the 1336 Programming Manual.

1336-MOD-L2 and -L3 Logic Interface Options

Figure 1.4
Three-Wire Start/Stop

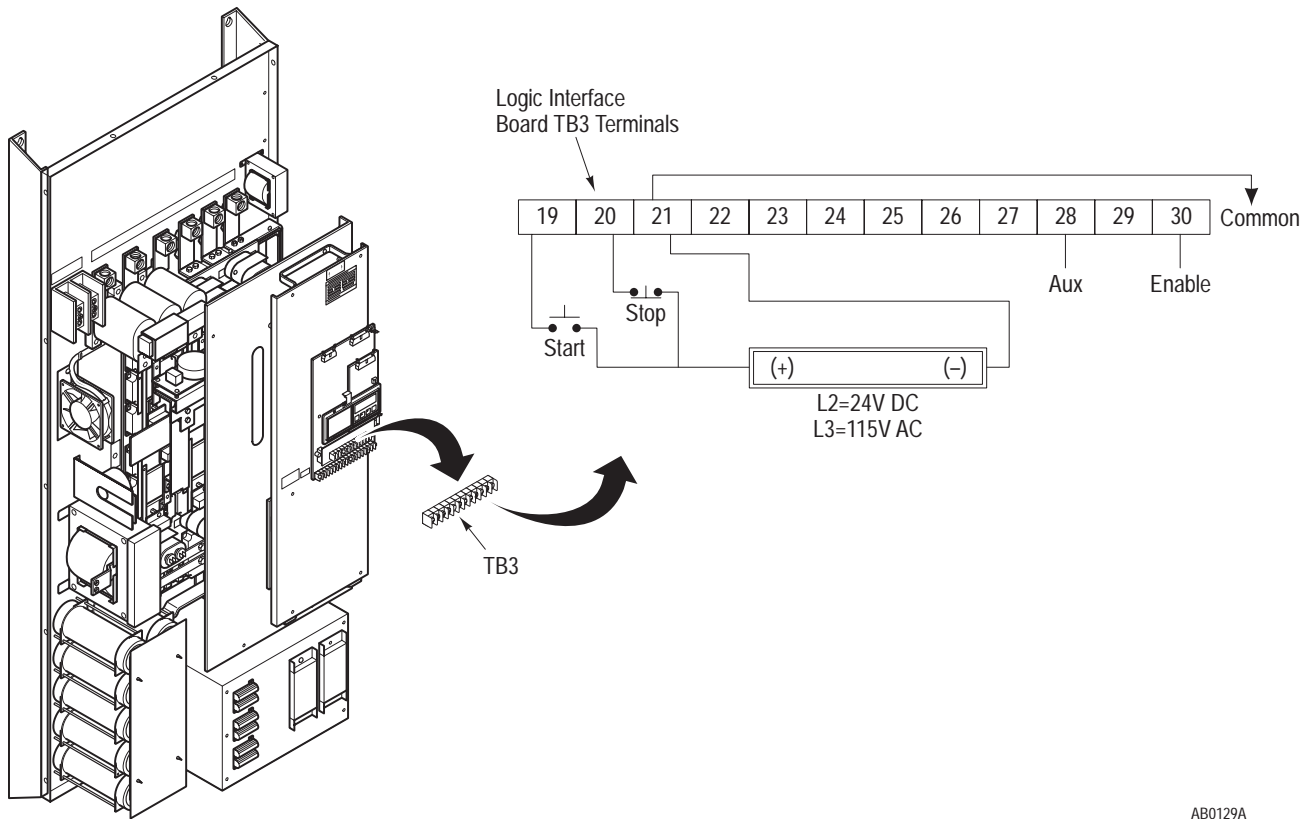

AB0129A

IMPORTANT: AUX and Enable inputs must be true before the drive can be started.

Figure 1.5
Two-Wire Start/Stop

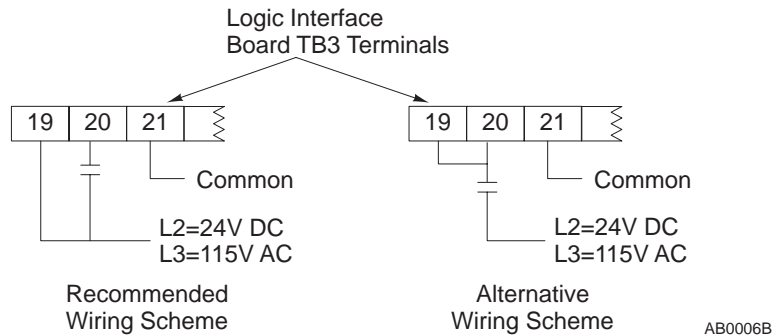

NOTE: You can clear a fault by pressing the Start/Stop button. This works if:

1. Parameter 14 is set to 1.
2. Parameter 39 is set to 1.

If Parameter 14 is not set to 1, or if an other wiring scheme is used, the drive can get stuck in an Operator Error F11 Fault Code loop. Refer to the description of Parameters 14 and 39 in the 1336 Programming Manual.

Basic Drive Control and Fault Display

Diagnostic procedures refer to **both** program panel and optional local control panel. The following information on operation is also located in the Hardware Manual and Programming Manual. It is provided here for your convenience during troubleshooting.

Local Programming

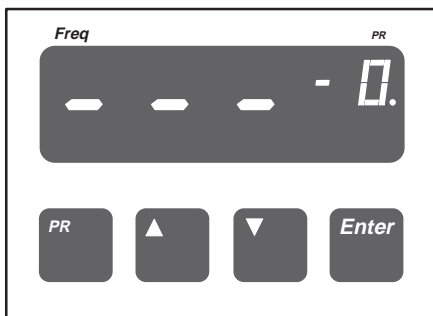

Four pushbuttons on the Local Display and Programming Panel are used for both viewing and programming parameters. Parameters may be viewed while the drive is running, but not changed.

A decimal point displayed in the far right corner indicates that the programming mode was selected and the enter button was pressed. Parameter values may be changed if the decimal is present.



The PR pushbutton is used to switch from the operating display to the parameter viewing display. Once in the viewing display, the PR pushbutton is used to increment through the parameters.

Enter

The Enter pushbutton is used to switch from viewing to programming but only when Parameter 0 is displayed, and only if switch SW1 is set to allow parameter programming. When programming parameters, the Enter pushbutton is also used to store the displayed value.



These buttons are only functional in the programming mode. When programming parameters, the increment and decrement pushbuttons are used to scroll up or down to the parameter value to be entered. Pressing both buttons simultaneously will end programming and return the drive to the operating display.

After exiting the programming mode, the stop command must be cycled to reset the drive and confirm that programming is complete. Failure to follow these instructions will result in a F11 operator error fault.

SW1 Operation

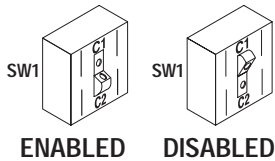

SW1 is a switch on the Local Display and Programming Panel that can be accessed only with the drive cover removed. This rocker switch may be used to disable the Enter pushbutton and control access to drive programming.

Enter

Enter button enabled — Access to programming allowed if SW1 is set to position C1.

Enter

Enter button disabled — Access to programming not allowed if SW1 is set to position C2.

Operation

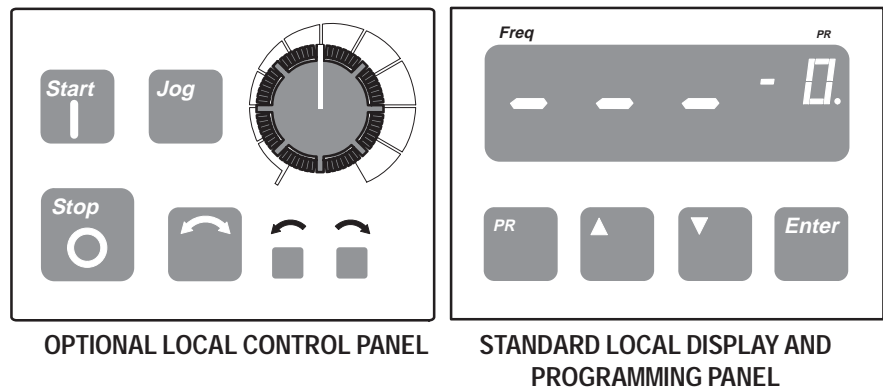

The Local Display and Programming Panel is supplied on all drives as standard.

The Local Control Panel is an optional feature. It may be installed at the factory or added in the field at a later date. If the Local Control Panel is not specified when the drive is ordered, a blank plate will be installed in its place.

IMPORTANT: The 1336 Local Control Panel is not intended to replace or be considered a suitable alternative for the Operator Control Station for all applications. Refer to codes and standards applicable to your particular system for specific requirements and additional information.

Drive Restart

IMPORTANT: The 1336 drive is programmed to avoid responding to unintentional start commands. The stop input to the drive must first be false, then returned to true to restart the drive:

- When exiting programming at the Local Programming and Display Panel.
- After a power-on reset fault has occurred, if Parameter 14 is set to **0**.
 - F01 power-on reset is displayed when power is first applied to the drive and when a fault is cleared.
 - If Parameter 14 is set to **1**, cycling a stop input is not required after reapplying power or clearing a fault.

If this sequence is not followed, the drive will fault and display F11.

When Parameter 14 is set to 0, the stop command must be repeated twice, once to clear the fault, then again to reset drive logic once the fault has been cleared.

A stop input is any valid stop signal that the drive receives. Valid stop inputs are:

- The Stop pushbutton on the Local Control Panel — As shown on the following page.
- The stop input wired to TB3 at Terminal 20 — As explained in Appendix A, Logic Interface Options.
- When serial communications is used, writing to Parameter 51 to clear the fault, then setting the stop bit of the serial input control word in Parameter 57 — As explained in the 1336 Programming Manual.

Optional Local Control Panel

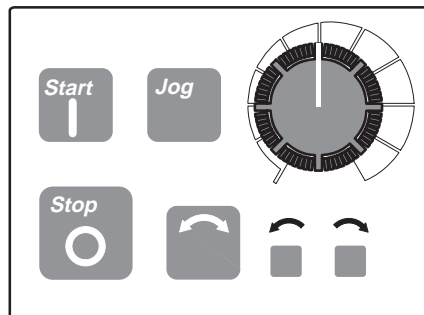

IMPORTANT: The local Stop pushbutton remains operational when remote stop devices are used. However, drive parameter settings determine whether other operator elements will be functional or non-functional.

To allow local control:

- The local Start pushbutton requires that Parameter 21 be set to on **1**.
- The local Jog pushbutton requires that Parameter 23 be set to on **1**.
- The direction pushbutton requires that Parameter 22 be set to on **1**.
- The local speed potentiometer is dependent upon the programming of Parameters 5 and 6 and the status of speed select. Speed select is controlled by TB3, Terminal 27 or serial programming. Refer to Chapter 8 — Speed Selection for additional details.



Pressing the Start pushbutton will initiate drive operation and accelerate the drive to the selected speed if:

Parameter 21 is set to on **1**.



The Stop pushbutton remains operational when remote stop devices are used. Pressing the stop pushbutton will initiate the stop sequence and the drive will cause the motor to:

- Coast-to-stop if Parameter 10 is set to **0**.
- Brake-to-stop by DC injection if Parameter 10 is set to **1**.
- Ramp-to-stop if Parameter 10 is set to **2**.

If the drive has stopped due to a fault, pressing the Stop pushbutton will only clear the display and reset the drive, not correct the fault.



Pressing the Jog pushbutton will jog the drive if:

Parameter 23 is set to (on) **1**.



Pressing the direction pushbutton will cause the motor to ramp down to zero, then ramp up to set speed in the opposite direction if:

Parameter 22 is set to (on) **1**.



When power is applied to the drive, one of these two lights will be lit to indicate the selected direction of motor rotation.

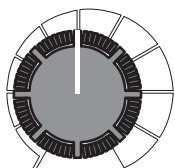

Turning the speed potentiometer will adjust or set drive output frequency if the speed pot has been selected and is functional.

Standard Local Display and Programming Panel

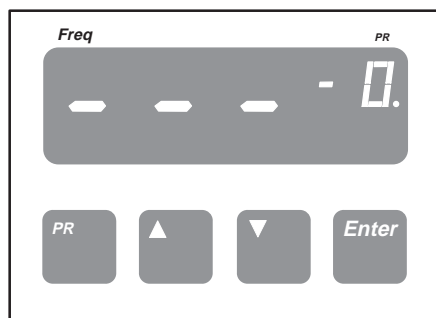

The Local Display and Programming Panel provides a means of displaying different drive status conditions while providing pushbutton control for selected viewing and parameter programming. The panel is provided as standard and is a permanent part of the drive.

The Freq display is a three character display that shows:

Standby Status Display

The standby status of the drive when it is waiting for a drive start or jog command.

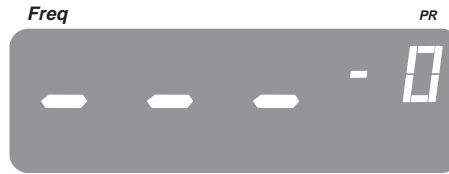

Output Frequency Display

The drive output frequency appears when the drive is running.



Fault Display

Fault codes appear if the drive detects a fault condition.



Parameter Programming Display

Parameter values appear when viewing or programming drive parameters.



Operating Display

The Pr display is a two character display that shows the frequency source when the drive is in Standby, Jog or Running.

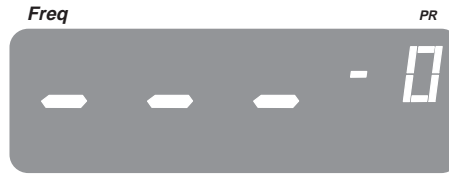

- | | |
|-----------------------|----------------------------|
| - 0 Local speed pot | - 5 Remote speed pot input |
| - 1 0 to +10V input | - 6 Jog selected |
| - 2 4-20 mA input | - 7 Preset Speed 1 |
| - 3 Pulse train input | - 8 Preset Speed 2 |
| - 4 Serial input | - 9 Preset Speed 3 |

IMPORTANT: No dash indicates a parameter number rather than a frequency source (above).

Parameter Viewing Display

The parameter number appears when viewing parameters.



Parameter Programming

A decimal point appears if parameter programming has been selected and is allowed. If the programming function is locked out, check switch SW1 on the Local Display and Programming Panel Card. The switch must be set to C1 to allow parameter programming.



Fault Display

Two dashes appear if a fault has occurred.



Special Display — Enable Loss

All dashes appear if an enable loss has occurred.

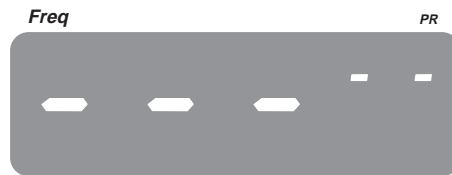

Fault Code Descriptions

The following table describes each Fault Code. Fault Codes appear on the drive's Programming and Display Board. The following table lists the Fault Codes and describes appropriate checks or repair actions for each code. Some of the descriptions and recommended actions mention Parameters. Refer to the 1336 Programming Manual for Parameter descriptions.

Clearing Faults

After correcting a fault, you can clear a fault from the drive in one of two ways:

1. Cycle the input power to the drive.
2. Press the Stop button. This works only if Parameter 39 is set to 1. Refer to Parameter 39 – Fault Clear in the 1336 Programming Manual.

Table 1.A
 1336 Fault Codes

Display	Description	Recommended Action
----	Special Display. The Enable Interlock is Open.	<p>Check the following:</p> <ol style="list-style-type: none"> 1. Main Control Board connector J9 for a jumper on pins #7 and #8 if a Logic Interface Board is not used. 2. TB3, Terminal #30 is missing the proper signal for the Logic Interface Board. MOD-L1 is a contact closure only; -L2 is 24V DC; -L3 is 115V AC. 3. Use a hand-held terminal to check Parameter 59, Bit #1. 0 equals Disabled, 1 equals Enabled. The displayed value of Bit #1 depends on the state of TB3, Terminal #30. 4. If the jumper is present at connector J9, pins #7 and #8, and Parameter 59, Bit #1 is 0, replace the jumper and/or the Main Control Board. 5. If the correct signal is present at TB3, Terminal #30 and if Parameter 59, Bit #1 is 0, replace the Logic Interface Board and/or the Main Control Board.
F01	Special Display. This is not a Fault Code. The drive displays this code each time it is powered up or when you clear a fault.	Take no action. The drive is in a diagnostic mode when this code appears.
F02	Auxiliary Fault. The Auxiliary Interlock is open.	<p>Check the following:</p> <ol style="list-style-type: none"> 1. Main Control Board Connector J9 for jumper on pins #9 and #10 if a Logic Interface Board is not used. 2. TB3, Terminal #28 is false: MOD-L1, contact is not closed; -L2, 24V DC is not present; -L3, 115V AC is not present. 3. Use a hand-held terminal to check Parameter 55, Bit #1. 0 equals Off, 1 equals On. Bit #1 should display 1. 4. If a jumper is present at Connector J9, pins #9 and #10, and Parameter 55, Bit #1 is 0, replace the jumper if the connections are faulty, or replace the Main Control Board if the jumper connections are good. 5. If the correct signal is present at TB3, Terminal #28, and Parameter 55, Bit #1 is 0, replace the Logic Interface Board and/or the Main Control Board.
F03	Input Power Loss. This fault occurs when Parameter 40 is set to 0 and input power is interrupted for 0.5 second.	Monitor the incoming AC line at TB1 Terminals L1, L2 and L3 for low voltage or line power interruption. Check for differences in the Base Driver Board Firmware revision. Firmware revision 1.01 is 380V AC, -10%. Firmware revision 1.11 or higher is 380V AC, -15%.
F04	Bus Undervoltage. The DC bus dropped below 456V DC for Firmware revision 1.01 or 338V DC for Firmware revision 1.11 software on the Base Driver Board. 485V DC for "C" ratings.	Check the incoming line voltage for correct voltage. Check voltage at the TB1, Terminals +DC and -DC. The voltage is monitored on the Base Driver Board.

Table 1.A
1336 Fault Codes (continued)

Display	Description	Recommended Action																								
F05	Bus Overvoltage. This fault occurs when the DC bus has risen above 810V DC for "B" ratings. 975 V DC for "C" ratings.	<p>Check the following:</p> <ol style="list-style-type: none"> Incoming line voltage for excessive voltage or transient conditions. (A Line Analyzer may be required.) Excessive motor regeneration due to high inertia load or excessive speed in the deceleration ramp. An extended deceleration ramp or dynamic braking may be required. Voltage at TB1 Terminals +DC and -DC. The Base Driver Board monitors bus voltage. <table border="1" style="margin-left: auto; margin-right: auto;"> <caption>Nominal Readings</caption> <thead> <tr> <th>Rating</th> <th>Input Volts</th> <th>DC Bus</th> <th>Rating</th> <th>Input Volts</th> <th>DC Bus</th> </tr> </thead> <tbody> <tr> <td></td> <td>380</td> <td>535</td> <td></td> <td>500</td> <td>700</td> </tr> <tr> <td>"B"</td> <td>415</td> <td>580</td> <td>"C"</td> <td>575</td> <td>800</td> </tr> <tr> <td></td> <td>460</td> <td>650</td> <td></td> <td>600</td> <td>850</td> </tr> </tbody> </table>	Rating	Input Volts	DC Bus	Rating	Input Volts	DC Bus		380	535		500	700	"B"	415	580	"C"	575	800		460	650		600	850
Rating	Input Volts	DC Bus	Rating	Input Volts	DC Bus																					
	380	535		500	700																					
"B"	415	580	"C"	575	800																					
	460	650		600	850																					
F06	<p>Motor Stalled. The drive was unable to change frequency for 10 seconds with Firmware revision 1.01, or 4 seconds with Firmware revision 1.11 or higher (base driver). Probable causes include:</p> <ol style="list-style-type: none"> Excessive current. The motor is drawing over 150% of the drive rating and the motor load will not allow the drive to accelerate to set speed. Bus voltage rise. A 10% rise in bus voltage above the nominal value has occurred. A regeneration condition will not allow the drive to decelerate. The Boost setting is improper. If too low, the motor will not develop enough torque to "break away" the load. If too high, saturation of the motor winding may occur. 	<ol style="list-style-type: none"> A longer acceleration ramp or reduced load may be required. A longer deceleration time or dynamic braking may be required. Check Parameters 9 and 48. Refer to the 1336 Programming Manual. 																								
F07	Motor Overload. The output current has exceeded the percentage of current set by Parameter 38, Electronic Thermal Overload.	Check for load jams, seized bearings, machinery jams, and problems with the motor or couplings.																								
F08	<p>Overtemperature. The drive has detected an over temperature/open thermal switch on the drive's heat sink. Possible causes:</p> <ol style="list-style-type: none"> 1005C at the thermal switch, located on the back plane of the drive. Blocked or dirty heat sink cooling fins. Faulty cooling fan on B010 or C015 units, or larger units. The Thermal Switch connection at Main Control Board Connector J6 is faulty (gray and white wires). 	<ol style="list-style-type: none"> Correct a heavy load on the motor. Cool down the room temperature in which the drive is operating. Use a soft brush or air pressure to remove dust from the cooling fins. Check the fan for jams or broken fan blades. Make sure the fan is operating. Make sure the Thermal Switch is plugged in. Check for an open switch. Check the connector pins at the Main Control Board. Remove the white cap from the orange J6 connector (female) and check that the wires in the connector contact the leads in the connector. 																								

Table 1.A
1336 Fault Codes (continued)

Display	Description	Recommended Action
F09	<p>Pot Return Open. The remote speed pot is being used to control the drive frequency after the low input opens, but while the wiper and high inputs are still connected. Depending on the Main Control Board Firmware revision number, the following occurs:</p> <ol style="list-style-type: none"> 1. Revision 1.01. The Fault Code does not display, but the symptoms appear. The drive will default to the Parameter 19 maximum frequency setting. An open or disconnected wire defaults the drive to the maximum frequency command. 2. Revision 1.10 or higher/later. The Fault Code displays. 	<p>Verify the wire connections. Check the resistance of the speed pot to reveal bad internal connections. Check the wiring between the speed pot and the board for continuity.</p>
F10	<p>Serial Time Out. This code indicates a break in communications after communication has been established between the MOD-G2 Remote I/O Board. Operator Error.</p>	<ol style="list-style-type: none"> 1. Check the ribbon cable between the drive and MOD-G2 Board. 2. Check Fuse F1, located on the Main Control Board behind the Local Display and Programming Panel. If the fuse is open, the Logic Power of the Control Board has drawn excessive current. Replace the fuse with a 0.5 amp/250 volt Fast-Acting 5 x 20 mm fuse.
F11	<p>Operator Error.</p>	<p>Check the following for incompatible Parameters:</p> <ol style="list-style-type: none"> 1. Control Board Firmware revision 1.01: <ol style="list-style-type: none"> a. Parameter 20 equals or is greater than Parameter 18. b. Parameter 18 equals or is greater than Parameter 50. c. Parameter 50 equals or is greater than Parameter 48. 2. Control Board Firmware revision 1.10: <ol style="list-style-type: none"> a. If Parameter 41 is set to a value of 2, set Parameter 10 to either 0 or 2. b. If Parameter 42 is set to a value of 0, set Parameter 41 to either 1 or 2. c. On Power Up, or after exiting the Program mode, press the Stop button before a Start. If Parameter 14 is set to 0 and power is applied to the drive, or when a fault occurs, press the Stop button twice; one press clears the fault, and the second press resets the Not Stop Bit. 3. For Fault Clear procedures, refer to the Parameter 39 description in the 1336 Programming Manual.
F12	<p>Overcurrent. The drive has exceeded 180% of its current rating. This fault is a hardware limitation of the drive.</p>	<p>Check the following:</p> <ol style="list-style-type: none"> 1. A short circuit at the output of the drive. 2. An excessive load on the motor. 3. Parameter 9 or 48 (DC boost) is set too high. 4. Parameter 43, Dwell Frequency, is set too high. Refer to the 1336 Programming Manual.
F13	<p>Ground Fault. One or more of the drive output terminals is grounded.</p>	<p>Check the motor and external wiring to the drive output terminals for a grounded condition.</p>
F14	<p>Output Short. Two or more of the drive output terminals are short circuited between the terminals.</p>	<p>Check all three phases of the motor and external wiring for a grounded condition.</p>
F15	<p>Refer to Fault Code F14.</p>	<p>Refer to Fault Code F14.</p>
F16	<p>Refer to Fault Code F14.</p>	<p>Refer to Fault Code F14.</p>
F17	<p>Transistor Short. A shorted drive transistor, either positive or negative, is detected.</p>	<p>Refer to Test 3 – Testing the Transistor Modules in the Component Electrical Tests section of this manual.</p>

Table 1.A
1336 Fault Codes (continued)

Display	Description	Recommended Action
F18	Refer to Fault Code F17.	Refer to Fault Code F17.
F19	Precharge Open. The precharge circuit does not allow precharge to occur. This Fault Code does not display for drives using Firmware revision 1.01, but the symptoms appear.	Test the Precharge Circuit. Refer to Test 5 – Testing Precharge SCR M1 and Test 4 – Testing the Precharge Board in the Component Electrical Tests section of this manual.
F20	Drive Hardware. A fault on the Base Driver ASIC (U14) cannot be cleared. The transistors are disabled when the drive is malfunctioned.	Clear the fault. If you cannot clear the fault, replace the Base Driver Board.
F21	Drive Hardware. The PWM algorithm in the Base Driver Board processor has been disrupted.	If the fault occurs repeatedly, replace the Base Driver Board.
F22	Drive Software. The Base Driver Board processor has been reset. The most likely causes: 1. Power supply voltage has dropped below 4.55V, causing a reset. 2. Electrical noise at the reset input of the processor. 3. Loose connection on the DC bus causing noise.	Clear the fault. If you cannot clear the fault, replace the Base Driver Board.
F23	Drive Software. The main loop of the Main Control Board microprocessor is taking more than 10 ms to complete.	Clear the fault. If you cannot clear the fault, replace the Base Driver Board.
F24	Drive Software. The Base Driver Board microprocessor has an undefined value in a RAM location.	Clear the fault. Replace the Base Driver Board if the fault occurs often.
F25	Drive Software. The commanded frequency is out of range.	Clear the fault. If you cannot clear the fault, replace the Base Driver Board.
F26	Drive Software. The Base Driver Board microprocessor has an undefined value in a RAM location.	Clear the fault. Replace the Base Driver Board if the fault occurs often.
F27	Drive Software. The processor has stopped sending PWM signals to the ASIC, disabling the transistors and setting the fault.	Clear the fault. If you cannot clear the fault, replace the Base Driver Board.
F28	Drive Software. The Base Driver Board has not received communication from the Main Control Board for over 100 ms.	Check ribbon cable between the Main Control Board and the Base Driver Board. Replace the Main Control Board and/or the Base Driver Board.
F29	Input Software. The Drive cannot find a legal frequency at which to operate due to the programming of the Parameters. This fault is set on the Main Control Board and may be tripped as Fault Code F11.	Refer to the Fault Code F11 description in this table. Clear the fault. If you cannot clear the fault, replace the Base Driver Board.

Table 1.A
1336 Fault Codes (continued)

Display	Description	Recommended Action
F30	Input Software. The Base Driver Board cannot identify a valid frequency source.	Clear the fault. If you cannot clear the fault, replace the Base Driver Board.
F31	Input Software. The Base Driver Board does not respond to communications on the Main Control Board.	When F31 fault is displayed, the communication between the Main Control Board and Base Driver Board has not been established. If you attempt a fault reset before the communication is established, an F32 Fault occurs. Check the ribbon cables and connections between the Base Driver Board and the Main Control Board. Replace one or more of the following: <ol style="list-style-type: none"> 1. Base Driver Board. 2. Ribbon cable. 3. Main Control Board.
F32	EEPROM Error. The EEPROM reads an out-of-range Parameter.	Clear the fault. If you cannot clear the fault, replace the Main Control Board.
1336 Fault Codes for Drives with Firmware Rev. 2.01		
F33	Retries Exceeded	Refer to Fault Buffers (Parameters 86 – 89) to determine the cause of failure.
F34	Boost Error	Parameter 83 must be set to a value less than or equal to Parameter 48.
F35	Negative Slope	Check Parameters 18 and 50. Check Parameter 48 and 50. Parameter 18 must be equal to or greater than Parameter 50. Parameter 50 must be equal to or greater than Parameter 48.
F36	Diagnostic Current Limit	Used to detect the drive going into Current Limit. Check for excessive load.
F37	P-Jump Error	P-Jump and Slip Compensation cannot be used together. Check Parameters 42, 78 – 80 for correct settings.

Diagnostic Procedures by Symptom

The following flowcharts apply to drives rated B150 – B200, C150 – C200, and VT B200 – B250. The flowchart lists drive symptoms, symptom descriptions, and recommended actions to remedy the symptoms.

No Display

Check for illumination of Bus Indicator Light DS1. If illuminated, dangerous voltages are present within the drive.

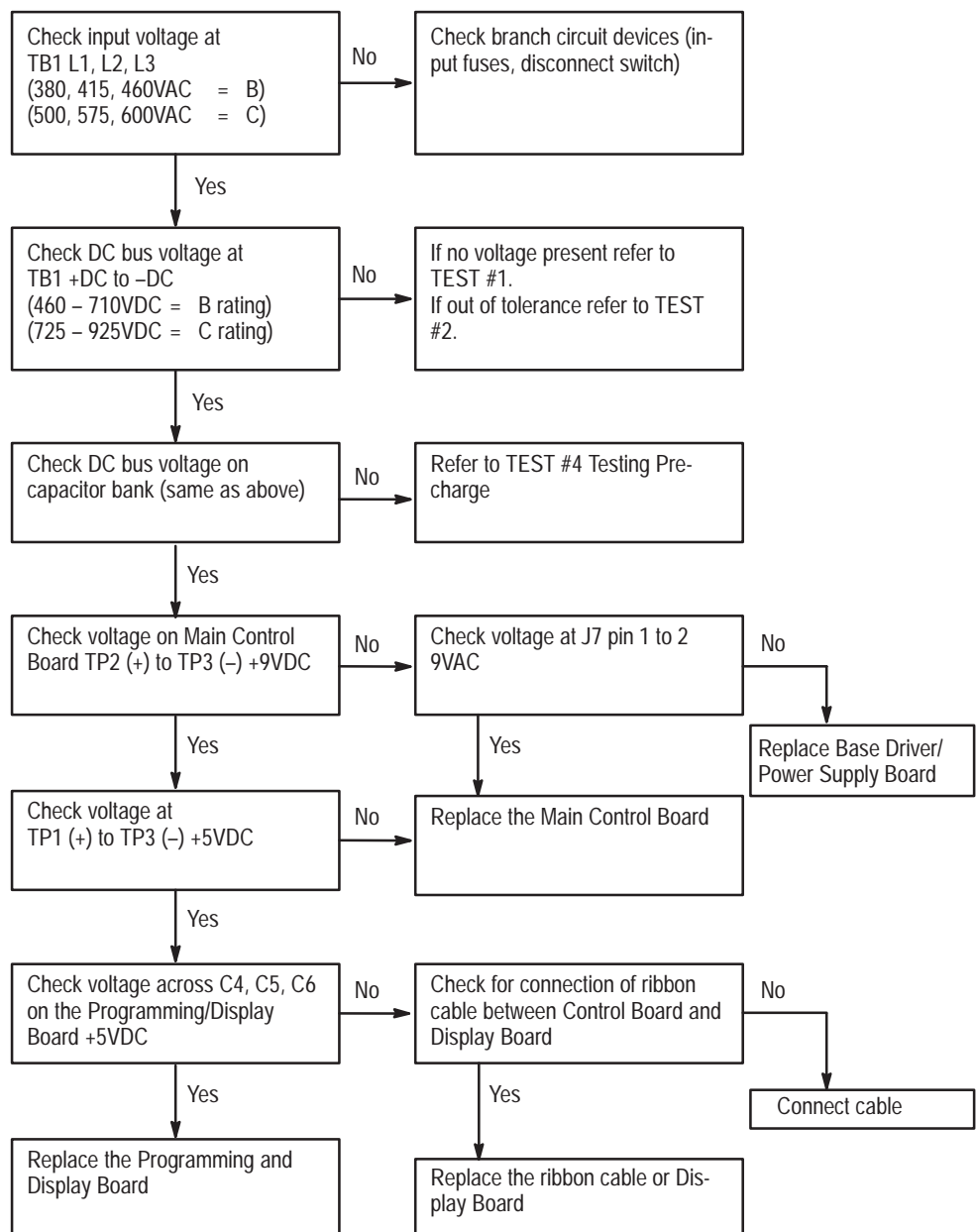

Drive Will Not Start

Local Control Panel (MOD-FA2) used to control drive.

Check the display for a stand-by status (--- 0). The digit tells you what frequency reference the drive will follow.

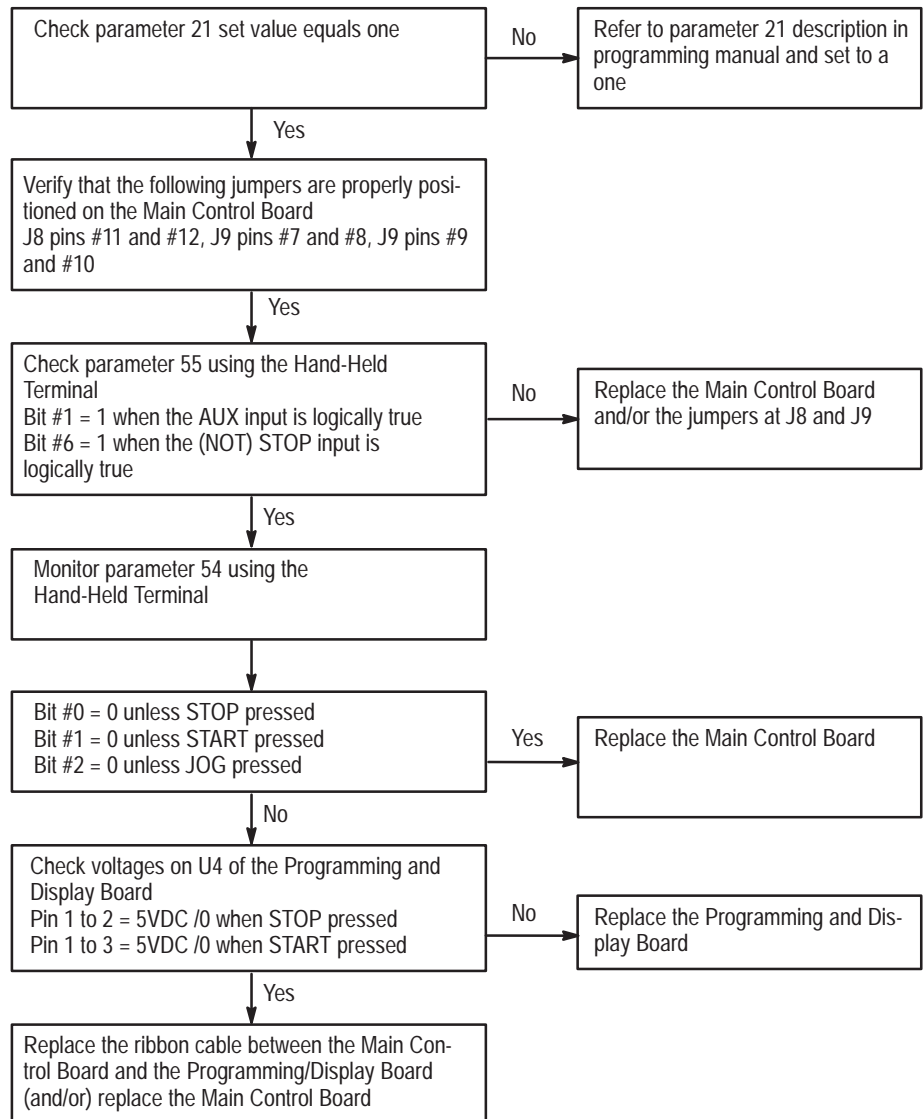

IMPORTANT: If the Base Driver Board has Firmware revision 1.01, Fault Code F09 (Precharge Open) does not display. The START or JOG command will be ignored if the precharge circuit is open. Refer to Test 2 – Testing the Bus Capacitors in the Component Electrical Tests section of this manual.

Drive Will Not Start

Remote start/stop (MOD-L1, L2, L3) used to control drive.

Check the display for a stand-by status (----0). The digit tells you what frequency reference the drive will follow.

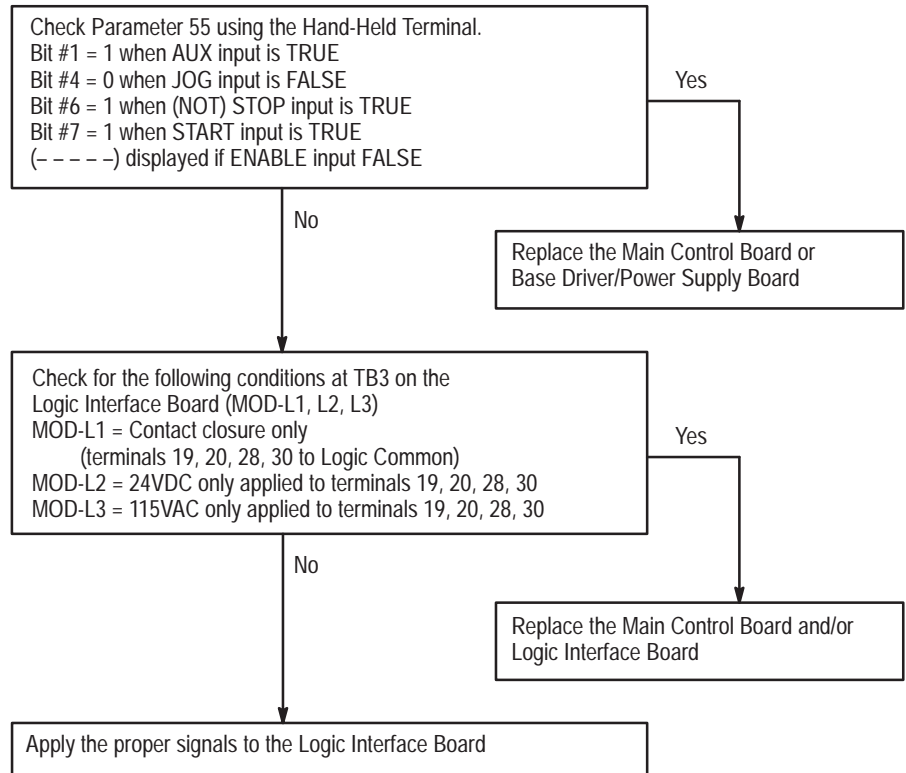

IMPORTANT: If the Base Driver Board has Firmware revision 1.01, Fault Code F09 (Precharge Open) does not display. The START or JOG command will be ignored if the precharge circuit is open. Refer to Test 2 – Testing the Bus Capacitors in the Component Electrical Tests section of this manual.

Drive Will Not Jog

Local Control Panel (MOD-FA2) used to control drive.

The JOG and START commands are mutually exclusive. JOG is not active if a START command is present. START is not active if a JOG command is present.

Check the display for (---6), this display represents a stand-by condition. The 6 is the Frequency Reference for JOG.

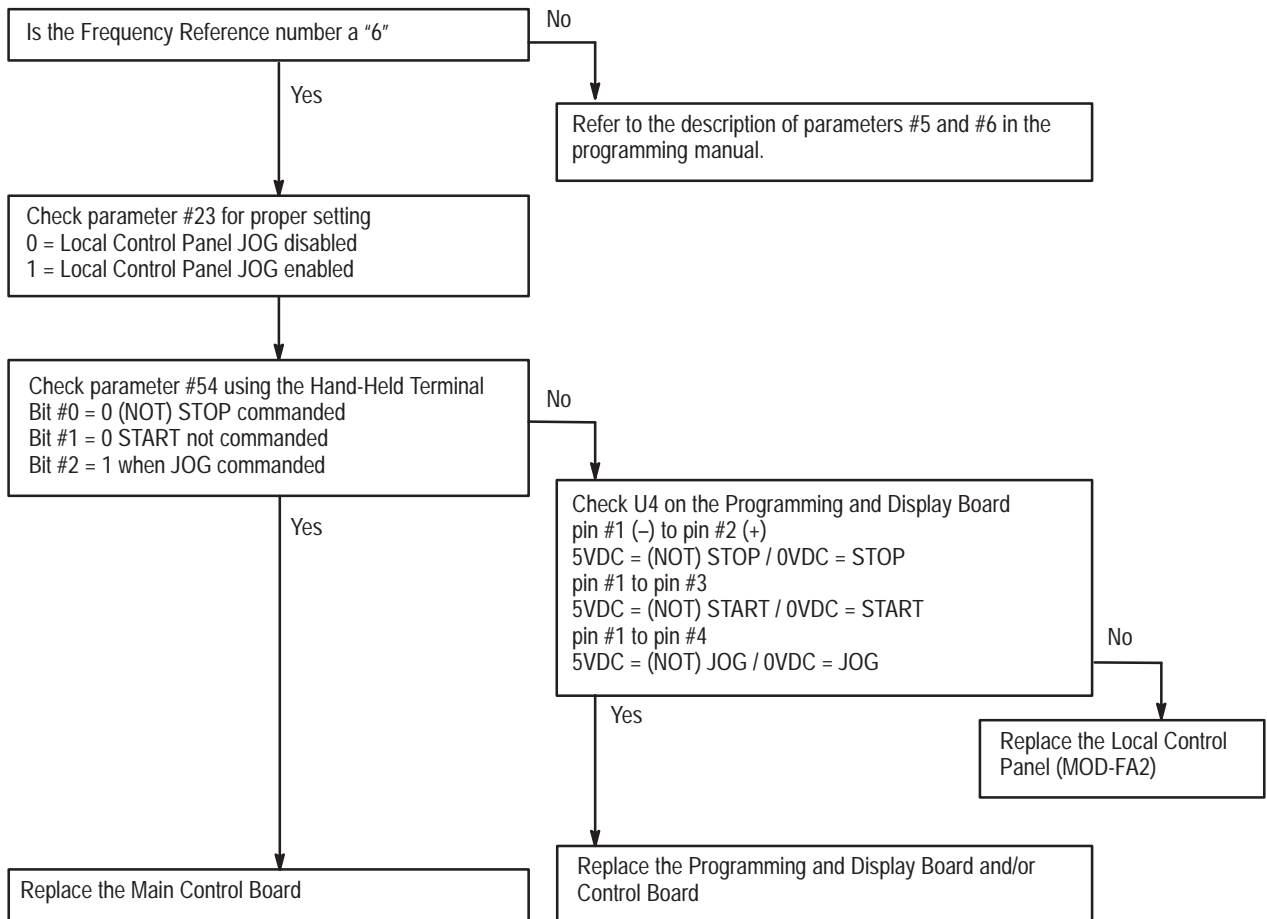

Drive Will Not Jog

Logic Interface Board (MOD-L1, L2, L3) used to control drive.

The JOG and START commands are mutually exclusive. JOG is not active if a START command is present. START is not active if a JOG command is present.

Check the display for a (--- 6), this display represents a stand-by condition. The 6 is the Frequency Reference for JOG.

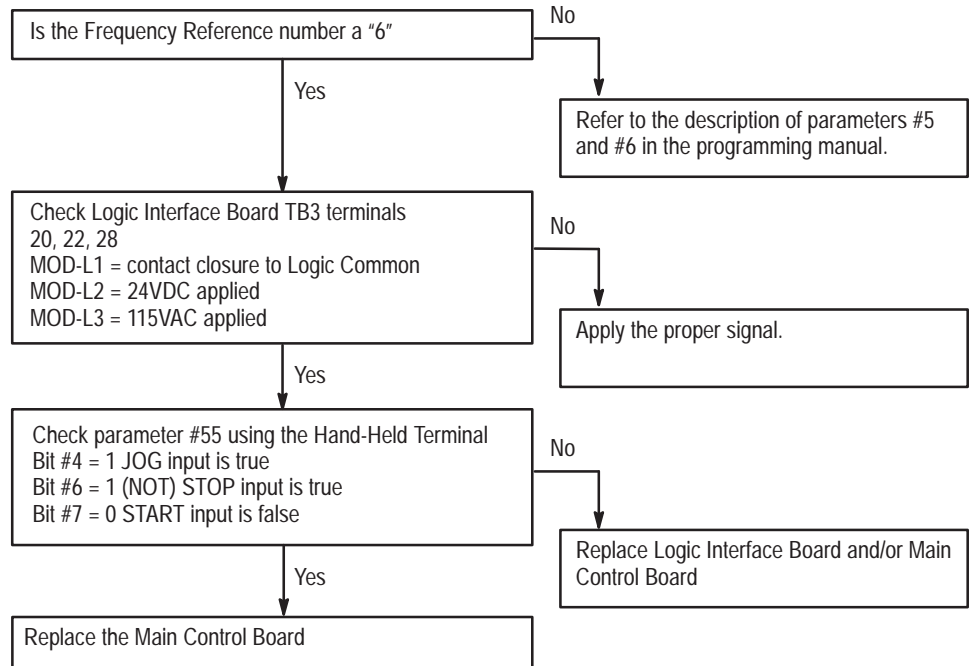

Drive Stays at Zero Hertz When Started

IMPORTANT: Parameter 65 indicates the command frequency, and can be checked using the Hand-Held Terminal.

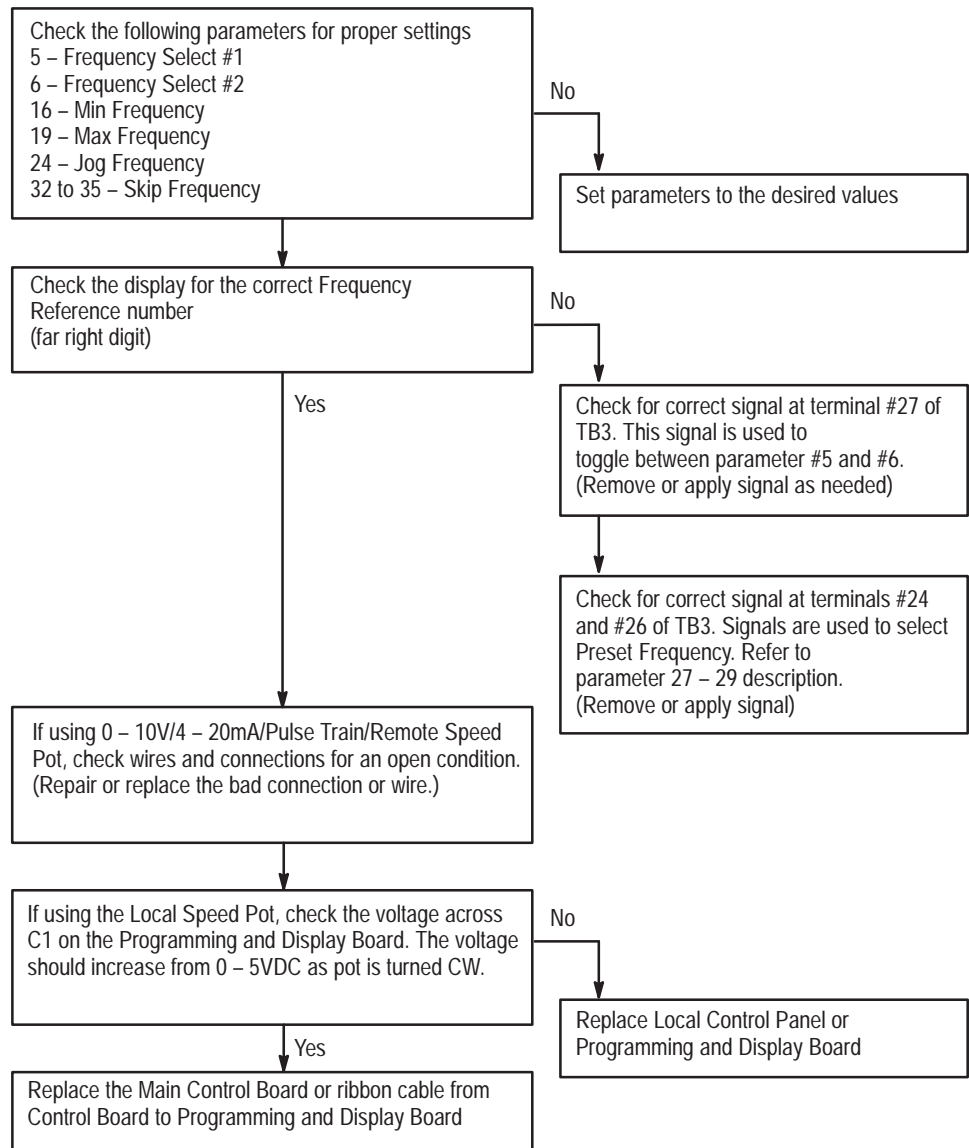

Drive Goes to Max Frequency

IMPORTANT: Parameter 65 indicates the command frequency, and can be checked using the Hand-Held Terminal.

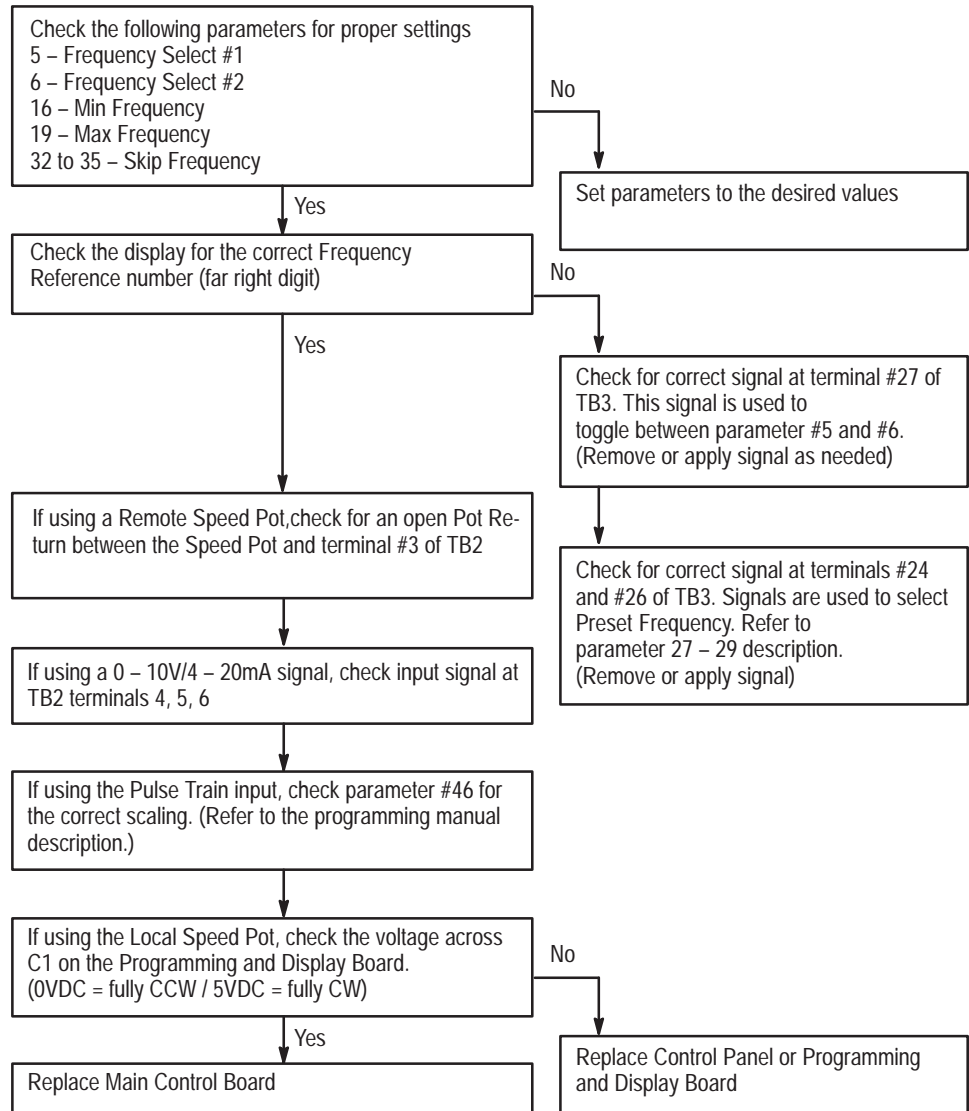

Neon Bus Light Not Illuminated

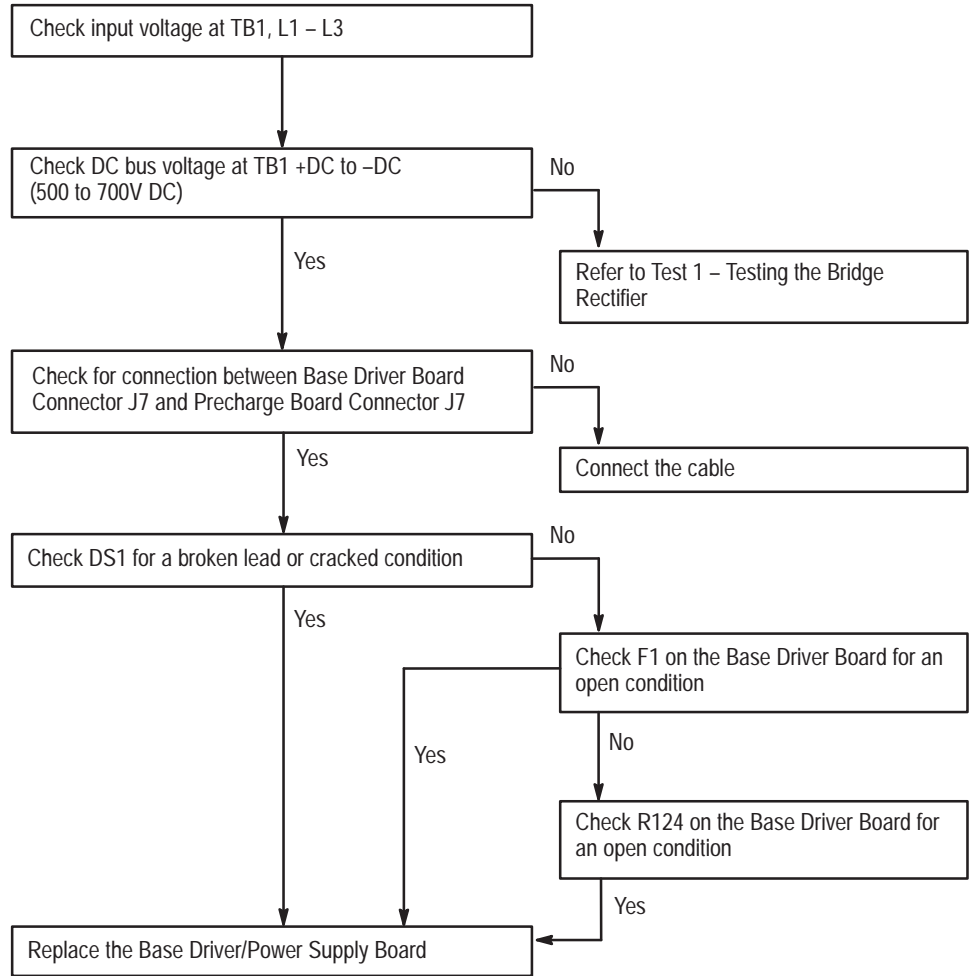

Drive Starts, No Output at M1 – M3

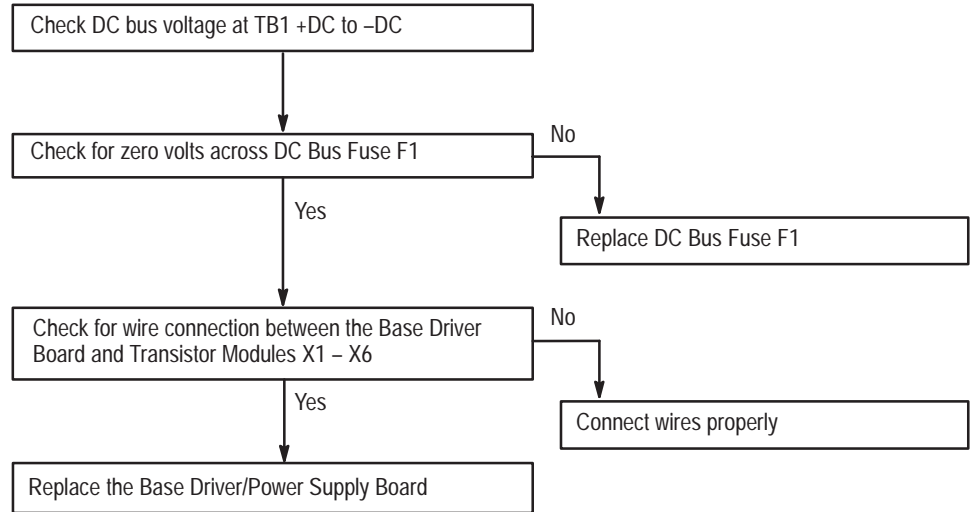

IMPORTANT: An open DC Bus Fuse F1 shows voltage when you measure across the fuse. An open fuse indicates probable transistor malfunction. Check Transistor Modules X1 – X6 following this troubleshooting procedure and before starting the drive.

IMPORTANT: If you disconnect power to the drive and measure the resistance across DC Bus Fuse F1 to check for an open fuse condition, your meter leads must be properly positioned on the fuse. If your meter leads are not properly positioned, Bus Diode D1 is forward biased, and the meter registers a low resistance even if DC Bus Fuse F1 has an open condition.

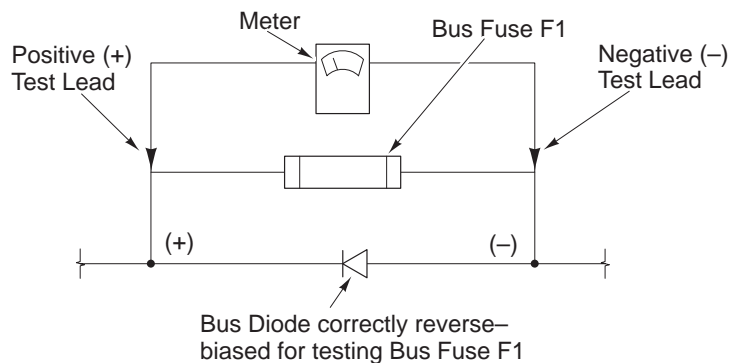

AB0148A

Component Electrical Tests

The following tests help you troubleshoot B150 – B200, C150 – C200, and VT B200 – B250 drives. Double check that the rating on the drive matches the rating for the test you are performing.

Test 1

Testing the Bridge Rectifiers

Bridge Rectifiers SCR1, SCR2, and SCR3 are located on the Main Chassis behind the Base Driver Mounting Plate. These rectifiers are listed in Chapter 4 – Spare Parts List as BR1, BR2, and BR3.

Figure 1.6
Bridge Rectifier Test

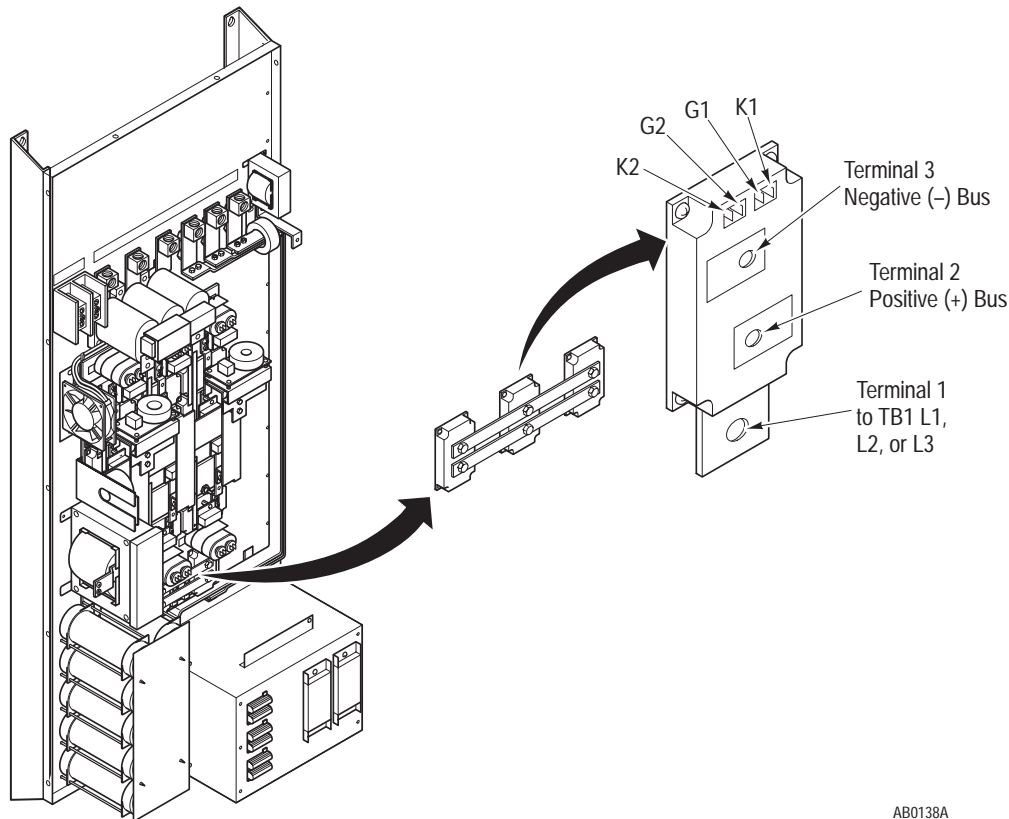

AB0138A



ATTENTION: Disconnect and lock out power from the drive before disassembling the drive. Failure to disconnect power may result in death or serious injury. A bus charge neon indicator provides visual indication that bus voltage is present. Verify bus voltage by measuring the voltage between +DC and –DC on Terminal Block TB1. Do not attempt to service the drive until the neon indicator has extinguished and the bus voltage has discharged to zero volts.

IMPORTANT: Before you remove connections, bus bars, and wires from the drive components, mark the connections, bus bars, and wires to correspond with their component connections and terminals to prevent incorrect wiring during assembly.

1. Remove power from the drive.
2. Wait for Bus Indicator Light DS1 to turn off before proceeding. Check for zero volts at TB1 Terminals +DC and –DC.
3. Remove the Base Driver Mounting Plate from the Drive. Refer to Chapter 2 – Removing the Base Driver Mounting Plate.
4. Remove the wires from the positive (+) and negative (–) rectifier bus bars. The upper bus bar, connecting Terminal 3 on the SCRs, is negative. The lower bus bar, connecting Terminal 2 on the SCRs, is positive.
5. Remove the screws fastening the bus bars to the SCR Terminals 2 and 3.
6. Set your meter to test diodes.
7. Test each of the three bridge rectifiers. The following table shows meter connections and ideal meter readings for those connections. Refer to the former illustration for meter connection locations.

Table 1.B
Bridge Rectifier Test

Meter (+) Lead	Meter (–) Lead	Nominal Meter Reading
1	2	Infinite
3	1	Infinite

8. Attach a 9V DC battery to an SCR:
 - a. Connect the positive battery lead to SCR Terminal G1.
 - b. Connect the negative battery lead to SCR Terminal K1.
9. Set your meter to test diodes and test the SCR. Refer to the following table and former illustration for meter lead and SCR terminal connections.

Table 1.C
Rectifier Test with 9V DC at G1 and K1

Meter (+) Lead	Meter (-) Lead	Nominal Meter Reading
1	2	0.9 Volts

10. Attach a 9V DC battery to an SCR:
 - a. Connect the positive battery lead to SCR Terminal G2.
 - b. Connect the negative battery lead to SCR Terminal K2.
 - c. Test the SCR with your meter set to test diodes. Refer to the following table and former illustration for meter lead and SCR terminal connections.

Table 1.D
Rectifier Test with 9V DC at G2 and K2

Meter (+) Lead	Meter (-) Lead	Nominal Meter Reading
3	1	0.9 Volts

11. Replace any SCR producing readings other than those shown in the previous table. Refer to Chapter 3 – SCR Modules.

Test 2 Testing the Bus Capacitors

The bus capacitors are located on the lower left corner of the Main Chassis. Note differences in Bus Capacitor Bus Bar configurations on 1336 B and C models.

Figure 1.7
B150 – B200 and VT B200 – B250 Bus Capacitor Test

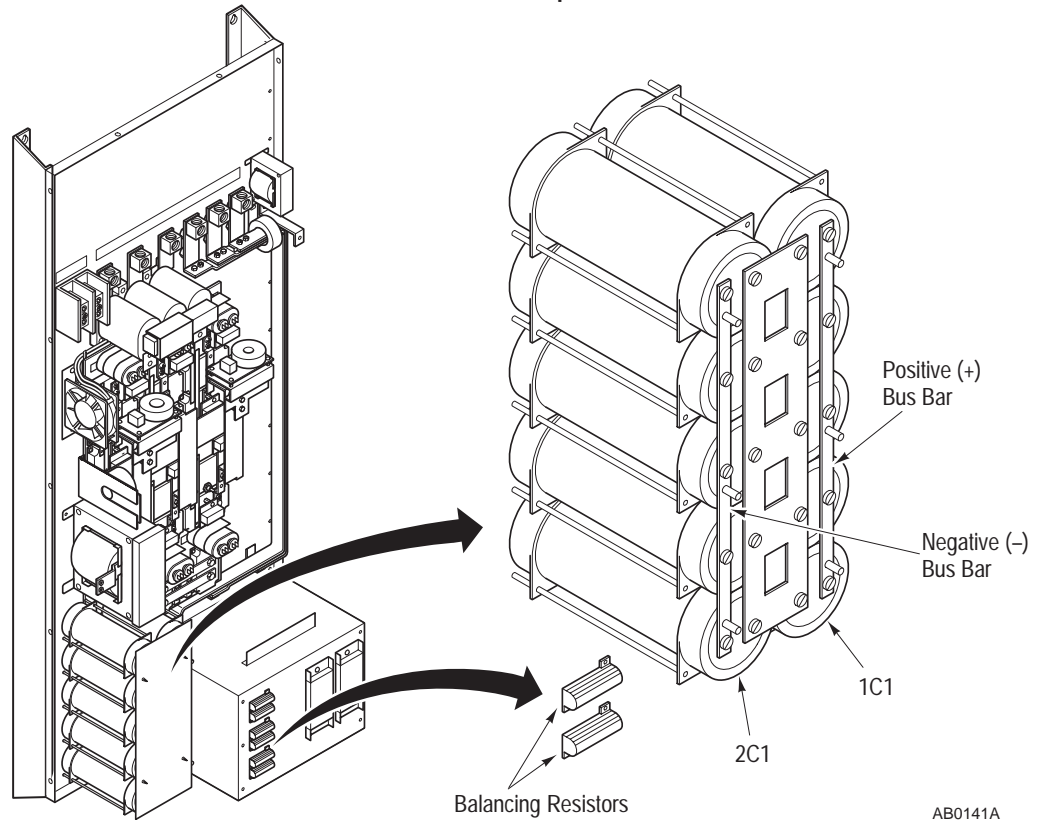

AB0141A

Figure 1.8
C150 – C200 Bus Capacitor Test

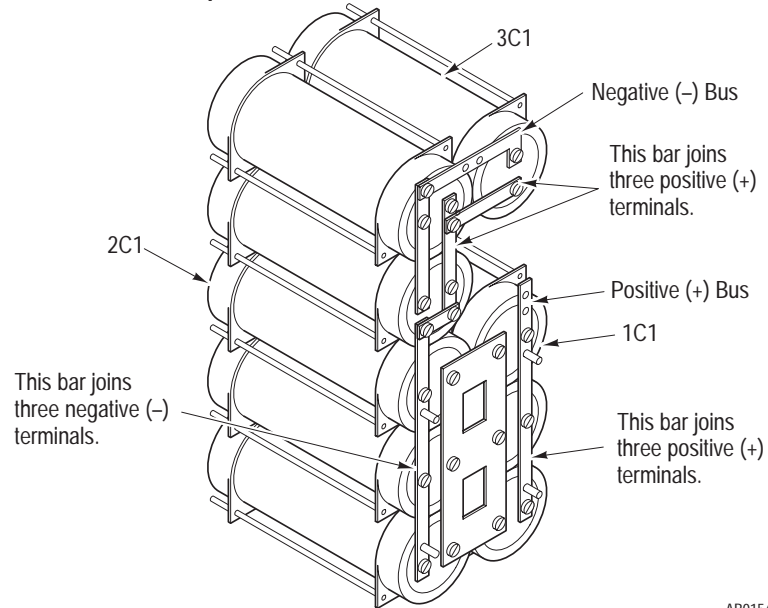

AB0154A



ATTENTION: Disconnect and lock out power from the drive before disassembling the drive. Failure to disconnect power may result in death or serious injury. A bus charge neon indicator provides visual indication that bus voltage is present. Verify bus voltage by measuring the voltage between +DC and –DC on Terminal Block TB1. Do not attempt to service the drive until the neon indicator has extinguished and the bus voltage has discharged to zero volts.

IMPORTANT: Before you remove connections, bus bars, and wires from the drive components, mark the connections, bus bars, and wires to correspond with their component connections and terminals to prevent incorrect wiring during assembly.

1. Remove power from the drive.
2. Wait for Bus Indicator Light DS1 to turn off. Check for zero volts at TB1 Terminals +DC and –DC.
3. Remove the protective plastic guard covering the capacitor terminals.
4. Restore power to the drive.



ATTENTION: Servicing energized industrial control equipment can be hazardous. Electrical shock, burns, or unintentional actuation of controlled industrial equipment may cause death or serious injury. Follow the safety-related practices of NFPA 70E, Electrical Safety for Employee Workplaces, when working on or near energized equipment. Do not work alone on energized equipment.

5. Connect the negative lead of your meter to the capacitor (–) bus bar and the positive lead to the capacitor (+) bus bar. Refer to the following table and former illustration for meter-to-capacitor lead connections, voltages, and capacitor terminal locations.

Table 1.E
Bus Capacitor Group Test

Drive Rating	Input Volts	Meter (+) Lead	Meter (–) Lead	Meter Reading
B	380	+ Bus	– Bus	535V DC +/-10%
	415	+ Bus	– Bus	580V DC +/-10%
	460	+ Bus	– Bus	650V DC +/-10%
C	500	+ Bus	– Bus	700V DC +/-10%
	575	+ Bus	– Bus	800V DC +/-10%
	600	+ Bus	– Bus	850V DC +/-10%

6. If the voltage is not within tolerance, check the voltage across each capacitor group. Measure the voltage across 1C1, then across 2C1. Refer to the following table and former illustration for meter-to-capacitor lead connections, voltages, and capacitor terminal locations.

Table 1.F
Bus Capacitor Test for Half the DC Bus Voltage

Drive Rating	Input Volts	Meter (+) Lead	Meter (–) Lead	Meter Reading
B	380	+ Bus	– Bus	267V DC +/-10%
	415	+ Bus	– Bus	290V DC +/-10%
	460	+ Bus	– Bus	325V DC +/-10%
C	500	+ Bus	– Bus	350V DC +/-10%
	575	+ Bus	– Bus	400V DC +/-10%
	600	+ Bus	– Bus	425V DC +/-10%

7. Check that the voltages across the capacitors are equal. If the voltages are unequal, replace the capacitor(s) and/or balancing resistor(s). The balancing resistors are located on the Main Chassis below the bus capacitors. Refer to Chapter 3 – Bus Capacitors.

8. If the voltages are low, check the following:

- A Precharge Circuit problem. Refer to Test 4 – Testing the Precharge Board, and Test 1 – Testing the Bridge Rectifiers.
- A malfunctioned Rectifier SCR1, SCR2, or SCR3.
- An open wire between Rectifiers SCR1, SCR2, SCR3, and the capacitor group.
- A voltage drop due to Inductor L1 resistance.

Test 3 Testing Transistor Modules X1 – X6

Transistor Modules X1 – X6 are located on the Main Chassis behind the Base Driver Mounting Plate and the Main Bus Bar assembly.

Figure 1.9
Transistor Module Test

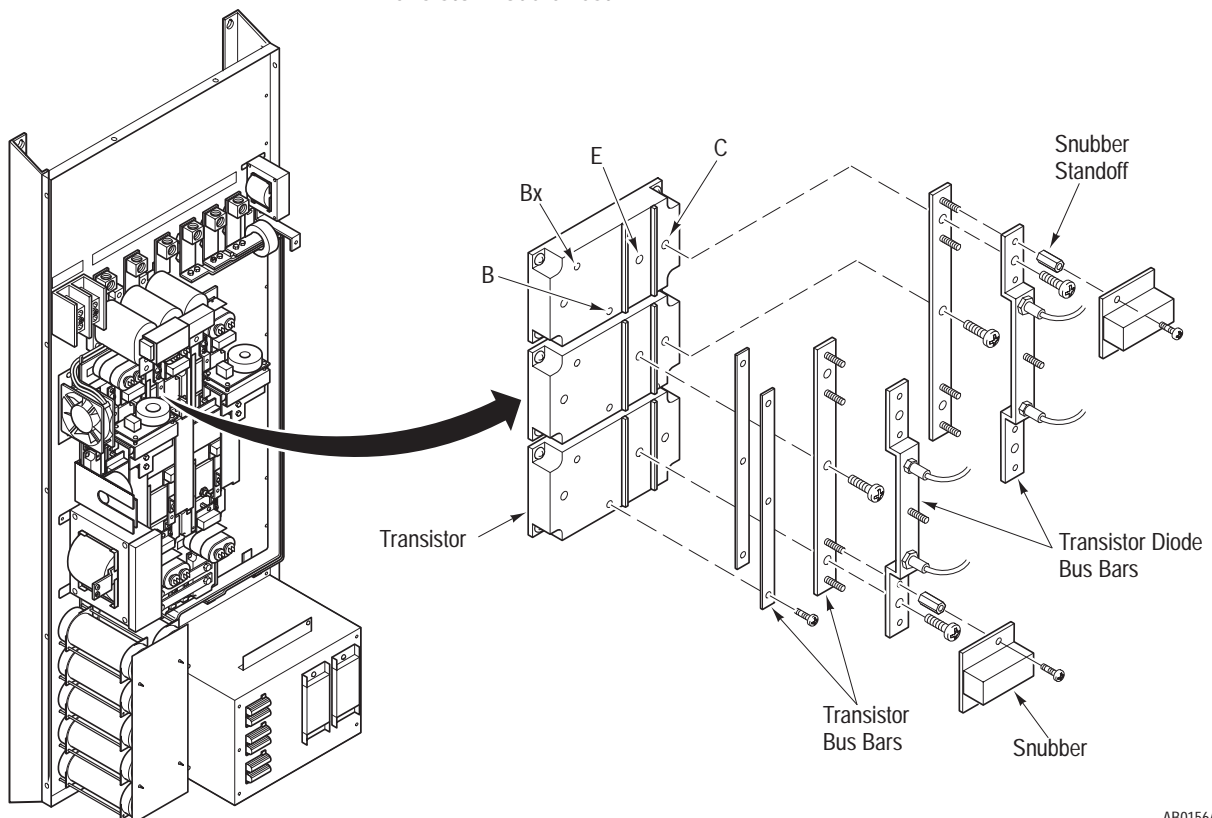

AB0156A



ATTENTION: Disconnect and lock out power from the drive before disassembling the drive. Failure to disconnect power may result in death or serious injury. A bus charge neon indicator provides visual indication that bus voltage is present. Verify bus voltage by measuring the voltage between +DC and –DC on Terminal Block TB1. Do not attempt to service the drive until the neon indicator has extinguished and the bus voltage has discharged to zero volts.

IMPORTANT: Before you remove connections, bus bars, and wires from the drive components, mark the connections, bus bars, and wires to correspond with their component connections and terminals to prevent incorrect wiring during assembly.

1. Remove power from the drive.
2. Wait for Bus Indicator Light DS1 to turn off before proceeding. Check for zero volts at TB1 Terminals +DC and –DC.
3. Remove the Main Bus Bar assembly. Refer to Chapter 2 – Removing the Main Bus Bar Assembly.
4. Remove the Steering Diode and Zener Diode wires from their connections.
5. Remove the screws fastening the Transistor Snubbers to the transistors.
6. Remove the nuts and Transistor Snubber standoffs fastening the Transistor Diode bus bars to the transistor bus bars.
7. Remove the screws fastening the Transistor Diode bus bars to the transistor bus bars.
8. Remove the bus bars connecting Transistor Terminals Bx, B, C, and E.
9. Set your meter to test diodes.
10. Test the transistors. The following table shows meter connections and ideal meter readings for those connections. Refer to the former illustration for meter connection locations.

Table 1.G
Transistor Module Test

Meter (+) Lead	Meter (-) Lead	Nominal Meter Reading
C	E	Infinite
E	C	0.27 Volts
B	E	0.08 Volts

11. If your readings do not match the table readings, replace the malfunctioned transistor, snubber, and diodes. Refer to Chapter 3 – Transistor Modules and Snubbers.

Test 4 Testing the Precharge Board

The Precharge Board is located behind the Main Control Mounting Plate. Resistors R7 and R8 are located on the Fan Housing.

Figure 1.10
Precharge Board Test

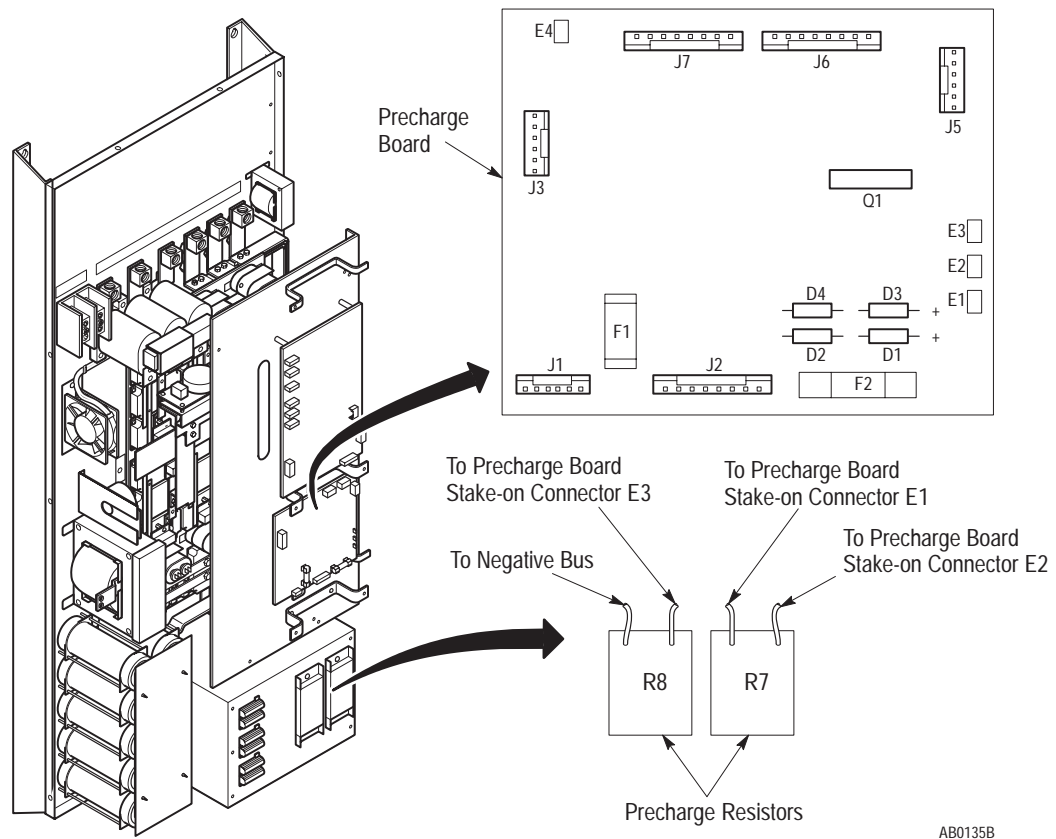

ATTENTION: Disconnect and lock out power from the drive before disassembling the drive. Failure to disconnect power may result in death or serious injury. A bus charge neon indicator provides visual indication that bus voltage is present. Verify bus voltage by measuring the voltage between +DC and -DC on Terminal Block TB1. Do not attempt to service the drive until the neon indicator has extinguished and the bus voltage has discharged to zero volts.

IMPORTANT: Before you remove connections, bus bars, and wires from the drive components, mark the connections, bus bars, and wires to correspond with their component connections and terminals to prevent incorrect wiring during assembly.

1. Remove power from the drive.
2. Wait for Bus Indicator Light DS1 to turn off before proceeding. Check for zero volts at TB1 Terminals +DC and –DC.
3. Remove the Main Control Mounting Plate. Refer to Chapter 2 – Removing the Main Control Mounting Plate.
4. Remove the following from the Precharge Board:
 - Connectors J1, J2, J3, J5, J6, and J7.
 - Stake-on Connectors E1 – E4.
5. Set your meter to measure resistance.
6. Test the Precharge Board and Resistors R7 and R8. The following table shows meter connections and ideal meter readings for tested components. All values are nominal resistance in ohms. Refer to the former illustration for meter connection locations.

Table 1.H
Precharge Board Test

Component	Reading
Fuse F1	0 Ohms
Fuse F2	0 Ohms
Resistor R7	28 Ohms
Resistor R8	28 Ohms

7. If your readings match the table readings, continue to Step 8 in this test. If your readings do not match the table readings for:
 - Resistors R7 and R8, replace the resistors. Continue with Step 8 in this test.
 - Fuses F1 or F2, replace the Precharge Board. Refer to Chapter 2 – Removing the Precharge Board.
8. Set your meter to test diodes.
9. Test the Precharge Board diodes. The following table shows ideal meter readings for tested components. Refer to the former illustration for meter connection locations.

Table 1.I
Precharge Board Diode Test

Component	Meter (+) Lead	Meter (-) Lead	Nominal Meter Reading
D1 – D4	Cathode	Anode	Open
D1 – D4	Anode	Cathode	0.5 Volts
Q1	Source	Drain	Open
Q1	Drain	Source	Open

10. If your readings do not match the table readings, replace the Precharge Board. Refer to Chapter 2 – Replacing the Precharge Board.

Test 5 Testing the Base Driver/ Power Supply Board

The Base Driver Board is located under the Main Control Mounting Plate. If one or more transistors has malfunctioned, you must test the Base Driver Board.

Figure 1.11
Base Driver Board Test

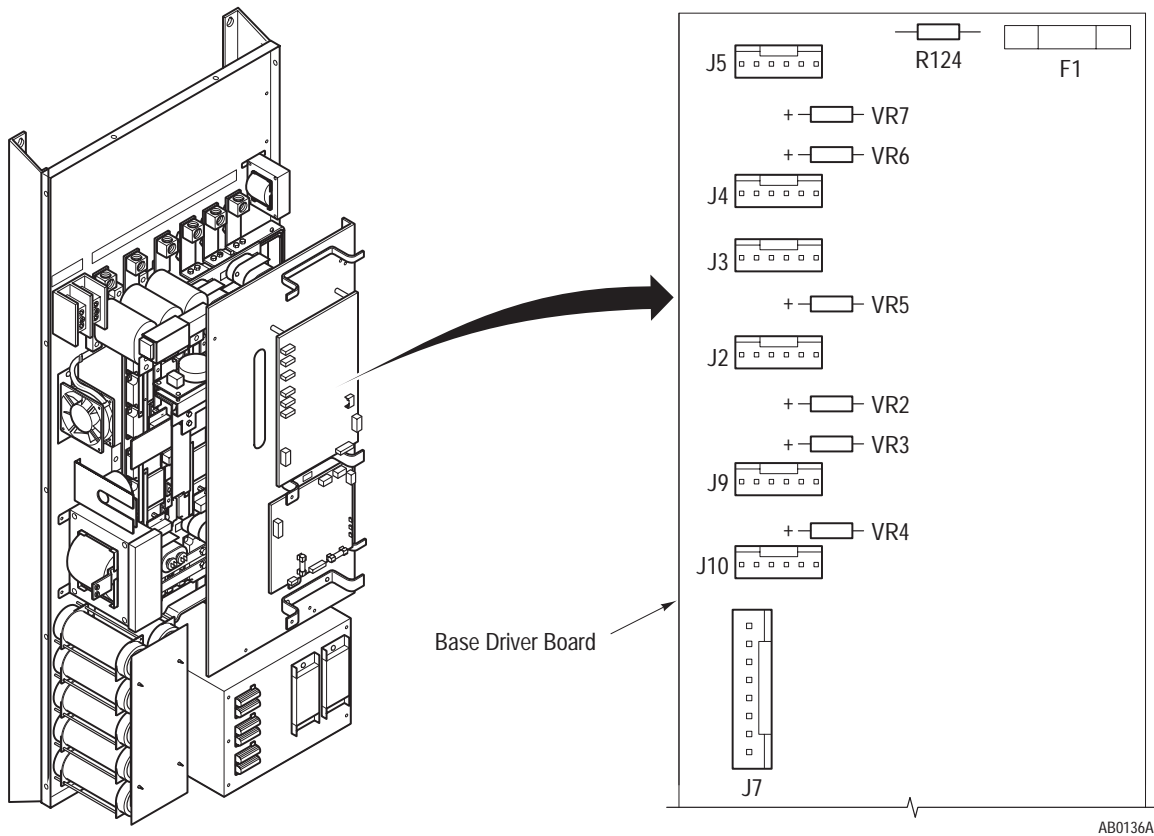

ATTENTION: Disconnect and lock out power from the drive before disassembling the drive. Failure to disconnect power may result in death or serious injury. A bus charge neon indicator provides visual indication that bus voltage is present. Verify bus voltage by measuring the voltage between +DC and –DC on Terminal Block TB1. Do not attempt to service the drive until the neon indicator has extinguished and the bus voltage has discharged to zero volts.

IMPORTANT: Before you remove connections, bus bars, and wires from the drive components, mark the connections, bus bars, and wires to correspond with their component connections and terminals to prevent incorrect wiring during assembly.

1. Remove power from the drive.
2. Wait for Bus Indicator Light DS1 to turn off. Check for zero volts at TB1 Terminals +DC and –DC.
3. Remove the Main Control Mounting Plate. Refer to Chapter 2 – Removing the Main Control Mounting Plate.
4. Remove Connectors J2 – J5, J9, and J10 from the Base Driver Board.
5. Set your meter to test diodes.
6. Test VR2 through VR7. The following table shows meter connections at the components and ideal meter readings for those connections. Refer to the former illustration for meter connection locations.

Table 1.J
Base Driver Board Test

Component	Meter (+) Lead	Meter (-) Lead	Nominal Meter Reading
VR2	+	-	2.9 Volts
	-	+	Infinite
VR3	+	-	2.9 Volts
	-	+	Infinite
VR4	+	-	1.2 Volts
	-	+	1.0 Volts
VR5	+	-	1.0 Volts
	-	+	0.5 Volts
VR6	+	-	1.0 Volts
	-	+	0.5 Volts
VR7	+	-	1.0 Volts
	-	+	0.5 Volts

7. If your readings do not match the table readings, replace the Base Driver Board. Refer to Chapter 2 – Removing the Base Driver/Power Supply Board.

This Page Intentionally Left Blank

Disassembly and Access Procedures

Chapter Objectives

This chapter describes general disassembly procedures required to access internal drive components.

Disassembly and Access Overview



ATTENTION: Some printed circuit boards and drive components may contain hazardous voltage levels. If neon light DS1 on the Base Driver Board is illuminated, hazardous voltages are present in the drive circuit boards. Remove and lock out power before you disconnect or reconnect wires, and before you remove or replace fuses and circuit boards. Verify bus voltage by measuring the voltage between +DC and –DC on Terminal Block TB1. Do not attempt to service the drive until the neon indicator has extinguished and the bus voltage has discharged to zero volts.

Electrostatic Discharge Precautions



ATTENTION: This assembly contains parts and sub-assemblies that are sensitive to electrostatic discharge. Static control precautions are required when servicing this assembly. Component damage may result if you ignore electrostatic discharge control procedures. If you are not familiar with static control procedures, reference Allen-Bradley Publication 8000-4.5.2, Guarding Against Electrostatic Discharge, or any other applicable ESD protection handbook.

Electrostatic discharge generated by static electricity can damage the complimentary metallic oxide semiconductor devices on various drive boards. It is recommended that you perform these procedures to guard against this type of damage when circuit boards are removed or installed:

- Wear a wrist type grounding strap that is grounded to the chassis.
- Attach the wrist strap before removing the new circuit board from the conductive packet.
- Remove boards from the drive and immediately insert them into their conductive packets.

Tools

You need the following tools to disassemble and assemble the drive:

- Pliers
- #1 Phillips screwdriver
- #2 Phillips screwdriver
- #3 Phillips screwdriver
- #4-5 standard screwdriver
- #8-10 standard screwdriver
- 3/8-inch or 9.6mm open-end wrench
- 3/8-inch or 9.6mm socket
- 11/16-inch or 17.5mm open-end wrench
- 9/16-inch or 15mm socket
- 7/16-inch or 11.5mm open-end wrench
- 7/16-inch or 11.5mm socket
- 5/16-inch or 8mm Allen wrench
- Torque wrench, metered in lb-in. or N-m

Fastener Torque Specifications

Torque Sequence

When mounting components to a drive's heat sink, component-fastener torque sequences and tolerances are crucial to component-to-heat sink heat dissipation.

Two-Point Mounting

The following illustrates temporary and final tightening sequences for components fastened to a heat sink using two screws. The alpha-numeric illustration labels are for your assistance. Drive components do not carry these labels.

Figure 2.1
Two-Point Mounting

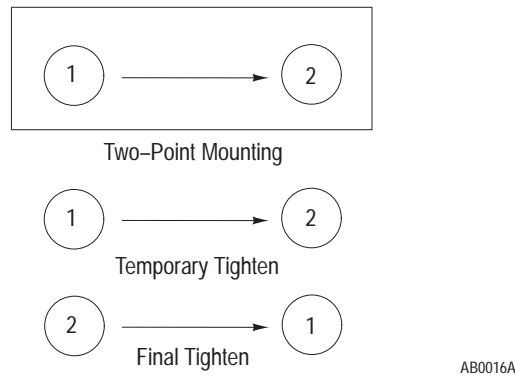

Four-Point Mounting

The following illustrates temporary and final tightening sequences for components fastened to a heat sink using four screws. The alpha-numeric illustration labels are for your assistance. Drive components do not carry these labels.

Figure 2.2
Four-Point Mounting

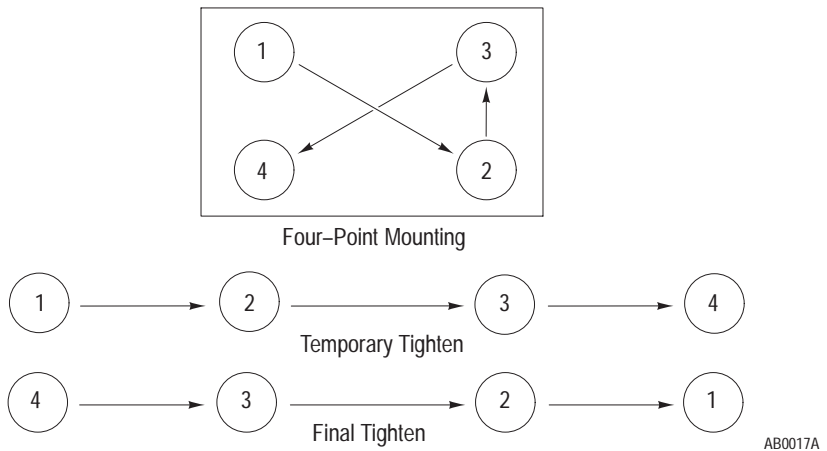

Torque Specifications

The following table lists fastener locations by component, how the fasteners are used, and torque specifications. Refer to Torque Sequence in this chapter for fastening two-point and four-point components to the heat sink.

Table 2.A
Fastener Torque Specifications

Component	Fastener Application	Torque, lb-in.	Torque, N-m
Bus Capacitor	Wires to terminals	45 – 55	5.1 – 6.2
Balancing Resistors	Resistors to fan housing	2.6 – 3.0	0.29 – 0.30
SCR Modules	Wires to terminals	70 – 90	7.9 – 10.1
SCR Modules	SCR to heat sink	35 – 40	3.4 – 4.5
Transistor Modules X1 – X6	C and E terminal wires	22 – 31	2.5 – 3.6
Transistor Modules X1 – X6	Module to heat sink	22 – 31	2.5 – 3.6
Transistor Modules X1 – X6	B and Bx terminal wires	9 – 15	1.0 – 1.7
Snubbers	Snubbers to transistors	9 – 15	1.0 – 1.7
Terminal Strip TB1, M1 – M3, L1 – L3	Wires to terminals	375	42
Terminal Strip TB1, +DC, -DC	Wires to terminals	275	31
Terminal Strip TB2	Wires to terminals	7	0.8
Terminal Strip TB3	Wires to terminals	7	0.8
Bus Resistors	Resistors to Bus Bar	2.6 – 3.0	0.29 – 0.30

Disassembly and Access Procedures

Removing the Drive Enclosure

The Drive Enclosure is optional equipment for drives that are not enclosed within a larger electrical control cabinet.

Figure 2.3
Drive Enclosure

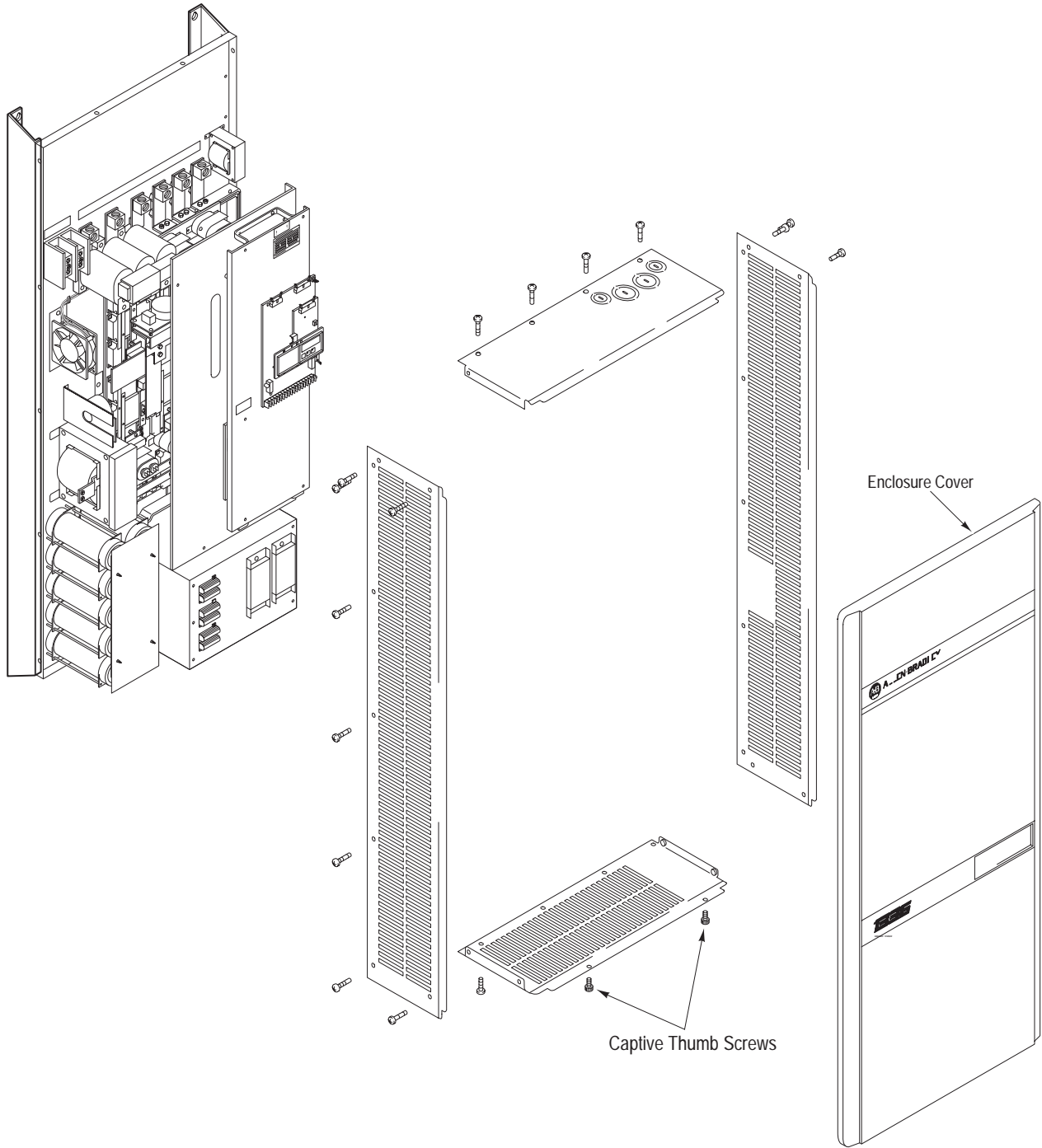

AB0051A

Removal



ATTENTION: Disconnect and lock out power from the drive before disassembling the drive. Failure to disconnect power may result in death or serious injury. A bus charge neon indicator provides visual indication that bus voltage is present. Verify bus voltage by measuring the voltage between +DC and –DC on Terminal Block TB1. Do not attempt to service the drive until the neon indicator has extinguished and the bus voltage has discharged to zero volts.



ATTENTION: Wear a wrist-type grounding strap when servicing 1336 Drives. Failure to protect drive components against ESD may damage drive components. Refer to Electrostatic Discharge Precautions at the beginning of this chapter.

1. Remove power from the drive.
2. Remove the captive thumb screw fastening the Enclosure cover to the bottom of the Enclosure frame.
3. Pull the bottom of the cover outward to clear the Enclosure frame, then lift the cover upward to remove the cover.
4. Remove the screws from the Enclosure frame side panels.
5. Remove the screws from the Enclosure frame top and bottom panels.
6. Wait for Bus Indicator Light DS1 to turn off before proceeding with internal component disassembly. Check for zero volts at TB1 Terminals +DC and –DC.

Installation

Install the Enclosure in reverse order of removal.



ATTENTION: Replace all guards before applying power to the drive. Failure to replace guards may result in death or serious injury.

Removing Logic Interface Board MOD-L1, -L2, or L3

The Logic Interface Board is optional equipment. This board is located on the Main Control Board, below the Programming and Display Board.

Figure 2.4
Logic Interface Board

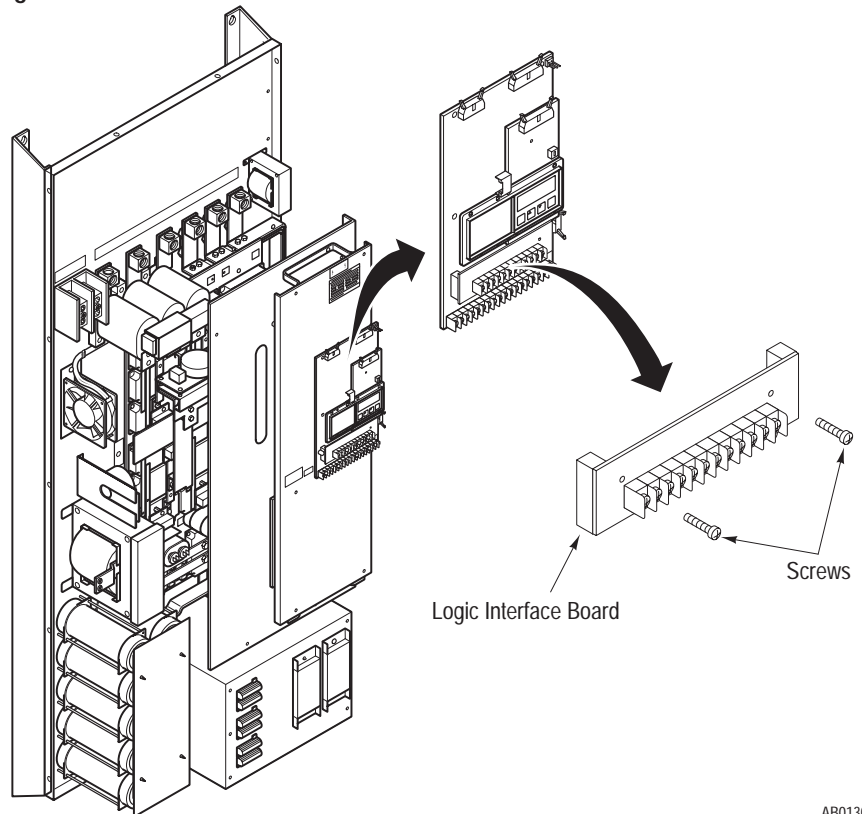

AB0130A

Removal



ATTENTION: Disconnect and lock out power from the drive before disassembling the drive. Failure to disconnect power may result in death or serious injury. A bus charge neon indicator provides visual indication that bus voltage is present. Verify bus voltage by measuring the voltage between +DC and -DC on Terminal Block TB1. Do not attempt to service the drive until the neon indicator has extinguished and the bus voltage has discharged to zero volts.



ATTENTION: Wear a wrist-type grounding strap when servicing 1336 Drives. Failure to protect drive components against ESD may damage drive components. Refer to Electrostatic Discharge Precautions at the beginning of this chapter.

IMPORTANT: Before you remove connections, bus bars, and wires from the drive components, mark the connections, bus bars, and wires to correspond with their component connections and terminals to prevent incorrect wiring during assembly.

1. Remove power from the drive. Check for zero volts at TB1 Terminals +DC and -DC.
2. Remove the Enclosure cover if the drive has an enclosure. Refer to Removing the Drive Enclosure in this chapter.
3. Remove all wires from the terminals on TB3.
4. Loosen the two captive screws fastening the Logic Interface Board to the Main Control Board Connectors J8 and J9.
5. Grip the right and left sides of the Logic Interface Board and pull the board straight outward from the Main Control Board.

Installation

Install the Logic Interface Board in reverse order of removal.



ATTENTION: Replace all guards before applying power to the drive. Failure to replace guards may result in death or serious injury.

Removing the Programming and Display Board

The Programming and Display Board is located on the Main Control Board.

Figure 2.5
Programming and Display Board

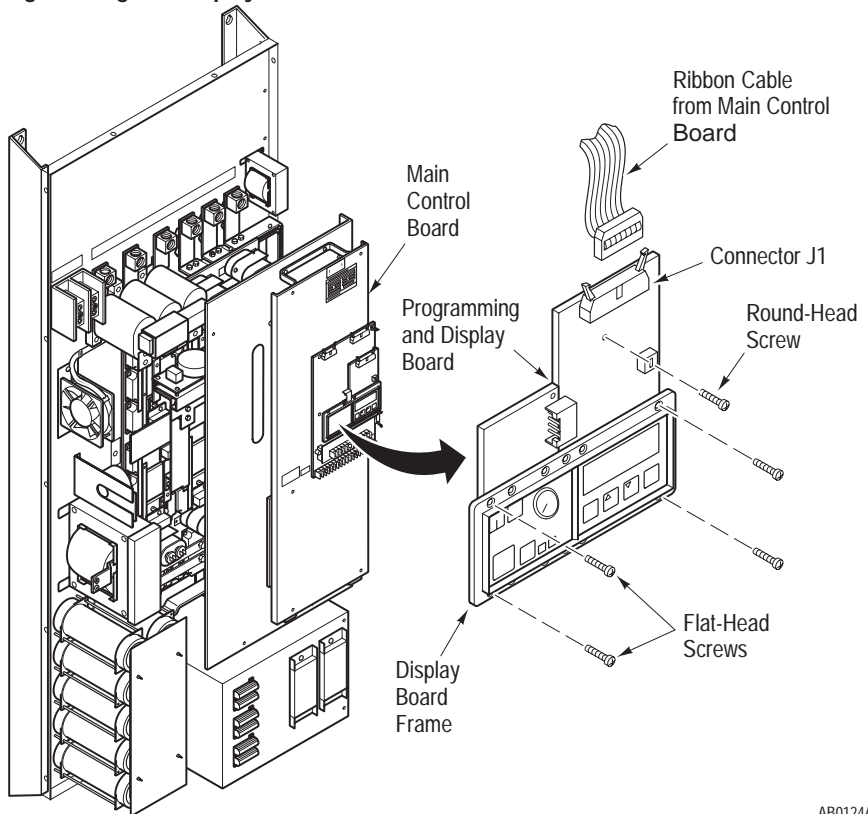

AB0124A

Removal



ATTENTION: Disconnect and lock out power from the drive before disassembling the drive. Failure to disconnect power may result in death or serious injury. A bus charge neon indicator provides visual indication that bus voltage is present. Verify bus voltage by measuring the voltage between +DC and -DC on Terminal Block TB1. Do not attempt to service the drive until the neon indicator has extinguished and the bus voltage has discharged to zero volts.



ATTENTION: Wear a wrist-type grounding strap when servicing 1336 Drives. Failure to protect drive components against ESD may damage drive components. Refer to Electrostatic Discharge Precautions at the beginning of this chapter.

IMPORTANT: Before you remove connections, bus bars, and wires from the drive components, mark the connections, bus bars, and wires to correspond with their component connections and terminals to prevent incorrect wiring during assembly.

1. Remove power from the drive. Check for zero volts at TB1 Terminals +DC and –DC.
2. Remove the Enclosure cover if the drive has an enclosure. Refer to Removing the Drive Enclosure in this chapter.
3. Remove the ribbon cable from Display Board Connector J1.
4. Remove the flat-head screws from the four corners of the grey Display Board frame.
5. Remove the round-head screw from the Display Board's printed circuit board.
6. Remove the Programming and Display Board from the Main Control Board.

Installation

Install the Programming and Display Board in reverse order of removal.



ATTENTION: Replace all guards before applying power to the drive. Failure to replace guards may result in death or serious injury

Removing the Main Control Board from the Mounting Plate

The Main Control Board is located on the Main Control Mounting Plate and behind the Programming and Display Board.

Figure 2.6
Main Control Board and Mounting Plate

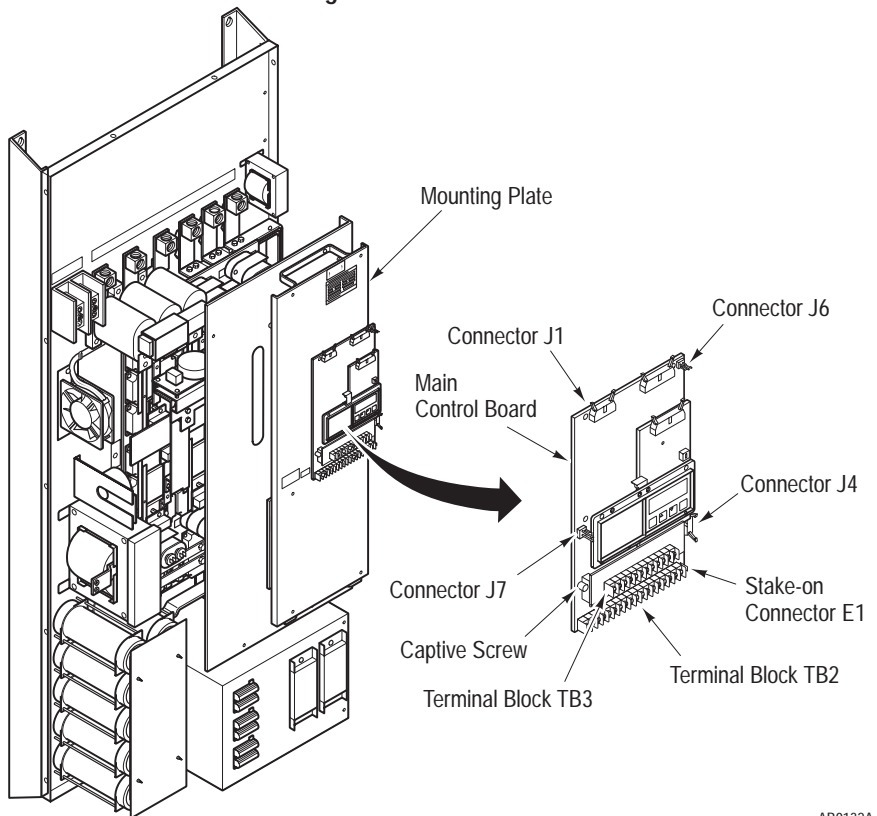

AB0132A

Removal



ATTENTION: Disconnect and lock out power from the drive before disassembling the drive. Failure to disconnect power may result in death or serious injury. A bus charge neon indicator provides visual indication that bus voltage is present. Verify bus voltage by measuring the voltage between +DC and –DC on Terminal Block TB1. Do not attempt to service the drive until the neon indicator has extinguished and the bus voltage has discharged to zero volts.



ATTENTION: Wear a wrist-type grounding strap when servicing 1336 Drives. Failure to protect drive components against ESD may damage drive components. Refer to Electrostatic Discharge Precautions at the beginning of this chapter.

IMPORTANT: Before you remove connections, bus bars, and wires from the drive components, mark the connections, bus bars, and wires to correspond with their component connections and terminals to prevent incorrect wiring during assembly.

1. Remove power from the drive. Check for zero volts at TB1 Terminals +DC and –DC.
2. Remove the Enclosure cover if the drive has an enclosure. Refer to Removing the Drive Enclosure in this chapter.
3. Remove the Logic Interface Board and the Programming and Display Board. Refer to Removing the Logic Interface Board and Removing the Programming and Display Board procedures in this chapter.
4. Disconnect the following from the Main Control Board:
 - J1 ribbon cable
 - J6 connector
 - J7 connector
 - E1 stake-on connector
 - J4 ribbon cable connector, if MOD-S1 is used
 - All wires from the TB2 terminals
5. Remove the two captive screws fastening the Main Control Board to the Mounting Plate. These screws are located near Main Control Board Connectors J8 and J9.
6. Turn the six standoff screws 1/4 turn counterclockwise.
7. Pull the Main Control Board away from the standoffs.

Installation

Install the Main Control Board in reverse order of removal.



ATTENTION: Replace all guards before applying power to the drive. Failure to replace guards may result in death or serious injury.

Removing the Main Control Mounting Plate

The Main Control Mounting Plate holds the Main Control Board, the Programming and Display Board, and the optional Logic Interface Board.

Figure 2.7
Main Control Mounting Plate

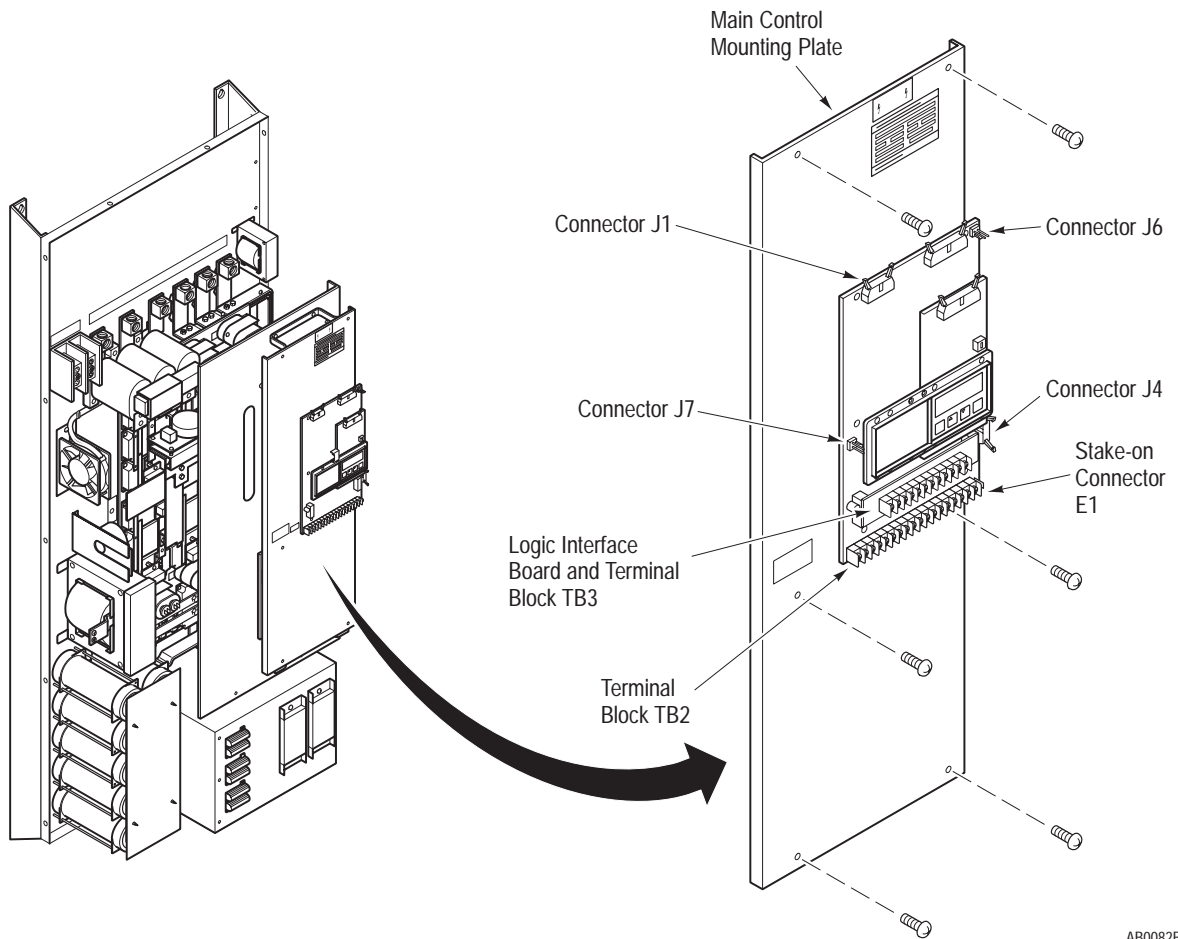

AB0082B

Removal



ATTENTION: Disconnect and lock out power from the drive before disassembling the drive. Failure to disconnect power may result in death or serious injury. A bus charge neon indicator provides visual indication that bus voltage is present. Verify bus voltage by measuring the voltage between +DC and –DC on Terminal Block TB1. Do not attempt to service the drive until the neon indicator has extinguished and the bus voltage has discharged to zero volts.



ATTENTION: Wear a wrist-type grounding strap when servicing 1336 Drives. Failure to protect drive components against ESD may damage drive components. Refer to Electrostatic Discharge Precautions at the beginning of this chapter.

IMPORTANT: Before you remove connections, bus bars, and wires from the drive components, mark the connections, bus bars, and wires to correspond with their component connections and terminals to prevent incorrect wiring during assembly.

1. Remove power from the drive.
2. Remove the Enclosure cover from the drive. Refer to Removing the Drive Enclosure in this chapter.
3. Wait for Bus Indicator Light DS1 to turn off. Check for zero volts at TB1 Terminals +DC and –DC before proceeding.
4. Remove the following from the Main Control Board:
 - J6 connector
 - J7 connector
 - E1 stake-on connector
 - J4 ribbon cable connector if MOD-S1 is used
 - All wires from TB2 terminals
5. Remove the ribbon cable from Base Driver/Power Supply Board Connector J1. Reach through the hole below the Main Control Board on the Main Control Mounting Plate to access the connection.
6. Remove all wires from the TB3 terminals if a Logic Interface Board is being used.
7. Remove the six screws fastening the Main Control Mounting Plate to the Base Driver Mounting Plate.

Removing the Precharge Board

The Precharge Board is located below the Base Driver/Power Supply Board on the Base Driver Mounting Plate.

Figure 2.8
Precharge Board

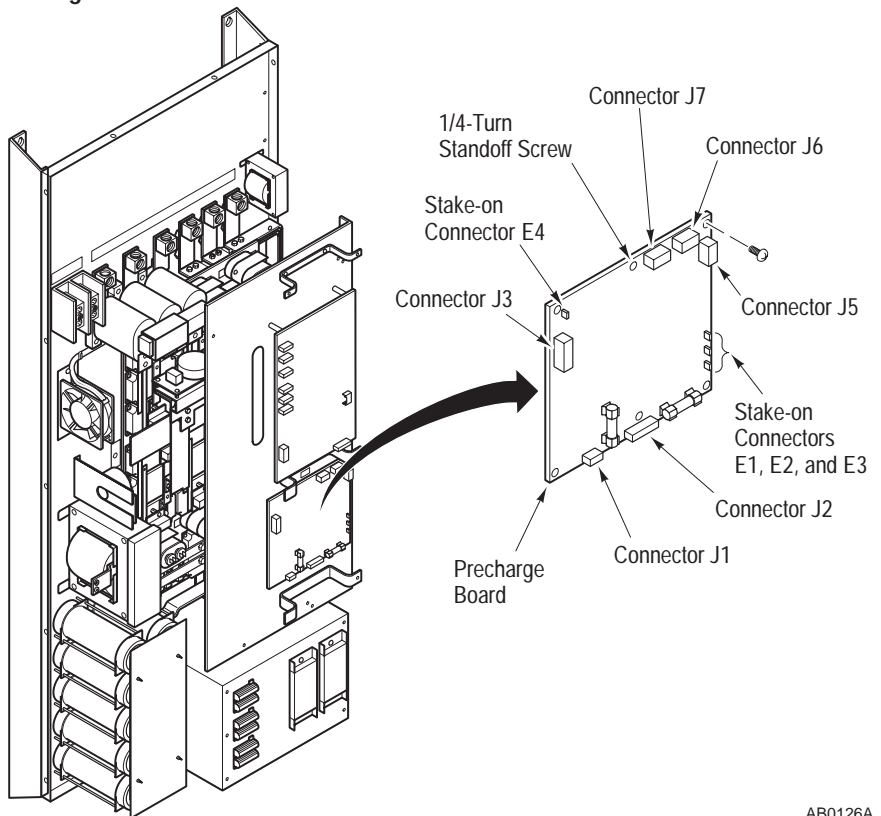

AB0126A

Removal



ATTENTION: Disconnect and lock out power from the drive before disassembling the drive. Failure to disconnect power may result in death or serious injury. A bus charge neon indicator provides visual indication that bus voltage is present. Verify bus voltage by measuring the voltage between +DC and -DC on Terminal Block TB1. Do not attempt to service the drive until the neon indicator has extinguished and the bus voltage has discharged to zero volts.



ATTENTION: Wear a wrist-type grounding strap when servicing 1336 Drives. Failure to protect drive components against ESD may damage drive components. Refer to Electrostatic Discharge Precautions at the beginning of this chapter.

IMPORTANT: Before you remove connections, bus bars, and wires from the drive components, mark the connections, bus bars, and wires to correspond with their component connections and terminals to prevent incorrect wiring during assembly. Where connectors pass through access holes in mounting plates, mark the holes to correspond with the connectors that pass through the holes.

1. Remove the Main Control Mounting Plate from the drive. Refer to Removing the Main Control Mounting Plate in this chapter.
2. Disconnect the following from the Precharge Board:
 - J1 through J3 connectors
 - J5 through J7 connectors
 - E1 through E4 wires at the stake-on connectors.
3. Remove the four screws fastening the Precharge Board to the Base Driver Mounting Plate.
4. Turn the two standoff screws on the Precharge Board 1/4 turn counterclockwise.
5. Pull the Precharge Board away from the standoffs.

Installation

Install the Precharge Board in reverse order of removal.



ATTENTION: Replace all guards before applying power to the drive. Failure to replace guards may result in death or serious injury.

Removing the Base Driver/Power Supply Board

The Base Driver/Power Supply Board is located on the Base Driver Mounting Plate and behind the Main Control Mounting Plate.

Figure 2.9
Base Driver/Power Supply Board

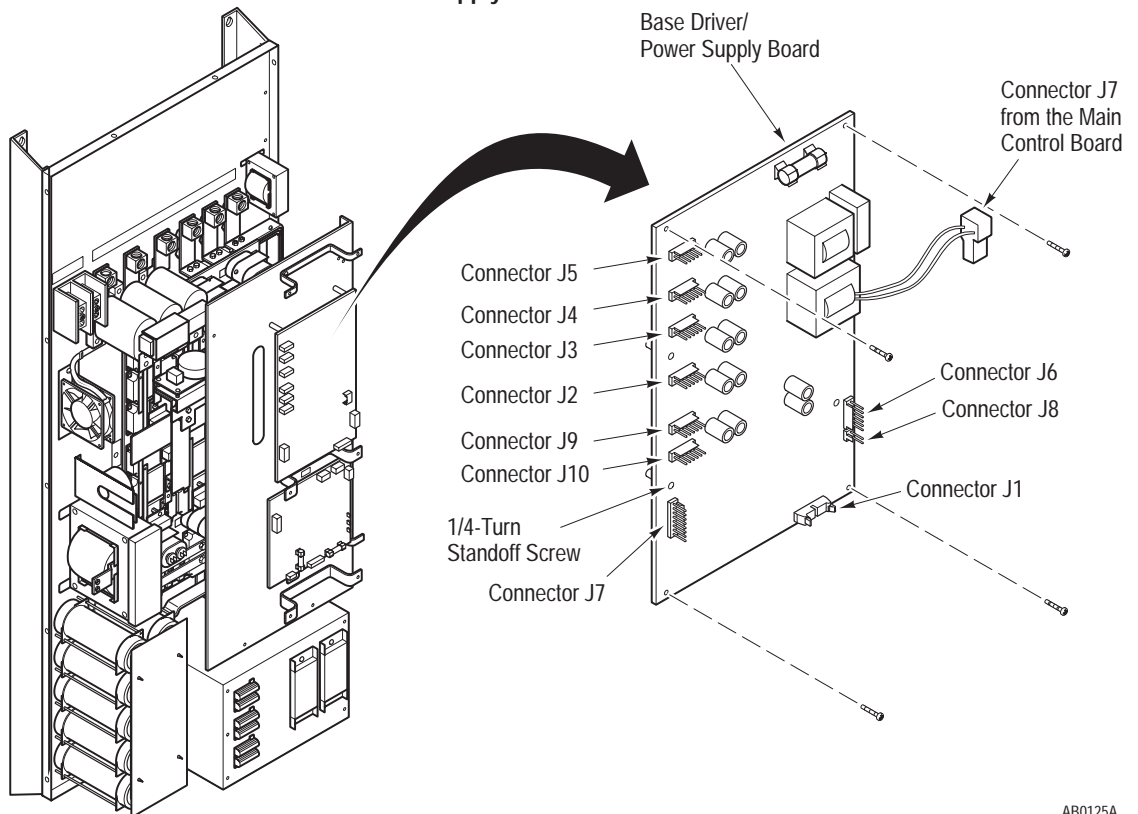

AB0125A

Removal



ATTENTION: Disconnect and lock out power from the drive before disassembling the drive. Failure to disconnect power may result in death or serious injury. A bus charge neon indicator provides visual indication that bus voltage is present. Verify bus voltage by measuring the voltage between +DC and -DC on Terminal Block TB1. Do not attempt to service the drive until the neon indicator has extinguished and the bus voltage has discharged to zero volts.



ATTENTION: Wear a wrist-type grounding strap when servicing 1336 Drives. Failure to protect drive components against ESD may damage drive components. Refer to Electrostatic Discharge Precautions at the beginning of this chapter.

IMPORTANT: Before you remove connections, bus bars, and wires from the drive components, mark the connections, bus bars, and wires to correspond with their component connections and terminals to prevent incorrect wiring during assembly. Where connectors pass through access holes in mounting plates, mark the holes to correspond with the connectors that pass through the holes.

1. Remove power from the drive. Wait for Bus Indicator Light DS1 to turn off before proceeding.
2. Remove the Main Control Mounting Plate from the drive. Refer to Removing the Main Control Mounting Plate in this chapter.
3. Remove Connectors J2 through J10 from the Base Driver Board.
4. Remove the four screws fastening the Base Driver Board to the Base Driver Mounting Plate. These screws are located at the corners of the Base Driver Board.
5. Turn the four standoff screws 1/4 turn counterclockwise.
6. Pull the Base Driver Board away from the standoffs.

Installation

Install the Base Driver/Power Supply Board in reverse order of removal.



ATTENTION: Replace all guards before applying power to the drive. Failure to replace guards may result in death or serious injury.

Removing the Base Driver Mounting Plate

The Base Driver Mounting Plate holds the Precharge Board and the Base Driver/Power Supply Board, and supports the Main Control Mounting Plate. This mounting plate is located behind the Main Control Mounting Plate.

Figure 2.10
Base Driver Mounting Plate

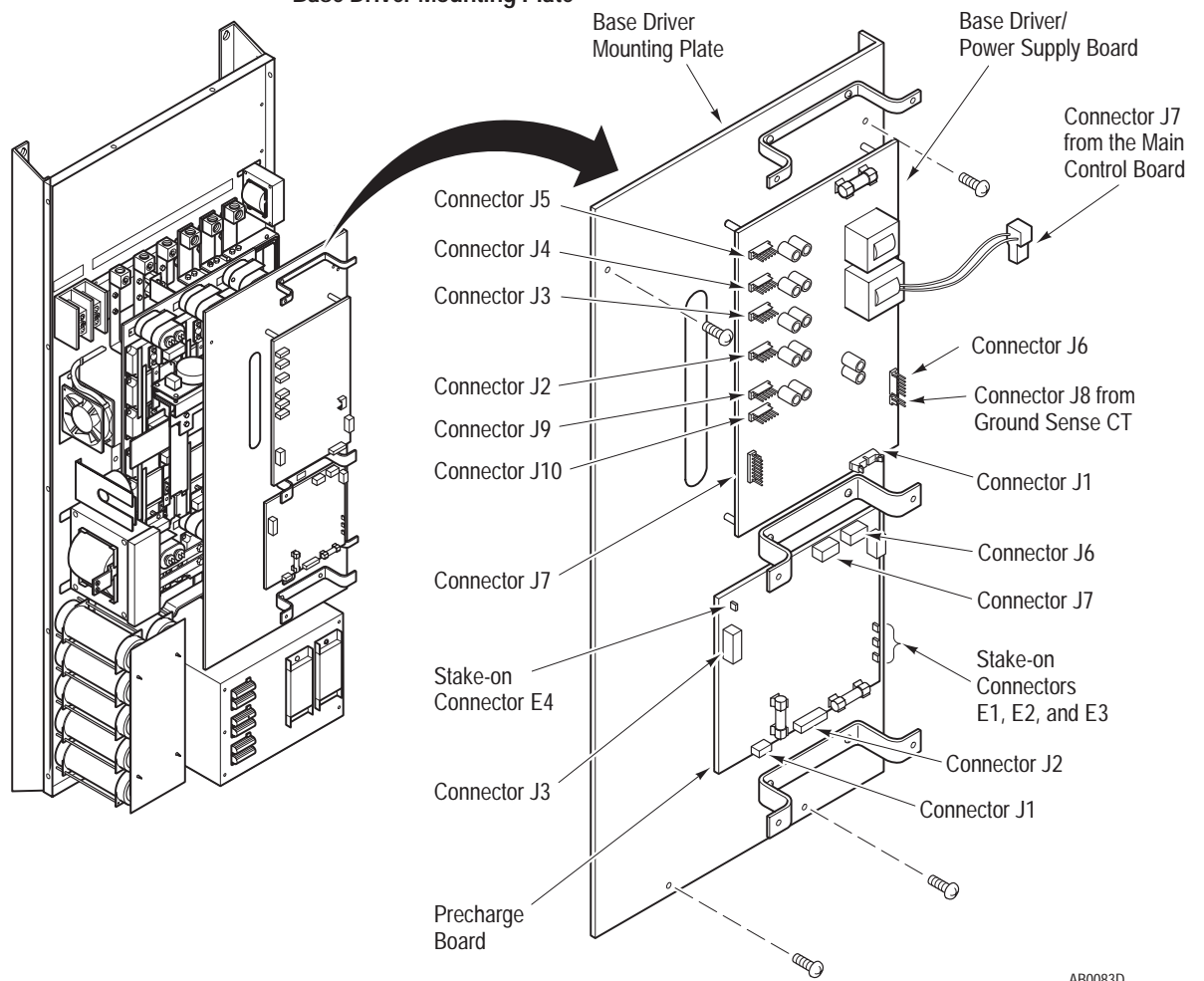

AB0083D

Removal



ATTENTION: Disconnect and lock out power from the drive before disassembling the drive. Failure to disconnect power may result in death or serious injury. A bus charge neon indicator provides visual indication that bus voltage is present. Verify bus voltage by measuring the voltage between +DC and –DC on Terminal Block TB1. Do not attempt to service the drive until the neon indicator has extinguished and the bus voltage has discharged to zero volts.



ATTENTION: Wear a wrist-type grounding strap when servicing 1336 Drives. Failure to protect drive components against ESD may damage drive components. Refer to Electrostatic Discharge Precautions at the beginning of this chapter.

IMPORTANT: Before you remove connections, bus bars, and wires from the drive components, mark the connections, bus bars, and wires to correspond with their component connections and terminals to prevent incorrect wiring during assembly. Where connectors pass through access holes in mounting plates, mark the holes to correspond with the connectors that pass through the holes.

1. Remove the Main Control Mounting Plate from the drive. Refer to Removing the Main Control Mounting Plate in this chapter.
2. Remove Connectors J2 – J5 and J7 – J10 from the Base Driver Board.
3. Remove the following from the Precharge Board:
 - J1 – J3 connectors
 - J6 and J7 connectors
 - E1 – E4 wires at the stake-on connectors
4. Remove the four screws fastening the Base Driver Mounting Plate to the drive.

Installation

Install the Base Driver Mounting Plate in reverse order of removal.



ATTENTION: Replace all guards before applying power to the drive. Failure to replace guards may result in death or serious injury.

Removing the Main Bus Bar Assembly

The Main Bus Bar assembly is located behind the Base Driver Mounting Plate and is connected to the transistors.

Figure 2.11
Main Bus Bar Assembly

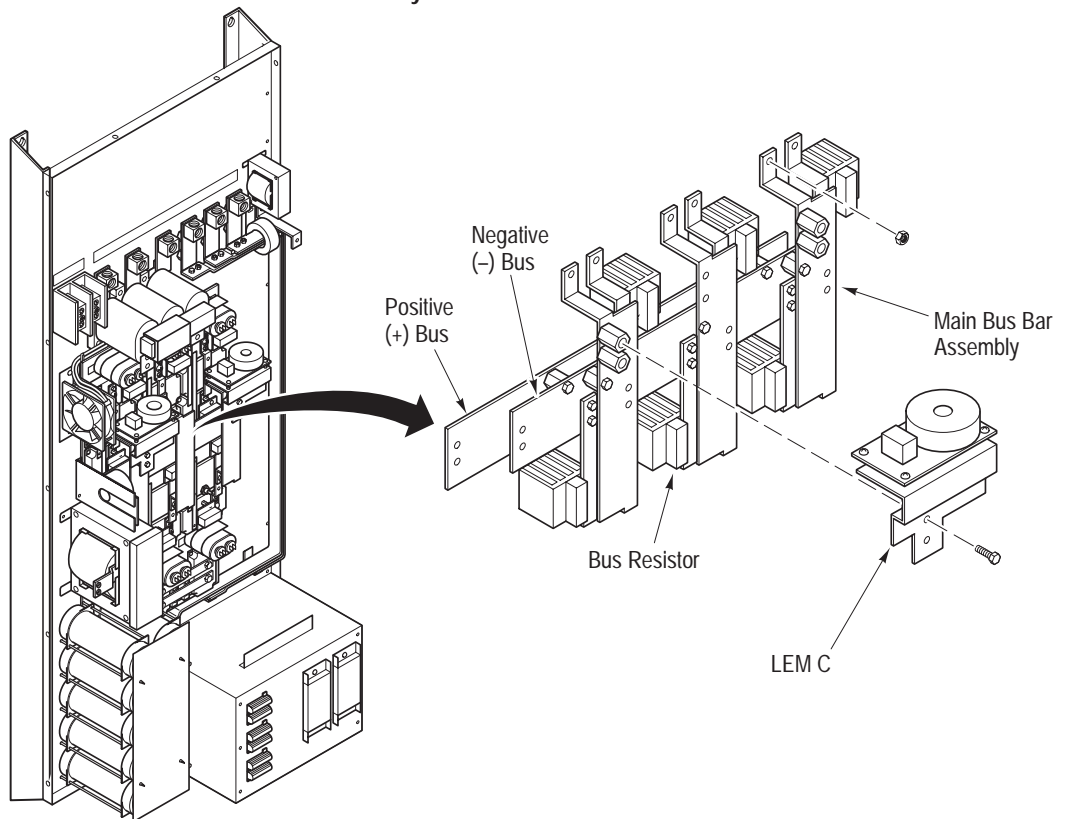

AB0131A

Removal



ATTENTION: Disconnect and lock out power from the drive before disassembling the drive. Failure to disconnect power may result in death or serious injury. A bus charge neon indicator provides visual indication that bus voltage is present. Verify bus voltage by measuring the voltage between +DC and -DC on Terminal Block TB1. Do not attempt to service the drive until the neon indicator has extinguished and the bus voltage has discharged to zero volts.



CAUTION: Wear a wrist-type grounding strap when servicing 1336 Drives. Failure to protect drive components against ESD may damage drive components. Refer to Electrostatic Discharge Precautions at the beginning of this chapter.

IMPORTANT: Before you remove connections, bus bars, and wires from the drive components, mark the connections, bus bars, and wires to correspond with their component connections and terminals to prevent incorrect wiring during assembly.

1. Remove the Base Driver Mounting Plate from the drive. Refer to Removing the Base Driver Mounting Plate in this chapter.
2. Remove the screws fastening the M1, M2, and M3 wires to the Main Bus Bar assembly.
3. Remove the +DC and –DC wires from the Main Bus Bar assembly.
4. Remove the screws fastening LEM A and LEM C to the Main Bus Bar assembly.
5. Remove the Bus Resistor wires from the Transistor Snubber stake-on connectors.
6. Remove the nuts fastening the Main Bus Bar assembly to the Transistor Diode bus bars, located on the transistors.

Installation

Install the Main Bus Bar assembly in reverse order of removal.



WARNING: Replace all guards before applying power to the drive. Failure to replace guards may result in death or serious injury.

Accessing Chassis Power Components

To access the power components located on the chassis, refer to Removing the Base Driver Mounting Plate, Removing the Main Control Mounting Plate, and Removing the Main Bus Bar Assembly in this chapter.

Part Replacement Procedures

Chapter Objective

This chapter describes procedures required to replace drive components. This chapter references Chapter 2 – Disassembly and Access Procedures for basic drive component access.

Part Replacement Overview

The part replacement procedures in this chapter assume that the drive you are servicing either has no enclosure or that the enclosure is removed from the drive. For more information on removing the Drive Enclosure, refer to Chapter 2 – Disassembly and Access Procedures, Removing the Drive Enclosure.

Safety Precautions



ATTENTION: Some printed circuit boards and drive components may contain hazardous voltage levels. If Bus Indicator neon light DS1 on the Base Driver Board is illuminated, hazardous voltages are present in the drive circuit boards. Remove power before you disconnect or reconnect wires, and before you remove or replace fuses and circuit boards. Verify bus voltage by measuring the voltage between +DC and –DC on Terminal Block TB1. Do not attempt to service the drive until the neon indicator has extinguished and the bus voltage has discharged to zero volts.

Electrostatic Discharge Precautions



ATTENTION: This assembly contains parts and sub-assemblies that are sensitive to electrostatic discharge. Static control precautions are required when servicing this assembly. Component damage may result if you ignore electrostatic discharge control procedures. If you are not familiar with static control procedures, reference Allen-Bradley Publication 8000-4.5.2, Guarding Against Electrostatic Discharge, or any other applicable ESD protection handbook.

Electrostatic discharge generated by static electricity can damage the complimentary metallic oxide semiconductor devices on various drive boards. It is recommended that you perform these procedures to guard against this type of damage when circuit boards are removed or installed:

- Wear a wrist type grounding strap that is grounded to the chassis.
- Attach the wrist strap before removing the new circuit board from the conductive packet.
- Remove boards from the drive and immediately insert them into their conductive packets.

Tools

You need the following tools to disassemble and assemble the drive:

- Pliers
- #1 Phillips screwdriver
- #2 Phillips screwdriver
- #3 Phillips screwdriver
- #4-5 standard screwdriver
- #8-10 standard screwdriver
- 3/8-inch or 9.6mm open-end wrench
- 3/8-inch or 9.6mm socket
- 11/16-inch or 17.5mm open-end wrench
- 7/16-inch or 11.5mm open-end wrench
- 7/16-inch or 11.5mm socket
- 9/16-inch or 14.5mm socket
- 5/16-inch or 8mm Allen wrench
- Torque wrench, metered in lb-in. or N-m
- Wire-terminal crimping tool

Fastener Torque Specifications

Torque Sequence

When mounting components to a drive's heat sink, component fastener torque sequences and tolerances are crucial to component-to-heat sink heat dissipation.

Two-Point Mounting

The following illustrates temporary and final tightening sequences for components fastened to a heat sink using two screws. The illustration labels are for your assistance. Drive components do not carry these labels.

Figure 3.1
Two-Point Mounting

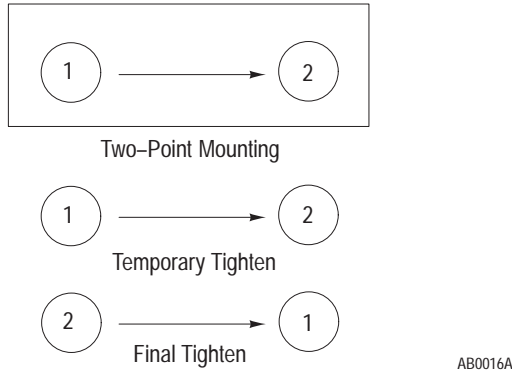

Four-Point Mounting

The following illustrates temporary and final tightening sequences for components fastened to a heat sink using four screws. The illustration labels are for your assistance. Drive components do not carry these labels.

Figure 3.2
Four-Point Mounting

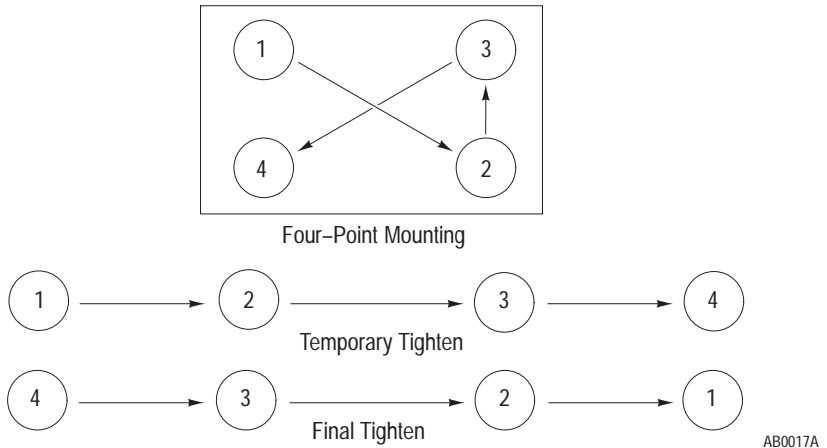

Torque Specifications

The following table lists fastener locations by component, how the fasteners are used, and torque specifications. Refer to Torque Sequence in this chapter for fastening two-point and four-point components to the heat sink.

Table 3.A
Fastener Torque Specifications

Component	Fastener Application	Torque, lb-in.	Torque, N-m
Bus Capacitor	Wires to terminals	45 – 55	5.1 – 6.2
Balancing Resistors	Resistors to fan housing	2.6 – 3.0	0.29 – 0.30
SCR Modules	Wires to terminals	70 – 90	7.9 – 10.1
SCR Modules	SCR to heat sink	35 – 40	3.4 – 4.5
Transistor Modules X1 – X6	C and E terminal wires	22 – 31	2.5 – 3.6
Transistor Modules X1 – X6	Module to heat sink	22 – 31	2.5 – 3.6
Transistor Modules X1 – X6	B and Bx terminal wires	9 – 15	1.0 – 1.7
Snubbers	Snubbers to transistors	9 – 15	1.0 – 1.7
Terminal Strip TB1, M1 – M3, L1 – L3	Wires to terminals	375	42
Terminal Strip TB1, +DC, -DC	Wires to terminals	275	31
Terminal Strip TB2	Wires to terminals	7	0.8
Terminal Strip TB3	Wires to terminals	7	0.8
Bus Resistors	Resistors to Bus Bar	2.6 – 3.0	0.29 – 0.30

Major Component Replacement

This section explains in detail how to replace the following drive components:

- Precharge Resistors
- SCR module
- Thermostat ST
- Transistor modules and snubbers
- Ground Sense CT
- Surge Suppressor MOV1
- Fan
- Transformer T1
- DC Bus Inductor L1
- Bus capacitors
- Bus Sense Module
- LEM A and LEM C
- Bus Diode D1
- Bus Fuse F1

For Main Control Board, Base Driver/Power Supply Board, Programming and Display Board, Precharge Board, and Main Bus Bar assembly installation and removal procedures, refer to Chapter 2.

Precharge Resistors

Two Precharge Resistors are located on the Fan Housing.

Figure 3.3
Precharge Resistors

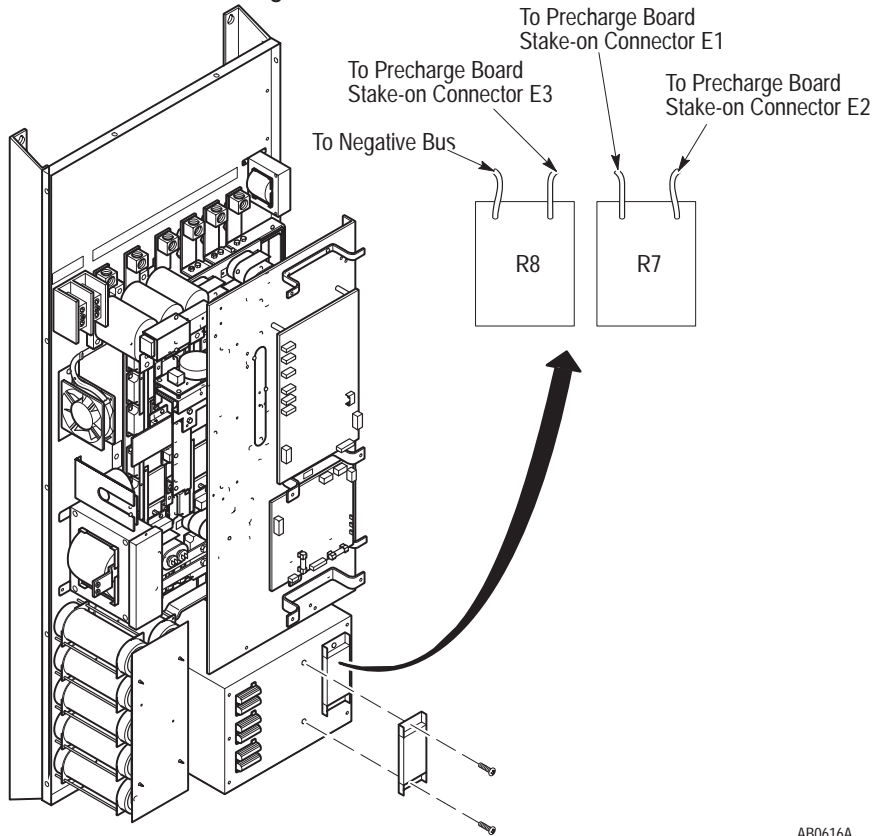

AB0616A

Removal



ATTENTION: Disconnect and lock out power from the drive before disassembling the drive. Failure to disconnect power may result in death or serious injury. A bus charge neon indicator provides visual indication that bus voltage is present. Verify bus voltage by measuring the voltage between +DC and -DC on Terminal Block TB1. Do not attempt to service the drive until the neon indicator has extinguished and the bus voltage has discharged to zero volts.



ATTENTION: Wear a wrist-type grounding strap when servicing 1336 Drives. Failure to protect drive components against ESD may damage drive components. Refer to Electrostatic Discharge Precautions at the beginning of this chapter.

IMPORTANT: Before you remove connections, bus bars, and wires from the drive components, mark the connections, bus bars, and wires to correspond with their component connections and terminals to prevent incorrect wiring during assembly.

1. Remove power from the drive.
2. Wait for the Bus Indicator Light DS1 to turn off. Check for zero volts at TB1 Terminals +DC and –DC before proceeding.
3. Remove the two screws fastening the Precharge Resistor to the Fan Housing.
4. Remove the Precharge Resistor wires from the following:
 - Precharge Board stake-on connectors
 - Negative Bus (R8 only)

Installation

1. Clean the surfaces between the Precharge Resistor and the Fan Housing.
2. Install the Precharge Resistor in reverse order of removal.



ATTENTION: Replace all guards before applying power to the drive. Failure to replace guards may result in death or serious injury.

SCR Modules

SCR1, SCR2, and SCR3 are located behind the Base Driver Mounting Plate and below the Transistor Module. These rectifiers are listed in Chapter 4 – Spare Parts List as BR1, BR2, and BR3.

Figure 3.4
SCR Modules

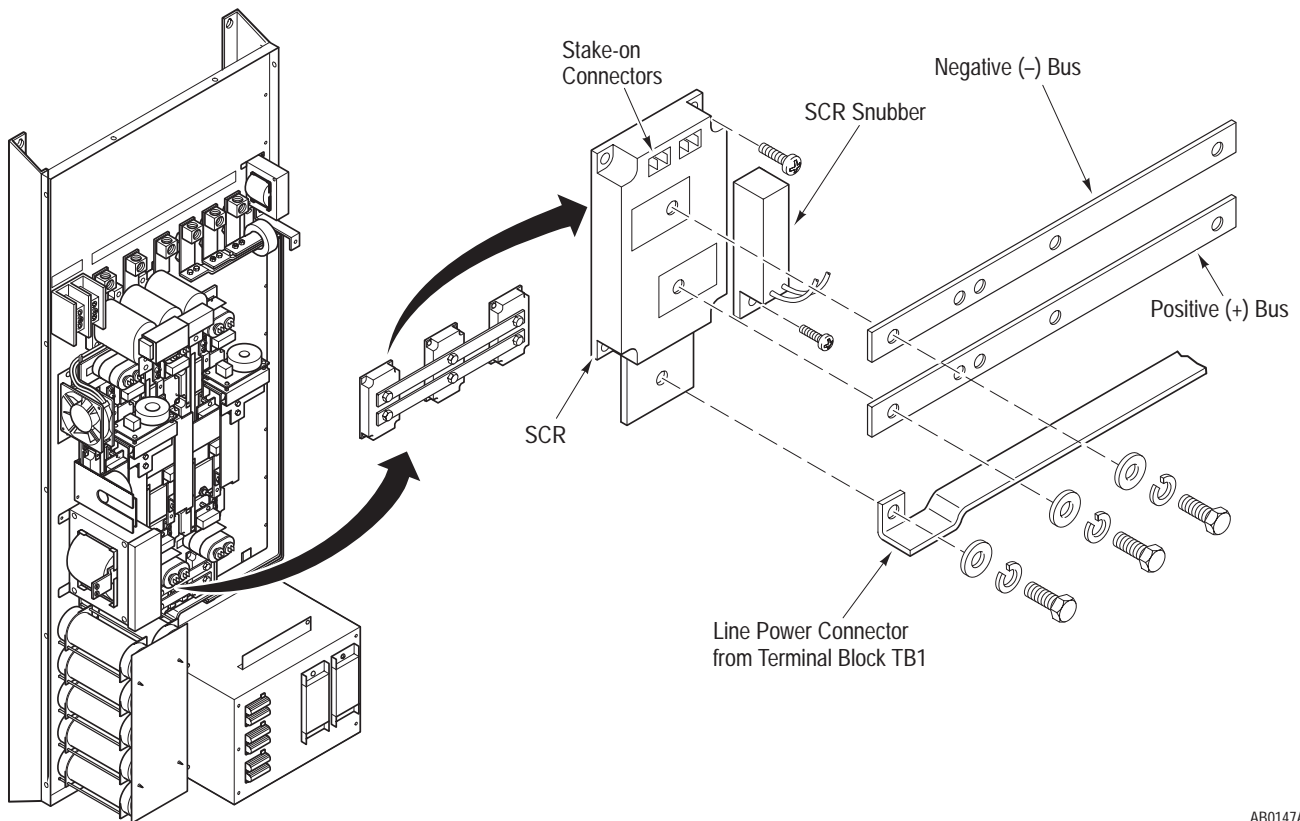

AB0147A

Removal



ATTENTION: Disconnect and lock out power from the drive before disassembling the drive. Failure to disconnect power may result in death or serious injury. A bus charge neon indicator provides visual indication that bus voltage is present. Verify bus voltage by measuring the voltage between +DC and -DC on Terminal Block TB1. Do not attempt to service the drive until the neon indicator has extinguished and the bus voltage has discharged to zero volts.



ATTENTION: Wear a wrist-type grounding strap when servicing 1336 Drives. Failure to protect drive components against ESD may damage drive components. Refer to Electrostatic Discharge Precautions at the beginning of this chapter.

IMPORTANT: Before you remove connections, bus bars, and wires from the drive components, mark the connections, bus bars, and wires to correspond with their component connections and terminals to prevent incorrect wiring during assembly.

1. Remove power from the drive.
2. Wait for Bus Indicator Light DS1 to turn off. Check for zero volts at TB1 Terminals +DC and –DC before proceeding.
3. Remove the Base Driver Mounting Plate from the drive. Refer to Chapter 2 – Removing the Base Driver Mounting Plate.
4. Remove the screws fastening the DC Bus Inductor L1 negative wire to the negative (upper) SCR terminal bus bar.
5. Remove the screws fastening the Bus Fuse positive wire to the positive (lower) SCR terminal bus bar.
6. Remove the screws fastening the SCR bus bars to the SCR terminals.
7. Remove the wires from the SCR stake-on connectors.
8. Remove the screws fastening the SCR Snubber to the heat sink.
9. Remove the screws fastening the malfunctioned SCR snubber wires to the SCR positive and negative bus bars.
10. Remove the screws fastening the malfunctioned SCR to the heat sink.

Installation

1. Clean the surfaces between the SCR and the heat sink.
2. Replace the Preform between the SCR and the heat sink.
3. Install SCR in reverse order of removal. Always replace the SCR Snubbers when replacing an SCR.



ATTENTION: Replace all guards before applying power to the drive. Failure to replace guards may result in death or serious injury.

Thermostat ST

Thermostat ST is located behind the Base Driver Mounting Plate and is fastened to the upper middle area of the heat sink, near the Transistor Snubbers.

Figure 3.5
Thermostat ST

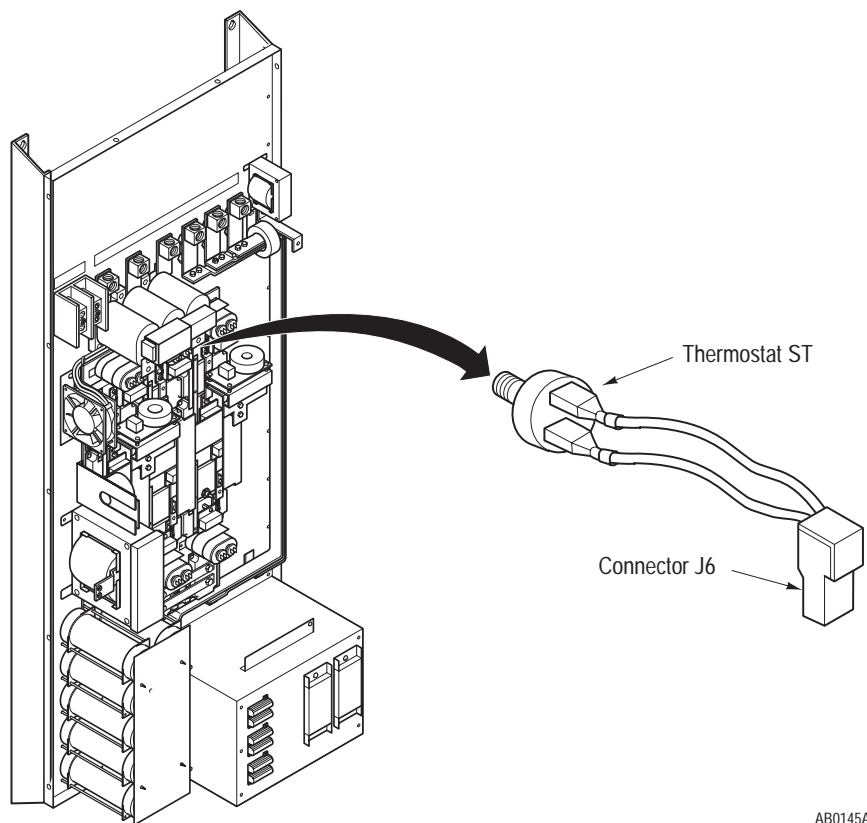

AB0145A

Removal



ATTENTION: Disconnect and lock out power from the drive before disassembling the drive. Failure to disconnect power may result in death or serious injury. A bus charge neon indicator provides visual indication that bus voltage is present. Verify bus voltage by measuring the voltage between +DC and -DC on Terminal Block TB1. Do not attempt to service the drive until the neon indicator has extinguished and the bus voltage has discharged to zero volts.



ATTENTION: Wear a wrist-type grounding strap when servicing 1336 Drives. Failure to protect drive components against ESD may damage drive components. Refer to Electrostatic Discharge Precautions at the beginning of this chapter.

IMPORTANT: Before you remove connections, bus bars, and wires from the drive components, mark the connections, bus bars, and wires to correspond with their component connections and terminals to prevent incorrect wiring during assembly.

1. Remove power from the drive.
2. Wait for Bus Indicator Light DS1 to turn off. Check for zero volts at TB1 Terminals +DC and –DC before proceeding.
3. Remove the Base Driver Mounting Plate from the drive. Refer to Chapter 2 – Removing the Base Driver Mounting Plate.
4. Remove the two wires from the Thermostat ST stake-on connectors.
5. Unscrew the thermostat from the heat sink.

Installation

Install Thermostat ST1 in reverse order of removal.

IMPORTANT: When fastening the thermostat to the heat sink, hand-tighten the thermostat to avoid damaging the porcelain thermostat body.



ATTENTION: Replace all guards before applying power to the drive. Failure to replace guards may result in death or serious injury.

Transistor Modules and Snubbers

Transistor Modules and snubbers are located on the heat sink, behind the Base Driver Mounting Plate and behind the Main Bus Bar assembly.

Figure 3.6
Transistor Modules and Snubbers

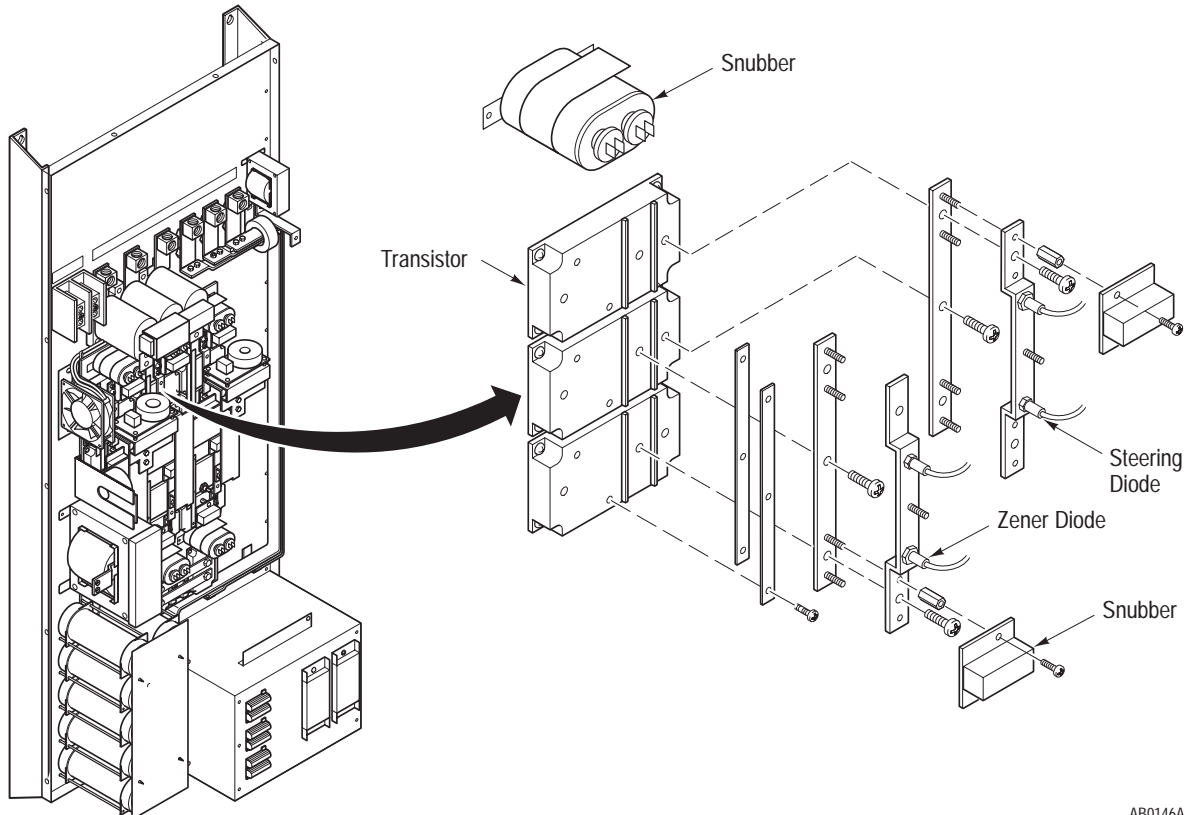

AB0146A

Removal



ATTENTION: Disconnect and lock out power from the drive before disassembling the drive. Failure to disconnect power may result in death or serious injury. A bus charge neon indicator provides visual indication that bus voltage is present. Verify bus voltage by measuring the voltage between +DC and -DC on Terminal Block TB1. Do not attempt to service the drive until the neon indicator has extinguished and the bus voltage has discharged to zero volts.



ATTENTION: Wear a wrist-type grounding strap when servicing 1336 Drives. Failure to protect drive components against ESD may damage drive components. Refer to Electrostatic Discharge Precautions at the beginning of this chapter.

IMPORTANT: Before you remove connections, bus bars, and wires from the drive components, mark the connections, bus bars, and wires to correspond with their component connections and terminals to prevent incorrect wiring during assembly.

1. Remove power from the drive.
2. Wait for Bus Indicator Light DS1 to turn off. Check for zero volts at TB1 Terminals +DC and –DC before proceeding.
3. Remove the Main Bus Bar assembly. Refer to Chapter 2 – Removing the Main Bus Bar Assembly.
4. Remove the larger Transistor Snubber:
 - a. Remove the wires from the snubber stake-on connectors.
 - b. Remove the screws fastening the snubber bracket to the heat sink.
 - c. Loosen the snubber bracket retaining screw. For installation, note that the bottom of the snubber is not flush with the bracket base, but is flush with the bottom edge of the bracket's retaining strap that wraps around the snubber. The snubber must not touch the heat sink.
 - d. Pull the snubber out of the bracket.
5. Remove the snubber connected to the malfunctioned transistor:
 - a. Remove the Zener Diode wire from Transistor Snubber Stake-on Connector E2.
 - b. Remove the screws fastening the snubber to the transistor.
6. Remove the screws fastening tops and bottoms of the Transistor Diode bus bars to the malfunctioned Transistor Terminals C and E bus bars.
7. Remove the nuts and Transistor Snubber standoffs fastening the tops and bottoms of the Transistor Diode bus bars to the Transistor Terminals C and E bus bars.
8. Remove the Transistor Diode bus bars from the drive.
9. Remove the screws fastening the Transistor Terminal C and E bus bars to the transistors.
10. Remove the screws fastening the Transistor Terminal B and Bx bus bars to the transistors.
11. Remove the screws fastening the malfunctioned transistor to the heat sink.

Figure 3.7
Upper Transistor Group Steering Diodes

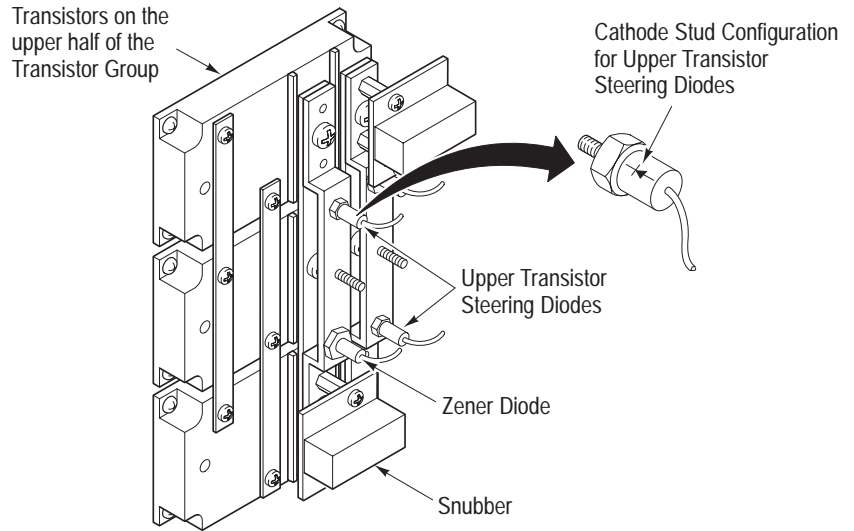

AB0157B

Figure 3.8
Lower Transistor Group Steering Diodes

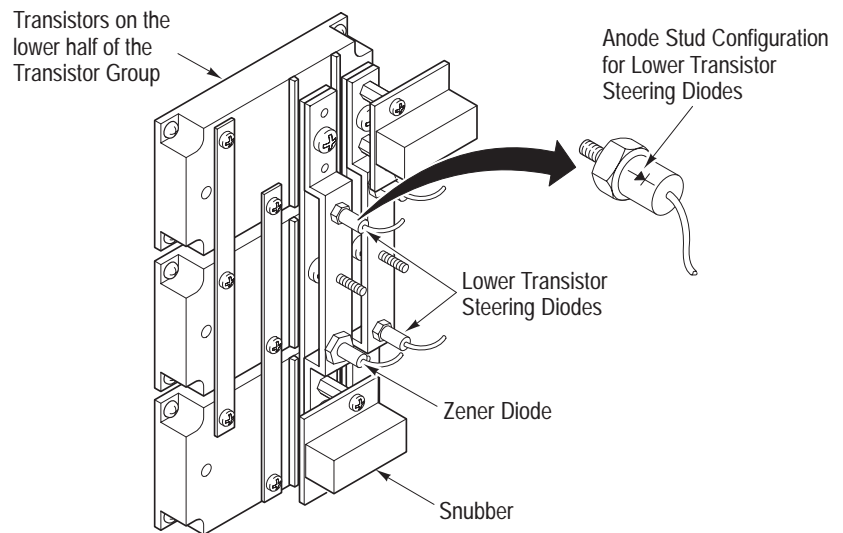

AB0158B

12. Remove the Zener Diodes and the Steering Diodes from the Transistor Diode bus bars.

IMPORTANT: For installation and replacement, note that the cathode configuration on the Steering Diodes for the upper transistor group differs from the cathode configuration for the Steering Diodes on the lower transistor group. The former illustrations show cathode configurations.

13. Remove the screws fastening the malfunctioned resistor to the resistor heat sink on the Main Bus Bar assembly.

Installation

1. Clean the surfaces between the transistor and the heat sink.
2. Replace the Preform between the transistor and the heat sink.
3. Install the transistor in reverse order of removal.

IMPORTANT: When you replace transistors and snubbers, always replace the Transistor Snubbers and diodes for the replaced transistor. Note that the larger snubbers should not touch the heat sink. Mount the base of these snubbers flush with the bottom of their snubber bracket retaining straps.



ATTENTION: Replace all guards before applying power to the drive. Failure to replace guards may result in death or serious injury.

Ground Sense CT

Ground Sense CT is located on the Main Chassis above the Main Control Board.

Figure 3.9
Ground Sense C

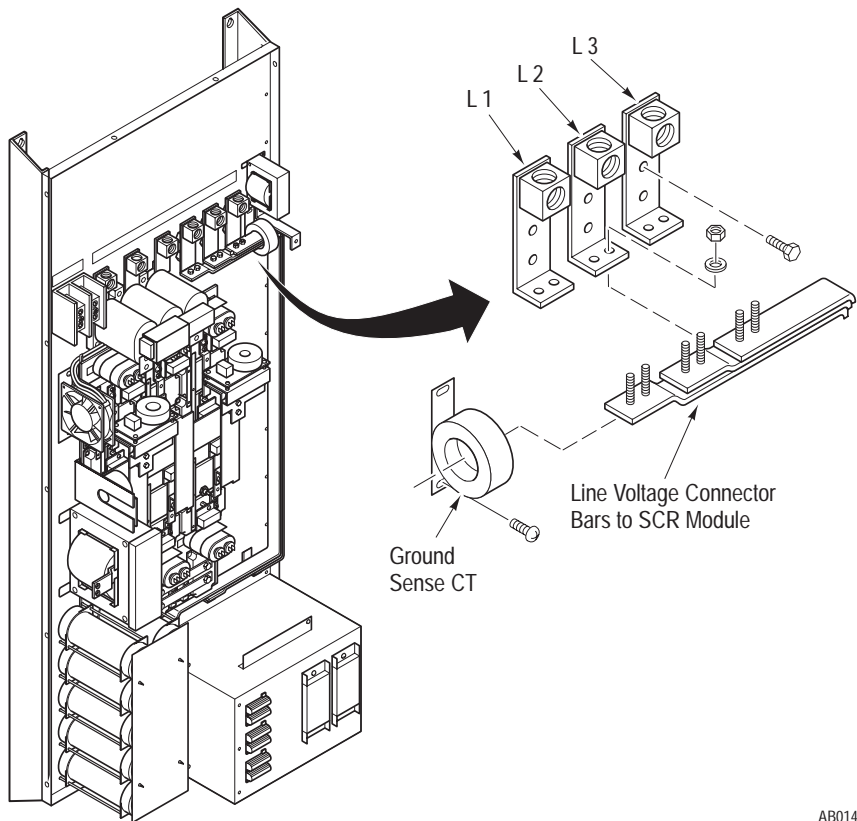

AB0143A

Removal



ATTENTION: Disconnect and lock out power from the drive before disassembling the drive. Failure to disconnect power may result in death or serious injury. A bus charge neon indicator provides visual indication that bus voltage is present. Verify bus voltage by measuring the voltage between +DC and -DC on Terminal Block TB1. Do not attempt to service the drive until the neon indicator has extinguished and the bus voltage has discharged to zero volts.



ATTENTION: Wear a wrist-type grounding strap when servicing 1336 Drives. Failure to protect drive components against ESD may damage drive components. Refer to Electrostatic Discharge Precautions at the beginning of this chapter.

IMPORTANT: Before you remove connections, bus bars, and wires from the drive components, mark the connections, bus bars, and wires to correspond with their component connections and terminals to prevent incorrect wiring during assembly.

1. Remove power from the drive.
2. Wait for Bus Indicator Light DS1 to turn off. Check for zero volts at TB1 Terminals +DC and –DC before proceeding.
3. Remove the Base Driver Mounting Plate from the drive. Refer to Chapter 2 – Removing the Base Driver Mounting Plate.
4. Remove the nuts fastening the line voltage connection bars to Terminals L1, L2, and L3. The line voltage connection bars connect L1, L2, and L3 to the SCR Module.
5. Remove the screws fastening Terminals L1, L2, and L3 to the chassis standoffs.
6. Remove the two screws fastening Ground Sense CT to the Main Chassis.
7. Slide Ground Sense CT off of the Terminals L1, L2, and L3 line voltage connection bars.

Installation

Install Ground Sense CT in reverse order of removal.

IMPORTANT: Slide the Ground Sense CT over the Terminal L1, L2, and L3 line voltage connection bars before fastening the L1, L2, and L3 terminals to the chassis standoffs. The power connection bars connect the SCR Modules to Terminals L1, L2, and L3.



ATTENTION: Replace all guards before applying power to the drive. Failure to replace guards may result in death or serious injury.

Surge Suppressor MOV1

Surge Suppressor MOV1 is located behind the Base Driver Mounting Plate, near Transformer T1 and Terminal Block TB1.

Figure 3.10
Surge Suppressor MOV1

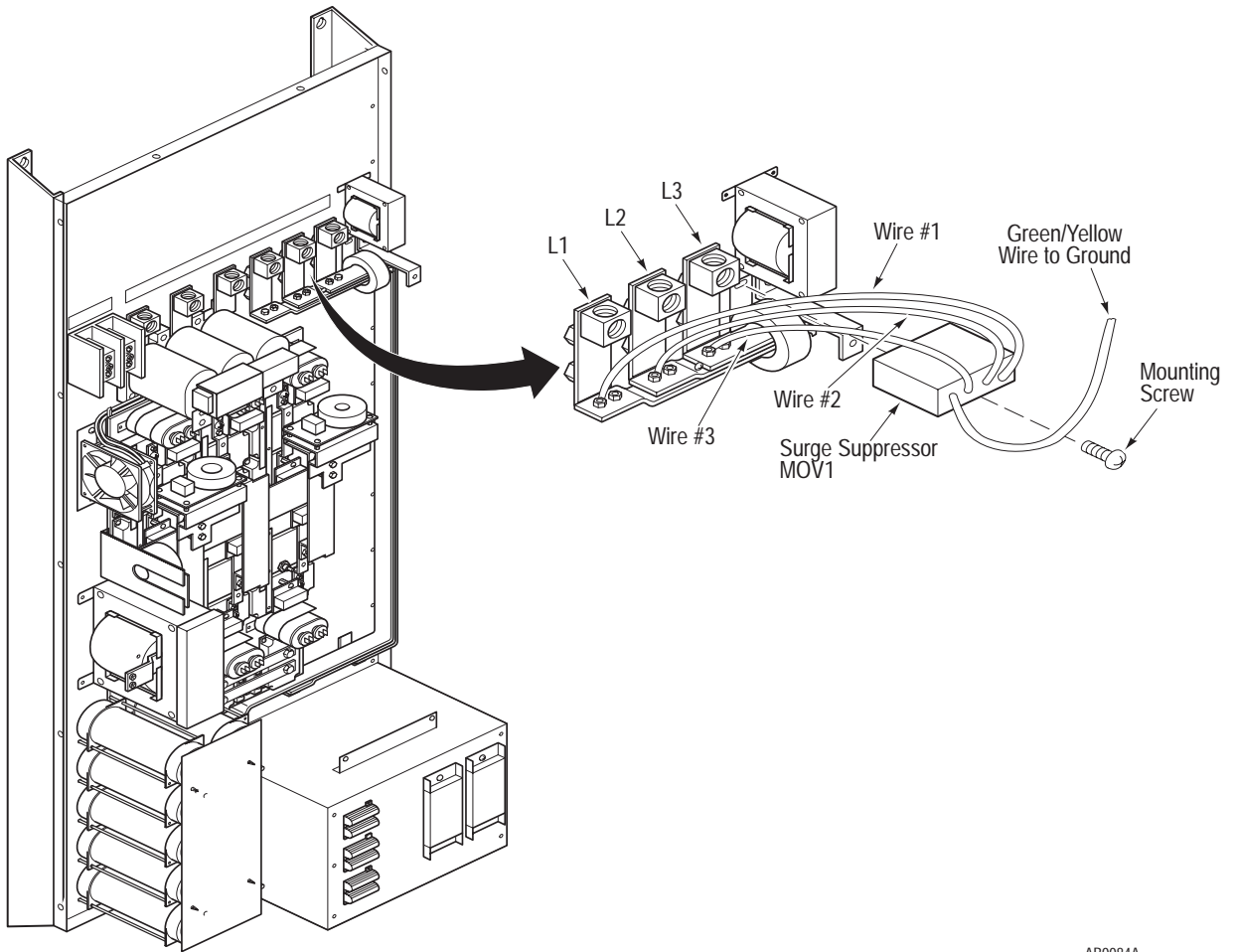

AB0084A

Removal



ATTENTION: Disconnect and lock out power from the drive before disassembling the drive. Failure to disconnect power may result in death or serious injury. A bus charge neon indicator provides visual indication that bus voltage is present. Verify bus voltage by measuring the voltage between +DC and –DC on Terminal Block TB1. Do not attempt to service the drive until the neon indicator has extinguished and the bus voltage has discharged to zero volts.



ATTENTION: Wear a wrist-type grounding strap when servicing 1336 Drives. Failure to protect drive components against ESD may damage drive components. Refer to Electrostatic Discharge Precautions at the beginning of this chapter.

IMPORTANT: Before you remove connections, bus bars, and wires from the drive components, mark the connections, bus bars, and wires to correspond with their component connections and terminals to prevent incorrect wiring during assembly.

1. Remove power from the drive.
2. Wait for Bus Indicator Light DS1 to turn off. Check for zero volts at TB1 Terminals +DC and –DC before proceeding.
3. Remove the Base Driver Mounting Plate. Refer to Chapter 2 – Removing the Base Driver Mounting Plate.
4. Remove MOV1 wires from the following:
 - Yellow/green wire from the ground location on the top right corner of the Main Chassis.
 - Wire #1 from TB1, Terminal L1
 - Wire #2 from TB1, Terminal L2
 - Wire #3 from TB1, Terminal L3
5. Remove the screw fastening MOV1 to the drive.

Installation

Install Surge Suppressor MOV1 in reverse order of removal. Note that the neutral-ground wire on the new MOV1 is yellow on green.



ATTENTION: Replace all guards before applying power to the drive. Failure to replace guards may result in death or serious injury.

Fan

The Fan is located behind and below the Base Driver Mounting Plate.

Figure 3.11
Fan

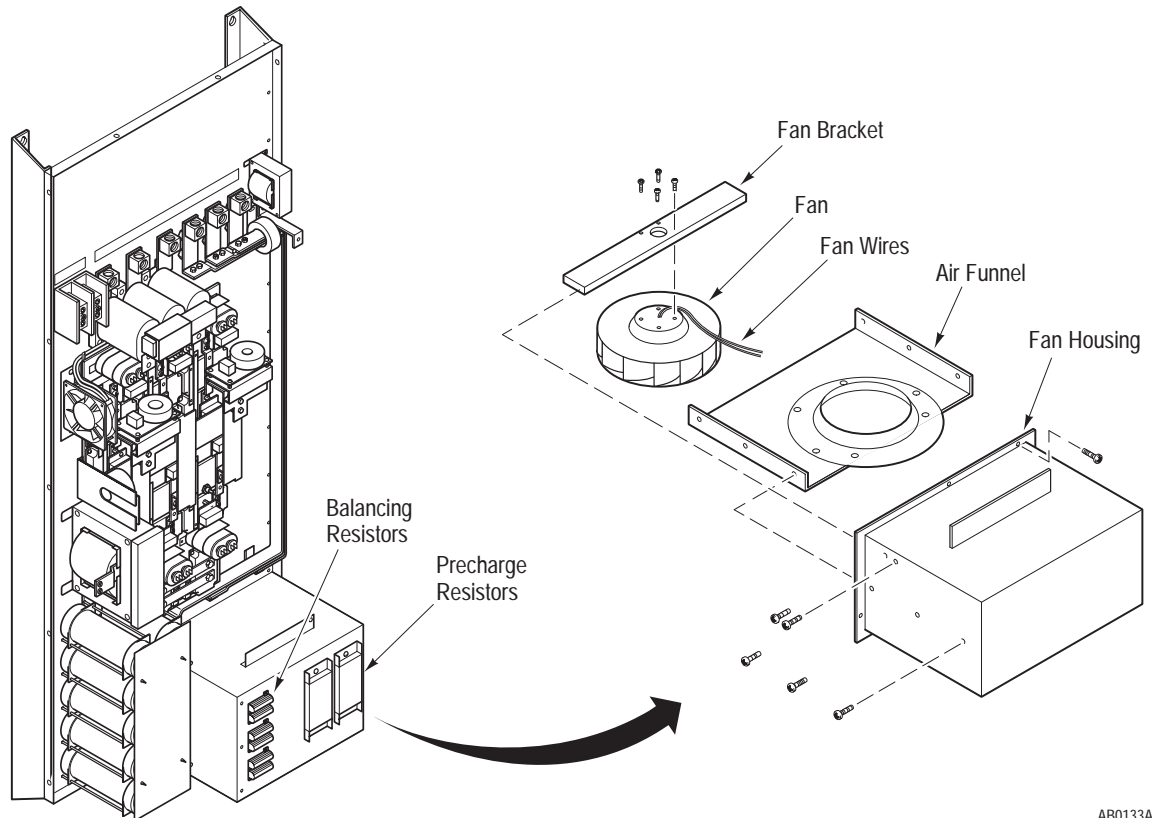

AB0133A

Removal



ATTENTION: Disconnect and lock out power from the drive before disassembling the drive. Failure to disconnect power may result in death or serious injury. A bus charge neon indicator provides visual indication that bus voltage is present. Verify bus voltage by measuring the voltage between +DC and -DC on Terminal Block TB1. Do not attempt to service the drive until the neon indicator has extinguished and the bus voltage has discharged to zero volts.



ATTENTION: Wear a wrist-type grounding strap when servicing 1336 Drives. Failure to protect drive components against ESD may damage drive components. Refer to Electrostatic Discharge Precautions at the beginning of this chapter.

IMPORTANT: Before you remove connections, bus bars, and wires from the drive components, mark the connections, bus bars, and wires to correspond with their component connections and terminals to prevent incorrect wiring during assembly.

1. Remove power from the drive.
2. Wait for Bus Indicator Light DS1 to turn off. Check for zero volts at TB1 Terminals +DC and –DC before proceeding.
3. Remove the Base Driver Mounting Plate from the drive. Refer to Chapter 2 – Removing the Base Driver Mounting Plate.
4. Remove the 0V and 115V wires from the terminal block located on the right side of the Fan Housing.
5. Remove the screws fastening the Balancing Resistor wires to the Bus Capacitors.
6. Remove the screw fastening the Precharge Resistor R8 wire to the SCR Module negative bus bar.
7. Remove the screws fastening the Fan Housing to the chassis.
8. Pull the Fan Housing away from the drive.
9. Place the Fan Housing on a surface with the open side of the housing facing up.
10. Cut all fan wires at the adjustable grommet, located on the side of the Fan Housing.
11. Remove the screws fastening the Air Funnel to the inside of the Fan Housing.
12. Remove the four screws fastening the horizontal Fan Bracket to the inside of the Fan Housing. Two screws are located near the top edge of each side of the Fan Housing.
13. Loosen the nut on the adjustable grommet and remove the wires from the grommet.
14. Remove the Fan from the Fan Housing.
15. Remove the wires from the Fan Capacitor stake-on connectors.
16. Remove the screws fastening the Fan Capacitor to the Fan Housing.

Installation

Figure 3.12
Fan Wiring

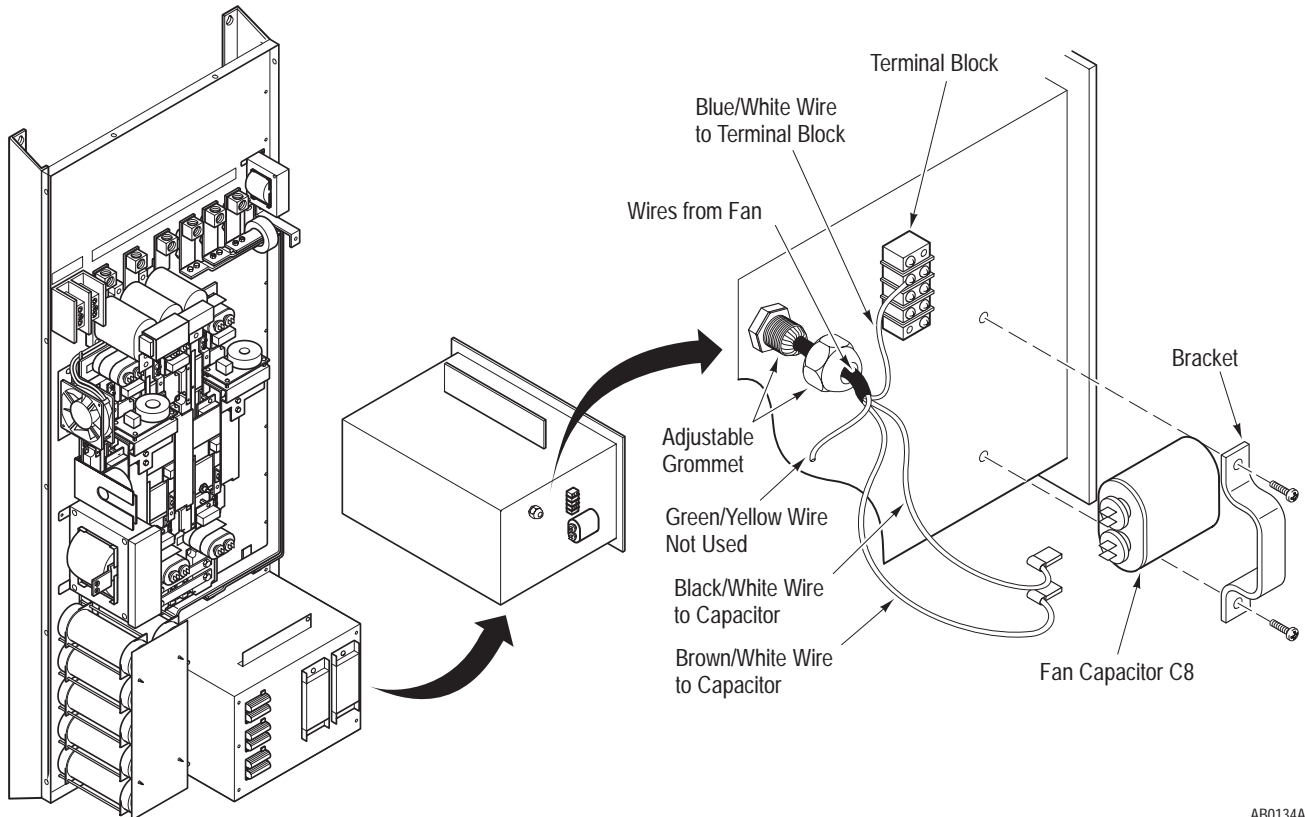

AB0134A

1. Feed the new Fan wires through the adjustable grommet, from the inside of the Fan Housing to the outside.
2. Cut off, insulate, and tie back the yellow-on-green Fan wire.
3. Fasten the wire terminals to the stripped ends of the Fan wires. Refer to the color schemes on the replaced Fan's wires for wire terminal placement.
4. Install the Fan and C8 in reverse order of removal.

IMPORTANT: Before you mount the Fan and Fan Housing on the drive, run the Fan in the housing with the Air Funnel installed. Adjust the Fan and the Air Funnel on their horizontal mounting brackets until the Fan and Air Funnel do not rub together. Note that the oblong adjustment holes on the Fan Bracket are perpendicular to the holes on the Air Funnel Bracket.



ATTENTION: Replace all guards before applying power to the drive. Failure to replace guards may result in death or serious injury.

Transformer T1

Transformer T1 is located on the upper right corner of the Main Chassis, to the right of TB1 and MOV1.

Figure 3.13
Transformer T1

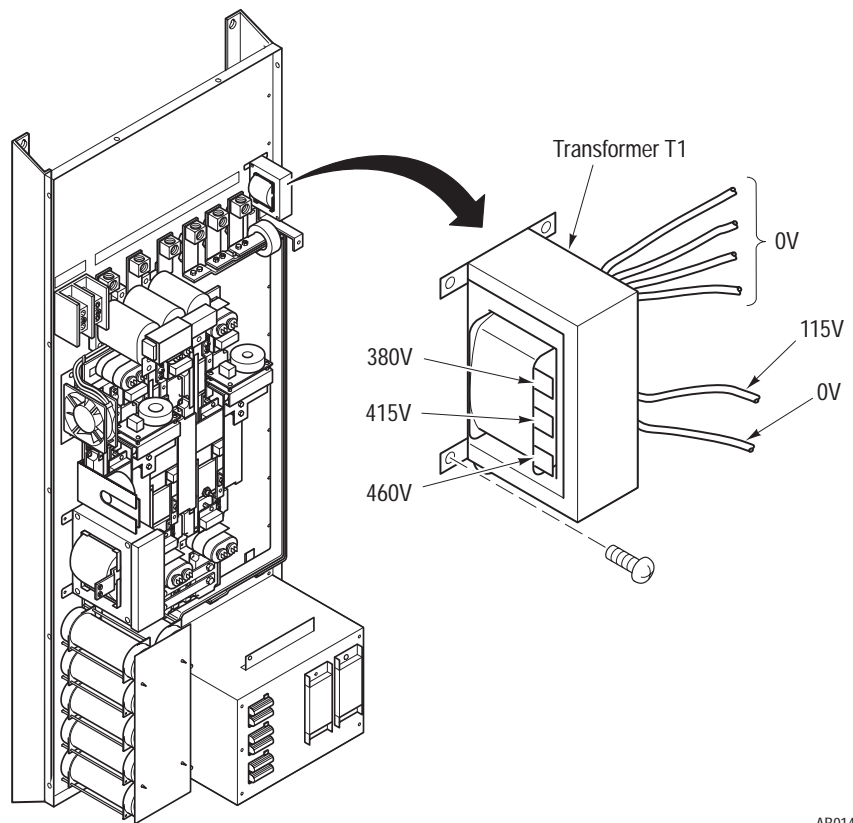

AB0144A

Removal



ATTENTION: Disconnect and lock out power from the drive before disassembling the drive. Failure to disconnect power may result in death or serious injury. A bus charge neon indicator provides visual indication that bus voltage is present. Verify bus voltage by measuring the voltage between +DC and -DC on Terminal Block TB1. Do not attempt to service the drive until the neon indicator has extinguished and the bus voltage has discharged to zero volts.



ATTENTION: Wear a wrist-type grounding strap when servicing 1336 Drives. Failure to protect drive components against ESD may damage drive components. Refer to Electrostatic Discharge Precautions at the beginning of this chapter.

IMPORTANT: Before you remove connections, bus bars, and wires from the drive components, mark the connections, bus bars, and wires to correspond with their component connections and terminals to prevent incorrect wiring during assembly.

1. Remove power from the drive.
2. Wait for Bus Indicator Light DS1 to turn off. Check for zero volts at TB1 Terminals +DC and –DC before proceeding.
3. Remove the Base Driver Mounting Plate from the drive. Refer to Chapter 2 – Removing the Base Driver Mounting Plate.
4. Remove the transformer 0V and 115V wires from the terminal block on the right side of the Fan Housing. The Fan Housing is located at the bottom of the drive.
5. Remove the 0V wire from Terminal Block TB1, Terminal L1.
6. Remove the wire from Transformer T1 380V, 415V, or 460V stake-on connector.
7. Remove the screws fastening T1 to the Main Chassis.
8. Remove the mounting brackets from T1.

Installation

Install Transformer T1 in reverse order of removal. Insulate and tie back any unused T1 voltage taps.



ATTENTION: Replace all guards before applying power to the drive. Failure to replace guards may result in death or serious injury.

DC Bus Inductor L1

DC Bus Inductor L1 is located on the left side of the Main Chassis. You do not need to remove the Base Driver Mounting Plate to access DC Bus Inductor L1.

Figure 3.14
DC Bus Inductor L1

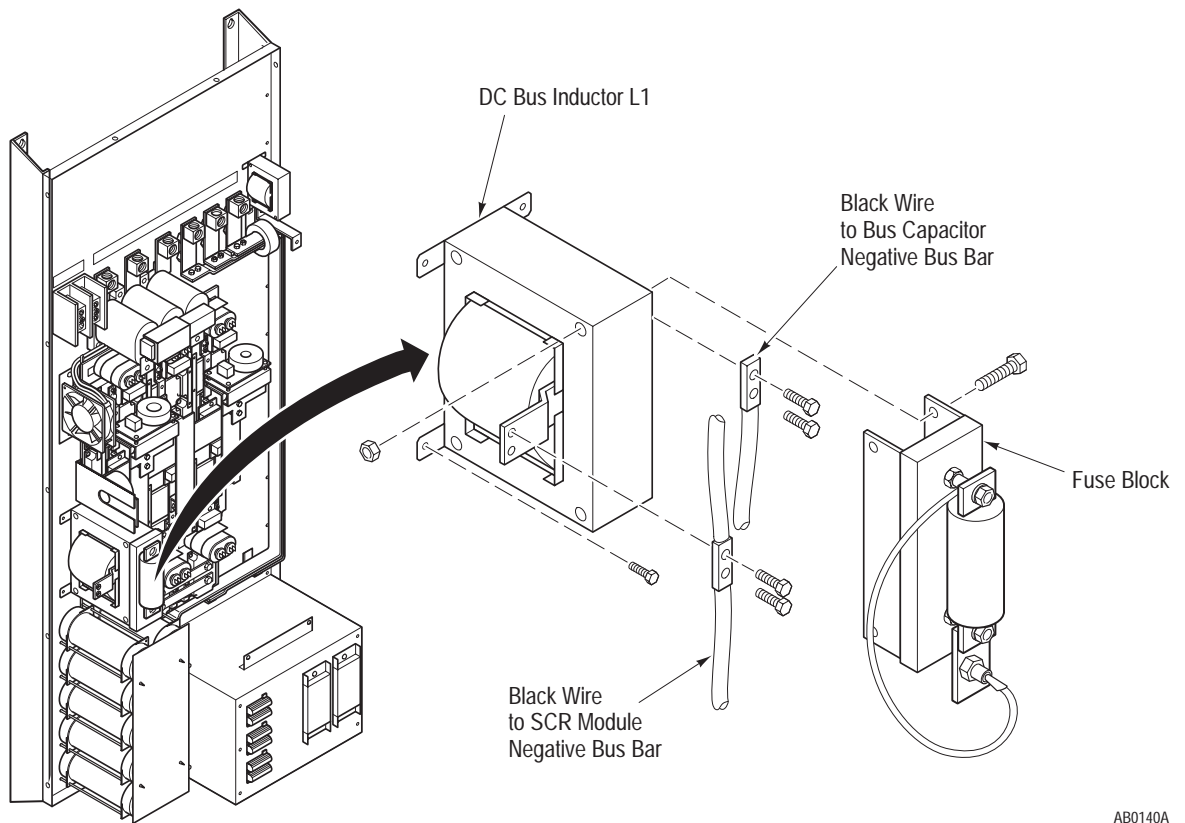

AB0140A

Removal



ATTENTION: Disconnect and lock out power from the drive before disassembling the drive. Failure to disconnect power may result in death or serious injury. A bus charge neon indicator provides visual indication that bus voltage is present. Verify bus voltage by measuring the voltage between +DC and -DC on Terminal Block TB1. Do not attempt to service the drive until the neon indicator has extinguished and the bus voltage has discharged to zero volts.



ATTENTION: Wear a wrist-type grounding strap when servicing 1336 Drives. Failure to protect drive components against ESD may damage drive components. Refer to Electrostatic Discharge Precautions at the beginning of this chapter.

IMPORTANT: Before you remove connections, bus bars, and wires from the drive components, mark the connections, bus bars, and wires to correspond with their component connections and terminals to prevent incorrect wiring during assembly.

1. Remove power from the drive.
2. Wait for Bus Indicator Light DS1 to turn off. Check for zero volts at TB1 Terminals +DC and –DC before proceeding.
3. Remove the screws fastening the Bus Fuse Block to the top of Inductor L1. These screws are located at the top corners of the inductor.
4. Remove the screws fastening the wires to the inductor.
5. Remove the screws fastening the inductor to the Main Chassis.
6. Remove the brackets from the inductor.

Installation

Install DC Bus Inductor L1 in reverse order of removal.



ATTENTION: Replace all guards before applying power to the drive. Failure to replace guards may result in death or serious injury.

Bus Capacitors

The bus capacitors are located on the lower left corner of the Main Chassis. You do not need to remove the Base Driver Mounting Plate to access the capacitors.

Figure 3.15
B150 – B200 Bus Capacitors

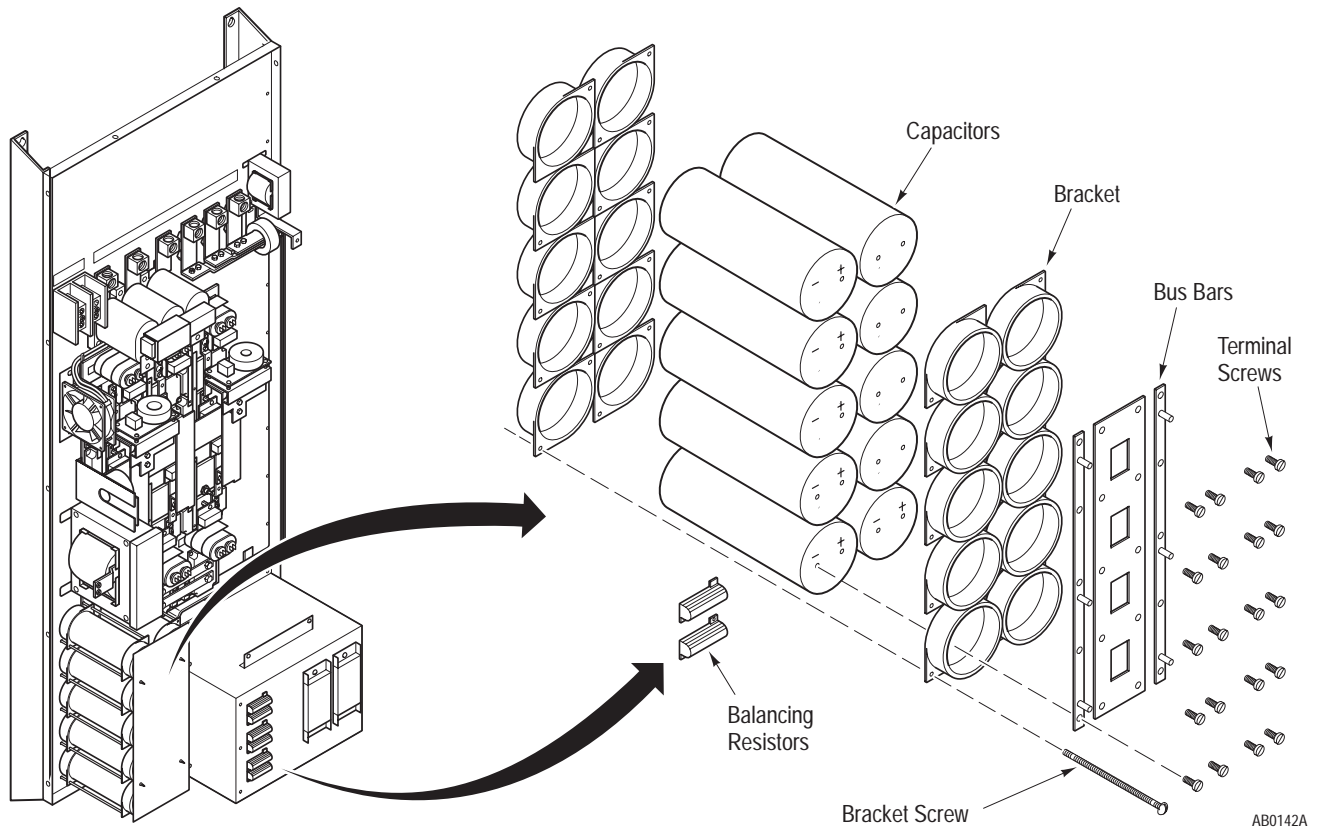
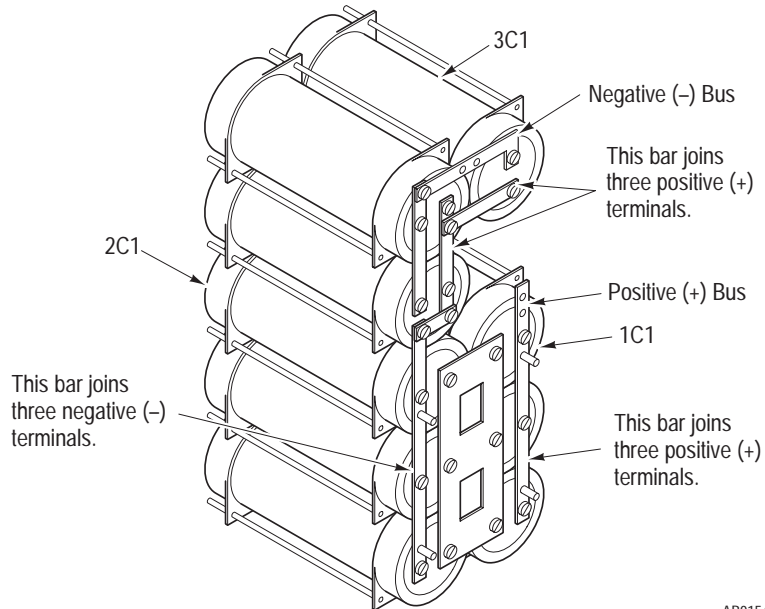

Figure 3.16
C150 – C200 Bus Capacitors



Removal



ATTENTION: Disconnect and lock out power from the drive before disassembling the drive. Failure to disconnect power may result in death or serious injury. A bus charge neon indicator provides visual indication that bus voltage is present. Verify bus voltage by measuring the voltage between +DC and -DC on Terminal Block TB1. Do not attempt to service the drive until the neon indicator has extinguished and the bus voltage has discharged to zero volts.



ATTENTION: Wear a wrist-type grounding strap when servicing 1336 Drives. Failure to protect drive components against ESD may damage drive components. Refer to Electrostatic Discharge Precautions at the beginning of this chapter.

IMPORTANT: Before you remove connections, bus bars, and wires from the drive components, mark the connections, bus bars, and wires to correspond with their component connections and terminals to prevent incorrect wiring during assembly.

1. Remove power from the drive.
2. Wait for Bus Indicator Light DS1 to turn off. Check for zero volts at TB1 Terminals +DC and –DC before proceeding.
3. Remove the protective shield covering the bus capacitor terminals.
4. Remove the nuts fastening the power wire connectors to the capacitor bus bars.
5. Remove the bus bars from the capacitor terminals.
6. Remove the bracket screws fastening the malfunctioned capacitor to the Main Chassis.
7. Remove the screws fastening the malfunctioned Balancing Resistor to the Fan Housing.

Installation

1. Loosely fasten the capacitors to the Main Chassis using the brackets and screws.
2. Loosely fasten all bus bars and wires to the capacitors.



ATTENTION: Any capacitors not connected correctly will explode and may cause death or serious injury. Refer to the former illustrations for capacitor and bus bar configuration.

3. Tighten the capacitor bracket screws.
4. Tighten the screws fastening the bus bars to the capacitors.
5. Tighten the wires to the bus bars.
6. Fasten the protective shield to cover the capacitor terminals.



ATTENTION: Replace all guards before applying power to the drive. Failure to replace guards may result in death or serious injury.

Bus Sense Module

The Bus Sense Module is located on the left side of the Main Chassis, near Bus Fuse F1. You do not need to remove the Base Driver Mounting Plate to access the Bus Sense Module.

Figure 3.17
Bus Sense Module

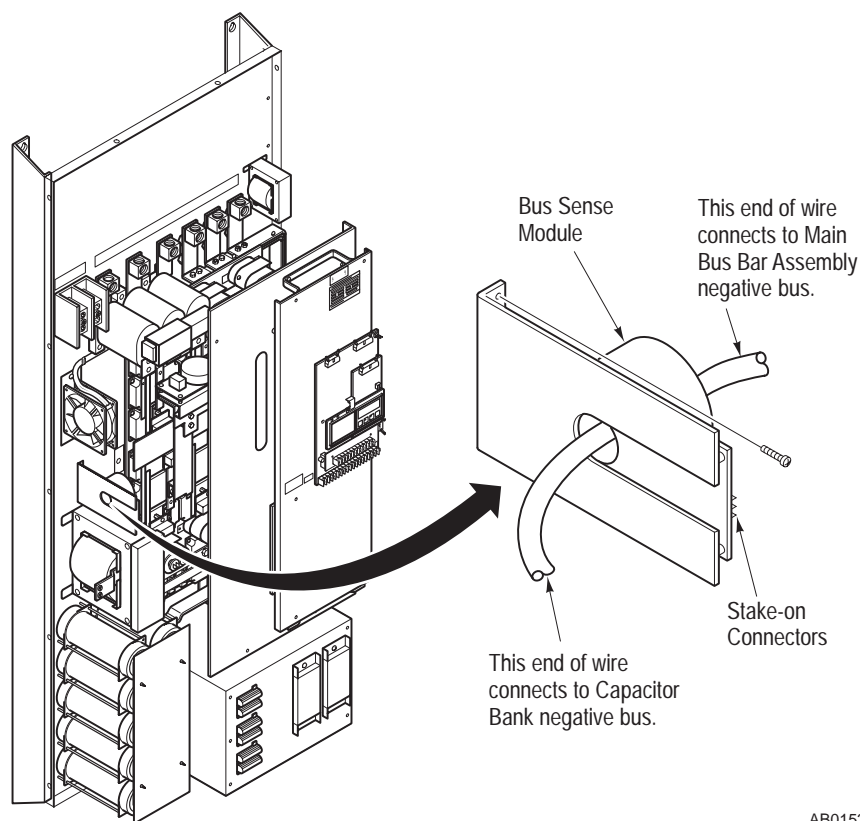

AB0152A

Removal



ATTENTION: Disconnect and lock out power from the drive before disassembling the drive. Failure to disconnect power may result in death or serious injury. A bus charge neon indicator provides visual indication that bus voltage is present. Verify bus voltage by measuring the voltage between +DC and -DC on Terminal Block TB1. Do not attempt to service the drive until the neon indicator has extinguished and the bus voltage has discharged to zero volts.



ATTENTION: Wear a wrist-type grounding strap when servicing 1336 Drives. Failure to protect drive components against ESD may damage drive components. Refer to Electrostatic Discharge Precautions at the beginning of this chapter.

IMPORTANT: Before you remove connections, bus bars, and wires from the drive components, mark the connections, bus bars, and wires to correspond with their component connections and terminals to prevent incorrect wiring during assembly.

1. Remove power from the drive.
2. Wait for Bus Indicator Light DS1 to turn off. Check for zero volts at TB1 Terminals +DC and –DC before proceeding. These terminals are located in the upper left corner of the drive.
3. Remove the wire from the –DC terminal on Terminal Block TB1, located on the upper left corner of the Main Chassis.
4. Remove the screws fastening the –DC wire to the Main Bus Bar assembly.
5. Pull the –DC wire through the hole in the Bus Sense Module.
6. Remove the wires from the Bus Sense Module stake-on connectors.
7. Remove the screws fastening the Bus Sense Module to the Main Chassis.

Installation

Install the Bus Sense Module in reverse order of removal.

IMPORTANT: Pass the –DC wire through the hole in the Bus Sense Module before you fasten the wire to the TB1 –DC terminal and the Main Bus Bar assembly. The arrow on the Bus Sense Module indicates the direction the –DC wire must travel as the wire passes through the Bus Sense Module and connects to the TB1 –DC terminal.

LEM A and LEM C

LEM A and LEM C are located on the Main Bus Bar assembly and behind the Base Driver Mounting Plate.

Figure 3.18
LEM A and LEM C

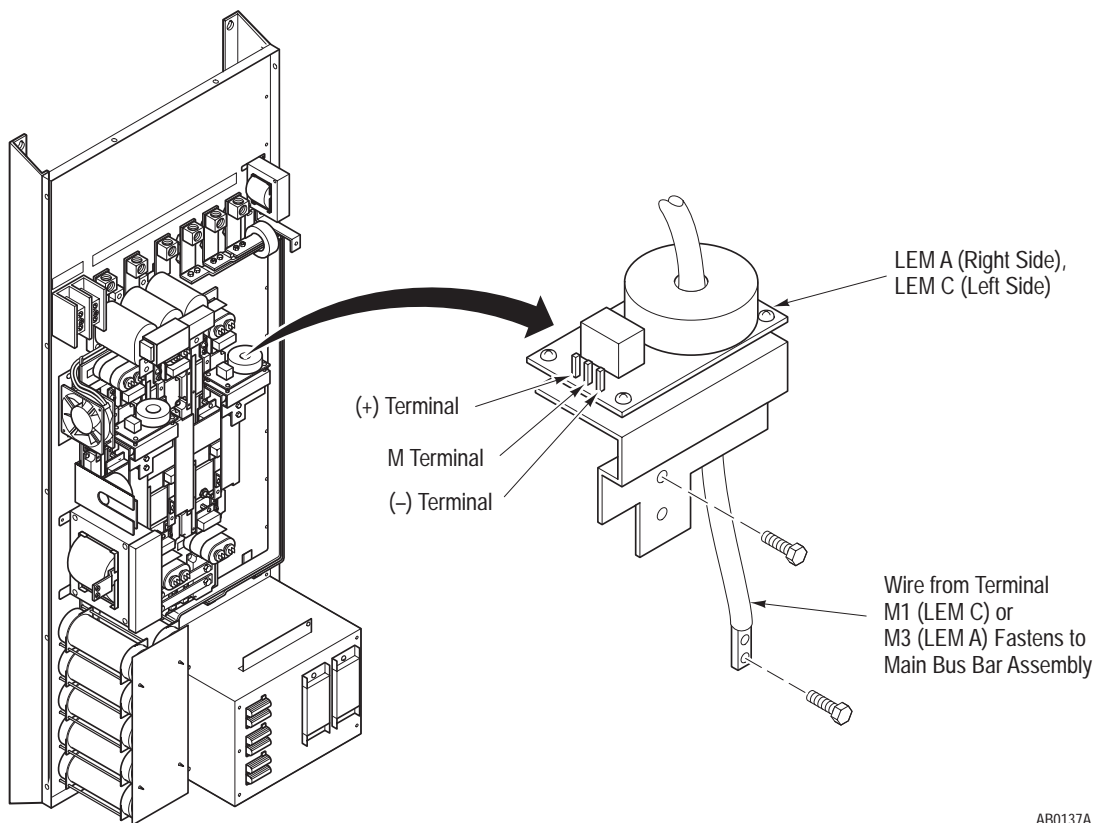

AB0137A

Removal



ATTENTION: Disconnect and lock out power from the drive before disassembling the drive. Failure to disconnect power may result in death or serious injury. A bus charge neon indicator provides visual indication that bus voltage is present. Verify bus voltage by measuring the voltage between +DC and -DC on Terminal Block TB1. Do not attempt to service the drive until the neon indicator has extinguished and the bus voltage has discharged to zero volts.



ATTENTION: Wear a wrist-type grounding strap when servicing 1336 Drives. Failure to protect drive components against ESD may damage drive components. Refer to Electrostatic Discharge Precautions at the beginning of this chapter.

IMPORTANT: Before you remove connections, bus bars, and wires from the drive components, mark the connections, bus bars, and wires to correspond with their component connections and terminals to prevent incorrect wiring during assembly.

1. Remove power from the drive.
2. Wait for Bus Indicator Light DS1 to turn off. Check for zero volts at TB1 Terminals +DC and –DC before proceeding.
3. Remove the Base Driver Mounting Plate from the drive. Refer to Chapter 2 – Removing the Base Driver Mounting Plate.
4. Remove the wire from TB1 Terminal:
 - M3 if you are replacing LEM A
 - M1 if you are replacing LEM C
5. Remove the wires from the malfunctioned LEM stake-on connectors.
6. Remove the screws fastening the malfunctioned LEM to the Main Bus Bar assembly.
7. Slide the malfunctioned LEM off of the M1 or M3 wire.

Installation

Install LEM A and LEM C in reverse order of removal.



ATTENTION: Replace all guards before applying power to the drive. Failure to replace guards may result in death or serious injury.

Bus Diode D1

Bus Diode D1 is located on a plate fastened to the lower connection of Bus Fuse F1. Bus Fuse F1 is located on top of DC Bus Inductor L1 on the left side of the Main Chassis. You do not need to remove the Base Driver Mounting Plate to access Bus Diode D1.

Figure 3.19
Bus Diode D1

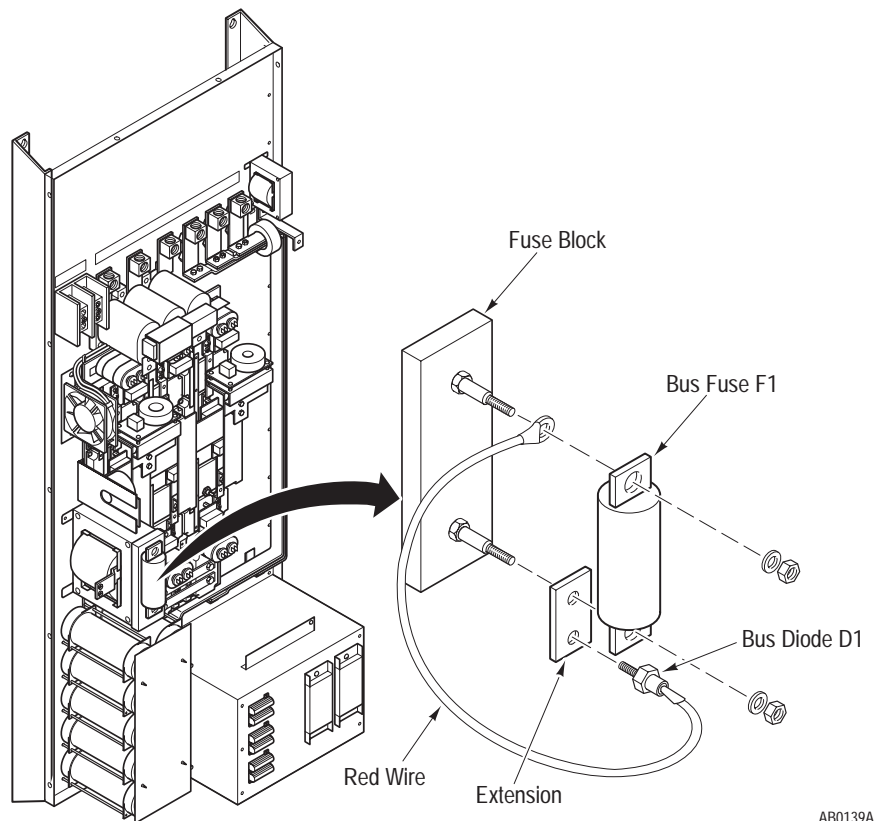

AB0139A

Removal



ATTENTION: Disconnect and lock out power from the drive before disassembling the drive. Failure to disconnect power may result in death or serious injury. A bus charge neon indicator provides visual indication that bus voltage is present. Verify bus voltage by measuring the voltage between +DC and -DC on Terminal Block TB1. Do not attempt to service the drive until the neon indicator has extinguished and the bus voltage has discharged to zero volts.



ATTENTION: Wear a wrist-type grounding strap when servicing 1336 Drives. Failure to protect drive components against ESD may damage drive components. Refer to Electrostatic Discharge Precautions at the beginning of this chapter.

IMPORTANT: Before you remove connections, bus bars, and wires from the drive components, mark the connections, bus bars, and wires to correspond with their component connections and terminals to prevent incorrect wiring during assembly.

1. Remove power from the drive.
2. Wait for Bus Indicator Light DS1 to turn off. Check for zero volts at TB1 Terminals +DC and –DC before proceeding.
3. Remove Bus Diode D1 from the extension located at the lower end of Bus Fuse F1.
4. Remove the nuts fastening Bus Fuse F1 to the fuse block.
5. Remove the Bus Diode D1 wire from the upper connection on the fuse block.

Installation

Install Bus Diode D1 in reverse order of removal.



ATTENTION: Replace all guards before applying power to the drive. Failure to replace guards may result in death or serious injury.

Bus Fuse F1

Bus Fuse F1 is located on top of DC Bus Inductor L1 on the left side of the Main Chassis. You do not need to remove the Base Driver Mounting Plate to access Bus Fuse F1.

Figure 3.20
Bus Fuse F1

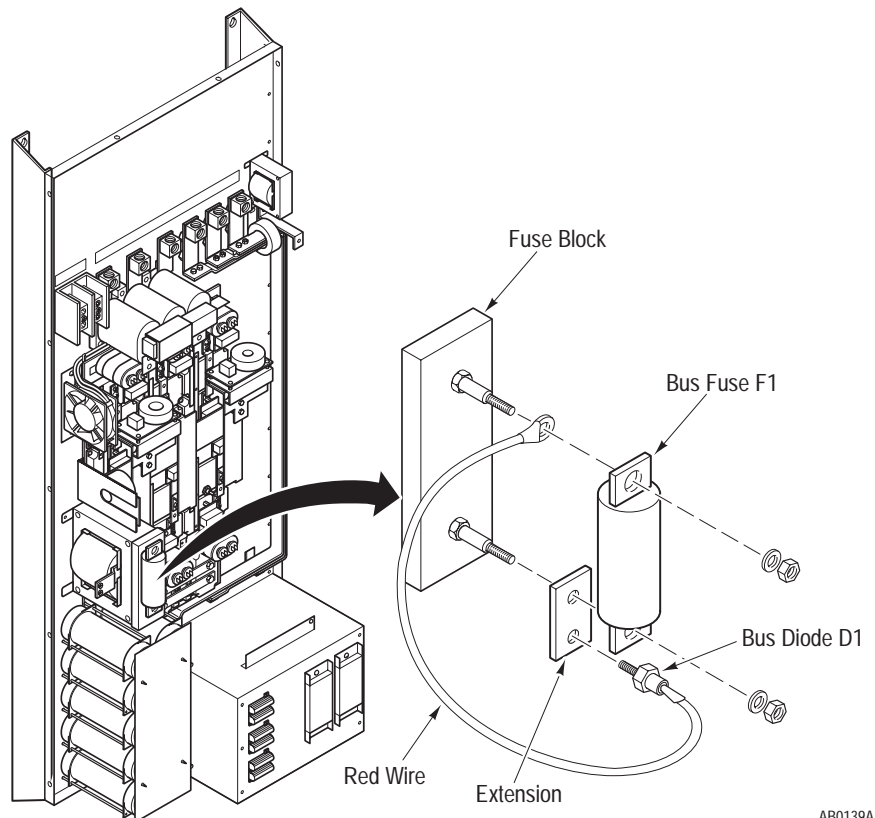

ATTENTION: Disconnect and lock out power from the drive before disassembling the drive. Failure to disconnect power may result in death or serious injury. A bus charge neon indicator provides visual indication that bus voltage is present. Verify bus voltage by measuring the voltage between +DC and -DC on Terminal Block TB1. Do not attempt to service the drive until the neon indicator has extinguished and the bus voltage has discharged to zero volts.



ATTENTION: Wear a wrist-type grounding strap when servicing 1336 Drives. Failure to protect drive components against ESD may damage drive components. Refer to Electrostatic Discharge Precautions at the beginning of this chapter.

IMPORTANT: Before you remove connections, bus bars, and wires from the drive components, mark the connections, bus bars, and wires to correspond with their component connections and terminals to prevent incorrect wiring during assembly.

1. Remove power from the drive.
2. Wait for Bus Indicator Light DS1 to turn off. Check for zero volts at TB1 Terminals +DC and –DC before proceeding.
3. Remove the nut fastening the bus diode wire to the fuse block.
4. Remove the nuts fastening Bus Fuse F1 to the fuse block to remove the fuse from the drive.

Installation

Install Bus Fuse F1 in reverse order of removal.



ATTENTION: Replace all guards before applying power to the drive. Failure to replace guards may result in death or serious injury.

Load Reactor LR

Figure 3.21
Load Reactor LR

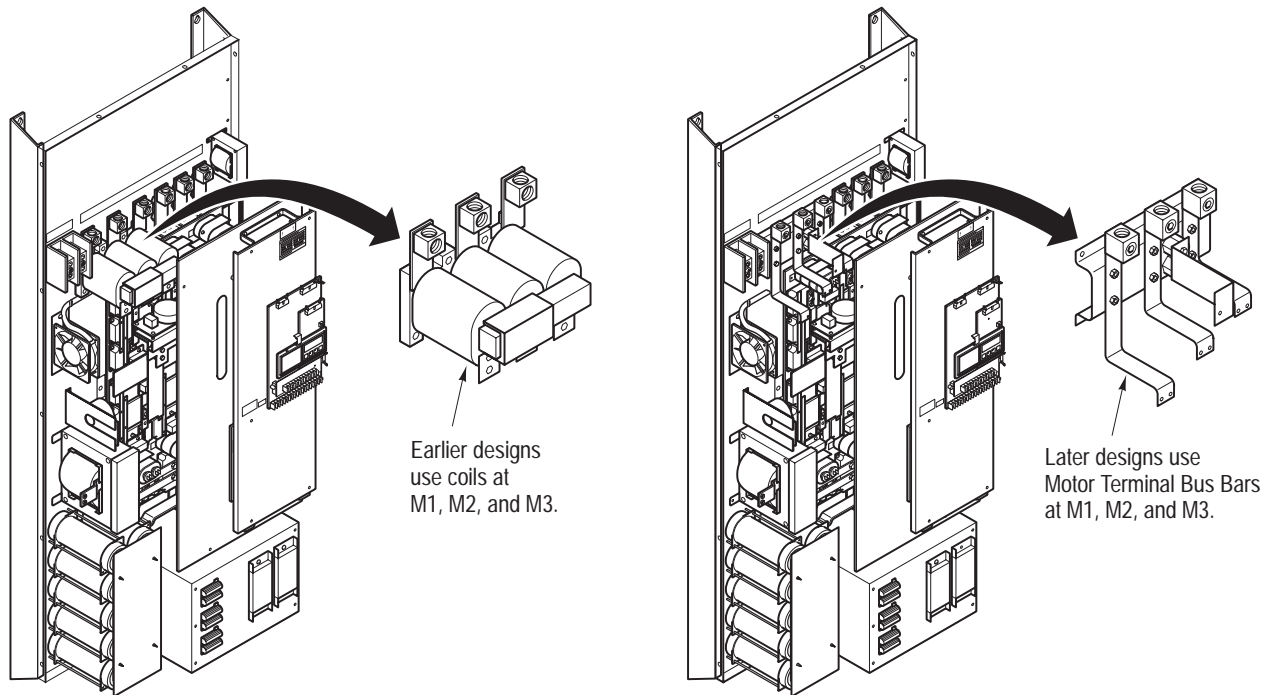

AB0150A



ATTENTION: Disconnect and lock out power from the drive before disassembling the drive. Failure to disconnect power may result in death or serious injury. A bus charge neon indicator provides visual indication that bus voltage is present. Verify bus voltage by measuring the voltage between +DC and -DC on Terminal Block TB1. Do not attempt to service the drive until the neon indicator has extinguished and the bus voltage has discharged to zero volts.



ATTENTION: This assembly contains parts and sub-assemblies that are sensitive to electrostatic discharge. Static control precautions are required when servicing this assembly. Component damage may result if you ignore electrostatic discharge control procedures. If you are not familiar with static control procedures, reference Allen-Bradley Publication 8000-4.5.2, Guarding Against Electrostatic Damage, or any other applicable ESD protection handbook.

Earlier designs of the Allen-Bradley 1336 and 1336VT Adjustable Frequency AC Drives have coils connected to Terminal Block TB1 terminals M1, M2, and M3. Later designs have Motor Terminal Bus Bars at M1, M2, and M3 (refer to the Load Reactor LR illustration). The illustrations in this manual show the earlier coil design. Connections from the Main Bus Bar assembly to the motor terminals are the same for either design.

Removal

IMPORTANT: Before you remove connections, bus bars, and wires from the drive components, mark the connections, bus bars, and wires to correspond with their component connections and terminals to guard against incorrect wiring during assembly.

1. Remove power from the drive.
2. Wait for Bus Indicator Light DS1 to turn off. Check for zero volts at TB1 Terminals +DC and –DC before proceeding.
3. Remove the Enclosure cover. Refer to Chapter – 2 Disassembly and Access Procedures, Removing the Drive Enclosure.
4. Remove the Main Control Mounting Plate. Refer to Chapter – 2 Disassembly and Access Procedures, Removing the Main Control Mounting Plate.
5. Remove the Base Driver Mounting Plate. Refer to Chapter – 2 Disassembly and Access Procedures, Removing the Base Driver Mounting Plate.
6. Loosen the socket-head screws fastening the motor wires to TB1 Terminals M1, M2, and M3.
7. Remove the screws fastening the bus wires to the Load Reactor coil terminals.

Installation

1. Remove the screws fastening the Load Reactor to the Main Chassis..
2. Remove the screws fastening the M1, M2, and M3 wire lugs to the Load Reactor.
3. Fasten the M1, M2, and M3 wire lugs to the replacement Load Reactor. Torque the screws to 108 lb-in. or 12 N-m.
4. Fasten the bus wires to the Load Reactor coil terminals. Torque the screws to 108 lb-in. or 12 N-m.
5. Insert the motor wires into Wire Lugs M1, M2, and M3. Torque the screws to 375 lb-in. or 42 N-m.
6. Install the Base Driver Mounting Plate, Main Control Mounting Plate, and Enclosure cover in reverse order of removal.



ATTENTION: Replace all guards before applying power to the drive. Failure to replace guards may result in death or serious injury.

This Page Intentionally Left Blank

Replacement Parts List

Chapter Objectives

This chapter illustrates and lists replacement parts for the 1336 Drives rated B150 – B200, C150 – C200, and 1336VT B200 – B250, and describes replacement parts ordering procedures.

Ordering Replacement Parts

For your convenience, the Allen-Bradley Motion Control Division and the Allen-Bradley Support Division provide efficient and convenient repair and exchange for eligible equipment.

A product service report number is required to return any equipment for repair. Your local Allen-Bradley distributor or area sales and support office can provide you with a product service report number.

You should return equipment to be repaired to the area sales and support center nearest you. Reference the product service report number on the carton and packing slip. Include:

- Your company name
- Your company address
- The repair purchase order number
- A brief description of the problem

Contact your local Allen-Bradley distributor or sales office for a complete listing of area sales and support centers near you.

Replacement Parts Listing

Figure 4.1
Replacement Parts for B150 – B200, C150 – C200, and 1336VT B200 – B250 Drives

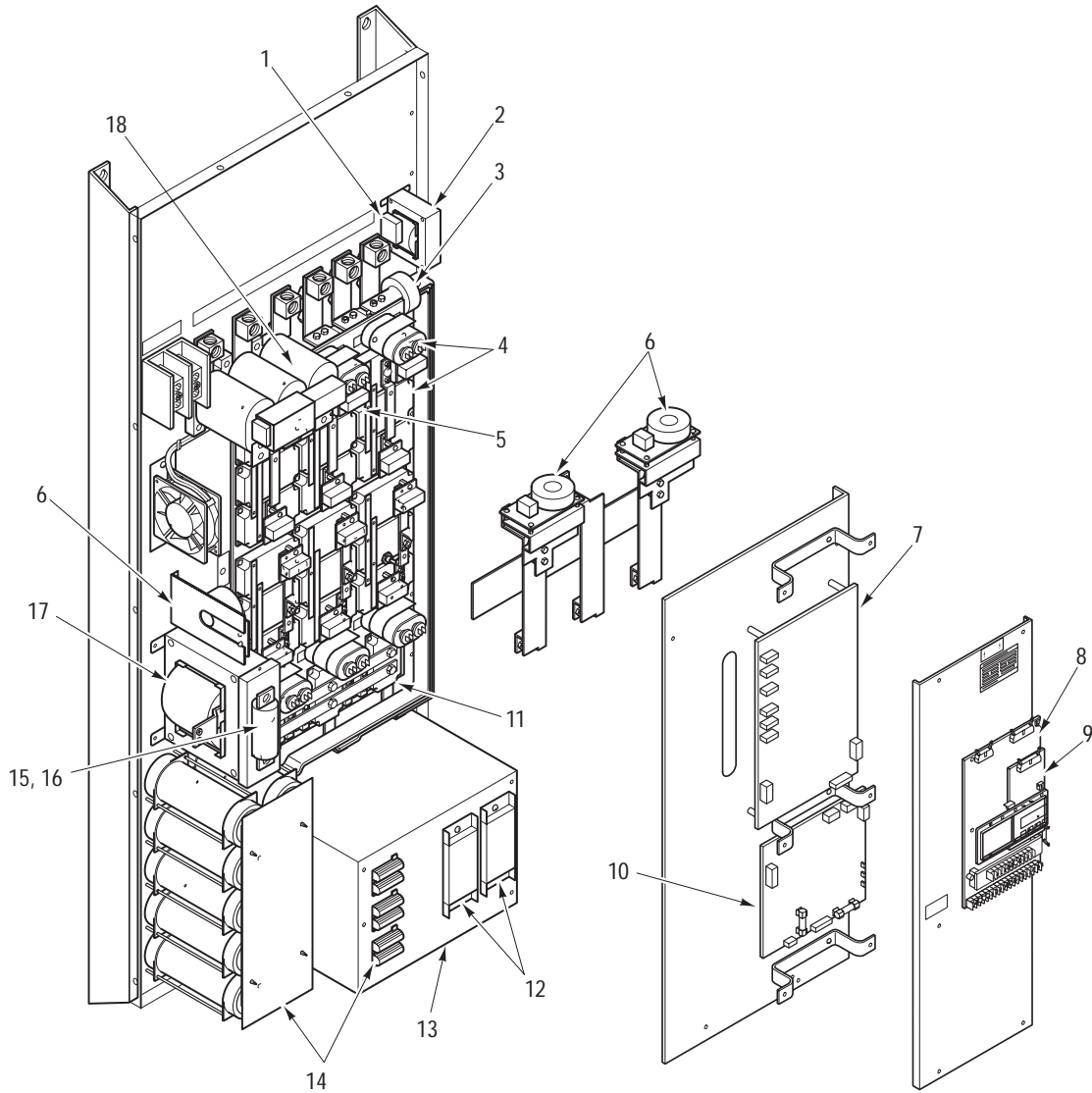

AB0155B

Table 4.A
Replacement Parts for 1336 B150 – B200, C150 – C200, and 1336VT B200 – B250 Drives

Callout	Symbol	Description	Location	Replacement Procedure
1	MOV1	Surge Suppressor	Main Chassis	Chapter 3, Surge Suppressor MOV1
2	T1	Transformer	Main Chassis	Chapter 3, Transformer T1
3	GND SENSE	Current Transducer	Main Chassis	Chapter 3, Ground Sense CT
4	X1 – 6, SN1 – 6	Transistor Modules and Snubbers	Heat Sink	Chapter 3, Transistor Modules and Snubbers
5	ST	Thermostat	Heat Sink	Chapter 3, Thermostat ST
6	BUS SENSE; LEM A, C	Current Transducer	Main Chassis	Chapter 3, Bus Sense Module; LEM A and LEM C
7	BASEDR/ PWRSPLY	Base Driver Board	—	Chapter 2, Removing the Base Driver/Power Supply Board
7	BASEDR/ PWRSPLY	Base Driver Board	—	Chapter 2, Removing the Base Driver/Power Supply Board
8	MAIN CTL	Main Control PCB	Main Control Board	Chapter 2, Removing the Main Control Board from the Mounting Plate
9	LOCAL DIS	Program and Display PCB	Program and Display Board	Chapter 2, Removing the Programming and Display Board
10	PRECHARGE	Precharge Board	Base/Driver Precharge Board	Chapter 2, Removing the Precharge Board
10	PRECHARGE	Precharge Board	Base/Driver Precharge Board	Chapter 2, Removing the Precharge Board
11	BR1, BR2, BR3	Bridge Rectifiers	Heat Sink	Chapter 3, SCR Modules
12	R7, R8	Precharge Resistor	Main Chassis	Chapter 3, Precharge Resistor
13	FAN	Fan	Main Chassis	Chapter 3, Fan
14	1C1 – 5, 2C1 – 5, 3C1 – 3	Bus Capacitors	Main Chassis	Chapter 3, Bus Capacitors
15	D1	Bus Diode	Main Chassis	Chapter 3, Bus Diode D1
16	F1	Bus Fuse	Main Chassis	Chapter 3, Bus Fuse F1
17	L1	DC Bus Inductor	Main Chassis	Chapter 3, DC Bus Inductor L1
18	LR	Load Reactor	Main Chassis	Chapter 3, Load Reactor LR
*	Ribbon Cables	—	—	Part numbers are located on the ribbon cables

This Page Intentionally Left Blank

150 – 200 HP 1336 Drives

Figure S.1 B150–B200 & C150–C200 Unit Schematic

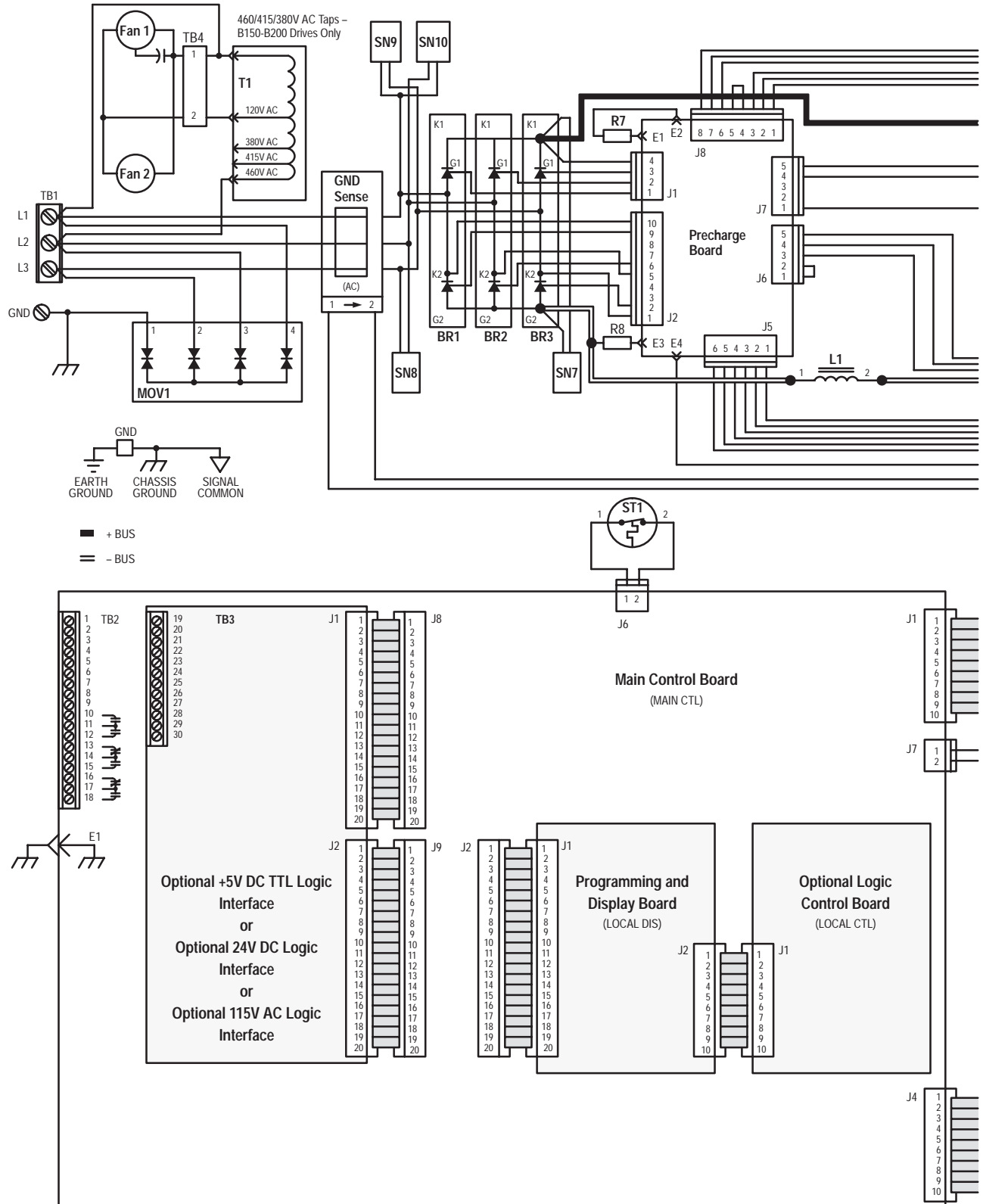

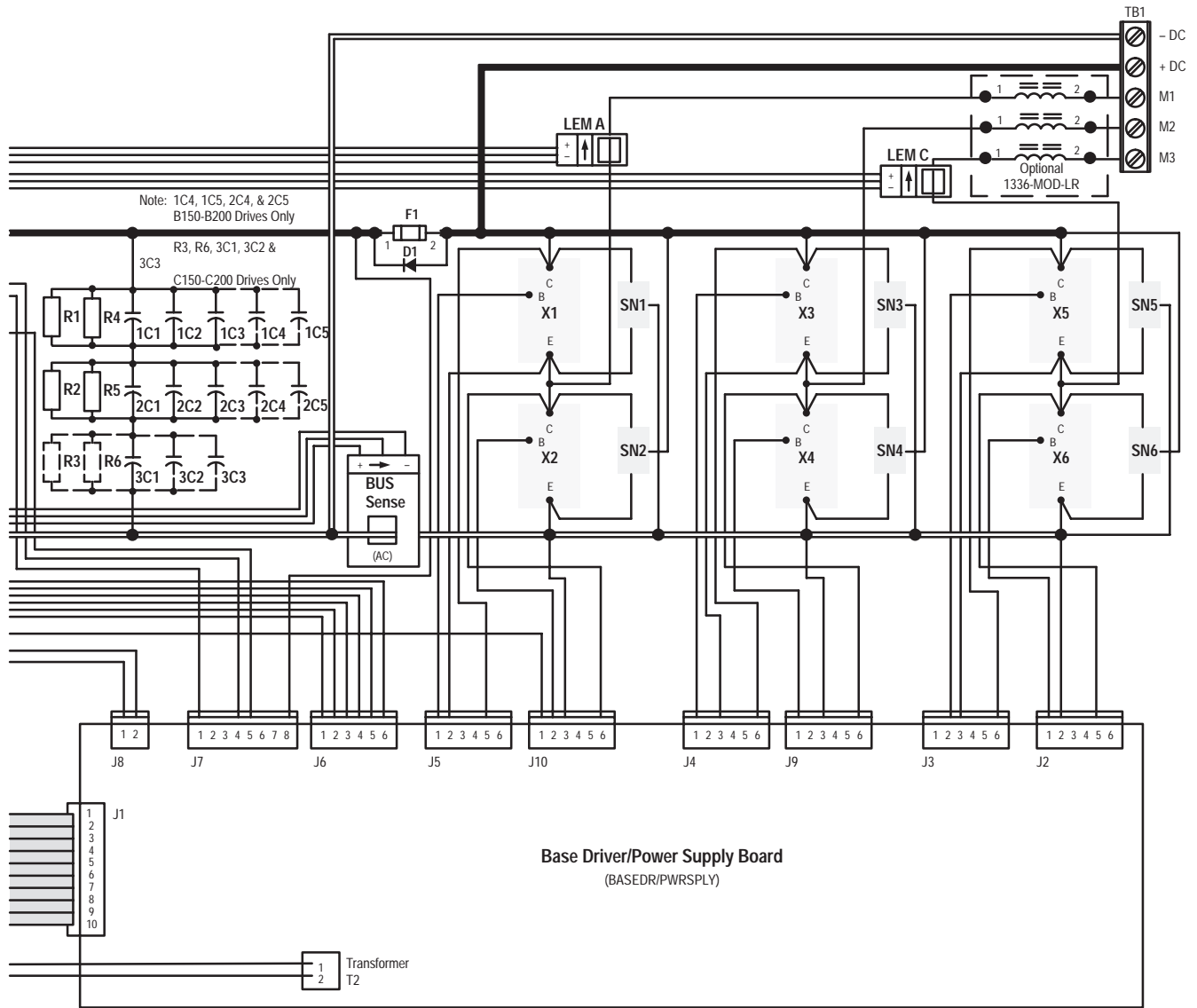

Snubber Diagrams

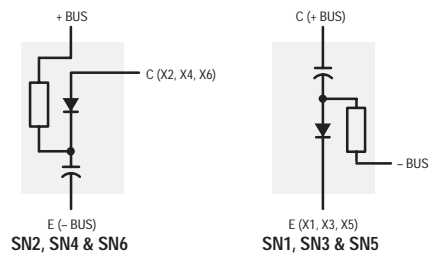

Output Transistor Diagram

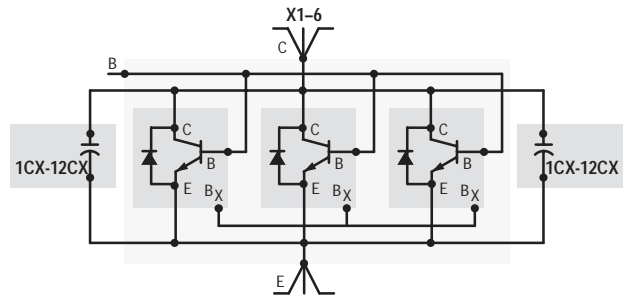

This Page Intentionally Left Blank

240 and 300 Amp 1336VT Drives

Figure S.2 – 1336VT 240 and 300 Amp Unit Schematic

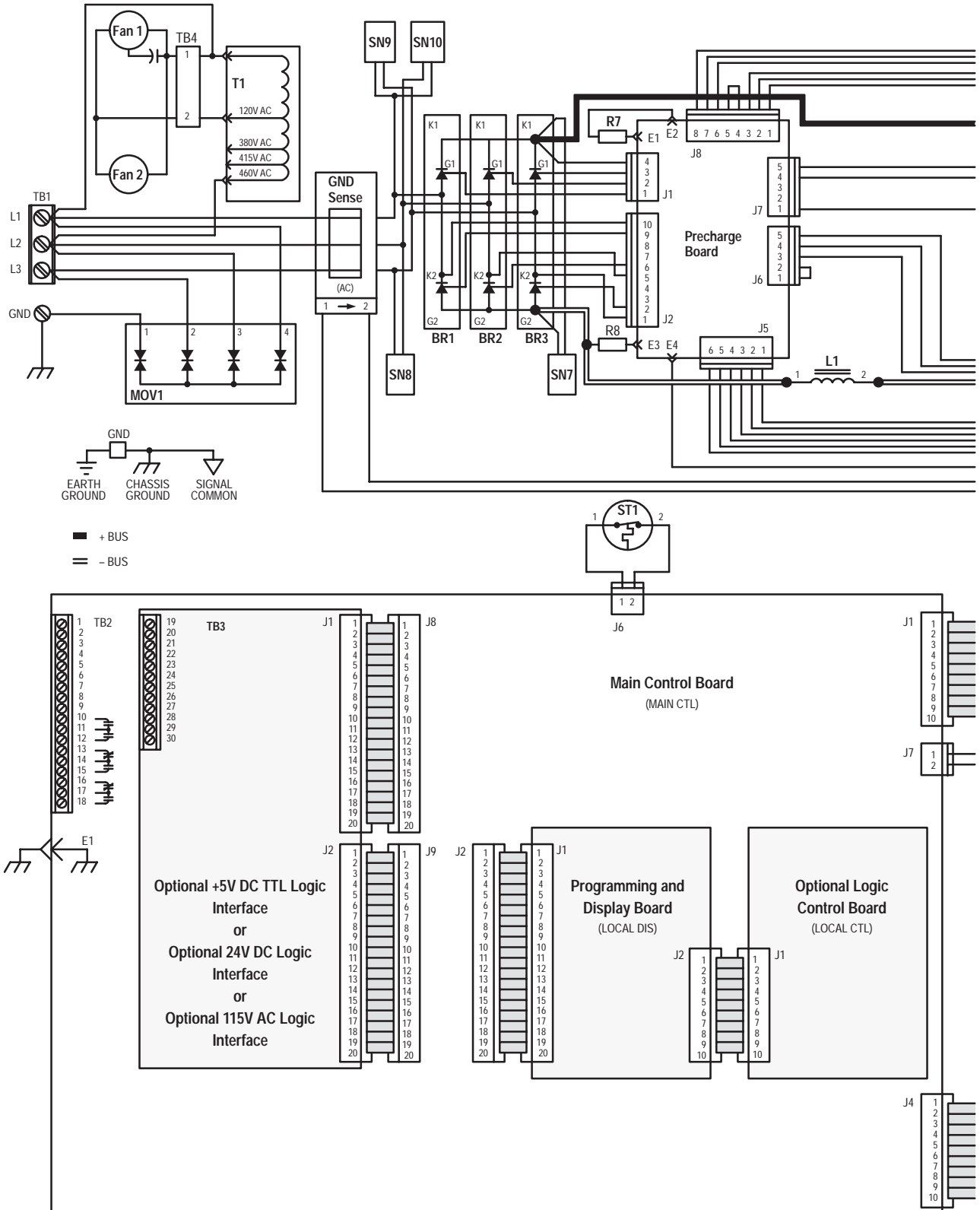

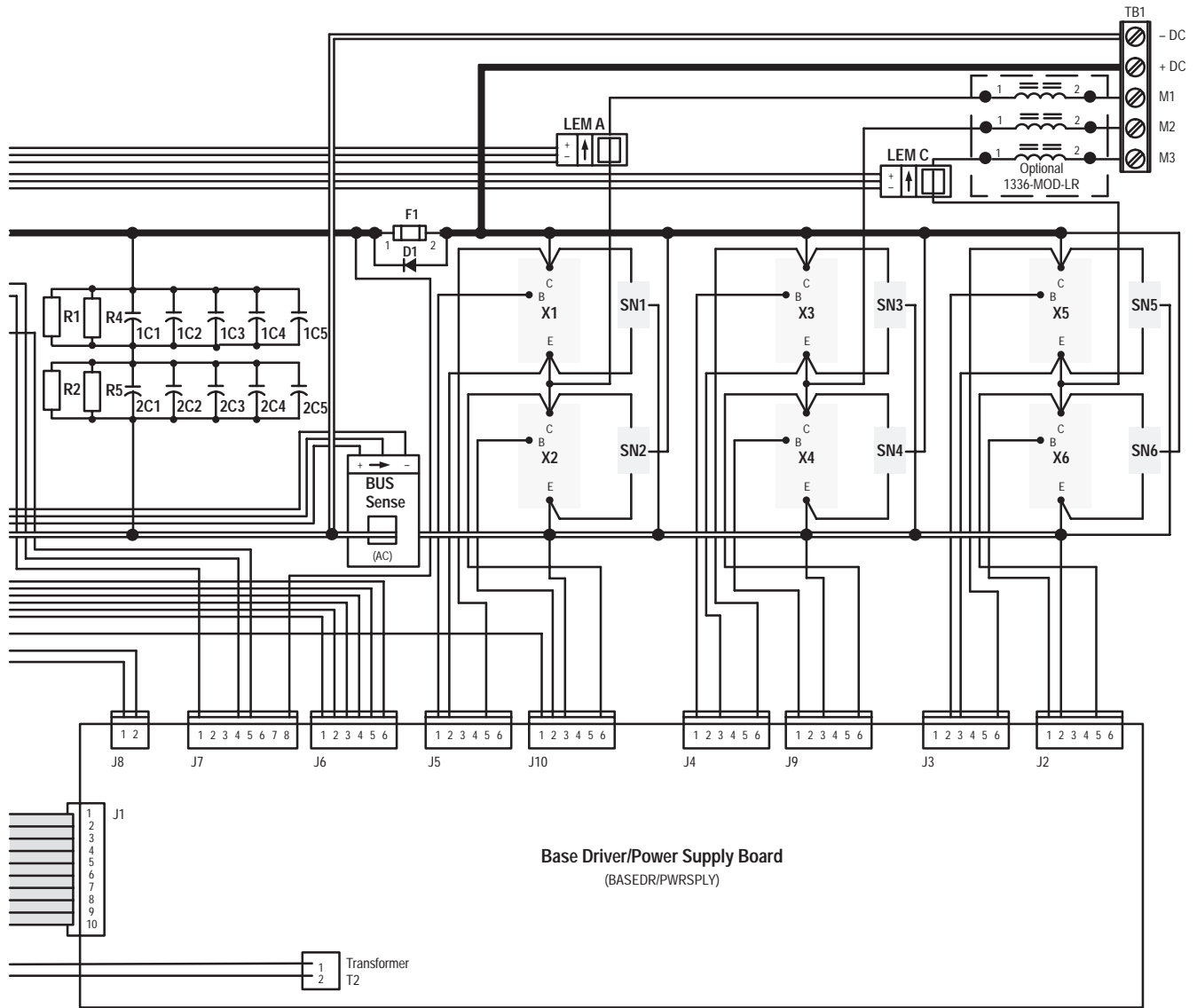

Snubber Diagrams

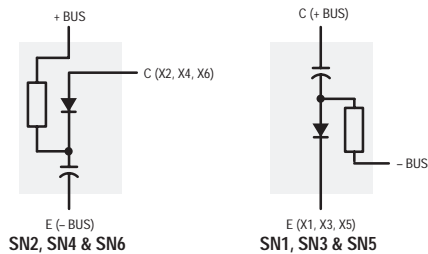

Output Transistor Diagram

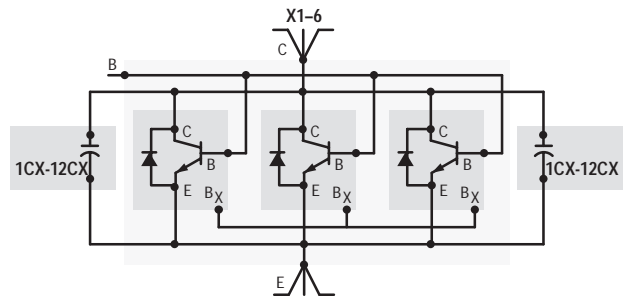

This Page Intentionally Left Blank

Glossary

+Bus: +Bus is the portion of the DC bus that is at positive (+) potential.

-Bus: -Bus is the portion of the DC bus that is at negative (-) potential.

AC Contactor: An alternating-current (AC) contactor establishes or interrupts an AC Power circuit.

Adjustable Speed: An adjustable speed motor maintains the desired operating speed (set speed) regardless of the load.

Adjustable Speed Drive (Electrical): The adjustable speed drive consists of the motor, drive controller, and (optional) local controls. The remote operator/drive controls may be either manual or automatic.

Ambient Temperature: Ambient temperature is the temperature of the air in which equipment is operated or stored.

Base Speed: Base speed is the manufacturer's nameplate rating at which the motor develops rated horsepower (hp) at rated load and voltage. With AC systems, base speed is commonly the point at which 60 Hz is applied to the induction motor.

BR: Refer to Bridge Rectifier.

Braking: Braking stops an AC motor. Braking may be accomplished in any of the following ways:

1. Dynamic braking (AC drives) continues to excite the motor from the drive, since AC motors do not have separate field excitation. This causes a regenerative current to the drive's intermediate bus to dissipate the power returned. The brake resistor is usually switched by a transistor or other power switch controlled by the drive.
2. Regenerative braking is similar to dynamic braking but is accomplished electronically. The generated power is returned to the line through the power converter. This power may also be dissipated as losses in the converter (within its limitations).
3. A motor-mounted or separately-mounted brake is a positive-action, mechanical friction device. When power is removed, the brake is activated.

Breakaway Torque: Breakaway torque is the torque required to start a machine from standstill. Breakaway torque is always greater than the torque needed to maintain motion.

Breakdown Torque: The breakdown torque of an AC motor is the maximum torque developed with rated voltage applied at rated frequency.

Bridge Rectifier (Diode, SCR): A diode bridge rectifier is a non-controlled, full-wave rectifier that produces a constant, rectified, DC voltage. An SCR bridge rectifier is a full-wave rectifier with a DC output that can be controlled by switching on the gate control element.

Bridge Rectifier: A bridge rectifier is a full-wave rectifier that conducts current (through the load) in only one direction with respect to the alternating input voltage. AC applied to the input results in approximate DC at the output.

British Thermal Unit (BTU): A BTU is the quantity of heat required to raise one pound of water by one degree Fahrenheit.

BTU: Refer to British Thermal Unit.

Bus Sense: Bus Sense is a signal transducer that generates a signal proportional to the current in the drive's DC bus. The control logic uses this signal to sense the presence or absence of bus voltage.

CEMF: Refer to Counter Electromotive Force.

CMOS: Refer to Complimentary Metallic Oxide Semiconductor.

Cogging: Cogging is a condition in which a motor does not rotate smoothly but steps or jerks from one position to another during shaft rotation. Cogging is most pronounced at low motor speeds and can cause objectionable vibrations in the driven machinery.

Complimentary Metallic Oxide Semiconductor (CMOS): A CMOS is an integrated-circuit component for logic circuits. CMOS components use very low power and have high switching rates. The CMOS is sensitive to high-voltage static discharges. Follow proper electrostatic discharge precautions to avoid damage to these components.

Constant Torque Range: Constant torque range is a speed range within which a motor is capable of delivering a constant torque, subject to cooling limitations of the motor.

Constant Voltage Range: Constant voltage range applies to AC drives. This is the range of motor operation within which the drive's output voltage is held constant as output frequency is varied. This range produces motor performance similar to a DC drive's constant horsepower (hp) range.

Constant Volts per Hertz (V/Hz): The V/Hz relationship exists in AC drives where the output voltage is directly proportional to frequency. This type of operation produces constant rated torque as the motor's speed varies.

Continuous Duty: Continuous duty (CONT) refers to a motor that can continue to operate within insulation temperature limits after it has reached normal operating (equilibrium) temperature.

Converter: A converter changes AC to DC, often through a diode rectifier or thyristor rectifier circuit. Converter also refers to the process of changing AC to DC to AC (e.g., adjustable frequency drive). A frequency converter, such as that found in an adjustable frequency drive, consists of a rectifier, a DC intermediate circuit, an inverter, and a control unit.

Counter Electromotive Force (CEMF): CEMF is the energy per unit of charge converted into electrical form by a generator or a motor acting as a generator. This energy is in opposition to, or counters, the applied voltage.

Current Limiting: Current limiting is an electronic process of limiting the maximum current available to the motor. This is adjustable so that the motor's maximum current can be limited. Current limiting can be preset to protect both the motor and the control from extended overloads.

DC Boost: DC boost compensates for the voltage drop across the resistance of an AC motor circuit and the resulting reduction in torque.

DC Bus: DC bus is a drive's power structure that transmits a rectified AC line power from the bridge rectifier to the output transistors.

Diode: A diode passes current in one direction but blocks current flow in the reverse direction.

Drift: Drift is the deviation from the initial set speed with no load change over a specific time. Normally, the drive must be operated for a specific warm-up time at a specified ambient temperature before drift specifications apply. Drift is normally caused by random changes in operating characteristics of various control components.

Drive Controller: A drive controller, sometimes called a variable speed drive, controls the speed, torque, horsepower, and direction of an AC or DC motor.

Duty Cycle: A time interval occupied by starting, running, stopping and idling.

Dynamic Braking: Refer to Braking.

Efficiency: Efficiency is the ratio of useful output to input, expressed in percentage. In motors, efficiency is the effectiveness with which a motor converts electrical energy into mechanical energy.

Electrostatic Discharge (ESD): ESD is a static-electricity discharge that may damage drive components. Refer to the ESD precautions found in this manual to guard against damage to drive components.

Enable: To enable is to allow an action or acceptance of data by applying an appropriate signal to the appropriate input. Switch SW1, located on the Programming and Display Board, allows you to enable and disable the programming functions of a drive.

Enclosure: An enclosure is the housing in which a motor control is mounted. Enclosures are available for most environmental conditions.

ESD: Refer to Electrostatic Discharge.

Floating Ground: Floating ground describes a circuit in which the electrical common point is not at earth ground potential or the same ground potential as the circuitry with which the floating ground circuit is associated. Voltage differences can exist between the floating ground and earth ground.

Force: Force is the tendency to change the motion of an object with an exertion of energy from a separate source. Force is measured in pound-feet, ounce-inches, Newton-meters, or gram-centimeters.

Full Load Torque: The full-load torque of a motor is the torque necessary to produce rated horsepower at full-load speed.

Gate: A gate is the control element of the SCR (silicon-controlled rectifier), commonly referred to as a thyristor. When a small positive voltage is applied momentarily to the gate, the SCR conducts current. Current conduction continues after the gate signal is removed.

GND Sense: GND sense, or ground sense, is a current transducer that detects an unequal or imbalanced current in the three-phase AC line or DC bus of the drive. The imbalance indicates an output ground fault condition.

Horsepower (hp): Horsepower is a measure of the amount of work a motor can perform in a given length of time. Refer to “Power” for kilowatt equivalent.

Induction Motor: An induction motor is an alternating-current motor in which the primary winding on one member is connected to the power source. A secondary winding on the other member carries the induced current. There is no physical electrical connection to the secondary winding; its current is induced.

IEC: Just as the National Electrical Manufacturers Association goes by its acronym, “NEMA,” the International Electrotechnical Commission goes by “IEC.” And, like NEMA, IEC establishes and publishes mechanical and electrical standards.

Inertia: Inertia is a measure of a body’s resistance to change in velocity, whether a body is at rest or moving at a constant velocity. The velocity can be either linear or rotational. The moment of inertia (WK^2) is the product of the object’s weight (W) and the square of the radius of gyration (K^2). The radius of gyration is a measure of how the mass of the object is distributed on the axis of rotation. The moment of inertia is expressed in $lb-ft^2$ or Newton-meters².

Integral-Horsepower Motor: An integral-horsepower motor is any motor built in a frame having a continuous rating of 1 horsepower (hp) or more.

Interposing Relay: An interposing relay is a relay that accepts control signals of one logic level in order to provide isolated contact signals in a circuit operating at a different logic level.

Inverter: An inverter is an adjustable frequency AC drive or a particular section of an AC drive. The inverter section uses the DC voltage from a previous circuit stage (intermediate DC circuit) to produce an AC current or voltage of a desired frequency.

ISO: The International Standards Organization (ISO) based in Geneva, Switzerland, has developed a series of global standards to define and “harmonize” product, service and business practices worldwide. The ISO 9000 series, in particular, describes basic quality systems such as personnel training guidelines and quality documentation procedures.

Isolation Transformer: An Isolation Transformer electrically separates the drive from the AC power supply line. An isolation transformer:

1. Helps protect semiconductors from line voltage transients.
2. Reduces disturbances from other solid-state control equipment such as drives without isolation transformers, time clock systems, electronic counters, etc.

Jogging: Jogging is the momentary movement of a motor, usually through momentary closure of a circuit using a single pushbutton or contact element.

Kinetic Energy: Kinetic energy is an object's energy of motion.

LAD: Refer to Linear Acceleration/Deceleration.

LEM: LEM is a hall-effect current transducer that senses drive output current and generates a signal for the control logic.

Linear Acceleration/Deceleration (LAD): LAD is a circuit that controls the rate at which a motor accelerates to a set speed or decelerates to zero speed. On most motor drives, this circuit can be adjusted and set to accommodate particular applications.

Linearity: Linearity is a measure of how closely a characteristic follows a straight-line function.

Locked-Rotor Current: Locked-rotor current is a steady current taken from the power supply line current with the rotor at standstill, at rated voltage and frequency. This current is present when starting the motor and when the motor is under load.

Locked-Rotor Torque: Locked-rotor torque is the minimum torque a motor develops at rest for all angular positions of the rotor, with rated voltage applied at rated frequency.

Megger Test: A Meggar test measures an insulation system's resistance. This test passes a low current, high voltage through a motor's windings and measures the resistance of the various insulation systems. Meggar test results are usually expressed in megohms. Must be done with motor disconnected from drive.

MOV: Refer to Surge Protection.

National Electrical Code (NEC): NEC is the code recommendations of the National Fire Protection Association. These codes are revised every three years. City or state code regulations take precedence over, and may differ from, NEC code regulations.

National Electrical Manufacturer's Association (NEMA): NEMA is a non-profit organization organized and supported by electrical equipment and supply manufacturers. Some NEMA motor standards include horsepower (hp) ratings, speeds, frame sizes and dimensions, torques, and drive enclosures.

NEC: Refer to National Electrical Code.

NEMA: Refer to National Electrical Manufacturer's Association.

Offset: Offset is the steady-state deviation of a controlled variable from a fixed setpoint.

Op Amp: Refer to Operational Amplifier.

Open Loop: An open loop is a control system lacking feedback.

Operational Amplifier: An operational amplifier is usually a high-gain DC amplifier designed to be used with external circuit elements.

Overload Capacity: Overload capacity describes the ability of a drive to withstand currents beyond the system's continuous rating. Overload capacity is usually expressed as a percentage of full-load current endured in a specified time.

PC: Refer to Programmable Controller.

Plugging: Plugging is a method of motor braking that reverses either the line voltage polarity or the phase sequence. Plugging applies counter-torque to a motor, exerting a retarding, or braking, force.

Pot: A pot is a potentiometer, or variable resistor.

Power Factor (Displacement): Displacement power factor is a measurement of the time phase difference between the fundamental voltage and fundamental current in an AC circuit. It represents the cosine of the phase angle difference. $F_p = \cos(\alpha - \beta)$

Power Factor (Distortion): Distortion power factor is a measurement of the ratio of the real power (kW) to the apparent power (kVA). Distortion power factor takes into account harmonic voltage and current distortion as well as voltage-to-current displacement.

Power: Power is work accomplished per unit of time. Power is measured and expressed in horsepower (horsepower (hp)) or watts (W): 1 horsepower (hp) = 33,000 ft-lb/min. = 746 W or 24,340 N-m/min = 1 kW.

Preform: Preform is a flexible material used between an electronic component and the heat sink to which the component is attached. Preform provides maximum heat dissipation from the component to the heat sink.

Preset Speed: Preset speed describes one or more fixed speeds at which a drive operates.

Programmable Controller: A programmable controller provides control logic for machines and processes. A sequence of operations can be changed easily through software programming.

Pull-In Torque: Pull-in torque is the maximum constant torque to which a synchronous motor accelerates into synchronism at rated voltage and frequency.

Pull-Out Torque: Pull-out torque is the maximum running torque of a synchronous motor.

Pull-Up Torque: Pull-up torque is the torque required to accelerate a load from standstill to full speed. Breakdown torque occurs at full speed. Pull-up torque is expressed in percentage of running torque. This torque overcomes friction, windage, product loading, and inertial forces.

Pulse Width Modulating (PWM): PWM is an AC adjustable frequency drive that accomplishes frequency and output control at the output (inverter) section of the drive. The drive's voltage is always a constant amplitude, the average voltage of which is controlled through pulse width modulating.

PWM: Refer to Pulse Width Modulating.

Reactance: Reactance is the opposition (resistance) of a circuit or component to an alternating current. Reactance is measured and expressed in ohms.

Rectifier: A rectifier is an electrical device that transforms alternating current (AC) to direct current (DC).

Regeneration: Regeneration is the characteristic of a motor to act as a generator when a rotor synchronous frequency is greater than the applied frequency (AC drives).

Regenerative Braking: Regenerative Braking slows or stops a motor through regeneration. Refer to Regeneration and Braking.

Resolution: Resolution is the smallest distinguishable increment into which a quantity can be divided. This increment may be shaft speed or shaft position by degrees. Resolution is also the degree to which nearly-equal values of a quantity can be discriminated.

SCR: Refer to Silicon Controlled Rectifier.

Service Factor: A service factor is a number appearing on a motor nameplate. This number indicates the extent to which a motor may be overloaded above the nameplate rating without causing serious degradation. A motor with a 1.15 service factor can produce 15 percent greater torque than a motor with a 1.0 service factor. A service factor may also apply to motors and gearmotors as a figure of merit used to adjust measured loads in an attempt to compensate for conditions which are difficult to measure or define.

Set Speed: The set speed is the desired operating speed of a motor.

Shock Load: Shock loads affect clutches, brakes, and motors in systems that transmit high-peak loads. Shock loads are present in crushers, separators, grinders, conveyors, winches, and cranes.

Silicon Controlled Rectifier (SCR): The SCR is a solid-state switch sometimes referred to as a thyristor. The SCR has an anode, a cathode, and a control element called a gate. Because it can be turned on at will, the SCR provides controlled rectification. The SCR is small, lightweight, and can rapidly switch large currents at high voltages.

Slip: Slip is the difference between the rotating magnetic field speed (synchronous speed) and the rotor speed of an AC induction motor. Slip is usually expressed as a percentage of synchronous speed.

Speed Range: Speed range is the range of minimum and maximum speed within which a motor must operate under constant or variable torque conditions. A 50:1 speed range for a motor with a maximum speed of 1800 rpm means the motor must operate at a minimum speed of 36 rpm and remain within regulation specifications. Controllers are capable of wider controllable speed ranges than motors because there is no thermal limitation, only electrical.

Speed Regulation: Speed regulation is a measurement of how accurately a motor speed is maintained. Speed regulation is measured and expressed in percentage of change between full-load and no-load speeds.

Surge Protection: Surge protection is the process of absorbing and clipping voltage transients on an incoming AC power line or control circuit. Surge protectors include MOVs (Metal Oxide Varistors) and specially designed R-C networks.

Synchronous Speed: Synchronous speed is the speed of the rotating magnetic field on an AC induction motor. The frequency applied to the stator and the number of magnetic poles present in each phase of the stator windings determines synchronous speed. Synchronous speed is mathematically expressed as: $\text{sync speed (rpm)} = 120 \times \text{applied freq. (Hz)} / \text{number of poles per phase}$.

Torque: Torque is a turning force applied to a shaft. This force tends to cause shaft rotation. Torque is normally measured and expressed in ounce-inches (oz-in.) and pound-feet (lb-ft). Torque is the product of the force applied to an object and the radius through which that force acts upon the object.

Transducer: A transducer converts one energy form to another, such as mechanical energy to electrical energy. A transducer is also a device that, when actuated by signals from one or more systems or media, supplies related signals to one or more other systems or media.

Transient: A transient is a momentary power deviation in an electrical or mechanical system.

Transistor: A transistor is a solid-state component. The terminals are called the emitter, the base, and the collector. Transistors amplify, switch, and control signals.

Work: Work is a force needed to move an object or load over a distance. Work is measured in inch-ounces (in.-oz), gram-centimeters (gm-cm), foot-pounds (ft-lbs), or Newton-meters (N-m). $\text{Work} = \text{force} \times \text{distance}$.

This Page Intentionally Left Blank



We Want Our Manuals to be the Best!

You can help! Our manuals must meet the needs of you, the user. This is your opportunity to make sure they do just that. By filling out this form you can help us provide the most useful, thorough, and accurate manuals available. Please take a few minutes to tell us what you think. Then mail this form, FAX it, or send comments via E-Mail.

FAX: to your local Allen-Bradley Sales Office or 414/242-8579

E-Mail: via Internet to "sepatter@msmacab.remnet.ab.com"

PUBLICATION NAME _____

PUBLICATION NUMBER, DATE AND PART NUMBER (IF PRESENT) _____

✓ CHECK THE FUNCTION THAT MOST CLEARLY DESCRIBES YOUR JOB.

- SUGGEST / RESPONSIBLE FOR THE PURCHASE OF EQUIPMENT
- MAINTAIN / OPERATE PROGRAMMABLE MACHINERY
- DESIGN / IMPLEMENT ELECTRICAL SYSTEMS
- TRAIN/EDUCATE MACHINE USERS
- SUPERVISE FLOOR OPERATIONS

✓ WHAT LEVEL OF EXPERIENCE DO YOU HAVE WITH EACH OF THE FOLLOWING PRODUCTS?

	NONE	LITTLE	MODERATE	EXTENSIVE
PROGRAMMABLE CONTROL	<input type="checkbox"/>	<input type="checkbox"/>	<input type="checkbox"/>	<input type="checkbox"/>
AC / DC DRIVES	<input type="checkbox"/>	<input type="checkbox"/>	<input type="checkbox"/>	<input type="checkbox"/>
PERSONAL COMPUTERS	<input type="checkbox"/>	<input type="checkbox"/>	<input type="checkbox"/>	<input type="checkbox"/>
NC / CNC CONTROLS	<input type="checkbox"/>	<input type="checkbox"/>	<input type="checkbox"/>	<input type="checkbox"/>
DATA COMMUNICATIONS / LAN	<input type="checkbox"/>	<input type="checkbox"/>	<input type="checkbox"/>	<input type="checkbox"/>

✓ RATE THE OVERALL QUALITY OF THIS MANUAL BY CIRCLING YOUR RESPONSE BELOW. (1) = POOR (5) = EXCELLENT

HELPFULNESS OF INDEX / TABLE OF CONTENTS		1	2	3	4	5
CLARITY		1	2	3	4	5
EASE OF USE		1	2	3	4	5
ACCURACY AND COMPLETENESS		1	2	3	4	5
QUALITY COMPARED TO OTHER COMPANIES' MANUALS		1	2	3	4	5
QUALITY COMPARED TO OTHER ALLEN-BRADLEY MANUALS		1	2	3	4	5

✓ WHAT DID YOU LIKE MOST ABOUT THIS MANUAL?

✓ WHAT DID YOU LIKE LEAST ABOUT THIS MANUAL?

✓ PLEASE LIST ANY ERRORS YOU FOUND IN THIS MANUAL (REFERENCE PAGE, TABLE, OR FIGURE NUMBERS).

✓ DO YOU HAVE ANY ADDITIONAL COMMENTS?

✓ COMPLETE THE FOLLOWING.

NAME _____ COMPANY _____

TITLE _____ DEPARTMENT _____

STREET _____ CITY _____ STATE _____ ZIP _____

TELEPHONE _____ DATE _____

CUT ALONG DOTTED LINE

FOLD HERE

FOLD HERE



BUSINESS REPLY MAIL

FIRST CLASS PERMIT NO. 413 MEQUON, WI

POSTAGE WILL BE PAID BY ADDRESSEE

ALLEN-BRADLEY
Attn: Marketing Communications
P.O. Box 760
Mequon, WI 53092-9907

NO POSTAGE
NECESSARY
IF MAILED
IN THE
UNITED STATES

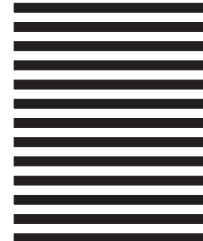

SCANport is a trademark of Allen-Bradley Company, Inc.
PLC is a registered trademark of Allen-Bradley Company, Inc.



Allen-Bradley, a Rockwell Automation Business, has been helping its customers improve productivity and quality for more than 90 years. We design, manufacture and support a broad range of automation products worldwide. They include logic processors, power and motion control devices, operator interfaces, sensors and a variety of software. Rockwell is one of the world's leading technology companies.



Worldwide representation.

Argentina • Australia • Austria • Bahrain • Belgium • Brazil • Bulgaria • Canada • Chile • China, PRC • Colombia • Costa Rica • Croatia • Cyprus • Czech Republic • Denmark • Ecuador • Egypt • El Salvador • Finland • France • Germany • Greece • Guatemala • Honduras • Hong Kong • Hungary • Iceland • India • Indonesia • Ireland • Israel • Italy • Jamaica • Japan • Jordan • Korea • Kuwait • Lebanon • Malaysia • Mexico • Netherlands • New Zealand • Norway • Pakistan • Peru • Philippines • Poland • Portugal • Puerto Rico • Qatar • Romania • Russia-CIS • Saudi Arabia • Singapore • Slovakia • Slovenia • South Africa, Republic • Spain • Sweden • Switzerland • Taiwan • Thailand • Turkey • United Arab Emirates • United Kingdom • United States • Uruguay • Venezuela • Yugoslavia

Allen-Bradley Headquarters, 1201 South Second Street, Milwaukee, WI 53204 USA, Tel: (1) 414 382-2000 Fax: (1) 414 382-4444