

MagneMover™ LITE 250 mm Railless Motor

Catalog Numbers 700-1308-22, 700-1308-25, MMI-MML-250M-NR-SER-SYNCAC, 700-1708-22, 700-1708-25, 700-1708-25-AC

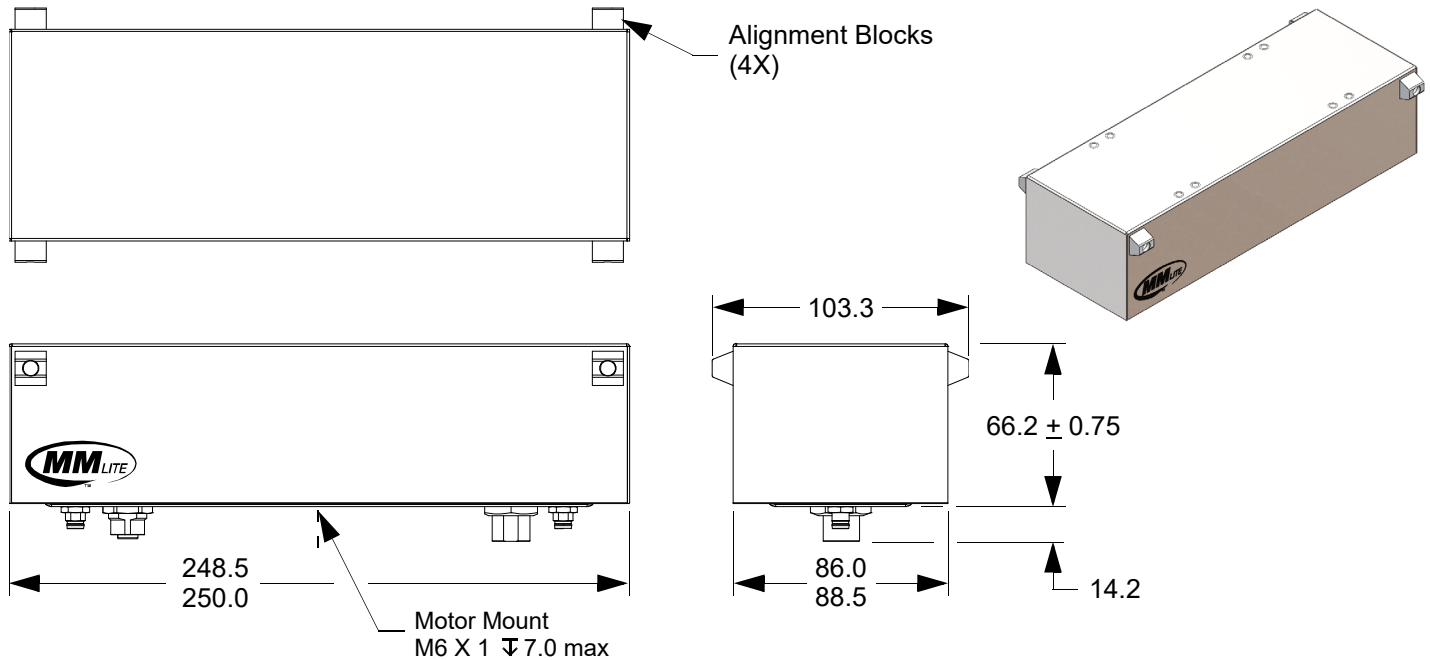

- MagneMover LITE railless systems consist of modules that include motors, vehicles (pucks) with integral magnet arrays, switches, controllers, and power supplies.
- MagneMover LITE motors contain integral motor controllers and position sensing.
- Railless motors are compatible with the MagneMotion Precision Rail guidance and vehicle system. Alternately, customers can design their own guidance and vehicle system.
- Magnet arrays used with motors are approximately 62 mm by 62 mm.
- Up to nine vehicles in motion per meter depending upon vehicle size.
- Up to ten vehicles in queue per meter standard, up to twelve vehicles in queue per meter depending upon application.
- Location repeatability to ± 0.5 mm, station repeatability to ± 0.1 mm with calibration.
- Wash-down capable (designed for IEC 60529, IP65).
- CE Certified, UL Recognized.

Physical Specifications

Dimensions*: 103.3 W x 250.0 L x 66.2 H

Weight: 1.9 kg [4.2 lb]

* All dimensions are in millimeters. Contact MagneMotion for detailed drawings.

Environmental Specifications

Ambient Temperature: 0° C to 50° C [32° F to 122° F]

Relative Humidity: 85% max (relative, non-condensing)

Electrical Specifications

Drive Rating: 36 VDC $\pm 10\%$, 0.4 A typical, 1.2 A max.

Power: 5 W drawn by the motor alone.
Maximum additional power drawn by the motor is 15 W per magnet array when the vehicle is moving at maximum acceleration or velocity.

Performance Specifications†

Recommended Max Acceleration: 2 m/s² [0.2 g]

Recommended Max Velocity: 2.0 m/s [4.5 mph]

Repeatability: ± 0.50 mm nominal
(at recommended max payload) ± 0.10 mm with calibration

Recommended Max Payload: 2.5 kg+ per vehicle‡

† Operating performance will vary based on payloads, acceleration and velocity settings, and vehicle density (refer to tables).

‡ Single array vehicle recommended maximum payload is 2.5 kg, dual array vehicle recommended maximum payload is 5.0 kg.

Rockwell Automation Support

Use the following resources to access support information.

Technical Support Center	Knowledgebase Articles, How-to Videos, FAQs, Chat, User Forums, and Product Notification Updates.	https://rockwellautomation.custhelp.com/
Local Technical Support Phone Numbers	Locate the phone number for your country.	http://www.rockwellautomation.com/global/support/get-support-now.page
Direct Dial Codes	Find the Direct Dial Code for your product. Use the code to route your call directly to a technical support engineer.	http://www.rockwellautomation.com/global/support/direct-dial.page
Literature Library	Installation Instructions, Manuals, Brochures, and Technical Data.	http://www.rockwellautomation.com/global/literature-library/overview.page
Product Compatibility and Download Center (PCDC)	Get help determining how products interact, check features and capabilities, and find associated firmware.	http://www.rockwellautomation.com/global/support/pcdc.page

Documentation Feedback

Your comments will help us serve your documentation needs better. If you have any suggestions on how to improve this document, complete the How Are We Doing? form at http://literature.rockwellautomation.com/idc/groups/literature/documents/du/ra-du002_-en-e.pdf.

Rockwell Automation maintains current product environmental information on its website at <http://www.rockwellautomation.com/rockwellautomation/about-us/sustainability-ethics/product-environmental-compliance.page>.

Product certificates are located in the Rockwell Automation Literature Library: <http://www.rockwellautomation.com/global/literature-library/overview.page>

Allen-Bradley, Rockwell Software, and Rockwell Automation are trademarks of Rockwell Automation, Inc.

Trademarks not belonging to Rockwell Automation are property of their respective companies.

Rockwell Otomasyon Ticaret A.Ş., Kar Plaza İş Merkezi E Blok Kat:6 34752 İçerenköy, İstanbul, Tel: +90 (216) 5698400

www.rockwellautomation.com

Power, Control and Information Solutions Headquarters

Americas: Rockwell Automation, 1201 South Second Street, Milwaukee, WI 53204-2496 USA, Tel: (1) 414.382.2000, Fax: (1) 414.382.4444

Europe/Middle East/Africa: Rockwell Automation NV, Pegasus Park, De Kleetlaan 12a, 1831 Diegem, Belgium, Tel: (32) 2 663 0600, Fax: (32) 2 663 0640

Asia Pacific: Rockwell Automation, Level 14, Core F, Cyberport 3, 100 Cyberport Road, Hong Kong, Tel: (852) 2887 4788, Fax: (852) 2508 1846

Copyright © 2015–2020 MagneMotion, A Rockwell Automation Company. All Rights Reserved.

139 Barnum Road, Devens, MA 01434, USA

+1 978-757-9100

Publication MMI-TD028B-EN-P - March 2020

Supersedes 990000683 Rev. A

DIR 990000683

www.rockwellautomation.com