

PowerFlex 700L Liquid-cooled AC Drives

Catalog Number 20L

Topic	Page
Summary of Changes	2
Product Overview	3
Key Features/Benefits	3
Communication and Human Interface Options	4
Catalog Number Explanation	6
Standard Drive Product Selection	8
Factory Installed Options	9
User Installed Options	10
Product Dimensions	12
Installation Considerations	14
Cable Recommendations	20
Fuse and Circuit Breaker Ratings	21
Maximum Motor Cable Lengths	23
DPI Connections	23
Control Connections	27
Control Highlights	30
Standard Drive Specifications	35
Derating Guidelines	39
Watts Loss	40
Cooling Loop Options	40
Additional Resources	47



Summary of Changes

This publication contains the following new or updated information. This list includes substantive updates only and is not intended to reflect all changes.

Topic	Page
Added note stating that Frame 2 ratings are no longer available for sale.	6
Removed these two option kits, which are no longer available for sale, from the Communication Option Kits table: External DPI I/O Option Board and Compact I/O Module (3 Channel).	11
Removed the Resolver option kit, which is no longer available for sale, from the Feedback Option Kits table.	11

Rockwell Automation recognizes that some of the terms that are currently used in our industry and in this presentation are not in alignment with the movement toward inclusive language in technology. We are proactively collaborating with industry peers to find alternatives to such terms and making changes to our products and content. Please excuse the use of such terms in our content while we implement these changes.

Product Overview

PowerFlex® 700L Liquid-cooled AC drives are responsive, high performance, regenerative industrial drives for installations requiring a compact footprint. The PowerFlex 700L drive offers two versions of control: either the PowerFlex 700 Vector Control or the PowerFlex 700S Phase II Control. This provides the PowerFlex 700L drive with exceptional and proven performance as well as the same interface, communications capabilities and programming tools of the air-cooled drives. The many features allow you to easily configure the drive for most application needs. Ratings presently available include:

- 268...960 Hp (200...715 kW) at 400V AC
- 300...1150 Hp (224...860 kW) at 480V AC
- 465...870 Hp (345...650 kW) at 600V AC
- 475...881 Hp (355...657 kW) at 690V AC

Key Features/Benefits

Space Saving Features

The PowerFlex 700L AC drive features a patented liquid-cooled heatsink design to transfer over 80% of the drive heat loss to the liquid coolant, resulting in the best drive power-to-size ratio in the market. The integral active converter and line filter translate to a fully regenerative drive that's over 60% smaller than typical air-cooled drives.

Integrated Line Regenerative Braking For Precise Control and Energy Savings

- The Liquid-cooled AC drive features regenerative braking which is ideal for precise, high-response speed and position control, continuous holdback, rapid deceleration and stopping of high inertia loads. Instead of wasting energy with resistor braking technology, regenerative braking actually puts the energy back into the system to be used by other equipment.
- Regenerative braking eliminates the need for large resistor banks. These resistor banks can create a lot of heat and must frequently be cleaned.

Improved Power Quality with Regenerative Rectifier

- Compact and cost-effective means to achieve compliance with IEEE 519 harmonic limits.
- Actively controls power factor regardless of motor speed which reduces input line currents and minimizes the size of upstream devices.
- Input Voltage Boost
- Integrated active converter and line-side filter allow 'input voltage boost' to protect your system from power disturbances.
- Maintains consistent system performance in the event of power dips or other power quality issues.
- Provides full 480V AC to the motor even when operating on 380V AC power lines.

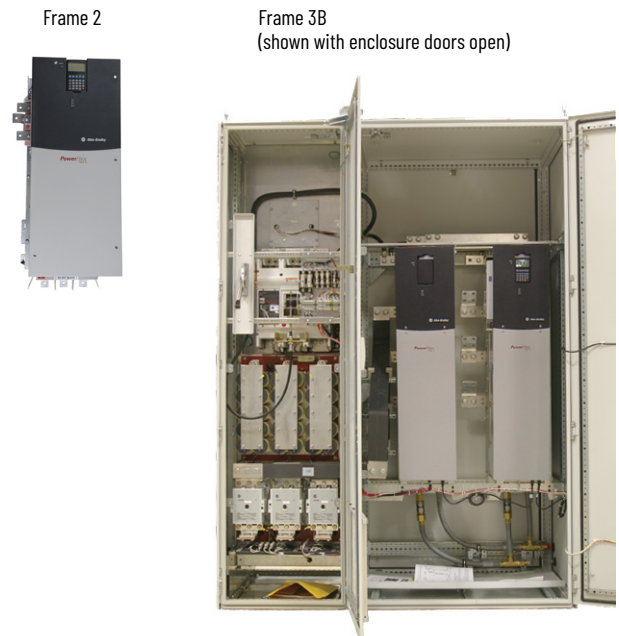

Flexible Control Platforms

- Designed for applications with requirements ranging from the simplest speed control to the most demanding torque control, the PowerFlex 700L drive is available with either PowerFlex 700 Vector Control or PowerFlex 700S Control.
- Outstanding open or closed loop speed regulation for applications ranging from fans and pumps to precise winder control.
- Excellent torque production and tight torque regulation for demanding applications like extruders, web process, and test stands.
- Fast update times of torque inputs are suitable for high performance applications.
- All of this flexibility is possible through multiple control modes: V/Hz control, Sensorless Vector, Vector Control with FORCE Technology, and Permanent Magnet Control (700S control only).
- Safe Torque Off Option (available with the PowerFlex 700S Control option), the first offering available within the DriveGuard™ series of safety solutions, prevents a drive from delivering rotational energy to motors by integrating a safety circuit with the drive's power switching signals. This solution meets EN13849-1, Category 3.



PowerFlex 700L drives with Safe Torque Off manufactured before 09/25/2020 are TUV certified.

Packaging Options

- The PowerFlex 700L frame 2 is an IP00 (Open Style) panel mount drive that can be mounted in a variety of enclosures.
- The PowerFlex 700L frame 3A and 3B are available in a IP20 (NEMA 1) Rittal enclosure that includes the input circuit breaker.
- The majority of heat lost from the drive is transferred to the liquid coolant. Therefore, other enclosure options such as IP54 (NEMA/UL Type 12) or IP66 (NEMA/UL Type 4X) can be used and placed directly into dusty, dirty, and outdoor environments. Contact your local Rockwell Automation drive center for these packaging options.

Cooling Loop Options

A liquid-to-liquid or liquid-to-air heat exchanger, or a chiller can be used with the PowerFlex 700L drive. See [page 40](#) for more information.

Communication and Human Interface Options

Premier Integration with PowerFlex Drives and RSLogix 5000 Software

For simplified AC drive start-up and reduced development time, we've integrated Allen-Bradley PowerFlex drive configuration with RSLogix™ 5000 software. This single-software approach simplifies parameter and tag programming while still allowing stand-alone drive software tool use on the factory floor.

Communication Modules

DPI communication modules provide fast and efficient control and/or data exchange over:

- DeviceNet™ interface
- ControlNet™ interface
- EtherNet/IP™ interface
- Serial communications
- Other open control and communication networks

Unsurpassed Capability in Network Communications

PowerFlex drives are fully compatible with the wide variety of Allen-Bradley DPI™ communication adapters, offering the following benefits.

DeviceNet	ControlNet	EtherNet/IP	RS-485 DF1	PROFIBUS DP	CANopen	Modbus RTU	Modbus TCP	Metasys N2	Siemens PI FLN	Description
x	x	x								Unconnected Messaging permits other network devices (for example, PanelView™ terminal) to communicate directly to a drive without routing the communication through the network scanner.
x	x	x	x			x				Adapter Routing - Plug PC into one drive and talk to all other Allen-Bradley drives on same network, without being routed through the network scanner.
x	x	x	x	x	x	x	x	x	x	Access to 100% of all parameters over the network.
x		x		x						AutoBaud capability makes initial connections less problematic.
x										Change of State significantly reduces network traffic by configuring control messages to be sent only upon customer defined states. Very flexible configuration for each node (Example: 'reference must change by more than 5%').
x		x								Peer Control provides master-slave type control between drives, where one or more slave drives (consumers) can run based on the status of a master drive (producer), which can also significantly reduce network traffic.
x										Automatic Device Replacement (ADR) saves significant time and effort when replacing a drive, by allowing the scanner to be configured to automatically detect a new drive and download the required parameter settings.
x	x	x	x	x	x	x	x	x	x	Flexible Fault Configuration - Adapters can be programmed to take fault based actions such as ramp to stop, coast-to-stop, and hold last state, as well as send user configurable logic control and speed reference values. In addition, different actions can be taken based on whether the network experienced a serious problem (broken cable, and so forth) versus a network idle condition (PLC set to 'Program').

PowerFlex Architecture-Class LCD Human Interface Modules

- An LCD Human Interface Module (also used with the PowerFlex 70, PowerFlex 700, and PowerFlex 700S) provides multilingual text for startup, metering, programming, and troubleshooting.
- Large and easy to read 7 line x 21 character backlit display
- Alternate function keys for shortcuts to common tasks
- 'Calculator-like' number pad for fast and easy data entry (Full Numeric version only)
- Control keys for local start, stop, speed, and direction
- Remote versions for panel mount applications

PC-based Configuration Tools

Connected Components Workbench Software

Connected Components Workbench™ software design and device configuration software, offers device configuration, controller programming, and integration with HMI editor. Connected Components Workbench software is developed based on proven Rockwell Automation® and Microsoft® Visual Studio technology. Connected Components Workbench software has compatibility with:

- RSLinx® Classic Lite version 2.59.02 or greater
- ControlFLASH™ version 11.00 or greater

DriveTools™ SP Software

A powerful personal computer-based software suite, for programming, configuration, and troubleshooting.

- DriveExecutive™ - for online and offline configuration and management of drives and drive peripherals
- DriveObserver™ - for real time trending of drive information

See the PowerFlex Low Voltage AC Drives Selection Guide, publication [PFLEX-SG002](#), for information on other software configuration tools.



DriveTools SP Software has been upgraded to Connected Components Workbench. DriveTools support can be found at the Product Compatibility Download Center rok.auto/pcdc, but is not longer available for sale.

Catalog Number Explanation

1-3	4	5-7	8	9	10	11	12	13	14	15	16	17	18
20L	E	800	A	0	E	N	N	A	N	1	0	W	A
a	b	c	d	e	f	g	h	i	j	k	l	m	n

a

Drive	
Code	Type
20L	PowerFlex 700L

b

Voltage Rating		
Code	Voltage	Ph.
C	400V AC	3
D	480V AC	3
E	600V AC	3
F	690V AC	3

c1

ND Rating			
400V, 60 Hz Input			
Code	Amps	Hp (KW)	Frame
360 ⁽¹⁾	360	268 (200)	2
650	650	500 (370)	3A
1K2	1250	960 (715)	3B

(1) PowerFlex 700L Frame 2 ratings are no longer available for sale.

c2

ND Rating			
480V, 60 Hz Input			
Code	Amps	Hp (KW)	Frame
360	360	300 (224)	2
650	650	600 (445)	3A
1K2	1250	1150 (860)	3B

c3

ND Rating			
600V, 60 Hz Input			
Code	Amps	Hp (KW)	Frame
425	425	465 (345)	3A
800	800	870 (650)	3B
1K1	1175	1275 (950)	3B ⁽¹⁾

(1) Must operate at 2 kHz PWM only, and only as a stand-alone inverter module ("K" in position 13).

c4

ND Rating			
690V, 60 Hz Input			
Code	Amps	Hp (KW)	Frame
380	380	475 (355)	3A
705	705	881 (657)	3B
1K0	1050	1310 (980)	3B ⁽¹⁾

(1) Must operate at 2 kHz PWM only, and only as a stand-alone inverter module ("K" in position 13).

d

Enclosure		
Code	Type	Conformal Coating
A	NEMA/UL Type 1, IP20 ⁽¹⁾	Yes
N	Open-Chassis Style/IP00 ⁽²⁾	Yes

(1) Frame 3 complete drive.
 (2) Frame 2 drive and frame 3 input filter and power modules.

e

HIM	
Code	Operator Interface
0	No HIM/Blank Cover
3	Full Numeric LCD ⁽¹⁾
C	Door-Mounted Full Numeric LCD ⁽²⁾

(1) Frame 2 and frame 3 power modules.
 (2) Frame 3 complete drive only.

f

Documentation		
Code	Documents	Ship Carton
E	English Doc Set	Yes
N	No Documentation	Yes
Q	No Documentation	No

g

Brake	
Code	w/Brake IGBT
N	No

h

Brake Resistor	
Code	w/Resistor
N	No

i

Equipment Type		
Code	Description	Frame
A	Complete Regenerative Drive - Std. Interrupt Rating	2, 3A, and 3B
C	Input Filter	3A and 3B
E	Combined Active Converter/Inverter Power Module	3A only
G	Active Converter Power Module	3B only
J	Inverter Power Module - Coupled Version	3B only
K	Inverter Power Module - Common DC Bus Version	3B only
L	Dual Inverter Power Module	3A only
P	Active Converter Power Module - Stand Alone Version	3B only
X	Spare Power Module ⁽¹⁾	3A and 3B

(1) No control cassettes.

j

Comm Slot		
Code	Communication Option	DPI User-Installed Kit Cat. No.
N	None	N
C	ControlNet (Coax) - DPI	20-COMM-C
D	DeviceNet - DPI	20-COMM-D
E	EtherNet/IP - DPI	20-COMM-E

Position													
1-3	4	5-7	8	9	10	11	12	13	14	15	16	17	18
20L	E	800	A	O	E	N	N	A	N	1	0	W	A
a	b	c	d	e	f	g	h	i	j	k	l	m	n

k Control Option				
Code	Control	Cassette	Logic Expansion	Synch Link
1	700VC 24V I/O	Base	N/A	N/A
2	700VC 115V I/O	Base	N/A	N/A
A	700S Ph. II	Expanded	No	No
B	700S Ph. II	Expanded	No	Yes
C	700S Ph. II	Expanded	Yes	No ⁽¹⁾
D	700S Ph. II	Expanded	Yes	Yes ⁽¹⁾
W	None ⁽²⁾	N/A	N/A	N/A

l Feedback		
Code	Control Option	Type
0	All	None
1	700VC	Encoder 5V/12V
E	700S Ph. II	2nd Encoder ⁽¹⁾ r
S	700S Ph. II ⁽²⁾	Safe Torque Off (w/2nd Encoder) ⁽¹⁾

(1) Requires expanded cassette.
 (2) PowerFlex 700L drives with Safe Torque Off manufactured before 09/25/2020 are TUV certified.

m Additional 700S Configuration		
Code	Logix Option	Embedded Comm.
W	None	—
E	Phase II Control	No
K	Phase II Control with DriveLogix 5730	No

n Coolant Type		
Code	Coolant	Frame
N	None	3 Input Filter only
A	Water	All

(1) Requires DriveLogix5730.
 (2) Frame 3 input filter, Active Converter Power Modules, and spare power modules.

Standard Drive Product Selection

400V AC Three-phase Drives

Output Amps (with 400V AC Induction Motor) ⁽¹⁾						Nominal Power Ratings				IP20, NEMA/UL Type 1 ⁽²⁾	Frame Size	PWM Freq. (kHz)
Normal Duty			Heavy Duty			Normal Duty		Heavy Duty		Cat. No.		
Cont.	110% 1 min	150% 3 s	Cont.	150% 1 min	200% 3 s	kW	Hp	kW	Hp			
360	396	540	264	396	540	200	268	150	200	20LC360NOENNAN10WA	2	4
650	715	975	475	715	975	370	500	270	365	20LC650AOENNAN10WA	3A	4
1250	1375	1875	915	1375	1875	715	960	525	700	20LC1K2AOENNAN10WA	3B	4

(1) Frame 2 ratings are based on 50 °C ambient and 50 °C coolant. Frame 3A and 3B ratings are based on 40 °C ambient and 40 °C coolant.

(2) Frames 3A and 3B only. Frame 2 drives are IP00, NEMA/UL Type Open.

480V AC Three-phase Drives

Output Amps (with 480V AC Induction Motor) ⁽¹⁾						Nominal Power Ratings				IP20, NEMA/UL Type 1 ⁽²⁾	Frame Size	PWM Freq. (kHz)
Normal Duty			Heavy Duty			Normal Duty		Heavy Duty		Cat. No.		
Cont.	110% 1 min	150% 3 s	Cont.	150% 1 min	200% 3 s	kW	Hp	kW	Hp			
360	396	540	264	396	540	224	300	175	235	20LD360NOENNAN10WA	2	4
650	715	975	475	715	975	445	600	325	440	20LD650AOENNAN10WA	3A	4
1250	1375	1875	915	1375	1875	860	1150	630	845	20LD1K2AOENNAN10WA	3B	4

(1) Frame 2 ratings are based on 50 °C ambient and 50 °C coolant. Frame 3A and 3B ratings are based on 40 °C ambient and 40 °C coolant.

(2) Frames 3A and 3B only. Frame 2 drives are IP00, NEMA/UL Type Open.

600V AC Three-phase Drives

Output Amps (with 600V AC Induction Motor) ⁽¹⁾						Nominal Power Ratings				IP20, NEMA/UL Type 1	Frame Size	PWM Freq. (kHz)
Normal Duty			Heavy Duty			Normal Duty		Heavy Duty		Cat. No.		
Cont.	110% 1 min	150% 3 s	Cont.	150% 1 min	200% 3 s	kW	Hp	kW	Hp			
425	470	640	315	470	640	345	465	255	345	20LE425AOENNAN10WA	3A	4
800	885	1200	590	885	1200	650	870	480	640	20LE800AOENNAN10WA	3B	4
1175	1295	1765	860	1295	1765	955	1275	695	935	20LE1K1AOENNAN10WA	3B	2 ⁽²⁾

(1) Frame 3A and 3B ratings are based on 40 °C ambient and 40 °C coolant.

(2) Must operate at 2 kHz PWM only, and only as a stand-alone inverter module ('K' in catalog string position 13).

690V AC Three-phase Drives

Output Amps (with 690V AC Induction Motor) ⁽¹⁾						Nominal Power Ratings				IP20, NEMA/UL Type 1	Frame Size	PWM Freq. (kHz)
Normal Duty			Heavy Duty			Normal Duty		Heavy Duty		Cat. No.		
Cont.	110% 1 min	150% 3 s	Cont.	150% 1 min	200% 3 s	kW	Hp	kW	Hp			
380	420	570	280	420	570	355	475	260	350	20LF380AOENNAN10WA	3A	4
705	780	1060	520	780	1060	657	881	485	650	20LF705AOENNAN10WA	3B	4
1050	1155	1575	770	1155	1575	980	1315	720	965	20LF1K0AOENNAN10WA		2 ⁽²⁾

(1) Frame 3A and 3B ratings are based on 40 °C ambient and 40 °C coolant.

(2) Must operate at 2 kHz PWM only, and only as a stand-alone inverter module ('K' in catalog string position 13).

Factory Installed Options

Human Interface and Wireless Interface Modules IP20, NEMA/UL Type 1 (Position e)



Cat. Code: 0
No HIM (Blank Plate)



Cat. Code: 3
LCD Display, Full
Numeric Keypad



Cat. Code: C
Door Mounted Bezel
LCD Display, Full
Numeric Keypad
NEMA/UL Type 1

Documentation

Description	Cat. Code (Position f)
English Documentation Set	E
No Documentation	N

Internal Communication Adapters

Description	Cat. Code (Position j)
None	N
ControlNet Communication Adapter (Coax) ‡	C
DeviceNet Communication Adapter ‡	D
EtherNet/IP Communication Adapter ‡	E

‡ 700 Vector Control uses DPI comm. slot options only.

Control Options

Control Option	Description	Cat. Code (Position k)
700VC - 24V I/O	Base Cassette	1
700VC - 115V I/O	Base Cassette	2
Phase II Control	Expanded Cassette Only	A
	Expanded Cassette w/SynchLink	B
Phase II Control *	Expanded Cassette w/Logix Expansion Board	C
	Expanded Cassette w/Logix Expansion Board & SynchLink	D

* Requires DriveLogix 5730.

Feedback Options

Control Type	Description	Cat. Code (Position l)
All	No Encoder	0
700VC	12V/5V Encoder	1
700S Phase II	2nd Encoder, 5V or 12V Configurable by the Drive	E
	DriveGuard Safe Torque Off (w/2nd Encoder) «	S

§ Requires Expanded Cassette.

« PowerFlex 700L drives with Safe Torque Off manufactured before 09/25/2020 are TUV certified.

Additional 700S Configurations

Description	Embedded Communication	Cat. Code (Position m)
None	-	W
Phase II Control	No	E
Phase II Control, with DriveLogix5730 Controller	No	K

Coolant Options

Description	Frame	Cat. Code (Position n)
Water	All	A

User Installed Options

Human Interface Modules



No HIM (Blank Plate)
20-HIM-A0

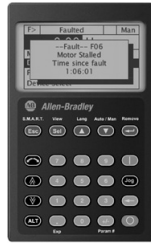

LCD Display, Full
Numeric Keypad
20-HIM-A3



LCD Display,
Programmer Only
20-HIM-A5



Remote (Panel Mount) LCD
Display, Full Numeric
Keypad
20-HIM-C3S (1)(2)



Remote (Panel Mount) LCD
Display, Programmer Only
20-HIM-C5S (1)(2)



LCD Display, Full Numeric
Keypad, Handheld/Local,
Drive Mounted, NEMA Type 1
20-HIM-A6(1)

(1) For indoor use only.

(2) Includes a 1202-C30 interface cable (3 m) for connection to drive.



LCD Display, Full Numeric Keypad,
IP66 NEMA Type 4X/12
20-HIM-C6S (1)(2)

(1) For indoor use only.

(2) Includes a 1202-C30 interface cable (3 m [9.8 ft]) for connection to drive.

Human Interface Module Accessories

Description	Cat. No.
Bezel Kit for LCD HIMs, NEMA/UL Type 1 ⁽¹⁾	20-HIM-B1
PowerFlex HIM Interface Cable, 1 m (39 in) ⁽²⁾	20-HIM-H10
Cable Kit (Male-Female) ⁽³⁾	
0.33 m (1.1 ft)	1202-H03
1 m (3.3 ft)	1202-H10
3 m (9.8 ft)	1202-H30
9 m (29.5 ft)	1202-H90
DPI/SCANport™ One to Two Port Splitter Cable	1203-S03

(1) Includes an interface cable (1202-C30) for connection to drive.

(2) Required only when HIM is used as handheld or remote.

(3) Required in addition to 20-HIM-H10 for distances up to a total maximum of 10 m (32.8 ft).

Communication Option Kits

Description	Cat. No.
ControlNet Communication Adapter (Coax)	20-COMM-C
DeviceNet Communication Adapter	20-COMM-D
EtherNet/IP Communication Adapter	20-COMM-E
HVAC Communication Adapter ⁽¹⁾	20-COMM-H
CANopen Communication Adapter	20-COMM-K
Modbus/TCP Communication Adapter	20-COMM-M
PROFIBUS DP Communication Adapter	20-COMM-P
ControlNet Communication Adapter (Fiber)	20-COMM-Q
RS485 DF1 Communication Adapter	20-COMM-S
Dual-Port EtherNet/IP Communication Adapter	20-COMM-ER
DriveLogix5730 Comm Option, Embedded EtherNet/IP	20D-DL2-ENETO
External Communications Kit Power Supply	20-XCOMM-AC-PS1
DPI External Communications Kit ⁽²⁾	20-XCOMMDC-BASE

(1) For use only in Modbus RTU mode.

(2) For use only with DPI External Communications Kits 20-XCOMM-DCBASE.

Communication Accessories

Description	Cat. No.
Universal Serial Bus (USB) Converter includes 2 m USB, 20-HIM-H10 and 22-HIM-H10 Cables	1203-USB
ControlNet Ex Right-Angle T-Tap 1 Meter Coax Cable Assembly	1786-TPR

Feedback Option Kits

Description	Cat. No.
Multi-Device Interface ⁽¹⁾⁽²⁾	20D-MDI-C2
DriveGuard Safe Torque Off (w/2nd Encoder) ⁽¹⁾⁽²⁾⁽³⁾	20D-P2-DG01
Second Encoder, 5V/12V ⁽¹⁾⁽²⁾	20D-P2-ENCO
Resolver ⁽¹⁾⁽²⁾	20D-RES-A1
Stegmann High-Resolution Hyperface Encoder ⁽¹⁾⁽²⁾	20D-STEG-B1
12V/5V Encoder ⁽⁴⁾	20B-ENC-1

(1) Requires expanded cassette.

(2) When using a PowerFlex 700S, Control only.

(3) PowerFlex 700L drives with Safe Torque Off manufactured before 09/25/2020 are TUV certified.

(4) When using a PowerFlex 700, Vector Control only.

Phase II Drive Control Kits

Description	Cat. No.
PowerFlex 700S Phase II Control with Expanded Cassette	20D-P2-CKE2
PowerFlex 700S Phase II Control with Slim Cassette	20D-P2-CKS2
PowerFlex 700S DriveLogix5730 Phase II Control with Expanded Cassette	20D-DL2-CKE2
PowerFlex 700S DriveLogix5730 Phase II Control with Slim Cassette	20D-DL2-CKS2

Product Dimensions

Frame 2 Drive

Dimensions are in millimeters and (inches).

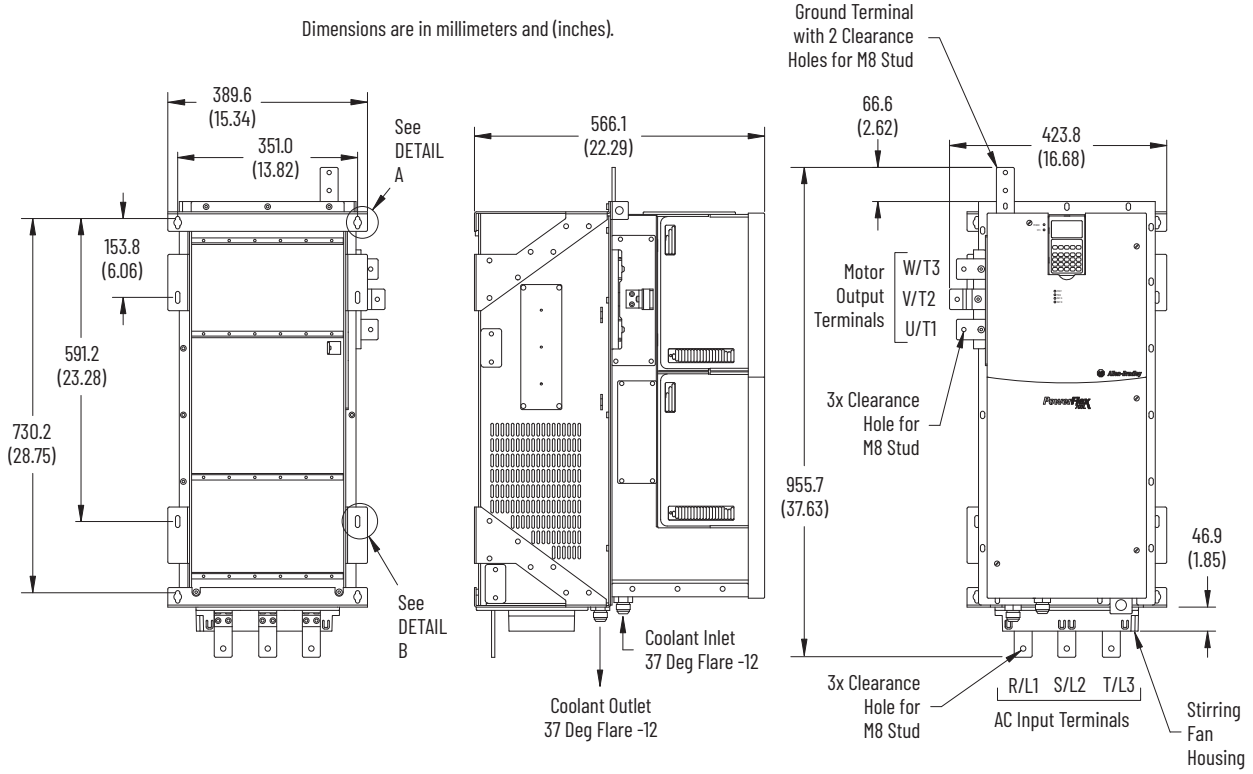

BACK VIEW

SIDE VIEW

FRONT VIEW

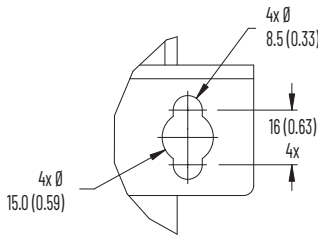

DETAIL A

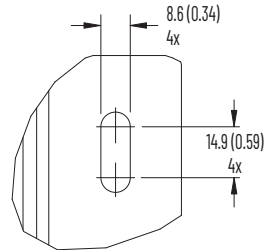

DETAIL B

Weight: 186 kg (410 lb)

Frame 3A/3B Drive

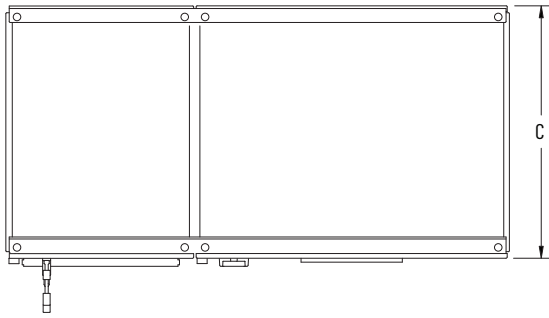

Dimensions are in millimeters and (inches).

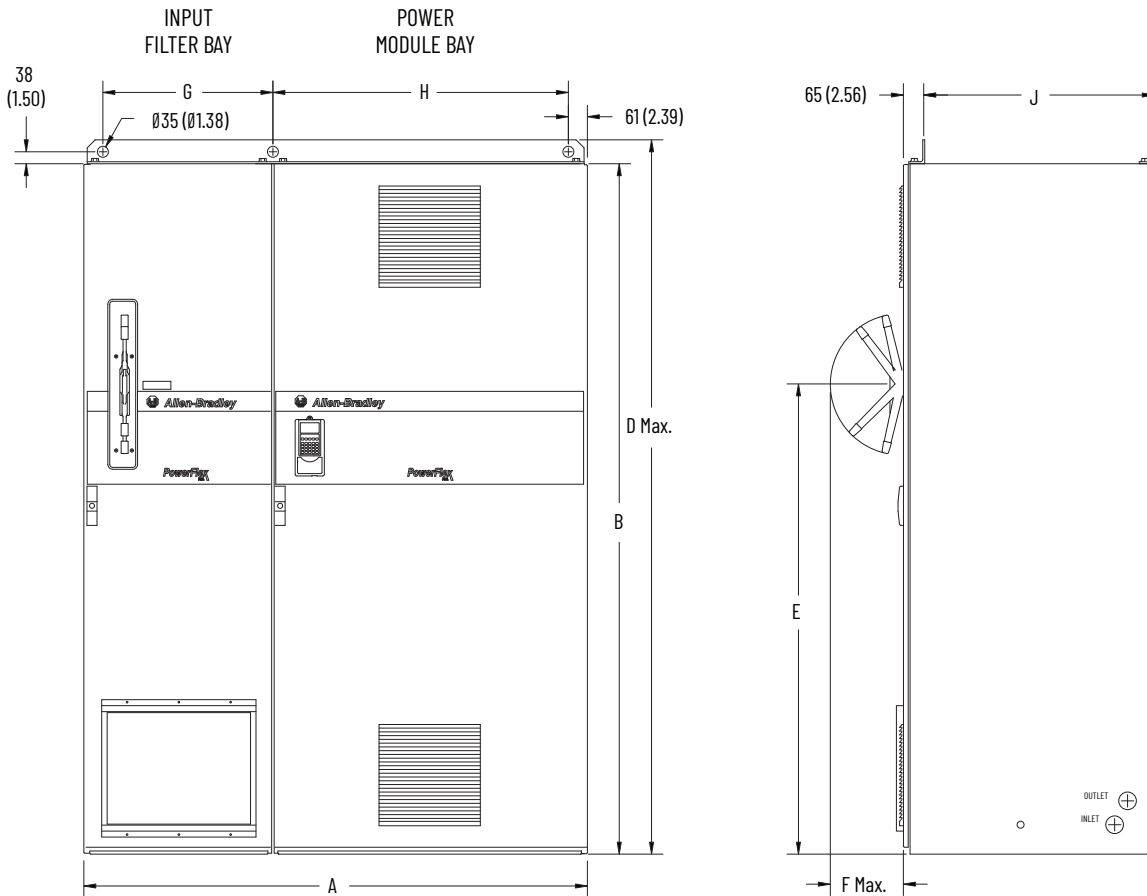

Frame Size	Dimensions									Weight kg (lb)
	A	B	C	D	E	F	G	H	J	Complete Drive
3A	1200 (47.2)	2000 (78.7)	600 (23.6)	2078 (81.9)	1500 (59.1)	233 (9.2)	542 (21.3)	542 (21.3)	535 (21.1)	950 (2090)
3B	1600 (63.0)	2200 (86.6)	800 (31.5)	2278 (89.8)	1500 (59.1)	233 (9.2)	542 (21.3)	942 (37.1)	735 (28.9)	1361 (3000)

Installation Considerations

Power Wiring

The PowerFlex 700L has the following built-in protective features to help simplify installation:

- Ground fault protection during start up and running ensures reliable operation
- Electronic motor overload protection increases motor life

AC Supply Source Considerations

PowerFlex 700L Liquid-cooled AC drives are suitable for use on a circuit capable of delivering up to a maximum of 200,000 rms symmetrical amperes.

PowerFlex 700L Liquid Cooled AC drives should not be used on undersized or high-impedance supply systems. The supply system kVA should be equal to or greater than the drive-rated kW, and the system impedance should be less than 10%. Operation outside these limits could cause instability resulting in drive shutdown.

PowerFlex 700L Liquid Cooled AC drives have a built-in LCL filter which includes a 3% input line reactor. Additional input line reactors are not recommended.

Unbalanced, Ungrounded or Resistive Grounded Distribution Systems

Removable MOV to ground and common mode capacitors to ground ensure compatibility with ungrounded systems. These devices must be disconnected if the drive is installed on a resistive grounded distribution system, an ungrounded distribution system, or a B phase grounded distribution system. These devices must also be disconnected if a regenerative unit is used as a bus supply or brake.

Input Power Conditioning

Certain events on the power system supplying a drive can cause component damage or shortened product life. These events include the following:

- The power system has power factor correction capacitors switched in and out of the system, either by you or by the power company.
- The power source has intermittent voltage spikes in excess of 6000 volts. These spikes could be caused by other equipment on the line or by events such as lightning strikes.
- The power source has frequent interruptions.

There are many other factors that must be considered for optimal performance in any given application. Primary Installation Considerations on [page 15](#) highlights the primary installation considerations. For detailed recommendations on input power conditioning, reflected wave protection, and motor cable types, see the Wiring and Grounding Guidelines for PWM AC Drives, Installation Instructions, publication [DRIVES-IN001](#).

EMC Requirements

The 700VC control option for frame 2 comes with two common mode chokes—one for input and one for output. The 700S control option for frame 2 requires a field-installed kit SK-L1-CHK2-F2.

Primary Installation Considerations

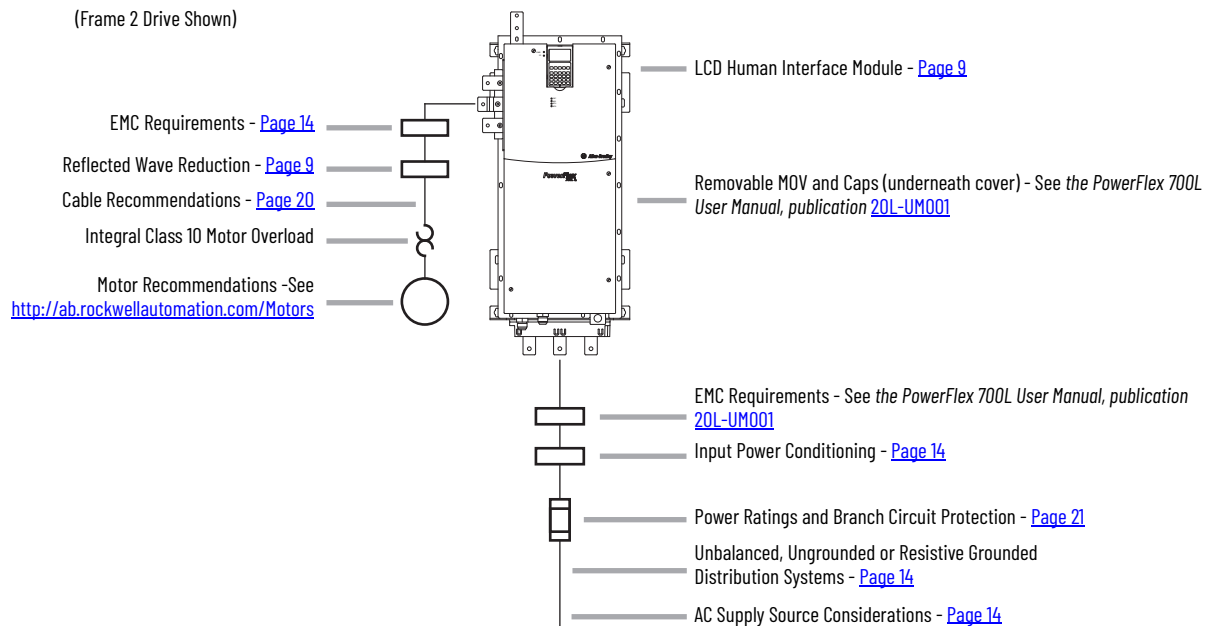

Frame 2 Drive

Recommended Mounting Clearances

Specified vertical clearance requirements are intended to be from drive to drive. Other objects can occupy this space; however, reduced air flow may cause protection circuits to fault the drive. In addition, inlet air temperature must not exceed the product specification.

Mounting Requirements

The PowerFlex700L frame 2 drive is a single integrated assembly consisting of a filter section and a power section. The filter section provides the mounting feet and represents greater than 50% of the approximately 186 kg (410 lb) total weight. Follow these mounting requirement guidelines:

- Mount the frame 2 drive into an enclosure that is designed according to Electrical Equipment Pollution Degree 2 requirements.
- Size and fasten any enclosure mounting panel appropriately to accommodate for the weight of the drive.
- See the PowerFlex 700L User Manual, publication [20L-UM001](#), for detailed mounting instructions.

Determining Wire Routing for Control, Ground, Drive Input, and Motor Output

All wiring should be installed in conformance with the applicable local, national, and international codes (for example, NEC/CEC). Signal wiring, control wiring, and power wiring must be routed in separate conduits to prevent interference with drive operation. When hubs are not provided, use grommets to guard against wire chafing.

Do not route signal and control wiring with power wiring in the same conduit. This can cause interference with drive operation. Failure to observe this precaution can result in damage to, or destruction of, the equipment.

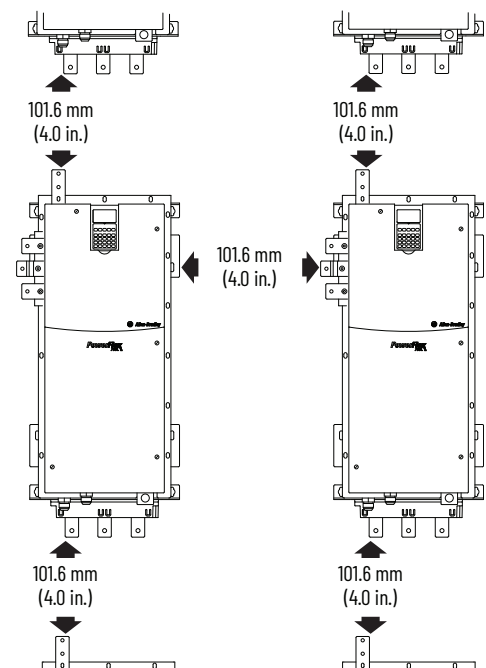

Do not route more than three sets of motor leads through a single conduit. This minimizes cross-talk that can reduce the effectiveness of noise reduction methods. If more than three drive/motor connections per conduit are required, shielded cable must be used. If possible, each conduit should contain only one set of motor leads.

Frame 2 Locations for Control Wire Routing, DPI Communication Port, and Coolant Connections

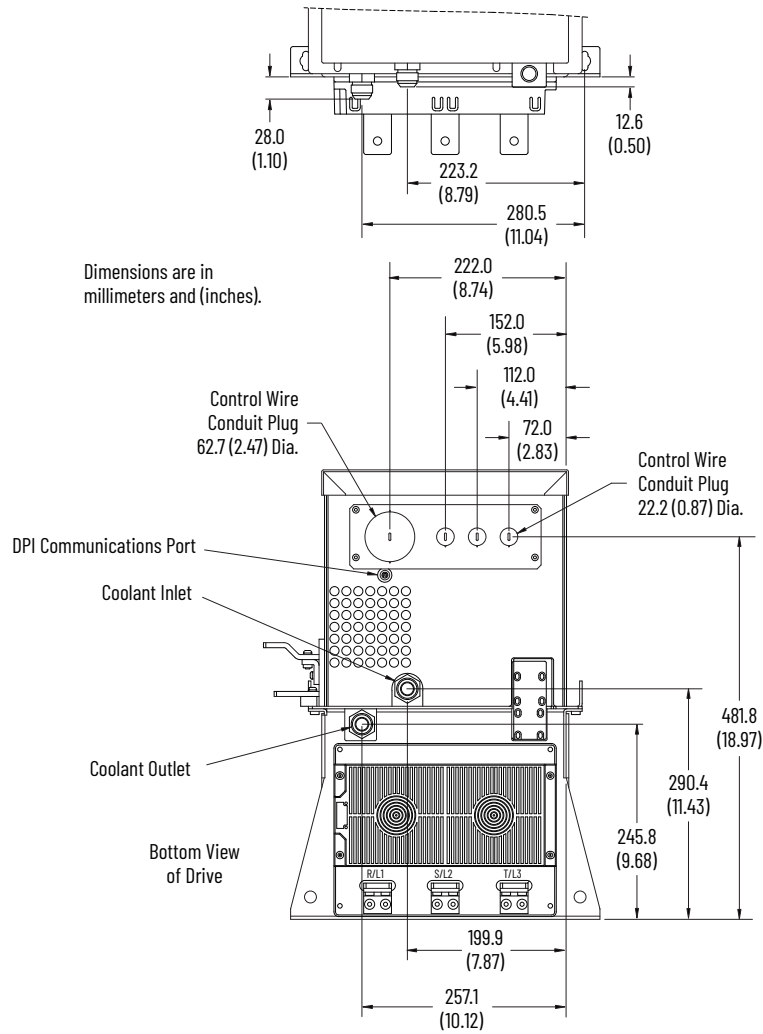

Frame 2 Power Terminal Locations

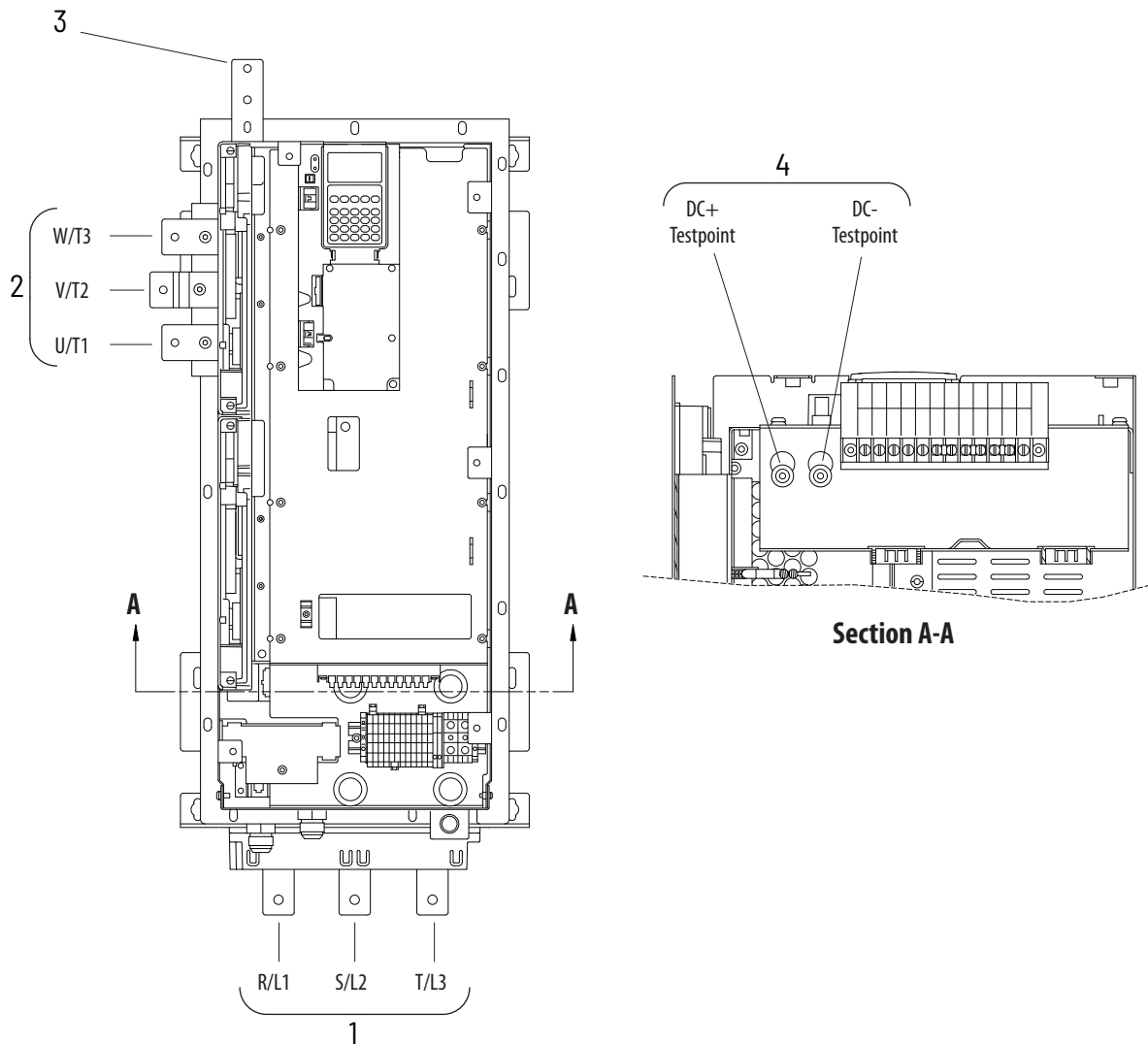

Frame 2 Power Terminal Specifications

Item	Name	Description	Recommended Tightening Torque ($\pm 10\%$)	Terminal Bolt Size ⁽¹⁾
1	Input Power Bus Bar ⁽²⁾ R/L1, S/L2, T/L3	Input power	40 N•m (354 lb•in)	M8
2	Output Power Bus Bar ⁽²⁾ U/T1, V/T2, W/T3	Motor connections	40 N•m (354 lb•in)	M8
3	PE, Motor Ground Bus Bar ⁽²⁾	Terminating point for wiring shields and grounds	40 N•m (354 lb•in)	M8
4	DC Bus Test Point Socket ⁽³⁾ (2 Terminals; DC+, DC-)	4 mm socket for DC bus voltage measurement only	—	—

(1) Apply counter torque to the nut on the other side of terminations when tightening or loosening the terminal bolt to avoid damage to the terminal.

(2) These connections are bus bar type terminations and require the use of lug connectors.

(3) Use only to verify that DC bus capacitors are discharged before servicing the power module. No other external use is permitted.

Frame 3A/3B Drive

Recommended Mounting Clearances

Verify that there is adequate clearance for air circulation around the drive enclosures. A 15 cm (6 in.) minimum clearance is required wherever vents in the cabinet are located.

Determining Wire Routing for Control, Ground, Drive Input, and Motor Output

All wiring should be installed in conformance with the applicable local, national, and international codes (for example, NEC/CEC). Signal wiring, control wiring, and power wiring must be routed in separate conduits to prevent interference with drive operation. When hubs are not provided, use grommets to guard against wire chafing.

Do not route signal and control wiring with power wiring in the same conduit. This can cause interference with drive operation. Failure to observe this precaution can result in damage to, or destruction of, the equipment.

Do not route more than three sets of motor leads through a single conduit. This minimizes cross-talk that can reduce the effectiveness of noise reduction methods. If more than three drive/motor connections per conduit are required, shielded cable must be used. If possible, each conduit should contain only one set of motor leads.

Frame 3A Power Terminal Locations

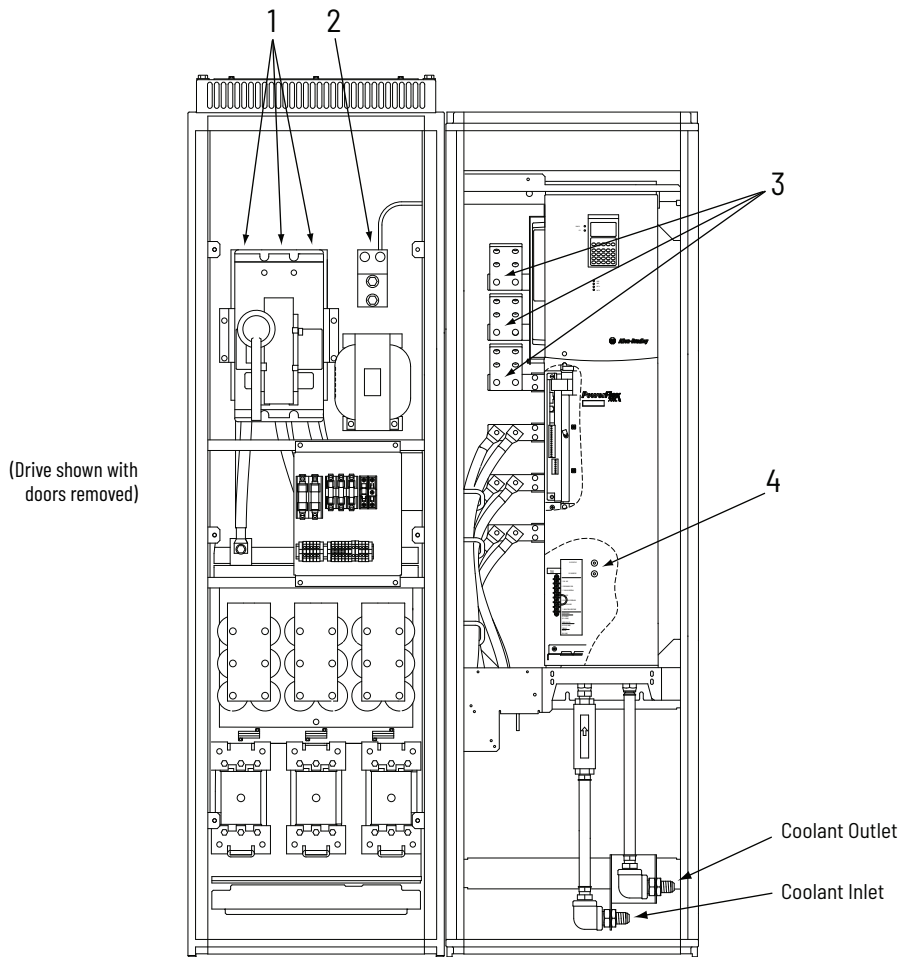

Frame 3B Power Terminal Locations

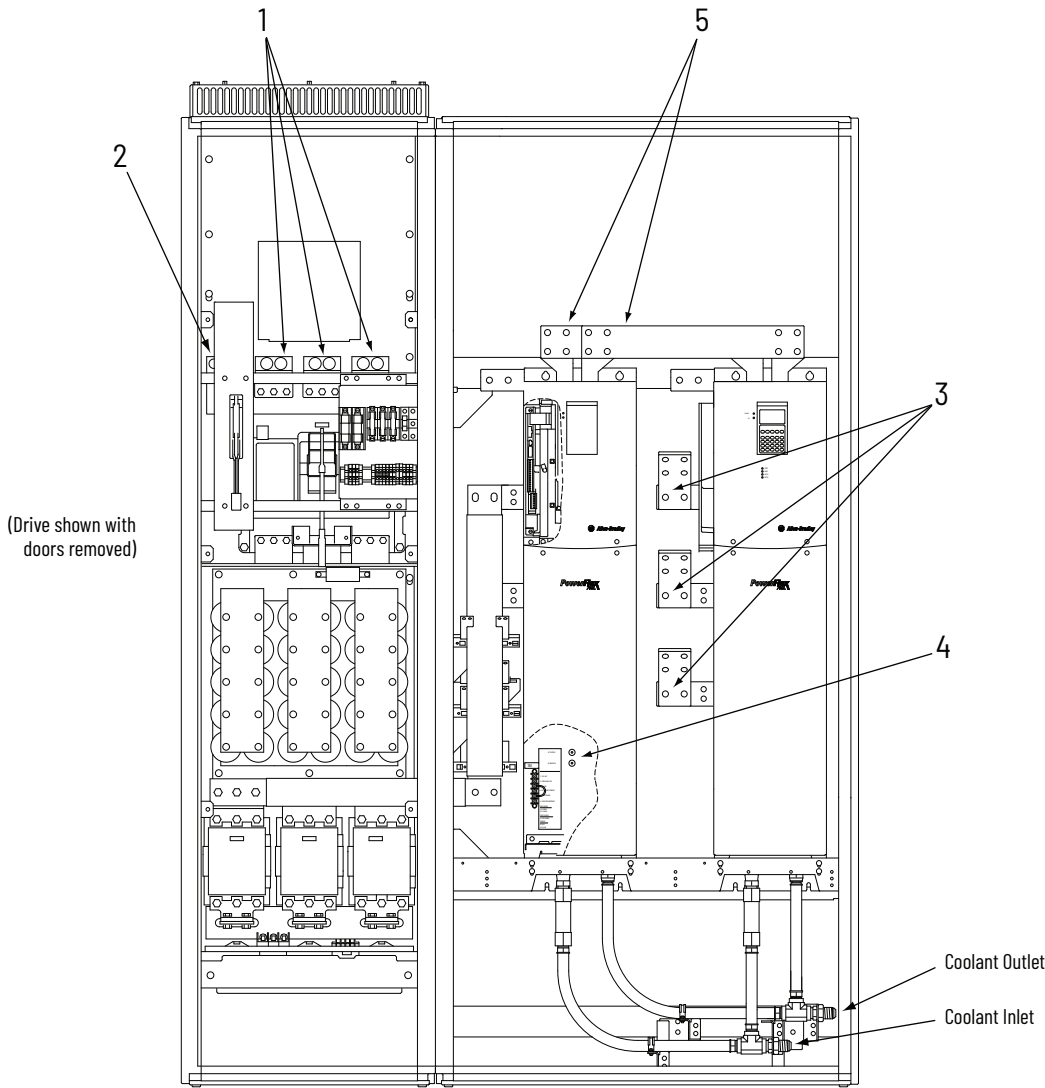

Frame 3A/3B Power Terminal Specifications

Item	Name	Description	Frame Size	Wire Size Range ⁽¹⁾		Recommended Tightening Torque ($\pm 10\%$)
				Maximum	Minimum	
1	Input Power Wire Lugs R/L1, S/L2, T/L3	Input power connections on drive	3A	400 MCM	3/0	42 N•m (375 lb•in)
			3B	1000 MCM	500 MCM	62 N•m (550 lb•in)
2	PE Wire Lug	Terminating point for ground wires	3A or 3B	600 MCM	# 2 AWG	34 N•m (300 lb•in)
3	Output Power Bus Bar ⁽²⁾ U/T1, V/T2, W/T3	Motor connections	3A or 3B			62 N•m (550 lb•in)
4	DC Bus Test Point Socket ⁽³⁾ (2 Terminals; DC+, DC-)	4 mm socket for DC bus voltage measurement only	3A or 3B	—	—	—
5	DC Power Bus Bar ⁽²⁾ ⁽⁴⁾ (2 Terminals; DC+, DC-)	DC power from Converter Power Module to Inverter Power Module	3B			62 N•m (550 lb•in)

(1) Maximum/minimum sizes that the terminals will accept - these are not recommendations.
 (2) These connections are bus bar type terminations and require the use of lug connectors.
 (3) Use only to verify that DC bus capacitors are discharged before servicing the power module. No other external use is permitted.
 (4) Size DC power conductors for current carrying capacity as follows: 400/480V, 1000 Amps; 600/690V, 800 Amps.

Cable Recommendations

Cable Types Acceptable for 200-600 Volt Installations

A variety of cable types are acceptable for drive installations. For many installations, unshielded cable is adequate, provided it can be separated from sensitive circuits. As an approximate guide, allow a spacing of 0.3 m (1 ft) for every 10 m (32.8 ft) of length. In all cases, long parallel runs must be avoided. Do not use cable with an insulation thickness less than or equal to 15 mils (0.4 mm/0.015 in.). **Use Copper wire only.** Wire gauge requirements and recommendations are based on 75 °C (167 °F). Do not reduce wire gauge when using higher temperature wire. See the table on [Page 20](#).

Unshielded Cable

THHN, THWN, or similar wire is acceptable for drive installation in dry environments provided adequate free air space and/or conduit fill rate limits are used. **Do not use THHN or similarly coated wire in wet areas.** Any wire chosen must have a minimum insulation thickness of 15 mils (0.4 mm/0.015 in.) and should not have large variations in insulation concentricity.

Shielded Cable

Shielded cable contains all of the general benefits of multi-conductor cable with the added benefit of a copper braided shield that can contain much of the noise generated by a typical AC drive. Strong consideration for shielded cable should be given in installations with sensitive equipment such as weigh scales, capacitive proximity switches, and other devices that may be affected by electrical noise in the distribution system. Applications with large numbers of drives in a similar location, imposed EMC regulations, or a high degree of communication/networking are also good candidates for shielded cable.

Shielded cable may also help reduce shaft voltage and induced bearing currents for some applications. In addition, the increased impedance of shielded cable may help extend the distance that the motor can be located from the drive without the addition of motor protective devices such as terminator networks. See 'Reflected Wave' in Wiring and Grounding Guidelines for Pulse Width Modulated (PWM) AC Drives, publication [DRIVES-IN001](#).

Consideration should be given to all of the general specifications dictated by the environment of the installation, including temperature, flexibility, moisture characteristics, and chemical resistance. Additionally, a braided shield should be included and be specified by the cable manufacturer as having coverage of at least 75%. An additional foil shield can greatly improve noise containment.

A good example of recommended cable is Belden[®] 29528-29532 (AWG-1 through AWG-410). This cable has three XLPE insulated conductors plus ground with a spiral copper shield surrounded by a PVC jacket.

Other types of shielded cable are available, but the selection of these types may limit the allowable cable length. Particularly, some of the newer cables twist 4 conductors of THHN wire and wrap them tightly with a foil shield. This construction can greatly increase the cable charging current required, and reduce the overall drive performance. These cables are not recommended.

Armored Cable

Cable with continuous aluminum armor is often recommended in drive system applications or specific industries. It offers most of the advantages of standard shielded cable and also combines considerable mechanical strength and resistance to moisture. It can be installed in concealed and exposed manners and removes the requirement for conduit (EMT) in the installation. It can also be directly buried or embedded in concrete.

Because noise containment can be affected by incidental grounding of the armor to building steel when the cable is mounted, we recommend that the armor cable have an overall PVC jacket. For details, see 'Wire Types' in Wiring and Grounding Guidelines for Pulse Width Modulated (PWM) AC Drives, publication [DRIVES-IN001](#).

Interlocked armor is acceptable for shorter cable runs, but continuous welded armor is preferred.

Best performance is achieved with three spaced ground conductors, but acceptable performance for drives below 200 Hp is provided by way of a single ground conductor.

Location	Cable Rating/Type	Description
Standard (Option 1)	1000V, 90 °C (194 °F) XHHW2/RHW-2 Anixter B29528-B29532, Belden 29528-29532, or equivalent	<ul style="list-style-type: none"> Four tinned copper conductors with XLPE insulation. Copper braid/aluminum foil combination shield and tinned copper drain wire. PVC jacket.
Standard (Option 2)	Tray rated 1000V, 90 °C (194 °F) RHH/RHW-2 Anixter OLFLEX-76xxx03, or equivalent	<ul style="list-style-type: none"> Three tinned copper conductors with XLPE insulation. Corrugated copper tape with three bare copper grounds in contact with shield. PVC jacket.
Class I & II; Division I & II	Tray rated 1000V, 90 °C (194 °F) RHH/RHW-2 Anixter 7VFD-xxxx, or equivalent	<ul style="list-style-type: none"> Three bare copper conductors with XLPE insulation and impervious corrugated continuously welded aluminum armor. Black sunlight resistant PVC jacket overall. Three copper grounds.

Cable Trays and Conduit

If cable trays or large conduits are to be used, see the guidelines in Wiring and Grounding Guidelines for Pulse Width Modulated (PWM) AC Drives, publication [DRIVES-IN001](#).

Fuse and Circuit Breaker Ratings

Most codes require that upstream branch circuit protection be provided to protect input power wiring. The frame 2 drive does not provide input power short circuit protection.

The tables on the following pages provide recommended AC line input fuse and circuit breaker information. See below for UL and IEC requirements. Sizes listed are the recommended sizes based on 40 °C (104 °F) and the U.S. NEC. Other country, state or local codes may require different ratings. Tables with DC link fuse recommendations for DC input drives are also provided.

Fusing

The recommended fuse types are listed below. If available current ratings do not match the tables provided, the next higher fuse rating should be chosen.

- IEC – BS88 (British Standard) Parts 1 & 2, EN60269-1, Parts 1 & 2⁽¹⁾, type gG fuses or equivalent should be used.
- UL – UL Class T, J or L fuses should be used.

Circuit Breakers

The 'non-fuse' listings in the following tables include inverse time circuit breakers and instantaneous trip circuit breakers (motor circuit protectors). If one of these is chosen as the desired protection method, the following requirements apply.

- IEC – Both types of circuit breakers are acceptable for IEC installations.
- UL – Only inverse time circuit breakers are acceptable for UL installations.

(1) Typical designations include, but may not be limited to the following; Parts 1 & 2: AC, AD, BC, BD, CD, DD, ED, EFS, EF, FF, FG, GF, GG, GH.

400 Volt AC Input Protection Devices

Drive Catalog Number	Frame	HP (kW) Rating		Input Rating	Dual Element Time Delay Fuse		Non-Time Delay Fuse		Circuit Breaker ⁽¹⁾	Motor Circuit Protector ⁽²⁾
		ND	HD	Amps	Min. ⁽³⁾	Max. ⁽⁴⁾	Min.	Max.	Max. ⁽⁵⁾	Max.
20LC360	2	268 (200)	—	360	500	750	500	900	900	600
		—	200 (150)	264	400	650	450	900	900	400

- (1) Circuit Breaker - inverse time breaker. For US NEC, minimum size is 125% of motor FLA. Ratings shown are maximum
- (2) Motor Circuit Protector - instantaneous trip circuit breaker. For US NEC minimum size is 125% of motor FLA. Ratings shown are maximum
- (3) Minimum protection device size is the lowest rated device that supplies maximum protection without nuisance tripping.
- (4) Maximum protection device size is the highest rated device that supplies drive protection. For US NEC, minimum size is 125% of motor FLA. Ratings shown are maximum.
- (5) Maximum allowable rating by US NEC. Exact size must be chosen for each installation.

480 Volt AC Input Protection Devices

Drive Catalog Number	Frame	HP (kW) Rating		Input Rating	Dual Element Time Delay Fuse		Non-Time Delay Fuse		Circuit Breaker ⁽¹⁾	Motor Circuit Protector ⁽²⁾
		ND	HD	Amps	Min. ⁽³⁾	Max. ⁽⁴⁾	Min.	Max.	Max. ⁽⁵⁾	Max.
20LD360	2	300 (224)	—	360	500	750	500	900	900	600
		—	235 (175)	264	400	650	450	900	900	400

- (1) Circuit Breaker - inverse time breaker. For US NEC, minimum size is 125% of motor FLA. Ratings shown are maximum
- (2) Motor Circuit Protector - instantaneous trip circuit breaker. For US NEC minimum size is 125% of motor FLA. Ratings shown are maximum
- (3) Minimum protection device size is the lowest rated device that supplies maximum protection without nuisance tripping.
- (4) Maximum protection device size is the highest rated device that supplies drive protection. For US NEC, minimum size is 125% of motor FLA. Ratings shown are maximum.
- (5) Maximum allowable rating by US NEC. Exact size must be chosen for each installation.

540 Volt DC Input Fusing

Drive Catalog Number	Frame	HP (kW) Rating		DC Input Rating	Bussmann Fuse	
		ND	HD	Amps	Amps	Catalog No.
20LC650	3A	500 (370)	365 (270)	1250 ⁽¹⁾	2000	170M6621 ⁽²⁾
20LC1K2	3B	960 (715)	700 (525)	1250	2000	170M6621 ⁽²⁾

- (1) Only the Dual Inverter for PowerFlex 700L Frame 3A is available as a DC input inverter.
- (2) Two 1000A Bussmann 170M6614 fuses per phase can also be used.

650 Volt DC Input Fusing

Drive Catalog Number	Frame	HP (kW) Rating		DC Input Rating	Bussmann Fuse	
		ND	HD	Amps	Amps	Catalog No.
20LD650	3A	600 (445)	440 (325)	1250 ⁽¹⁾	2000	170M6621 ⁽²⁾
20LD1K2	3B	1150 (860)	845 (630)	1250	2000	170M6621 ⁽²⁾

- (1) Only the Dual Inverter for PowerFlex 700L Frame 3A is available as a DC input inverter.
- (2) Two 1000A Bussmann 170M6614 fuses per phase can also be used.

810 Volt DC Input Fusing

Drive Catalog Number	Frame	HP (kW) Rating		DC Input Rating	Bussmann Fuse	
		ND	HD	Amps	Amps	Catalog No.
20LE425	3A	465 (345)	345 (255)	850 ⁽¹⁾	1400	170M6701 ⁽²⁾
20LE800	3B	870 (650)	640 (480)	800	1250	170M6700 ⁽³⁾
20LE1K1	3B	1275 (955)	935 (695)	1175	900 (2 per phase)	170M6697

(1) Only the Dual Inverter for PowerFlex 700L Frame 3A is available as a DC input inverter.

(2) Two 700A Bussmann 170M6695 fuses per phase can also be used.

(3) Two 630A Bussmann 170M6694 fuses per phase can also be used.

932 Volt DC Input Fusing

Drive Catalog Number	Frame	HP (kW) Rating		DC Input Rating	Bussmann Fuse	
		ND	HD	Amps	Amps	Catalog No.
20LF380	3A	475 (355)	350 (260)	760 ⁽¹⁾	1250	170M6700 ⁽²⁾
20LF705	3B	881 (657)	650 (485)	705	1100	170M6699 ⁽³⁾
20LF1K0	3B	1315 (980)	965 (720)	1050	800 (2 per phase)	170M6696

(1) Only the Dual Inverter for PowerFlex 700L Frame 3A is available as a DC input inverter.

(2) Two 630A Bussmann 170M6694 fuses per phase can also be used.

(3) Two 550A Bussmann 170M6693 fuses per phase can also be used.

Circuit Breakers for Frame 3A/3B Complete Drives

Frame 3A/3B complete drives include an input power circuit breaker. The value of the circuit breaker provided with the drive is listed in the table below.

Frame Size	Input Voltage	Circuit Breaker Provided	Shunt Trip Rating
3A	400...480V AC	800 A	65 kAIC
	575...690V AC	800 A	35 kAIC
3B	400...480V AC	1500 A	100 kAIC
	575...690V AC	1500 A	35 kAIC

Maximum Motor Cable Lengths

See the Wiring and Grounding Guidelines for Pulse Width Modulated (PWM) AC Drives, Installation Instructions, publication [DRIVES-IN001](#), for details on maximum motor cable lengths.

DPI Connections

Frame 2

Drive Connection Points

The PowerFlex 700L frame 2 drive provides a number of cable connection points as shown in the illustration. If an additional external HIM is required for the application, the HIM can be connected to the DPI port on the bottom of the drive. Only one additional external HIM device may be connected. The use of two external HIM devices is not supported. If multiple external HIM devices are required, then install a user-supplied splitter cable or splitter box.

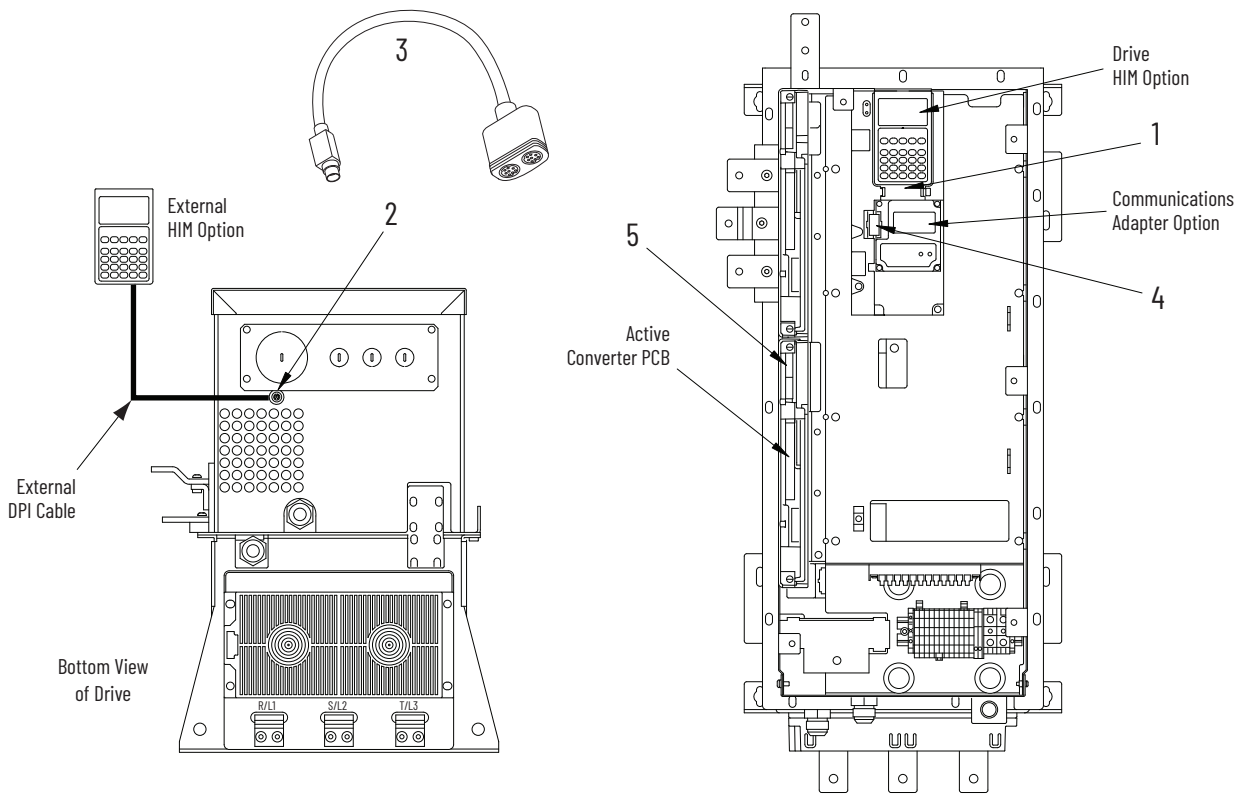

Item	Connector	Description
1	DPI Port 1	HIM connection when installed in the drive.
2	DPI Port 2	Cable connection for handheld and remote options.
3	DPI Port 3 or 2	Splitter cable connection to DPI Port 2 provides additional port.
4	DPI Port 5	Cable connection for communications adapter.
5	DPI Port 6	Internal DPI connection to Active Converter PCB.

External Door-mounted HIM Connection (Optional)

For a frame 2 drive installed in a user-supplied enclosure, an optional external door-mounted HIM may be connected as an alternative to the external HIM option. The cable supplied with the door-mounted HIM option kit connects to the DPI port on the bottom of the drive (see drawing above). For additional installation information, see the instructions provided with the door-mount HIM option kit.

Frame 3A

Drive Connection Points

The PowerFlex 700L provides a number of cable connection points as shown in the drawing below. If an additional external HIM is required for the application, the HIM can be connected to the DPI port on the bottom of the power module. Only one additional external HIM device may be connected. The use of two external HIM devices is not supported. If multiple external HIM devices are required, then install a user-supplied splitter cable or splitter box.

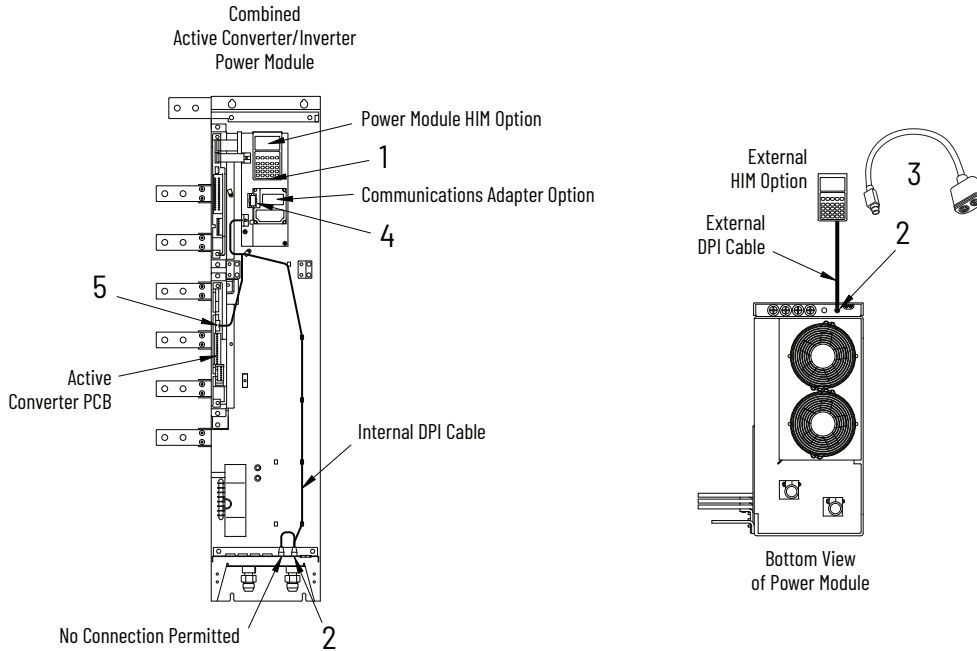

Item	Connector	Description
1	DPI Port 1	HIM connection when installed in power module.
2	DPI Port 2	Cable connection for handheld and remote options.
3	DPI Port 3 or 2	Splitter cable connected to DPI Port 2 provides an additional port.
4	DPI Port 5	Cable connection for communications adapter.
5	DPI Port 6	Internal DPI connection to Active Converter PCB.

External Door-mounted HIM Connection (Optional)

For complete drives, the door-mounted HIM is standard equipment. It is located in the door mount bezel on the door of the power module bay.

Frame 3B

Drive Connection Points

The PowerFlex 700L provides a number of cable connection points as shown in the drawing below. If an additional external HIM is required for the application, the HIM can be connected to the DPI port on the bottom of the power module. Only one additional external HIM device may be connected. The use of two external HIM devices is not supported. If multiple external HIM devices are required, then install a user-supplied splitter cable or splitter box.

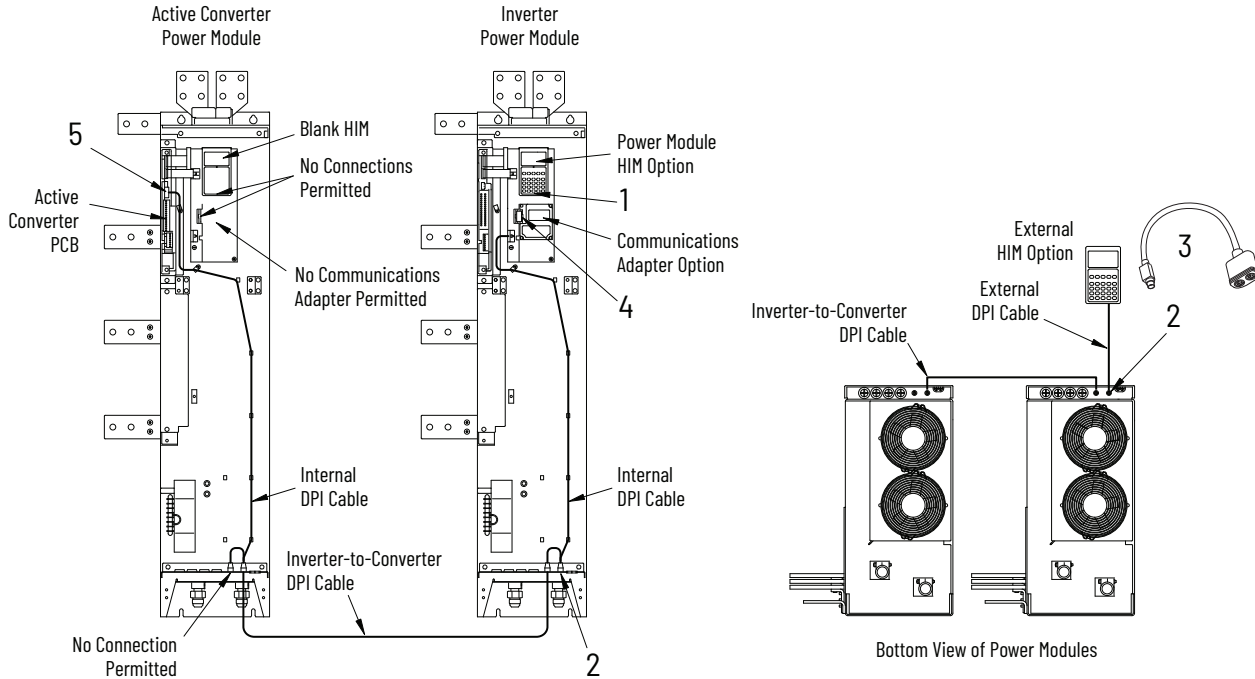

Item	Connector	Description
1	DPI Port 1	HIM connection when installed in power module.
2	DPI Port 2	Cable connection for handheld and remote options.
3	DPI Port 3 or 2	Splitter cable connected to DPI Port 2 provides an additional port.
4	DPI Port 5	Cable connection for communications adapter.
5	DPI Port 6	Internal DPI connection to Active Converter PCB.

External Door-mounted HIM Connection (Optional)

For complete drives, the door-mounted HIM is standard equipment. It is located in the door mount bezel on the door of the power module bay.

Control Connections

Frame 2

Frame 2 Control Terminal Locations

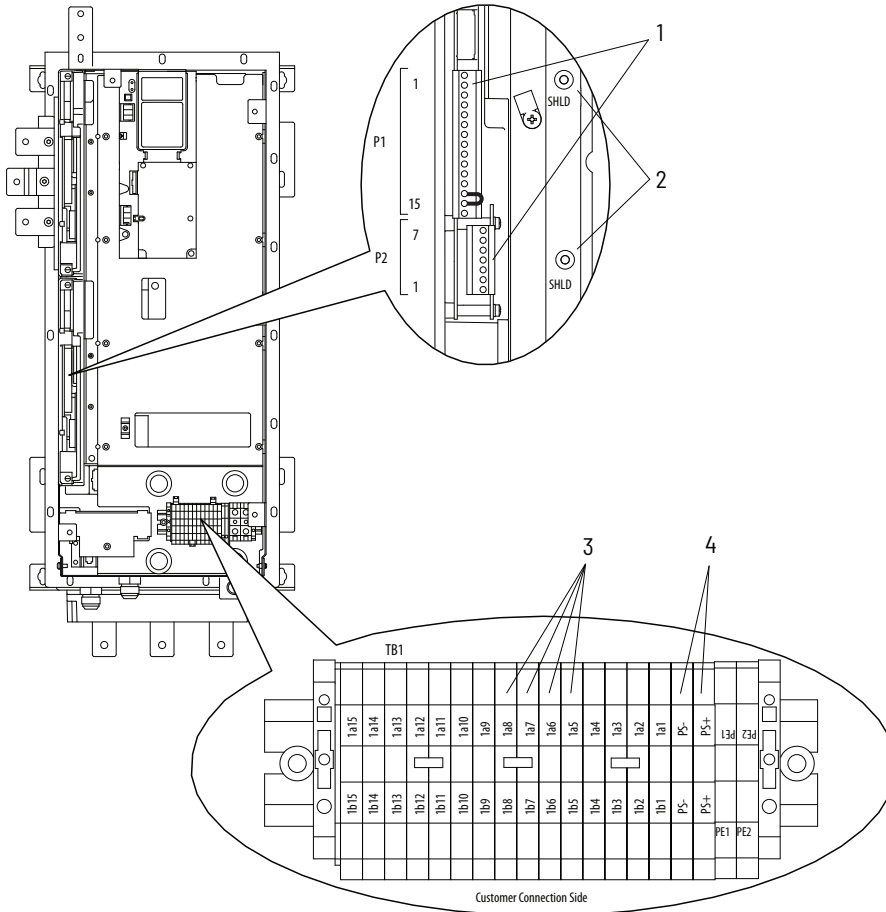

Frame 2 Control Terminal Specifications

Item	Name	Description	Wire Size Range ⁽¹⁾		Recommended Tightening Torque (±10%)	Wire Strip Length
			Maximum	Minimum		
1	PowerFlex 700 Vector Control or PowerFlex 700S Phase II Control Cassette Terminal Blocks	See PowerFlex 700 Series B Technical Data, publication 20B-TD001 or PowerFlex 700S Technical Data, publication 20D-TD002 respectively for details.				
2	Active Converter Cassette Terminal Blocks – P1 & P2	Active Converter AC power and control wiring	3.3 mm ² (#12 AWG)	0.3 mm ² (#22 AWG)	0.8 N•m (7 lb•in)	8 mm (0.31 in.)
3	SHLD Terminal	Terminating point for control wiring shields on the drive	2.1 mm ² (#14 AWG)	0.3 mm ² (#22 AWG)	1.4 N•m (12 lb•in)	10 mm (0.39 in.)
4	Terminal Block – TB1 1b 5: +12/+24V Cooling Loop 1b 6: Cooling Loop Return	Drive control wiring: Output dry contact (12V DC/24V DC, 2 Amps max.) indicating the drive is powered and has completed precharge.	4.0 mm ² (#10 AWG)	0.2 mm ² (#24 AWG)	0.9 N•m (8 lb•in)	8 mm (0.31 in.)
	1b 7: +24V (digin)	Drive-supplied +24V DC				
	1b 8: Gate Enable	Enables the firing of the IGBTs. Factory-installed jumper from terminal 1b 7 to terminal 1b 8 allows firing of the IGBTs.				
5	PS- Terminal PS+ Terminal	300V DC Auxiliary Control voltage	4.0 mm ² (#12 AWG)	0.5 mm ² (#22 AWG)	0.6 N•m (5.3 lb•in)	10 mm (0.39 in.)

(1) Maximum/minimum sizes that the terminals will accept - these are not recommendations.

Frame 3

Frame 3A Control Terminal Locations

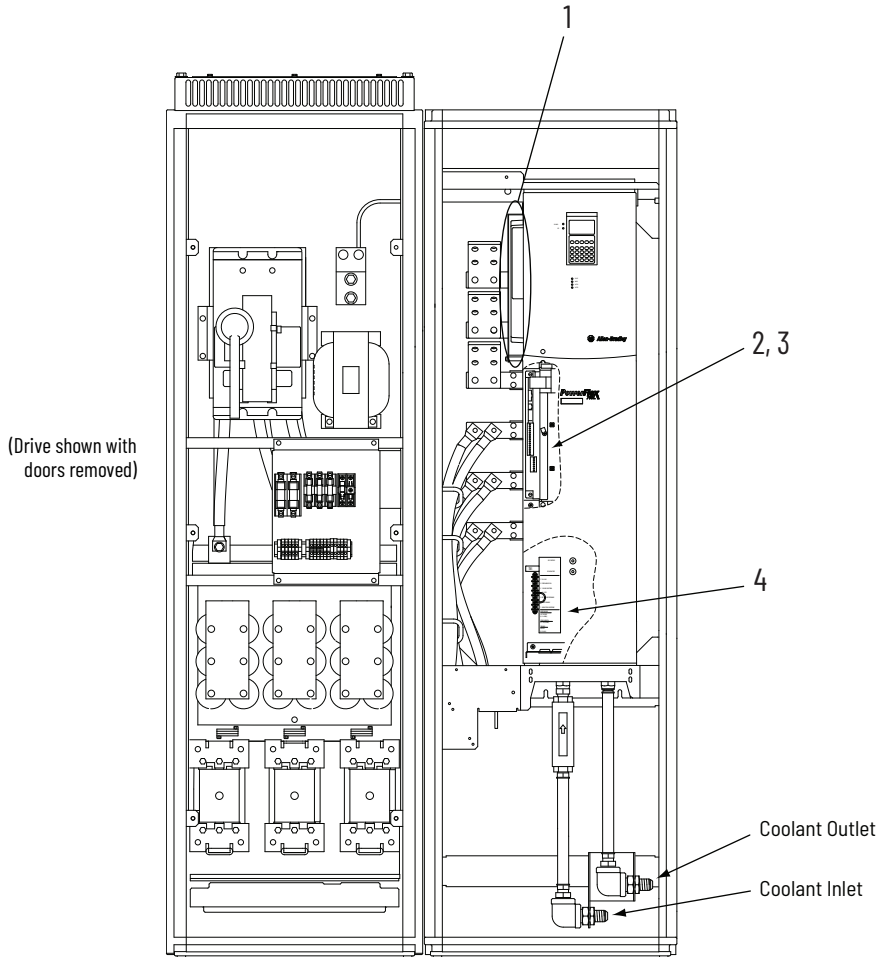

Frame 3B Control Terminal Locations

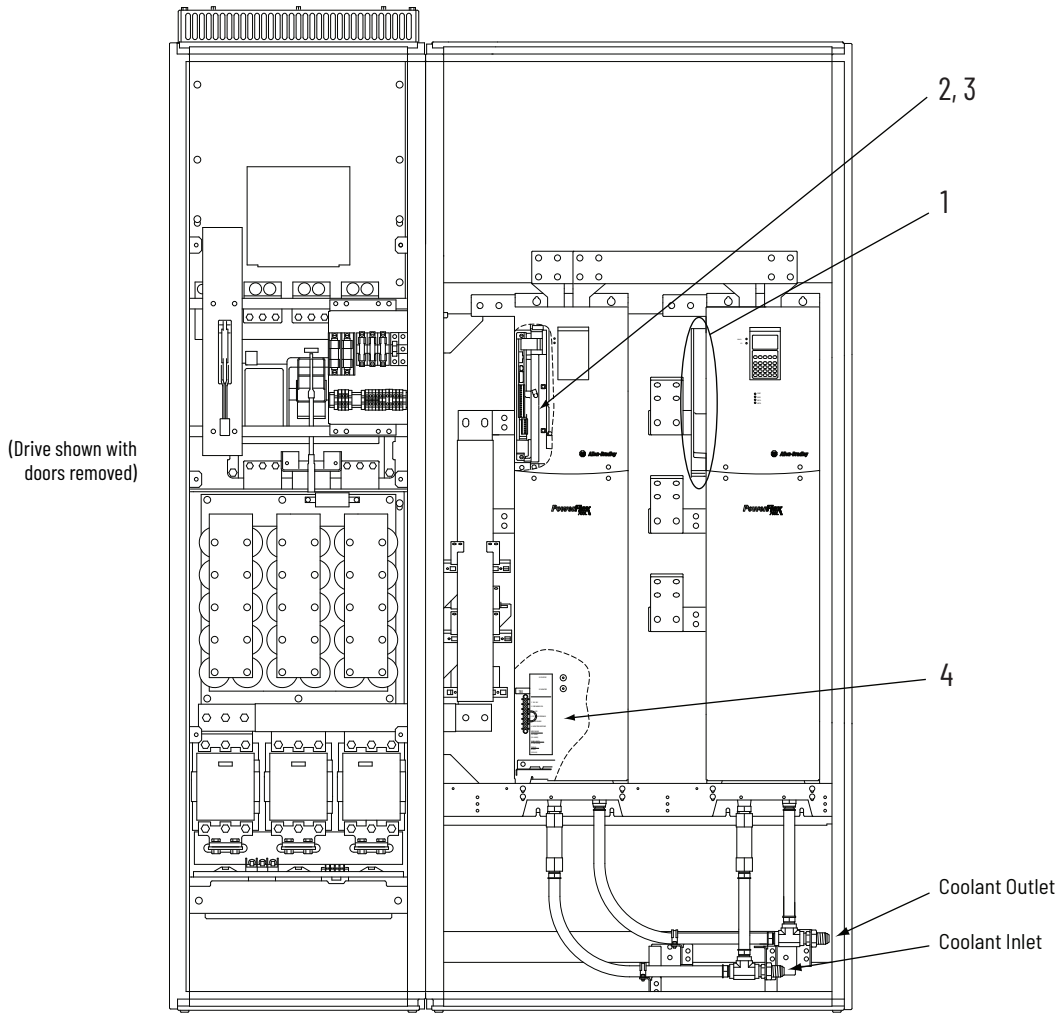







Frame 3A/3B Control Terminal Specifications

Item	Name	Description	Wire Size Range ⁽¹⁾		Recommended Tightening Torque (±10%)	Wire Strip Length	Wire Terminal
			Maximum	Minimum			
1	PowerFlex 700 Vector Control or PowerFlex 700S Phase II Control Cassette Terminal Blocks	See PowerFlex 700 Series B Technical Data, publication 20B-TD001 or PowerFlex 700S Technical Data, publication 20D-TD002 respectively for details.					
2	Active Converter Cassette Terminal Blocks – P1 & P2	Active Converter AC power and control wiring	3.3 mm ² (#12 AWG)	0.3 mm ² (#22 AWG)	0.8 N•m (7 lb•in)	8 mm (0.31 in.)	not applicable
3	SHLD Terminal	Terminating point for control wiring shields on power module	2.1 mm ² (#14 AWG)	0.3 mm ² (#22 AWG)	1.4 N•m (12 lb•in)	10 mm (0.39 in.)	not applicable
4	Terminal Blocks – TB5 and TB6	Power module control wiring	4.0 mm ² (#10 AWG)	0.2 mm ² (#24 AWG)	1.4 N•m (12 lb•in)	8 mm (0.31 in.)	not applicable

(1) Maximum/minimum sizes that the terminals will accept - these are not recommendations.





Control Highlights







Active Converter Control



File	Group	Parameters			
	Current	Rated Amps001	Input Current T004	Reactive Current007	
		Input Current R002	Ground Current005	I Imbalance008	
		Input Current S003	Active Current006	IT Overload009	
	Voltage	Rated Volts010	Input Voltage ST012	DcLink Voltage014	V Imbalance016
		Input Voltage RS011	Input Voltage TR013	DcLink Ripple015	
Power & Time	Rated Power020	Regen kWh023	Life Run Time026		
	AC Line kW021	Lifetime kWh024	Life Power Time027		
	Motoring kWh022	Elapsed Run Time025	Life Pwr Cycles028		
Temperature	Ambient Temp030	IGBT Base Temp031	IGBT Junct Temp032		
Frequency	Line Frequency040	Max Line Freq042	Change Line Freq044		
	Min Line Freq041	Min Max Persist043			
	Start/Stop	Start Config050	Option Select051	Manual Control052	Turn Off Delay053
	Setpoints	DcLink Reference060	Extern Cml Ref062	Modulation Freq064	
		kVAR Reference061	Modulation Index063		
Data Exchange	Converter Control070	Converter Status071	Converter Min Vdc072	Converter Fault073	
	Current	Active I Lmt100	Reactive RateLmt102	I Imbalance Time104	
		Active OL I Lmt101	I Imbalance Lmt103	Regen I Lmt105	
	AC Line Voltage	Ride Through Ena110	Low Vac Lmt112	High Vac Lmt114	V Imbalance Lmt116
		Ride Through Sec111	Low Vac Time113	High Vac Time115	V Imbalance Time117
	Temperature	Ambnt Temp Alrm120	Base Temp Alrm122	Junct Temp Alrm124	CldPlt Temp Alrm126
Ambnt Temp Trip121		Base Temp Trip123	Junct Temp Trip125		
Frequency	PWM Frequency130	AC Low Freq Time132	AC High Freq Time134		
	AC Low Freq Lmt131	AC High Freq Lmt133	AC Maximum dF/dt135		
	Current Loop	Reduce Ilmt Sel150	CML Bandwidth153	CML Kp156	
		Active I Cmd151	CML Damping154	PF Bandwidth157	Reactive I Cmd159
		Inductance152	CML Ki155	Reactive I Lmt158	
Voltage Loop	Voltage Loop Sel160	VML Bandwidth163	VML Kp166	Parallel Config169	
	DcLink Command161	VML Damping164	VML Kf167	Bus Capacitance170	
	Capacitance162	VML Ki165	VML Reset Level168		
	Drive Memory	Param Access Lvl196	Reset Meters200	Drive Checksum203	Password205
		Reset to Defaults197	Language201	Control SW Ver204	
	Diagnostics	Alarm Status211	Fault Amps T223	Fault VoltsTR228	
Start Inhibit214		Fault Amps Q224	Fault Volts Vdc229	Testpoint 2 Sel236	
Fault Frequency220		Fault Amps D225	Fault Base Temp230	Testpoint 2 Data237	
Fault Amps R221		Fault Volts RS226	Testpoint 1 Sel234		
	Fault Amps S222	Fault Volts ST227	Testpoint 1 Data235		
Fault Queue	Fault Config238	Fault 1 Code243	Fault 2 Time246	Fault 4 Code249	
	Fault Clear239	Fault 1 Time244	Fault 3 Code247	Fault 4 Time250	
	Power Up Marker242	Fault 2 Code245	Fault 3 Time248	Alarm Config260	
	Datalinks	Data In A1300	Data In C1304	Data Out A1310	Data Out C1314
		Data In A2301	Data In C2305	Data Out A2311	Data Out C2315
		Data In B1302	Data In D1306	Data Out B1312	Data Out D1316
		Data In B2303	Data In D2307	Data Out B2313	Data Out D2317
	DPI Status	Connect Status320	CS Msg Tx Cnt323	PC Msg Rx Cnt326	
	DPI Error Out321	CS Timeout Cnt324	PC Msg Tx Cnt327	CAN Bus Off Cnt329	
	CS Msg Rx Cnt322	CS Msg Bad Cnt325	PC Timeout Cnt328		
Masks & Owners	Logic Mask340	Fault Clr Mask342	Start Owner344		
	Start Mask341	Stop Owner343	Fault Clr Owner345		
Security	Port Mask Act346	Write Mask Cfg347	Write Mask Act348	Logic Mask Act349	
	Mux'ed Temps	IGBT NTC Temp1330	IGBT NTC Temp4333	IGBT NTC Temp6336	
		IGBT NTC Temp2331	Coldplate Temp1334	IGBT NTC Temp7337	Coldplate Temp2339
		IGBT NTC Temp3332	IGBT NTC Temp5335	IGBT NTC Temp8338	
Digital Inputs	Dig In Status350	Dig In Frc Mask351	Dig In Frc Data352		
Digital Outputs	Dig Out Status360	Dig Out Frc Mask361	Dig Out Frc Data362		

PowerFlex 700 Vector Control

Parameter 196 [Param Access Lvl] set to option 1(Advanced).

File	Group	Parameters			
	Metering	Output Freq001	Output Current003	Elapsed MWh009	Analog In2 Value017
		Commanded Speed002	Torque Current004	Elapsed Run Time010	
	Drive Data	Ramped Speed022	Flux Current005	MOP Reference011	PTC HW Value018
		Speed Reference023	Output Voltage006	DC Bus Voltage012	Spd Fdbk No Filt021
		Commanded Torque**024	Output Power007	DC Bus Memory013	
		Speed Feedback025	Output Powr Fctr008	Analog In1 Value016	
		Rated kW026	Rated Volts027	Rated Amps028	Control SW Ver029
	Motor Data	Motor Type040	Motor NP Hertz043	Mtr NP Pwr Units046	Motor OL Mode ^{6.x} 050
		Motor NP Volts041	Motor NP RPM044	Motor OL Hertz047	
	Torq Attributes	Motor NP FLA042	Motor NP Power045	Motor OL Factor048	Neg Torque Limit**437
		Motor Cntl Sel053	IR Voltage Drop062	Torque Ref A Div**430	
		Maximum Voltage054	Flux Current Ref063	Torque Ref B Sel**431	Mtr Tor Cur Ref**441
		Maximum Freq055	IXo Voltage Drop064	Torque Ref B Hi**432	
		Compensation056	Autotune Torque**066	Torque Ref B Lo**433	
		Flux Up Mode057	Inertia Autotune**067	Torq Ref B Mult**434	
		Flux Up Time058	Torque Ref A Sel**427	Torque Setpoint 1**435	
		SV Boost Filter059	Torque Ref A Hi**428	Torque Setpoint 2**438	
		Autotune061	Torque Ref A Lo**429	Pos Torque Limit**436	
	Volts per Hertz	Start/Acc Boost069	Run Boost*070	Break Voltage*071	Break Frequency*072
	Speed Feedback	Motor Fdbk Type412	Encoder Speed415	Notch Filter K**420	Encoder Z Chan423
		Encoder PPR413	Fdbk Filter Sel416	Marker Pulse421	
		Enc Position Fdbk414	Notch Filter Freq**419	Pulse In Scale422	
	Spd Mode & Limits	Speed Units079	Maximum Speed082	Skip Frequency 2*085	Speed/Torque Mod**088
		Feedback Select080	Overspeed Limit083	Skip Frequency 3*086	
		Minimum Speed081	Skip Frequency 1*084	Skip Freq Band*087	
	Speed References	Speed Ref A Sel090	Speed Ref B Sel093	TB Man Ref Sel096	Pulse Input Ref099
		Speed Ref A Hi091	Speed Ref B Hi094	TB Man Ref Hi097	
		Speed Ref A Lo092	Speed Ref B Lo095	TB Man Ref Lo098	
	Discrete Speeds	Jog Speed 1100	Preset Speed 3103	Preset Speed 6106	
		Preset Speed 1101	Preset Speed 4104	Preset Speed 7107	
		Preset Speed 2102	Preset Speed 5105	Jog Speed 2108	
	Speed Trim	Trim In Select117	Trim Hi119	Trim % Setpoint116	
		Trim Out Select118	Trim Lo120		
	Slip Comp	Slip RPM @ FLA121	Slip Comp Gain*122	Slip RPM Meter123	
	Process PI	PI Configuration124	PI Prop Gain130	PI Fdbk Meter136	PI Feedback Lo463
		PI Control125	PI Lower Limit131	PI Error Meter137	
		PI Reference Sel126	PI Upper Limit132	PI Output Meter138	PI Deriv Time459
		PI Setpoint127	PI Preload133	PI Reference Hi460	PI Output Gain464
		PI Feedback Sel128	PI Status134	PI Reference Lo461	
		PI Integral Time129	PI Ref Meter135	PI Feedback Hi462	
	Speed Regulator	Ki Speed Loop**445	Kf Speed Loop**447	Speed Desired BW**449	Speed Loop Meter**451
		Kp Speed Loop**446	Speed Err Filt BW ^{6.x} 448	Total Inertia**450	
	Ramp Rates	Accel Time 1140	Decel Time 1142	S Curve %146	
		Accel Time 2141	Decel Time 2143		
	Load Limits	Current Lmt Sel147	Current Lmt Gain149	PWM Frequency151	Regen Power Limit**153
		Current Lmt Val148	Drive OL Mode150	Droop RPM @ FLA152	
	Stop/Brake Modes	DB While Stopped145	DC Brake Level158	Bus Reg Mode B162	Flux Braking166
		Stop Mode A155	DC Brake Time159	DB Resistor Type163	
		Stop Mode B156	Bus Reg Ki*160	Bus Reg Kp*164	
		DC Brk Lvl Sel157	Bus Reg Mode A161	Bus Reg Kd*165	
	Restart Modes	Start At PowerUp168	Auto Rstrt Tries174	Sleep-Wake Ref179	Sleep Level182
		Flying Start En169	Auto Rstrt Delay175	Wake Level180	Sleep Time183
		Flying StartGain170	Sleep-Wake Mode178	Wake Time181	Powerup Delay167
	Power Loss	Power Loss Mode184	Power Loss Level186	Load Loss Time188	Gnd Warn Level177
		Power Loss Time185	Load Loss Level187	Shear Pin Time189	

File	Group	Parameters			
	Direction Config	Direction Mode190			
	HIM Ref Config	DPI Loss Action173	Save HIM Ref192	Man Ref Preload193	
	MOP Config	Save MOP Ref194	MOP Rate195		
	Drive Memory	Param Access Lvl196 Reset To Defaults197 Load Frm Usr Set198	Save To User Set199 Reset Meters200 Language201	Voltage Class202 Drive Checksum203 Dyn UserSet Cnfg204	Dyn UserSet Sel205 Dyn UserSet Actv206
	Diagnostics	Drive Status 1209 Drive Status 2210 Drive Status 3 ^{6.x} 222 Drive Alarm 1211 Drive Alarm 2212 Speed Ref Source213 Start Inhibits214	Last Stop Source215 Dig In Status216 Dig Out Status217 Drive Temp218 Drive OL Count219 Motor OL Count220 Fault Speed224	Fault Amps225 Fault Bus Volts226 Status 1 @ Fault227 Status 2 @ Fault228 Status 3 @ Fault ^{6.x} 223 Alarm 1 @ Fault229 Alarm 2 @ Fault230	Testpoint 1 Sel234 Testpoint 2 Sel236 Testpoint 1 Data235 Testpoint 2 Data237 Mtr OL Trip Time221
	Faults	Fault Config 1238 Fault Clear240 Fault Clear Mode241 Power Up Marker242 Fault 1 Code243	Fault 1 Time244 Fault 2 Code245 Fault 2 Time246 Fault 3 Code247 Fault 3 Time248	Fault 4 Code249 Fault 4 Time250 Fault 5 Code251 Fault 5 Time252 Fault 6 Code253	Fault 6 Time254 Fault 7 Code255 Fault 7 Time256 Fault 8 Code257 Fault 8 Time258
	Alarms	Alarm Config 1259 Alarm Clear261 Alarm 1 Code262	Alarm 2 Code263 Alarm 3 Code264 Alarm 4 Code265	Alarm 5 Code266 Alarm 6 Code267 Alarm 7 Code268	Alarm 8 Code269
	Scaled Blocks	Scale1 In Value476 Scale1 In Hi477 Scale1 In Lo478 Scale1 Out Hi479 Scale1 Out Lo480 Scale1 Out Value481	Scale2 In Value482 Scale2 In Hi483 Scale2 In Lo484 Scale2 Out Hi485 Scale2 Out Lo486 Scale2 Out Value487	Scale3 In Value488 Scale3 In Hi489 Scale3 In Lo490 Scale3 Out Hi491 Scale3 Out Lo492 Scale3 Out Value493	Scale4 In Value494 Scale4 In Hi495 Scale4 In Lo496 Scale4 Out Hi497 Scale4 Out Lo498 Scale4 Out Value499
	Comm Control	DPI Baud Rate270 Drive Logic Rslt271	Drive Ref Rslt272 Drive Ramp Rslt273	DPI Port Sel274 DPI Port Value275	DPI Ref Select298 DPI Fdbk Select299
	Masks & Owners	Logic Mask276 Start Mask277 Jog Mask278 Direction Mask279 Reference Mask280	Accel Mask281 Decel Mask282 Fault Clr Mask283 MOP Mask284 Local Mask285	Stop Owner288 Start Owner289 Jog Owner290 Direction Owner291 Reference Owner292	Accel Owner293 Decel Owner294 Fault Clr Owner295 MOP Owner296 Local Owner297
	Datalinks	Data In A1300 Data In A2301 Data In B1302 Data In B2303 Data In C1304	Data In C2305 Data In D1306 Data In D2307 Data Out A1310 Data Out A2311	Data Out B1312 Data Out B2313 Data Out C1314 Data Out C2315 Data Out D1316	Data Out D2317 HighRes Ref ^{6.x} 308
	Security	Port Mask Act595 Write Mask Cfg596	Write Mask Act597 Logic Mask276	Logic Mask Act598	
	Analog Inputs	Anlg In Config320 Anlg In Sqr Root321	Analog In1 Hi322 Analog In1 Lo323	Analog In1 Loss324 Analog In2 Hi325	Analog In2 Lo326 Analog In2 Loss327
	Analog Outputs	Anlg Out Config340 Anlg Out Absolut341 Analog Out1 Sel342	Analog Out1 Hi343 Analog Out1 Lo344 Analog Out2 Sel345	Analog Out2 Hi346 Analog Out2 Lo347 Anlg Out1 Scale354	Anlg Out2 Scale355 Anlg1 Out Setpt377 Anlg2 Out Setpt378
	Digital Inputs	Digital In1 Sel361 Digital In2 Sel362	Digital In3 Sel363 Digital In4 Sel364	Digital In5 Sel365 Digital In6 Sel366	DigIn DataLogic ^{6.x} 411
	Digital Outputs	Dig Out Setpt379 Digital Out1 Sel380 Dig Out1 Level381 Dig Out1 OnTime382	Dig Out1 OffTime383 Digital Out2 Sel384 Dig Out2 Level385 Dig Out2 OnTime386	Dig Out2 OffTime387 Digital Out3 Sel388 Dig Out3 Level389 Dig Out3 OnTime390	Dig Out3 OffTime391 Dig Out Invert392 Dig Out Param393 Dig Out Mask394

File	Group	Parameters			
Applications 	Torq Proving	TorqProve Cnfg600 TorqProve Setup601 Spd Dev Band602 SpdBand Integrat603	Brk Release Time604 ZeroSpdFloatTime605 Float Tolerance606 Brk Set Time607	TorqLim SlewRate608 BrkSlip Count609 Brk Alarm Travel610 MicroPos Scale%611	Torq Prove Sts612 Brake Test Torq ^{6.x} 613
	Adjust Voltage	Adj Volt Phase650 Adj Volt Select651 Adj Volt Ref Hi652 Adj Volt Ref Lo653 Adj Volt Preset 1654 Adj Volt Preset 2655	Adj Volt Preset 3656 Adj Volt Preset 4657 Adj Volt Preset 5658 Adj Volt Preset 6659 Adj Volt Preset 7660 Min Adj Voltage661	Adj Volt Command662 MOP Adj VoltRate663 Adj Volt TrimSel669 Adj Volt Trim Hi670 Adj Volt Trim Lo671 Adj Volt Trim %672	Adj Volt AccTime675 Adj Volt DecTime676 Adj Volt S Curve677
	Oil Well Pump	Max Rod Torque631 TorqAlarm Level632 TorqAlarm Action633 TorqAlarm Dwell634 TorqAlarm Timeout635	TorqAlrm TO Act636 PCP Pump Sheave637 PCP Rod Torque638 Min Rod Speed639 Max Rod Speed640	OilWell Pump Sel641 Gearbox Rating642 Gearbox Sheave643 Gearbox Ratio644 Motor Sheave645	Total Gear Ratio646 DB Resistor647 Gearbox Limit648
Pos/Spd Profile 	ProfSetup/Status	Pos/Spd Prof Sts700 Units Traveled701 Home Position ^{6.x} 702	Pos/Spd Prof Cmd705 Encoder Pos Tol707 Counts Per Unit708	Vel Override711 Find Home Speed713 Find Home Ramp714	Pos Reg Filter718 Pos Reg Gain719
	Profile Step 1-16	Step x Type720... Step x Velocity721...	Step x AccelTime722... Step x DecelTime723...	Step x Value724... Step x Dwell725...	Step x Batch726... Step x Next727...

* These parameters will **only** be displayed when parameter 053 [Motor Cntl Sel] is set to option '2' (Custom V/Hz) or '3' (Fan/Pump V/Hz).
 ** These parameters will **only** be displayed when parameter 053 [Motor Cntl Sel] is set to option '4' (FVC Vector).
 6.x Firmware revision 6.002 or later.

PowerFlex 700S Phase II Control

Digital Current Regulator outperforms older style analog regulators in speed, repeatability and drift.

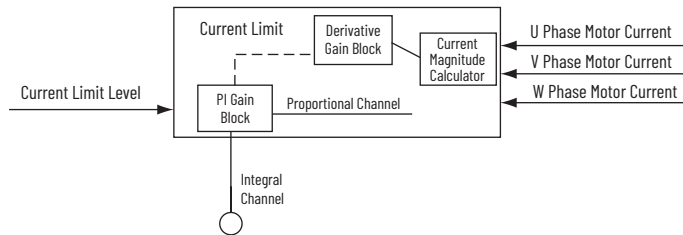

Negative Feed Forward reduces or eliminates overshoot during step speed changes. Helpful in preventing backup during stopping.

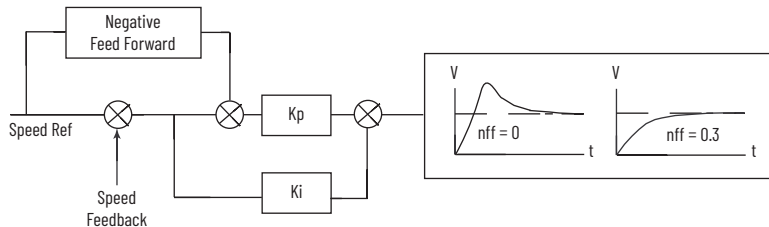

Coarse-to-Fine interpolation for **DriveLogix™ Motion**, direct positioning for precise control and point-to-point for indexing are all features of the **Integral Position Loop**. The loop easily handles applications such as simple indexing and electronic line shaft.

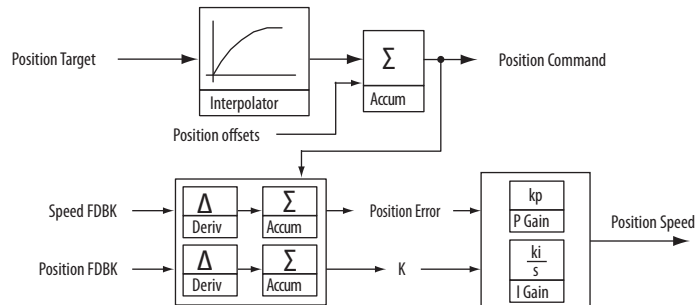

Advanced **Edge-to-Edge Algorithms** and pulse position averaging provides extremely accurate speed measurement and excellent performance at very low speed.

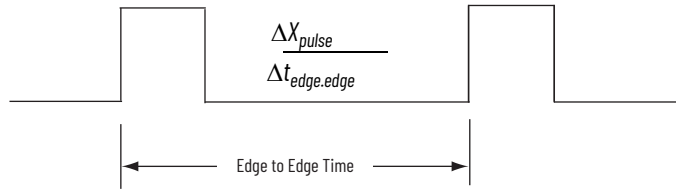

Servo Lock compensates for lost position during step loads to the velocity regulator. Offers optimum performance for draw applications and others.

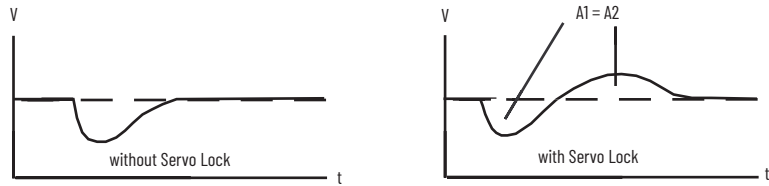

Velocity Response to Step Load

High Speed Analog & Digital I/O execute in 0.5 mSec or less to provide fast response and fast capture for registration information and position data. Output relays, optically isolated and differentially isolated I/O are supplied.

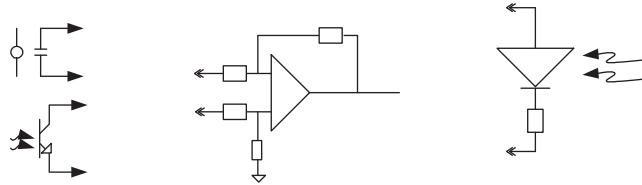

Inertia Adaptation stabilizes inertia disconnect due to gear boxes or flexible couplings. It also provides broadband resonance compensation, allowing up to 4 times improvement to speed regulator bandwidth.

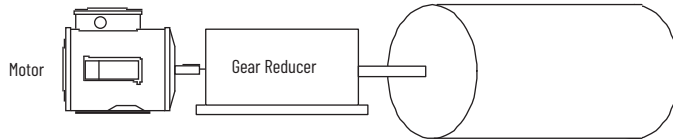

An **Enhanced Process Loop** executes six times faster than previous loops, providing greatly improved dynamic response in tension control applications.

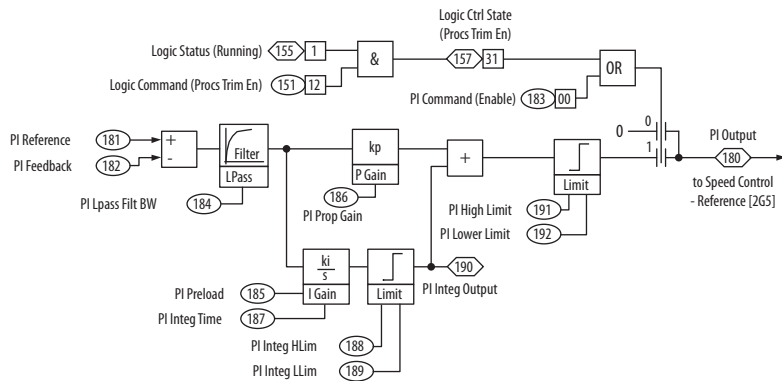

The **Control Loops** within each drive are **Synchronized**. In addition, the control loops for all drives on SynchLink are synchronized within micro-seconds. This provides exceptional link coordination and tracking for critical applications.

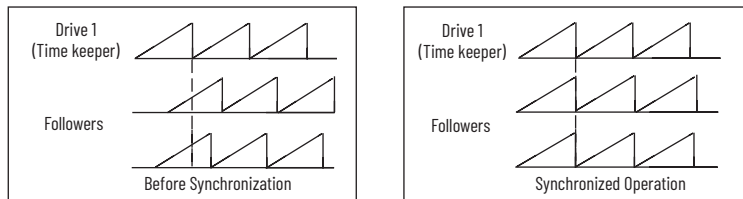

The **Enhanced Bus Regulator** reacts four times faster than previous products, providing quicker stops without over-voltage issues and outstanding performance in other regenerative applications.

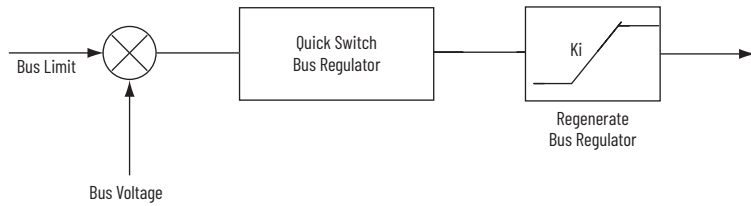

Standard Drive Specifications

Category	Specification	
	Frame 2	Frame 3A/3B
Agency Certification ⁽¹⁾	Listed to UL508C and CAN/CSA-C2.2 No. 14-05. UL Listing for frame 2 is applicable up to 480V AC. UL Listing for frame 3A and 3B is applicable up to 600V AC.	
	Australian Communications and Media Authority In conformity with the following: Radiocommunications Act: 1992 (including Amendments up to 2018) Radiocommunications (Electromagnetic Capability) Standard 2017 Radiocommunications Labeling (Electromagnetic Capability) Notice 2017 Standards applied: EN61800-3	
	These drives are also designed to meet the following specifications: NFPA 70 - US National Electrical Code NEMA ICS 3.1 - Safety standards for Construction and Guide for Selection, Installation and Operation of Adjustable Speed Drive Systems. IEC 146 - International Electrical Code. CMAA Specification #70 (Crane Manufacturers of America Association)	

(1) PowerFlex 700L drives with Safe Torque Off manufactured before 09/25/2020 are TUV certified.

Search PowerFlex Certifications on the Product Certifications website, rok.auto/certifications for a complete list of declarations of conformity, certificates, and other certification details.

Unless otherwise noted, the following specifications pertain to PowerFlex 700L drives equipped with 700 Vector Control or 700S Phase II Control.

Category	Specification	Frame 2		Frame 3A/3B			
		400V	480V	400V	480V	600V	690V
Protection	AC Input Overvoltage Trip:	528V AC	528V AC	528V AC	528V AC	760V AC	760V AC
	AC Input Undervoltage Trip:	340V AC	340V AC	340V AC	340V AC	340V AC	340V AC
	Bus Overvoltage Trip:	815V DC	815V DC	815V DC	815V DC	1168V DC	1168V DC
	Bus Undervoltage Shutoff/ Fault:	305V DC	305V DC	305V DC	305V DC	382V DC	382V DC
	Nominal Bus Voltage:	600V DC	700V DC	600V DC	700V DC	900V DC	1000V DC
	Heat Sink Thermistor:	Monitored by microprocessor overtemp trip					
	Drive Overcurrent Trip	200% of rated current (typical) 220...300% of rated current (dependent on drive rating)					
	Software Overcurrent Trip:						
	Hardware Overcurrent Trip:						
	Line Transients:	Up to 6000 volts peak per IEEE C62.41-1991					
	Control Logic Noise Immunity:	Showering arc transients up to 1500V peak					
	Logic Control Ride-Thru Vector Control:	0.5 seconds minimum, 2 seconds typical					
	700S Phase II Control:	0.25 seconds, drive not running					
	Ground Fault Trip:	Phase-to-ground on drive output					
Short Circuit Trip:	Phase-to-phase on drive output						

Category	Specification	Frame 2	Frame 3A/3B	
Environment	Altitude:	1000 m (3280 ft) at rated current. See Derating Guidelines on page 39 for operation above 1000 m (3280 ft).		
	Maximum Surrounding Air Temperature w/o Derating: IP20, NEMA/UL Type 1:	0...50 °C (32...122 °F)	0...40 °C (32...104 °F)	
	Storage Temperature (all constructions):	-40...85 °C (-40...185 °F)		
	Atmosphere:	Important: Drive must not be installed in an area where the ambient atmosphere contains volatile or corrosive gas, vapors or dust. If the drive is not going to be installed for a period of time, it must be stored in an area where it will not be exposed to a corrosive atmosphere.		
	Relative Humidity:	5...95% non-condensing		
	Shock:	10 g peak for 11 milliseconds duration (± 1.0 ms), three shocks in each direction, in each axis		
	Vibration:	<ul style="list-style-type: none"> • 2 mm (0.07 in.) displacement, 1 g peak amplitude • 1 mm (0.04 in.) displacement from 2...13.2 Hz • 0.7 g acceleration at 13.2 Hz to 1.0 g acceleration at 55 Hz • 1 g acceleration from 55 ...512 Hz Duration: Ten logarithmic sine sweep cycles per axis, at sweep rate of one octave per minute, sequentially performed in each of the three mutually perpendicular axes.		
Electrical	Voltage Tolerance Vector Control:	For full power and operating range, see the PowerFlex 700 Adjustable Frequency AC Drive Technical Data, publication 20B-TD001 .		
	700S Phase II Control:	For full power and operating range, see the PowerFlex 700S Drives with Phase II Control Technical Data, publication 20D-TD002 .		
	Input Frequency Tolerance:	47...63 Hz.		
	Input Phases:	Three-phase input provides full rating for all drives.		
	Displacement Power Factor:	0.98 across entire speed range.		
	Efficiency:	96.2% at rated amps, nominal line volts.	97.5% at rated amps, nominal line volts.	
	Maximum Short Circuit Current Rating:	To match specified circuit breaker capability, less than or equal to 200,000 Amps Symmetrical		
	Actual Short Circuit Rating:	Determined by AIC rating of installed circuit breaker.		
Motor Lead Lengths:	76 m (250 ft) total			

Category	Specification	Frame 2	Frame 3A/3B
Control	Method:	Sine coded PWM with programmable carrier frequency.	
	Carrier Frequency:	2, 4, or 8 kHz. Drive rating based on 4 kHz. See Derating Guidelines on page 39 for more information.	2 or 4 kHz. Drive rating based on 4 kHz.
	Output Voltage Range:	0 to rated motor voltage	
	Output Frequency Range Vector Control:	0...420 Hz	
	700S Phase II Control:	0...350 Hz	
	Frequency Accuracy (Vector Control only) Digital Input: Analog Input:	Within ± 0.01% of set output frequency. Within ± 0.4% of maximum output frequency	
	Frequency Control (Vector Control only):	Speed Regulation - w/Slip Compensation (Volts per Hertz Mode) 0.5% of base speed across 40:1 speed range 40:1 operating range 10 rad/sec bandwidth Speed Regulation - w/Slip Compensation (Sensorless Vector Mode) 0.5% of base speed across 80:1 speed range 80:1 operating range 20 rad/sec bandwidth	
	Speed Control Vector Control:	Speed Regulation - without feedback (Vector Control Mode) 0.1% of base speed across 120:1 speed range 120:1 operating range 50 rad/sec bandwidth Speed Regulation - with feedback (Vector Control Mode) 0.001% of base speed across 120:1 speed range 1000:1 operating range 250 rad/sec bandwidth	
	700S Phase II Control:	Speed Regulation - without feedback 0.1% of base speed across 120:1 speed range 120:1 operating range 50 rad/sec bandwidth Speed Regulation - with feedback 0.001% of base speed across 120:1 speed range 1000:1 operating range 740 rad/sec bandwidth	
	Torque Regulation Vector Control:	Torque regulation without Feedback; ± 5%, 600 rad/sec bandwidth Torque regulation with Feedback; ± 2%, 2500 rad/sec bandwidth	
700S Phase II Control:	Torque regulation without Feedback; ± 10%, 600 rad/sec bandwidth Torque regulation with Feedback; ± 5%, 4400 rad/sec bandwidth		
Selectable Motor Control Vector Control:	Sensorless Vector with full tuning. Standard V/Hz with full custom capability and Vector Control with Force Technology (with and without feedback).		
700S Phase II Control:	Vector Control with Force Technology (with and without feedback), V/Hz Control, and permanent magnet motor control.		

Category	Specification	Frame 2	Frame 3A/3B
Control (continued)	Stop Modes Vector Control:	Multiple programmable stop modes including Ramp, Coast, DC-Brake, Ramp-to-Hold, and S-curve.	
	700S Phase II Control:	Multiple programmable stop modes including Ramp, Coast, and Current Limit.	
	Accel/Decel Vector Control:	Two independently programmable accel and decel times. Each time may be programmed from 0-3600 seconds in 0.1 second increments.	
	700S Phase II Control:	Independently programmable accel and decel times, adjustable from 0-6553.5 seconds in 0.01 second increments.	
	Intermittent Overload:	110% Overload capability for up to 1 minute 150% Overload capability for up to 3 seconds	
	Current Limit Capability Vector Control:	Proactive Current Limit programmable from 20...160% of rated output current. Independently programmable proportional and integral gain.	
	700S Phase II Control:	Independent Motoring and Regenerative Power Limits programmable to 800% of rated output current.	
Electronic Motor Overload Protection:	Class 10 motor overload protection according to NEC article 430 and motor over-temperature protection according to NEC article 430.126 (A)(2). UL File E59272.		
Encoder (Vector Control only)	Type:	Incremental, dual channel	
	Supply:	12V or 5V, 250 mA. 12V or 5V, 10 mA minimum inputs isolated with differential transmitter, 250 kHz maximum.	
	Quadrature:	90°, ± 27° at 25 °C	
	Duty Cycle:	50%, ± 10%	
	Requirements:	Encoders must be line driver type, quadrature (dual channel) or pulse (single channel), 8...15V DC output (3.5...6V DC for 5V encoder), single-ended or differential, and capable of supplying a minimum of 10 mA per channel. Maximum input frequency is 250 kHz. The Encoder Interface Board accepts 12V DC or 5V DC square-wave with a minimum high state of 7.0V DC (12 volt encoder) or 3.1V DC (5 volt encoder). Maximum low state voltage is 0.4V DC.	
Feedback (700S Phase II Control only)	Encoder Input:	Dual Channel Plus Marker, Isolated with differential transmitter Output (Line Drive) Incremental, Dual Channel	
	Encoder Voltage Supply: Maximum Input Freq:	Quadrature type 5V DC or 12V DC (5V DC requires an external power supply), 320 mA/channel 400 kHz	
	Stegmann Hi-Resolution Option Encoder Voltage Supply: Hi-Resolution Feedback: Maximum Cable Length: RS-485 Interface:	11.5V DC @ 130 mA Sine/Cosine 1V P-P Offset 2.5 182 m (600 ft) Hi-Resolution Feedback Option card obtains the following information via the Hiperface RS-485 interface shortly after power-up: Address, Command Number, Mode, Number of Turns, Number of Sine/Cos cycles, and Checksum.	
	Customer-I/O Plug (P1) - Hi Res:	Allen-Bradley PN: S94262912 Weidmuller PN: BL3.50/90/12BK	
	Resolver Option Excitation Frequency: Excitation Voltage: Operating Freq. Range: Resolver Fdbk. Voltage: Maximum Cable Length:	2400 Hz 4.25...26 Vrms 1...10 kHz 2V ± 300mV 304.8 m (1000 ft)	
DriveLogix (700S Phase II Control only)	User Available Memory Base:	1.5 megabytes	
	Battery:	1756-BA1 (Allen-Bradley P/N 94194801) 0.59g lithium	
	Serial Cable:	1761-CBLPM02 to 1761-NET-AIC 1761-CBLPA00 to 1761-NET-AIC 1756-CP3 directly to controller 1747-CP3 directly to controller Category 3 (2)	
	Compact I/O Connection:	Up to (30) modules	
	Cable:	20D-DL2-CL3 20D-DL2-CR3	

Transformer EcoDesign Energy Efficiency Data

The following specifications apply to the transformer that is used in the PowerFlex 700L Liquid-Cooled Adjustable Frequency AC Drive Frames 3A and 3B.

Transformer Kit Catalog Number	Rated Power, (VA)	Primary Voltage	Secondary Voltage	Frequency (Hz)	Core Material and Weight, kg (lb)	Conductor Material and Weight, kg (lb)	Full Load Losses (Watts)	No Load Losses (Watts)	Electrical Power of Any Cooling System Required at No Load (Watts)
SK-L1-XFMR1-F3	1000	380/440/575/690V (50 Hz) 415/480/575/690V (60 Hz)	120/120/120/120V (50 Hz) 130/130/120/120V (60 Hz)	50/60	Steel 8.07 (17.8)	Copper 2.13 (4.7)	76.2	34.1	34.1

Derating Guidelines

Altitude

Above 1000 m (3280 ft), derate the output current by 1% for every 100 additional meters (328 additional feet). This is applicable to filters and power modules. PowerFlex 700L 600/690V drives cannot be used in altitudes above 2000 m (6562 ft) due to voltage spacing requirements.

Ambient

Frame 2 drives have a maximum ambient of 50 °C (122 °F). Frame 3A and 3B drives have a maximum ambient of 40 °C (104 °F). PowerFlex 700L drives cannot be derated to operate at higher temperatures.

Carrier Frequency

For frame 2 drives, see the carrier frequency derating table below. PowerFlex 700L frame 3A and 3B drives cannot be run above 4 kHz.

PowerFlex 700L Frame 2 Drive
Carrier Frequency Derating

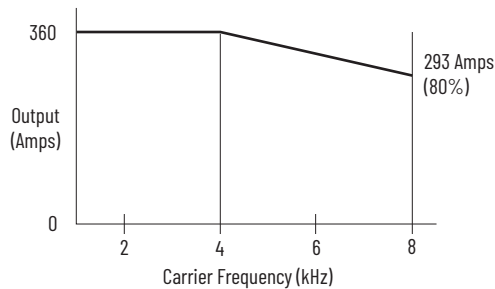

Watts Loss

Watts loss data is shown at Rated Load, Speed, and PWM Carrier Frequency.

Frame Size	Voltage	PWM Freq.	Watts Loss					
			Filter Section	Power Section			Complete Drive	
			Into Air	Into Air	Into Liquid	Total	Total Air	Total Liquid
2	400V	4 kHz	Not Applicable				1500	7900
	480V	4 kHz	Not Applicable				1500	7900
3A	400V	4 kHz	4000	1000	10,500	11,500	5000	10,500
	480V	4 kHz	4000	1000	11,500	12,500	5000	11,500
	600V	4 kHz	4000	1200	10,500	11,700	5200	10,500
	690V	4 kHz	4000	1200	12,000	13,200	5200	12,000
3B ⁽¹⁾	400V	4 kHz	7800	2000	21,000	23,000	9800	21,000
	480V	4 kHz	7800	2000	23,000	25,000	9800	23,000
	600V	4 kHz	7800	2400	21,000	23,400	10,200	21,000
	690V	4 kHz	7800	2400	24,000	26,400	10,200	24,000

(1) Frame 3B power section consists of two power modules. Each module dissipates half (½) of the watts shown in this table.

Cooling Loop Options

This section provides information about the various types of cooling loops.

Liquid-to-Liquid Heat Exchanger

The liquid-to-liquid heat exchanger uses a heat transfer plate to transfer heat from one liquid to another. This method requires a stable water supply from you.

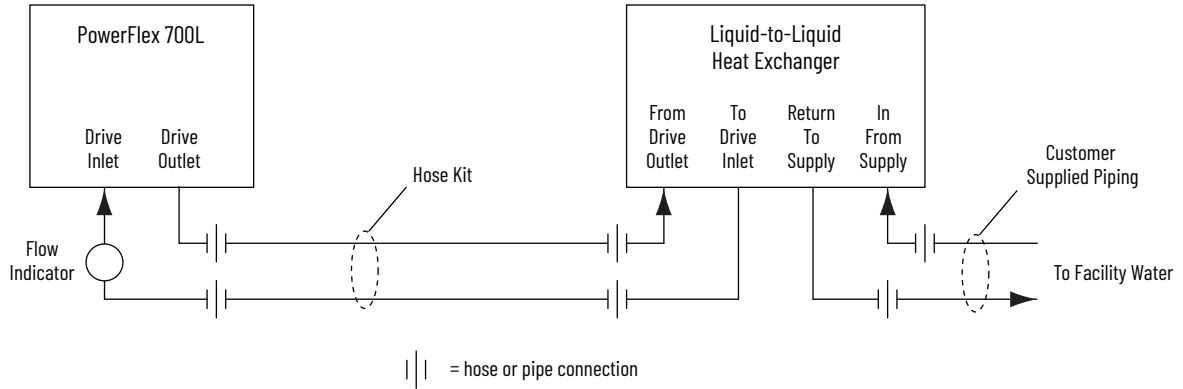

The drawing below shows a cooling loop diagram for a typical liquid-to-liquid heat exchanger.

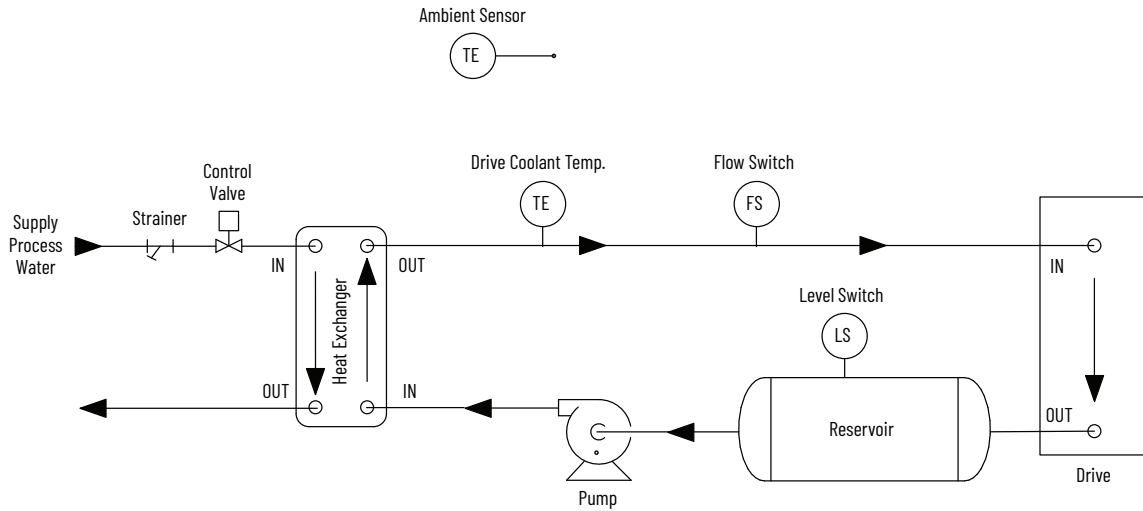

The main components of the liquid-to-liquid heat exchanger cooling loop are listed below.

Part	Description
Strainer	Filters particles from the supply water.
Control Valve	Controls the supply loop water flow.
Heat Exchanger Plate	Transfers heat from the drive loop to the supply loop.
Ambient Sensor	Senses the ambient temperature used for the dew point control.
Drive Coolant Temperature Sensor	Senses the drive coolant temperature used for the dew point control.
Drive Coolant Flow Switch	Measures the drive coolant flow rate.
Level Switch	Senses the level of coolant in the reservoir.
Reservoir	Stores drive coolant.
Pump and Motor	Circulates drive coolant.

Liquid-to-Air Heat Exchanger

The liquid-to-air heat exchanger uses radiator technology to transfer heat from a liquid to surrounding air. This is a simple closed loop system – it does not require a water supply from you. However, this system requires surrounding air 5...10 °C (41...50 °F) below the maximum operating temperature of the drive.

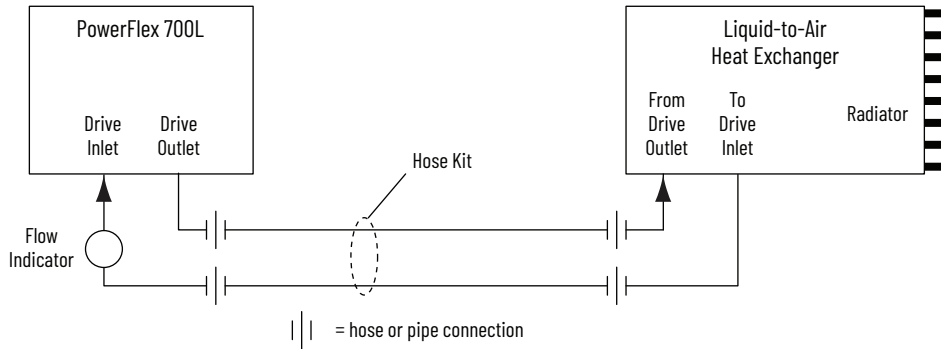

The drawing below shows a cooling loop diagram for a typical liquid-to-air heat exchanger.

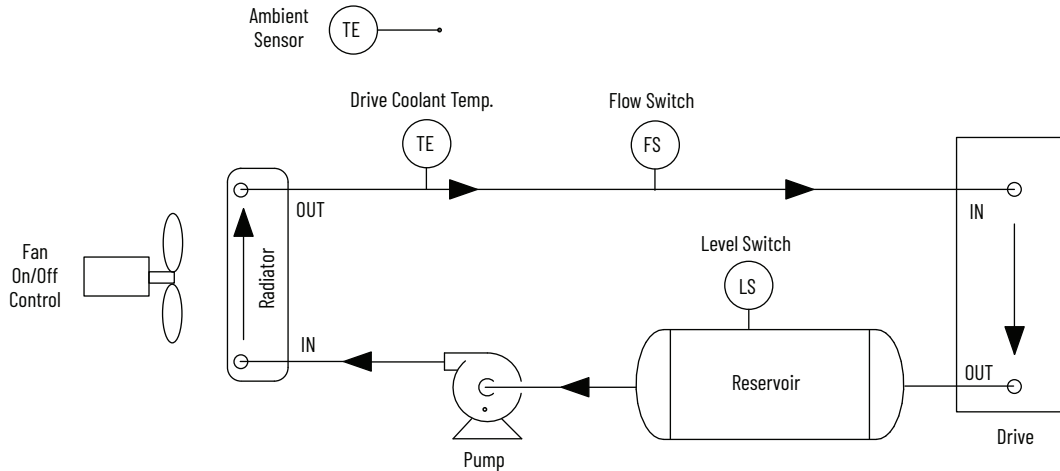

The main components of the liquid-to-air heat exchanger cooling loop are listed below.

Part	Description
Fan	Blows air across the radiator.
Radiator	Transfers heat from liquid to air.
Ambient Sensor	Senses the ambient temperature used for the dew point control.
Drive Coolant Temperature Sensor	Senses the drive coolant temperature used for the dew point control.
Drive Coolant Flow Switch	Measures the drive coolant flow rate.
Level Switch	Senses the level of coolant in the reservoir.
Reservoir	Allows for expansion of coolant.
Pump and Motor	Circulates drive coolant.

Chiller

The chiller uses refrigerant to transfer heat from a liquid to air. This is a simple closed loop system – it does not require a water supply from you. A chiller can achieve almost any coolant temperature required. Coolant temperature should be at or above ambient temperature to avoid condensation on drive components.

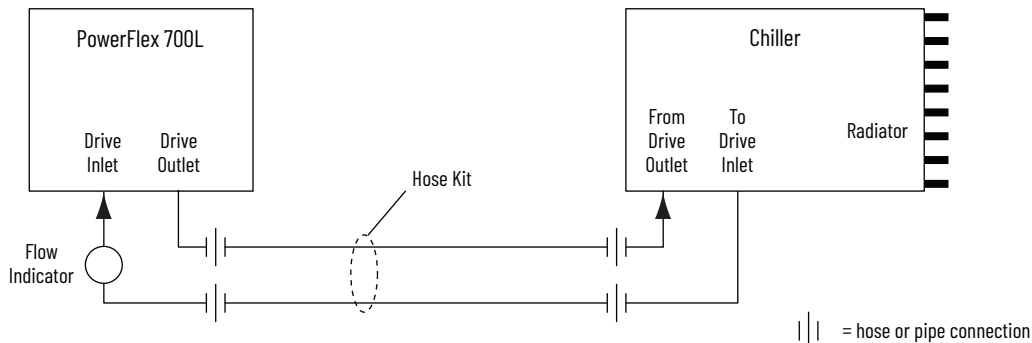

The drawing below shows a cooling loop diagram for a typical chiller.

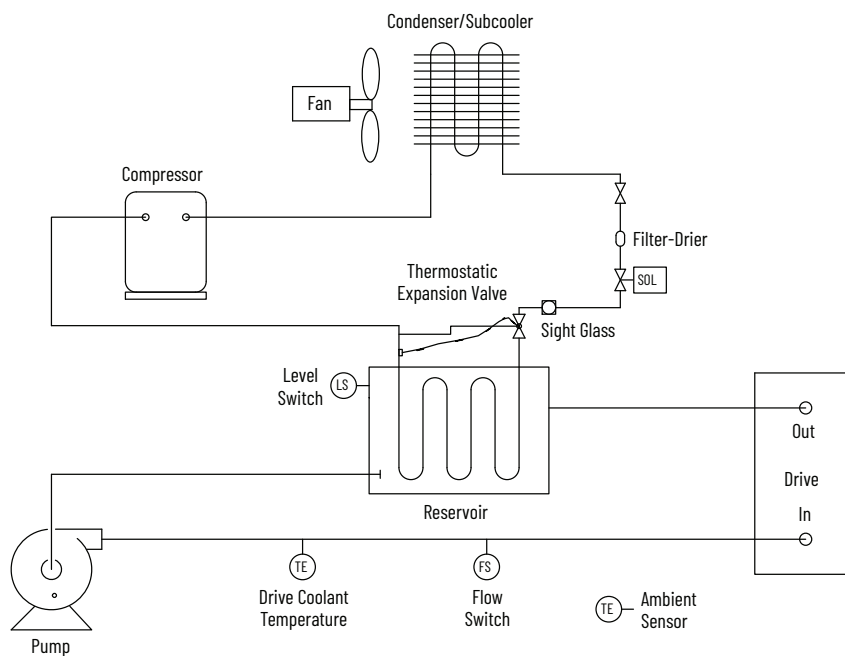

The main components of the chiller cooling loop are listed below.

Part	Description
Compressor	Forces the refrigerant into a smaller space.
Fan	Blows air across the condenser/subcooler.
Condenser/Subcooler	Cools the refrigerant.
Filter-Drier	Filters the refrigerant.
Sight Glass	Allows viewing of the level of drive coolant in the reservoir.
Thermostatic Expansion Valve	Allows for expansion of the refrigerant.
Level Switch	Senses the level of coolant in the reservoir.
Reservoir	Allows for expansion of coolant.
Pump and Motor	Circulates drive coolant.
Drive Coolant Temperature Sensor	Senses the drive coolant temperature used for the dew point control.
Drive Coolant Flow Switch	Measures the drive coolant flow rate.
Ambient Sensor	Senses the ambient temperature used for the dew point control.

Cooling Loop Application Guidelines

Do not use ferrous and plated-ferrous materials for pipe-treated water to the power modules and drive. Use of ferrous materials will degrade the performance of the power module chillplate.

Use the following guidelines for applying cooling loops.

- The allowable drive coolant temperature range is listed below:
 - Frame 2 Drive: 0...50 °C (32...122 °F)
 - Frame 3A/3B Drive: 0...40 °C (32...105 °F)

When using coolant at a temperature below the dew point of the surrounding air, condensation can accumulate on the drive heatsink and/or circuit boards, which can damage the drive. In this situation, install a coolant flow regulating device and tube/hose insulation. A flow regulating device modulates the coolant flow rate to a level that permits the drive heatsink temperature to rise above the dew point. Insulation for customer side tube or hose can be closed-cell foam insulation with a minimum 12.7 mm (0.50 in.) wall thickness.

- Include a flow switch in the cooling loop on the connection to the drive inlet to turn off the drive if coolant flow drops below the minimum flow required by the drive (see [Drive Coolant Requirements](#)).
- Circulate coolant through the drive only when the drive is also powered. Failure to do this can result in condensation accumulating on the drive heatsink and/or circuit boards, which could damage the drive.
- Use an interlock from the cooling loop to stop the drive when the cooling loop is faulted.
- For applications requiring a closed loop coolant system, vent the system to remove air that can otherwise degrade the performance of the drive heatsink.
- Install a flow measuring device at the inlet of each converter and each inverter power module. Note that flow measuring devices are included in the PowerFlex 700L frame 3A and 3B complete drive cabinets (13th position in catalog number = A). The coolant flow rate (GPM) must meet the requirements in the Coolant Requirements for one Frame 2, 3A, or 3B Drive table in [Drive Coolant Requirements](#).
- We recommend the following types of pipe for cooling loop connections:
 - Copper tubing, type L
 - Brass pipe
 - Stainless steel, 300 series

IMPORTANT Do not use galvanized pipe.

- Provide a method in the cooling loop for draining and replacing the coolant.

Drive Coolant Connections

Frame 2 Drive or Frame 3A or 3B Power Module

Coolant connections for frame 2 drives and frame 3A and 3B power modules are made using 37 degree flare fittings which have a:

- 3/4-inch nominal size
- '12' SAE dash size
- 1-1/16-12 UN/UNF-2B external thread size

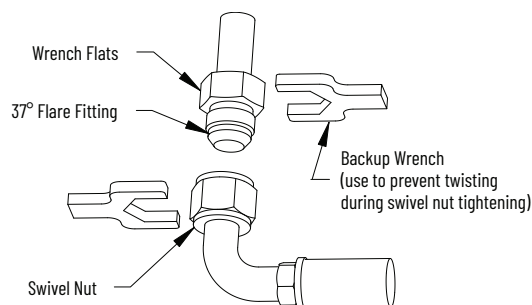

Frame 3A/3B Complete Drive

Frame 3A/3B Complete Drive coolant connections are made using 37 degree flare fittings which have a:

- 1-inch nominal size
- ‘-16’ SAE dash size
- 1-5/16-12 UN/UNF-2B external thread size

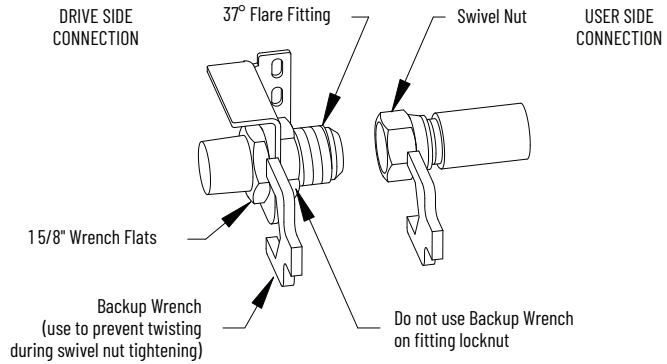
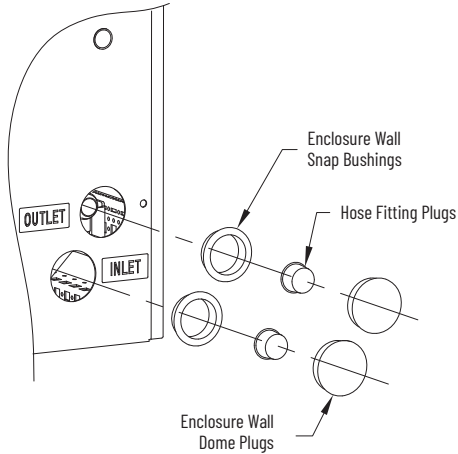

Drive Cooling Loop Hose Kits

Depending on the location of the heat exchanger or chiller relative to the drive, the following drive cooling loop hose kits are available.

Hose Length	Hoses in Kit	Drive Side ⁽¹⁾ Coupling Size	Heat Exchanger Side Coupling Size	Used With	Hose Kit ⁽²⁾ Catalog Number
3 m (10 ft)	2	0.75 inch	0.75 inch	Frame 2	20L-GH10-B1
9.1 m (30 ft)	2	0.75 inch	0.75 inch	Frame 2	20L-GH30-B1
3 m (10 ft)	2	1 inch	1 inch with 90° elbow	Frame 3A	20L-GH10-A2
9.1 m (30 ft)	2	1 inch	1 inch with 90° elbow	Frame 3A	20L-GH30-A2
3 m (10 ft)	2	1 inch	1 inch	Frame 3B	20L-GH10-A1
9.1 m (30 ft)	2	1 inch	1 inch	Frame 3B	20L-GH30-A1

(1) All drive side hose kit fittings are 37 degree flare.
 (2) Each hose kit contains two (2) hoses and the appropriate connectors.

Drive Coolant Requirements

IMPORTANT Since coolant performance slowly degrades over time, we recommend replacing the drive loop coolant every two years and whenever the loop is drained for servicing.

For the drive coolant, we recommend that you use a 50/50 pre-mix of either ethylene or propylene glycol and water with a corrosion inhibitor for the wet drive loop materials. The levels of corrosion inhibitor need to be maintained according to the manufacturer’s instructions.

If a pre-mix is not used, the drive coolant must be 50/50 mix of ethylene or propylene glycol mix to **distilled** water with an appropriate corrosion inhibitor for the wet drive loop materials. **Deionized water is prohibited.** The water must have less than 50 ppm concentrations of these chemical compounds:

- Sulfate and chloride
- Hard water ions such as Mg⁺⁺ and Ca⁺⁺

Use of common silicate-containing, automotive-type ethylene glycol solutions are prohibited as they can damage the heat exchanger and drive and cooling module equipment.

The pH level, maintenance interval, and adjustment level must be followed according to the coolant and inhibitor manufacturer’s recommendation. A pH level outside the range of 4...8 can cause significant damage to wetted aluminum surfaces.

Regardless of whether you use pre-mixed or not, the drive coolant and corrosion inhibitor must be compatible with the following materials:

- Copper
- Brass
- Aluminum
- Arimid fiber gasket with nitrile binder (Garlock, Inc. Blue-Gard 3000[®] gasket)
- Synthetic rubber hose (Parker Hannifan Corp 801 General Purpose Hose)
- Viton seal (only Complete Drive)

Biocide

A biocide may be needed to control biological growth. Use of a biocide is permitted. For specific recommendations, consult a reputable water treatment company.

IMPORTANT Do not mix different brands or types of coolants. The coolant, corrosion inhibitor, and any biocide used must be compatible.

Coolant Requirements for One Frame 2, 3A or 3B Drive

Drive Frame Size	Coolant Temperature Range	Minimum Coolant Flow Rate	Maximum Coolant Flow Rate	Pressure Drop ⁽¹⁾ From Drive Inlet to Drive Outlet at Minimum Coolant Flow Rate	Coolant Type
2	0...50 °C (32...122 °F)	30.3 LPM (8 gpm)	45.4 LPM (12 gpm)	1.58 bar (23 psi)	WEG50 ⁽²⁾ or WPG50 ⁽³⁾
3A	0...40 °C (32...104 °F)	30.3 LPM (8 gpm)	45.4 LPM (12 gpm)	0.35 bar (5 psi)	
3B	0...40 °C (32...104 °F)	56.8 LPM (15 gpm) ⁽⁴⁾	94.6 LPM (25 gpm)	0.48 bar (7 psi) ⁽⁴⁾	

- (1) Pressure drop does not include any system connections such as hoses or piping. Cooling systems must be sized to provide minimum flow considering entire system pressure drop.
- (2) WEG50 equals good quality or distilled water with approved **inhibited*** ethylene glycol, 50% glycol by volume.
- (3) WPG50 equals good quality or distilled water with approved **inhibited*** propylene glycol, 50% glycol by volume.
- (4) Frame 3B includes separate converter and inverter power modules. A single inverter or converter power module requires a minimum flow rate of 30.3 LPM (8 gpm) at 0.35 bar (5 psi).

* Inhibited ethylene glycol or propylene glycol must contain a corrosion inhibitor compatible with the cooling loop material listed on [page 45](#).

Estimated Coolant Amount for the Drive Loop

Drive Frame Size	Estimated Amount of Coolant ⁽¹⁾
2	15.1 liters (4 gal)
3A	19 liters (5 gal)
3B	19 liters (5 gal)

- (1) The estimated amount of coolant is based on the heat exchanger using 1.2 m (4 ft) hoses. Longer hoses require more coolant. The maximum hose length of 9.1 m (30 ft) would require up to an additional 2.8 liters (0.75 gal).

Additional Resources

These documents contain additional information concerning related products from Rockwell Automation. You can view or download publications at rok.auto/literature.

Resource	Description
PowerFlex 700L Liquid-cooled Adjustable Frequency AC Drive User Manual, publication 20L-UM001	This manual provides the basic information needed to install, start-up, and troubleshoot the PowerFlex 700L Liquid-cooled AC drive.
PowerFlex 700L Active Converter Power Module User Manual, publication PFLEX-UM002	The purpose of this manual is to provide you with the basic information needed to wire and operate the PowerFlex 700 Active Converter Power Module.
PowerFlex 700 AC Drives - Frames 0...10 User Manual, Vector Control Firmware 4.001 and Up, publication 20B-UM002	The purpose of this manual is to provide you with the basic information needed to program and troubleshoot the PowerFlex 700 Adjustable Frequency AC Drive with Vector Control.
PowerFlex 700S High Performance AC Drive - Phase II Control Programming Manual, publication 20D-PM001	The purpose of this manual is to provide you with the information needed to start-up, program and troubleshoot PowerFlex 700S Phase II Adjustable Frequency AC drives.
DriveGuard Safe Torque Off Option for PowerFlex 700S Phase II and 700L Drives User Manual, publication 20D-UM007	The purpose of this manual is to explain The DriveGuard Safe Torque Off option, and how it can help provide protection to meet the requirements for SIL CL2 and Category 3 or PL d class applications.
PowerFlex 70/700 Adjustable Frequency AC Drives Reference Manual, publication PFLEX-RM001	The purpose of this manual is to provide detailed drive information including operation, parameter descriptions and programming.
PowerFlex 700L Liquid-to-Liquid Heat Exchanger User Manual, publication 20L-UM002	The purpose of this manual is to provide you with the installation and operating information for the PowerFlex 700L Liquid-to-Liquid Heat Exchanger used with PowerFlex 700L Liquid-cooled drives and power modules.
Industry Installation Guidelines for Pulse Width Modulated (PWM) AC Drives, Application Technique, publication DRIVES-AT003	The purpose of this application technique is to provide basic information for different enclosure systems and environmental/location considerations (to help protect against environmental contaminants), and power and grounding considerations needed to properly install a Pulse Width Modulated (PWM) AC drive.
Wiring and Grounding Guidelines for Pulse Width Modulated (PWM) AC Drives, publication DRIVES-IN001	This manual provides the basic information needed to properly install, protect, wire, and ground pulse width modulated (PWM) AC drives.
Preventive Maintenance of Industrial Control and Drive System Equipment, publication DRIVES-T0001	Provides a checklist that can be used as a guide for performing preventive maintenance of industrial control and drive system equipment.
EtherNet/IP Network Devices User Manual, publication ENET-UM006	Describes how to configure and use EtherNet/IP devices to communicate on the EtherNet/IP network.
Ethernet Reference Manual, publication ENET-RM002	Describes basic Ethernet concepts, infrastructure components, and infrastructure features.
System Security Design Guidelines Reference Manual, publication SECURE-RM001	Provides guidance on how to conduct security assessments, implement Rockwell Automation products in a secure system, harden the control system, manage user access, and dispose of equipment.
UL Standards Listing for Industrial Control Products, publication CMPNTS-SR002	Assists original equipment manufacturers (OEMs) with construction of panels, to help ensure that they conform to the requirements of Underwriters Laboratories.
American Standards, Configurations, and Ratings: Introduction to Motor Circuit Design, publication IC-AT001	Provides an overview of American motor circuit design based on methods that are outlined in the NEC.
Industrial Components Preventive Maintenance, Enclosures, and Contact Ratings Specifications, publication IC-TD002	Provides a quick reference tool for Allen-Bradley industrial automation controls and assemblies.
Safety Guidelines for the Application, Installation, and Maintenance of Solid-state Control, publication SGI-1.1	Designed to harmonize with NEMA Standards Publication No. ICS 1.1-1987 and provides general guidelines for the application, installation, and maintenance of solid-state control in the form of individual devices or packaged assemblies incorporating solid-state components.
Industrial Automation Wiring and Grounding Guidelines, publication 1770-4.1	Provides general guidelines for installing a Rockwell Automation industrial system.
Product Certifications website: rok.auto/certifications	Provides declarations of conformity, certificates, and other certification details.

Rockwell Automation Support

Use these resources to access support information.

Technical Support Center	Find help with how-to videos, FAQs, chat, user forums, Knowledgebase, and product notification updates.	rok.auto/support
Local Technical Support Phone Numbers	Locate the telephone number for your country.	rok.auto/phonesupport
Technical Documentation Center	Quickly access and download technical specifications, installation instructions, and user manuals.	rok.auto/techdocs
Literature Library	Find installation instructions, manuals, brochures, and technical data publications.	rok.auto/literature
Product Compatibility and Download Center (PCDC)	Download firmware, associated files (such as AOP, EDS, and DTM), and access product release notes.	rok.auto/pcdc

Documentation Feedback

Your comments help us serve your documentation needs better. If you have any suggestions on how to improve our content, complete the form at rok.auto/docfeedback.

Allen-Bradley, Connected Components Workbench, ControlFLASH, DPI, DriveExecutive, DriveGuard, DriveLogix, DriveObserver, DriveTools, expanding human possibility, PanelView, PowerFlex, RSLinx, RSLogix, Rockwell Automation, and SCANport are trademarks of Rockwell Automation, Inc.





DeviceNet, ControlNet, and EtherNet/IP are trademarks of ODVA, Inc.

Trademarks not belonging to Rockwell Automation are property of their respective companies.

Rockwell Automation maintains current product environmental compliance information on its website at rok.auto/pec.

Rockwell Automation NV Commercial Registration Number 0424.293.935

Rockwell Otomasyon Ticaret A.Ş. Kar Plaza İş Merkezi E Blok Kat:6 34752, İçerenköy, İstanbul, Tel: +90 (216) 5698400 EEE Yönetmeliğine Uygundur

Connect with us.    

rockwellautomation.com ————— **expanding human possibility®**

AMERICAS: Rockwell Automation, 1201 South Second Street, Milwaukee, WI 53204-2496 USA, Tel: (1) 414.382.2000

EUROPE/MIDDLE EAST/AFRICA: Rockwell Automation NV, Pegasus Park, De Kleetlaan 12a, 1831 Diegem, Belgium, Tel: (32) 2663 0600

ASIA PACIFIC: Rockwell Automation SEA Pte Ltd, 2 Corporation Road, #04-05, Main Lobby, Corporation Place, Singapore 618494, Tel: (65) 6510 6608

UNITED KINGDOM: Rockwell Automation Ltd., Pitfield, Kiln Farm, Milton Keynes, MK11 3DR, United Kingdom, Tel: (44)(1908) 838-800

Publication 20L-TD0011-EN-P - January 2025

Supersedes Publication 20L-TD0011-EN-P - January 2025

Copyright © 2025 Rockwell Automation, Inc. All rights reserved. Printed in the U.S.A.