



120/220V AC Power Supply with User Power

(Cat. No. 1771-PS7 Series C)

Installation Data

To the Installer

Use this publication to install a 1771-PS7 external power supply. You perform these tasks:

- prepare to mount the 1771-PS7
- mount the 1771-PS7 and connect backplane power
- connect user power to modules (optional)
- connect ac power source to the 1771-PS7

Prepare for Installation

The 1771-PS7 provides:

Power:	For:	Output Voltage:
backplane power	1771-I/O chassis	5V dc at 16A (max)
user power	IMC 120, 120AR, 121 and 123 motion controller modules non-IMC products	+5V dc at 8A (max) +15V dc at 2A (max) -15V dc at 2A (max) +24V dc at 2.5A (max)



ATTENTION: To avoid overloading the power supply:

- limit backplane power to 80W, or
- limit user power to 65W, or
- limit total system power (backplane + user) to 100W

To Calculate the Power Requirements for:	See:	Pub. No.
IMC 120 Motion Control System	IMC 120 Motion Control System Installation Manual	1771-6.5.45
IMC 121 Motion Control System	IMC 121 Installation Manual	1771-6.2.4
IMC 123 Motion Control System	IMC 123 Motion Control System Installation Manual	1771-6.2.3

Installation Data

120/220V AC Power Supply with User Power
1771-PS7 Series C

Mount the 1771-PS7 and Connect Backplane Power

Before mounting the 1771-PS7, you should:

- mount the I/O chassis. See the Universal I/O Chassis Installation Data (1771-2.210) for information on mounting the I/O chassis.
- set the power supply configuration jumper. The 1771-PS7 is an external power supply. Set the configuration jumper on the I/O chassis to the N position.

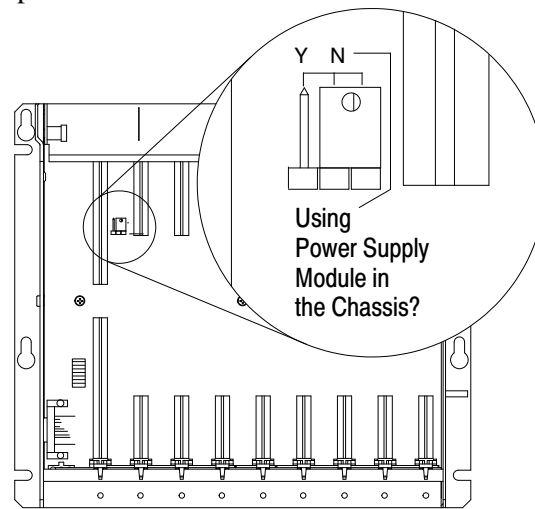

The 1771-PS7 has a D-sub power connector that provides power to the I/O chassis backplane.

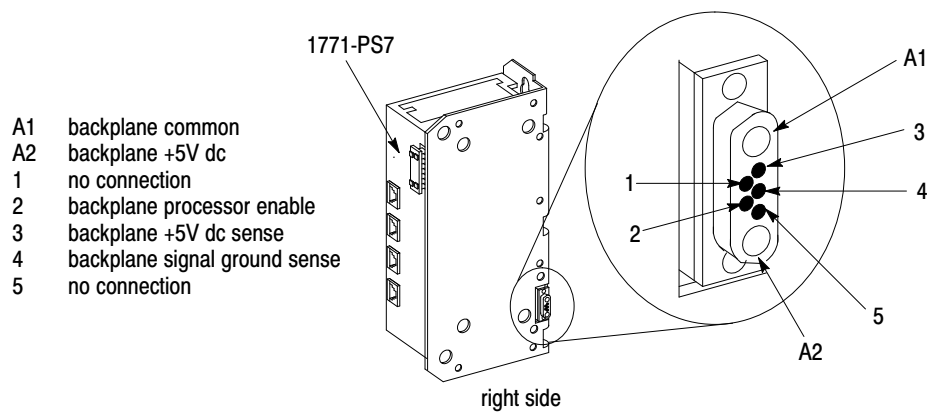

What to Do Next

To Attach the 1771-PS7 to this Chassis:	Go to:
1771-A1B, -A2B, -A3B1, -A4B panel mount	page 3
1771-A3B 19" rack mount	page 6

Installation Data

120/220V AC Power Supply with User Power
1771-PS7 Series C

Attaching to Panel-Mounted I/O Chassis

To attach the 1771-PS7 to a panel-mounted chassis:

1. Remove the four #10-32 nuts and separate the mounting plate from the power supply.

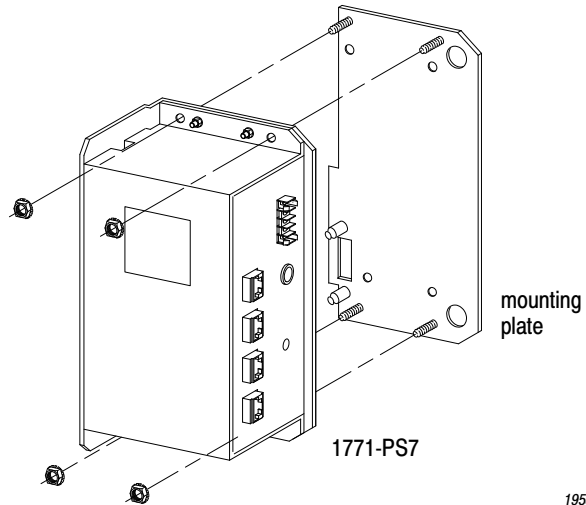

2. Use four 0.312-inch screws (#10-32) and washers to install the mounting plate onto the side plate of the I/O chassis.



ATTENTION: Do not use screws longer than 0.312 inch to mount the 1771-PS7 to the I/O chassis. Longer screws may damage the equipment.

Important: Leave the screws loose to allow the mounting plate to move until alignment procedure is complete.

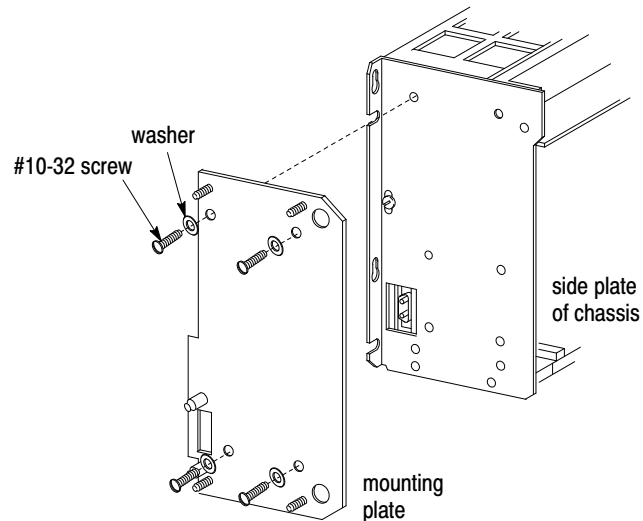

Installation Data

120/220V AC Power Supply with User Power
1771-PS7 Series C

3. Install the supplied alignment fixture onto the taper pins of the mounting plate (moving mounting plate as necessary) and push until the alignment fixture is fully inserted into the receptacle on the chassis.

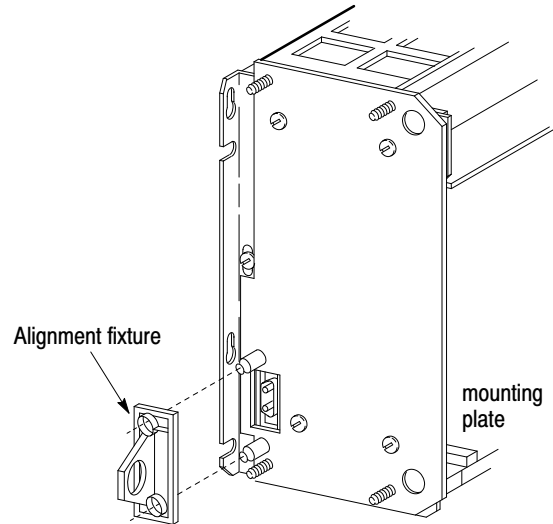

4. Tighten the #10-32 screws to permanently attach the mounting plate to the I/O chassis.

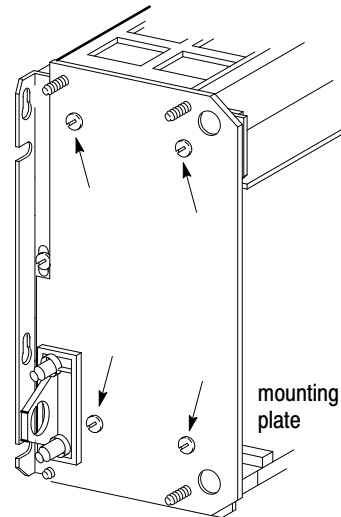

5. Remove the alignment fixture.

Installation Data

120/220V AC Power Supply with User Power
1771-PS7 Series C

6. Align the receiving holes of the power supply over the taper pins on the mounting plate and push until the plug on the power supply is fully inserted into the receptacle on the chassis.

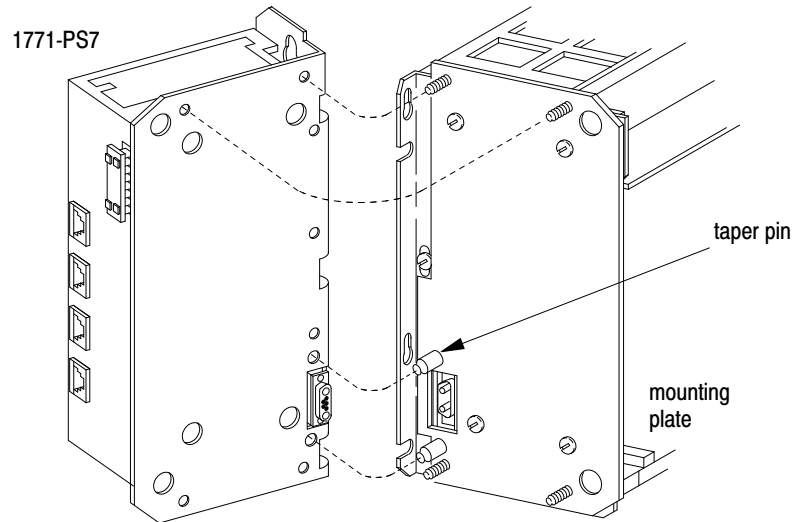

15870

7. Install four #10-32 nuts supplied onto the #10-32 studs now protruding through the power supply mounting holes from the mounting plate.

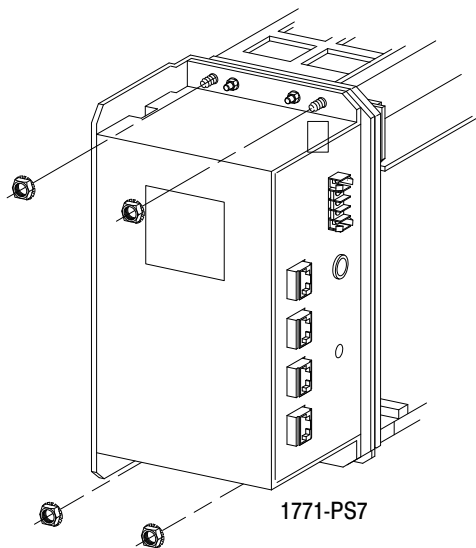

19537

Installation Data

120/220V AC Power Supply with User Power
1771-PS7 Series C

Attaching to Rack-Mounted I/O Chassis

When mounted separately, the 1771-PS7 may be mounted above or next to the I/O chassis. It may **not** be mounted below, since it is necessary to allow convection cooling of both the power supply and the I/O chassis. A minimum vertical distance of six inches should be maintained.

If You Are Mounting the 1771-PS7:	Use this Power Cable (Cat. No.)
within 1 cable-foot of the I/O chassis	1771-CA3B
within 5 cable-feet (1.68M) of the I/O chassis	1771-PSCC

To attach the 1771-PS7 to a rack-mounted I/O chassis (1771-A3B):

1. Mount the 1771-PS7 vertically, above and within the specified cable-feet (for your cable) of the D-sub connector on the top of the I/O chassis.

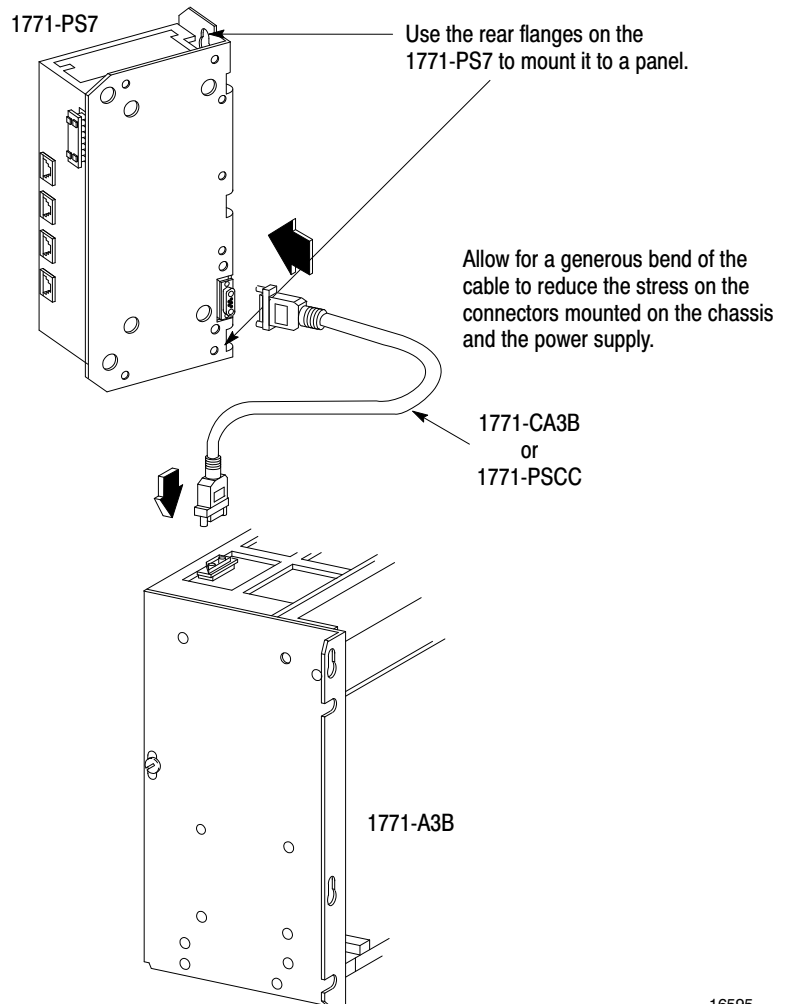

16595

Installation Data

120/220V AC Power Supply with User Power
1771-PS7 Series C

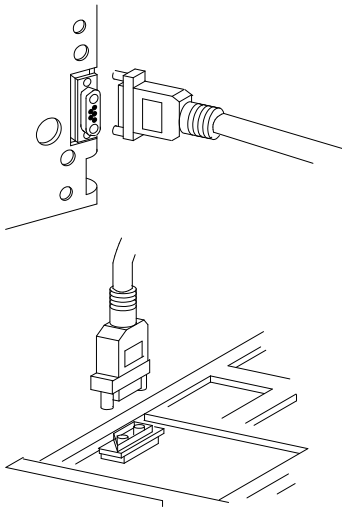

2. Connect one end of the power cable to the D-sub connector located on the side of the 1771-PS7 power supply and tighten the connector screws.
3. Connect the other end of the power cable to the D-sub connector located on the top of the chassis and tighten the connector screws.

Connect User Power to Modules

The 1771-PS7 has 4 connectors for distributing power through 1771-CAS cables to modules within an I/O chassis. The 1771-PS7 can distribute power to:

- IMC controller modules:
 - 3 IMC 120, 120AR motion-controller modules and 1 resolver-excitation module
 - 3 IMC 121 motion-controller modules and 1 resolver-excitation module
 - 3 IMC 123 motion-controller modules and 1 resolver-excitation module
- non-IMC products

Each connector is a 12-pin latch-and-lock shielded type. The pinout of the connector is shown below:

1771-PS7 side

1	+24V dc
2	24V dc Com.
3	+24V dc
4	24V dc Com.
5	+15V dc
6	Com.
7	-15V dc
8	Com.
9	+5V dc
10	Com.
11	+5V dc
12	Com.

Shield
Can

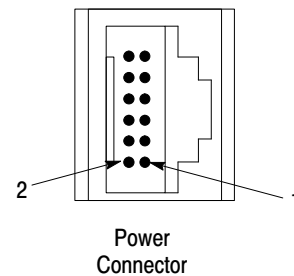

Installation Data

120/220V AC Power Supply with User Power
1771-PS7 Series C

Connecting User Power to IMC Controller Modules

To connect the 1771-PS7 to an IMC 120, 120AR, 121 or 123 motion-controller module and a resolver-excitation module:

1. Make sure the power switch is set to OFF.
2. Connect one end of a 1771-CAS cable:
 - a. to a user power connector on the 1771-PS7
 - b. to the axis on the controller module

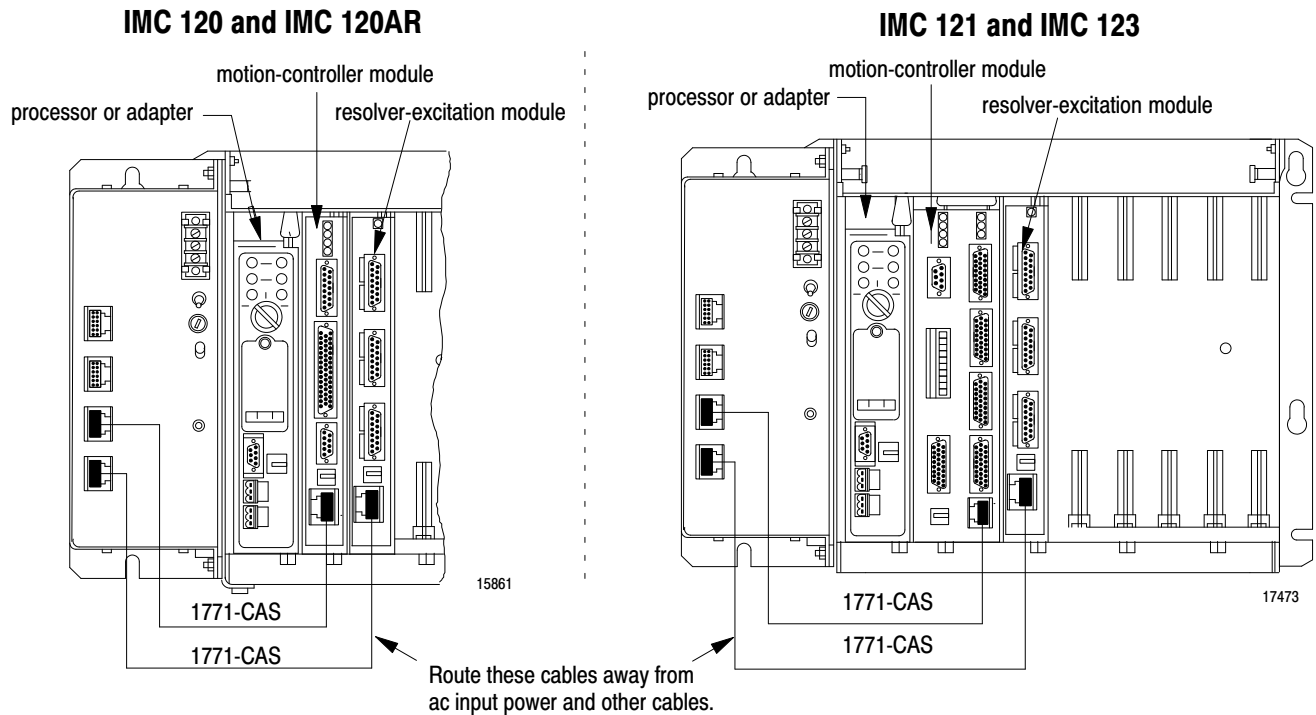

Repeat for the resolver-excitation module and each additional controller module.

For More Information On:	See this Documentation Set(s)	Cat. No.
IMC 120 motion control system IMC 120AR motion control system	IMC 120 Motion Control IMC 120AR Motion Control	1771-HCDOC 1771-HSARS
IMC 121 motion control system	IMC 121 Motion Control	1771-H1DOC
IMC 123 motion control system	IMC 123 Motion Control	1771-H3DOC

Connecting Power to Non-IMC Products

The following figure shows physical dimensions and wiring details for the 1771-CAS cable.

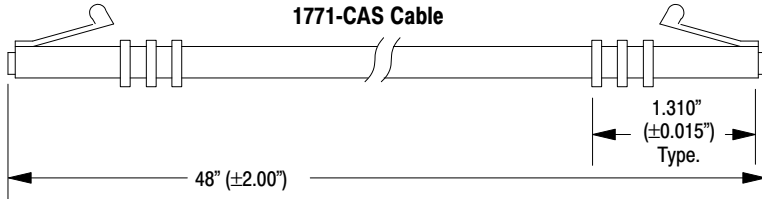

- Material-housing: Polycarbonate 940: UL94V-0; color: G.E. 70455 silver gray.
 Insulator: Polyphenylene oxide-based resin in accordance with MIL-P-46129 (MR). UL94V-1.
 Contacts: 1/4 hard copper nickel alloy with welded gold dot 1000 μ thick in contact area; heat treated beryllium copper spring.
 Shield: 1/2 hard 260 brass. 100-300 μ 9317 Tin-lead.
- 12 conductor, 24AWG (7/32) tinned copper, color as shown.
- Aluminized mylar shield, aluminized side in.
- 26AWG (7/34) tinned copper drain.
- 0.035" thick PVC outer jacket. Low gloss finish. Color to match G.E. 70455 silver gray, O.D. 0.259" \pm 0.009".

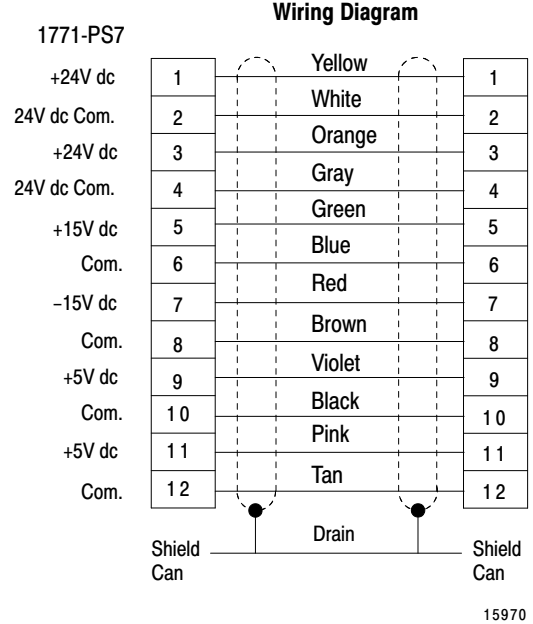

To connect the 1771-PS7 to non-IMC products, you must modify a 1771-CAS cable. Cut the cable as short as possible to minimize voltage losses. Double-up on +24V dc, +5V dc, +24V dc common, +5V dc common and 15V dc commons on each connector, as shown:

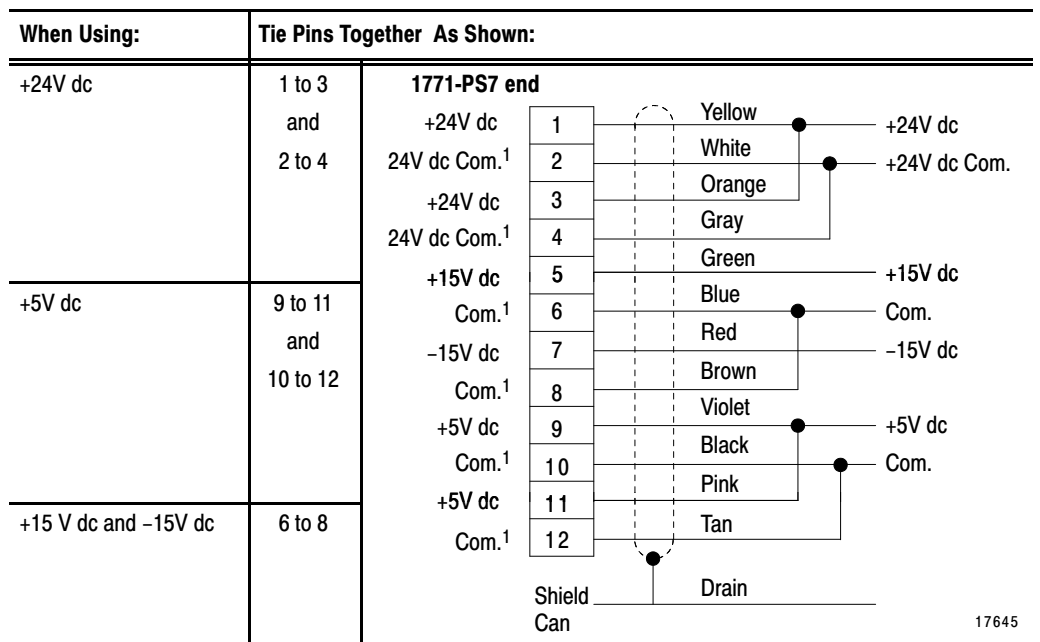

¹ See Figure 1 on page 10.

Installation Data

120/220V AC Power Supply with User Power
1771-PS7 Series C

Figure 1
Signals Designated as COM

Signals designated as Com. (for +5V dc, +15V dc and -15V dc) are tied together in the 1771-PS7 and are isolated from the signal designated as 24V dc Com. so that the 24V supply can be used as a negative supply if required. All the commons are isolated from chassis ground and the backplane (+5V) ground.

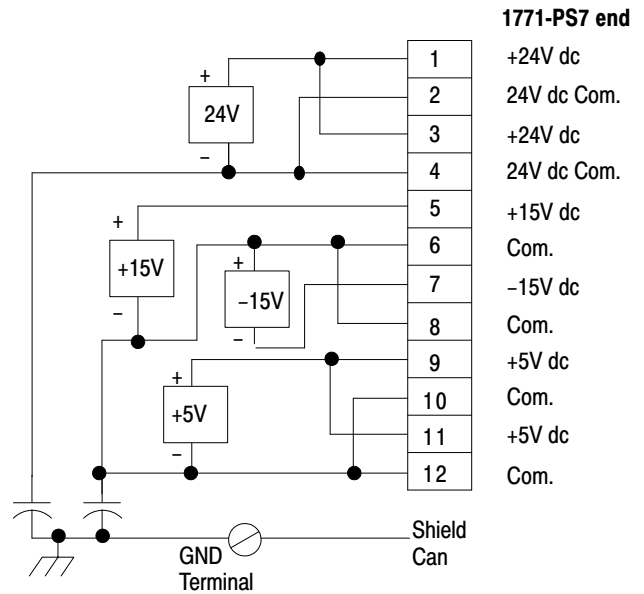

Connect ac Power Source to the 1771-PS7

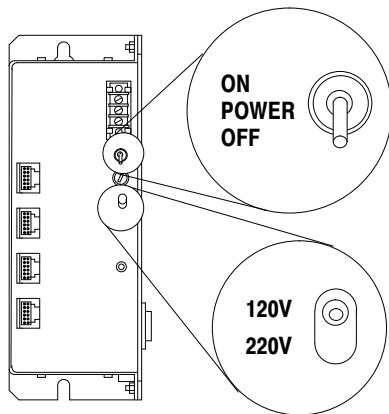

The 1771-PS7 requires input from a 120V ac or 220V ac source. As a safety precaution, the 1771-PS7 is shipped with the input voltage selector switch set to 220V.

To connect power to the 1771-PS7:

1. Make sure the power switch is set to OFF.
2. Use a 1/8" slotted screwdriver to set the input voltage selector switch for 120V ac or 220V ac as required for the input voltage available at installation.



ATTENTION: To avoid damaging the power supply, do not place the screwdriver blade more than 1/4" into the switch slot.

Installation Data

120/220V AC Power Supply with User Power
1771-PS7 Series C

3. Connect the ac power line to the terminal strip on the 1771-PS7.



ATTENTION: You must connect a 14 AWG wire from the GND terminal to the ground bus to provide an adequate safety ground.

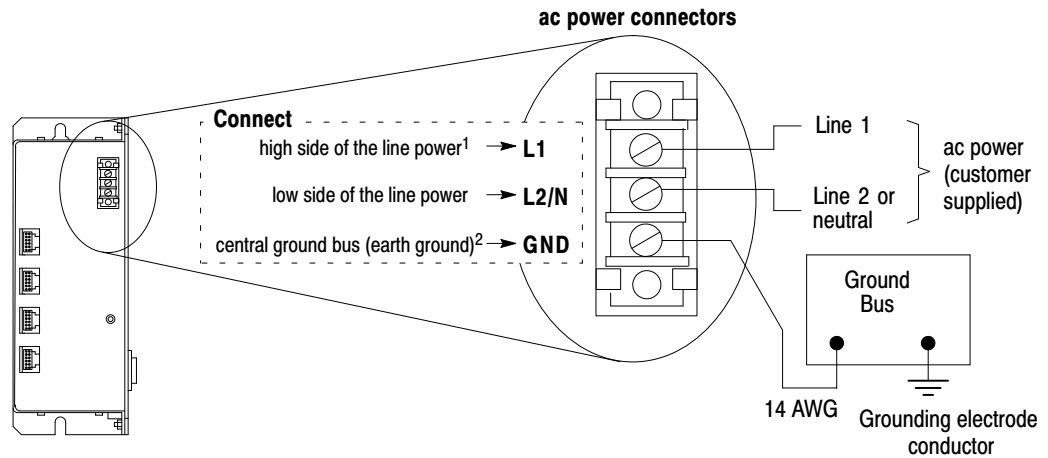

¹ A 3A 250V normal-blow fuse protects the input line L1 from drawing more than 3 amperes.

17569

Troubleshooting

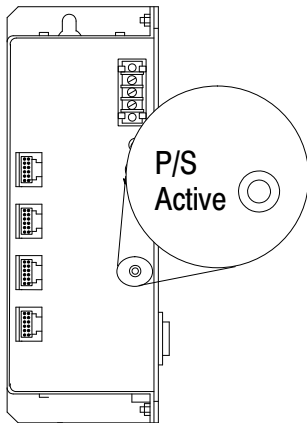

A green P/S ACTIVE LED provides status indication during power supply operation. If the LED does not illuminate during operation, it may be due to:

- backplane overcurrent
- user power overcurrent
- total output power (backplane + user) > 100W
- total user power > 65W
- total +5V user power > 40W
- input voltage level not within specified range
- power supply is inoperative
- blown fuse

For additional assistance, contact your local Allen-Bradley representative.

Installation Data

120/220V AC Power Supply with User Power
1771-PS7 Series C

Specifications

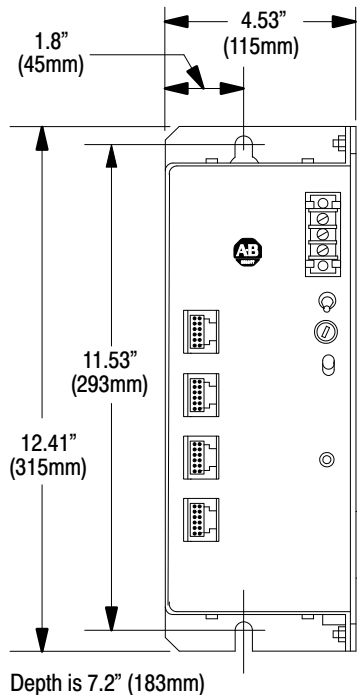

Nominal Input Voltage/Current	120V ac @ 2.0A 220V ac @ 1.0A
Input Voltage Range	97-132V ac (120V ac) 195-264V ac (240V ac)
Frequency Range	47-63Hz
Isolation	Input line to all outputs is 1.5kV rms Input line to chassis is 1.5kV rms User power to backplane power is 1.5kV rms User power to chassis is 707V rms User 24V to User 5/15/-15V is 30V
Output Voltages/Currents	Backplane: +5V dc @ 16 A User Side: see table below
Output Power	100W System Total (max) 65W User Side (max) 80W Backplane (max)
Fuse	3A, 250V 3AG normal blow (Bussmann AGC 3 — Littelfuse 312003)
Weight	6.5 lbs. (with mounting bracket)
Operating Temperature	32 to 140° F (0 to 60° C)
Storage Temperature	-40 to 185° F (-40 to 85° C)
Relative Humidity	5 to 95%, non-condensing
Cables	1771-PSCC 5.5 ft (1.68m) — connects 1771-PS7 to I/O chassis 1771-CA3B 1 ft (.33m) — connects 1771-PS7 to I/O chassis 1771-CAS 4 ft (1.2m) — connects 1771-PS7 to modules

Output	Setpoint ¹	Regulation Limits	Recommended Operating Current Levels	Current Limit Maximum ²	Ripple ³ Peak-Peak
+5V dc	5.20	5.0V to 5.30V	0-8A	8A	100mV @ 5A
+15V dc	15.00	14.43V to 15.57V	0-2.0A	4.3A	100mV @ 1A
-15V dc	-15.01	-14.10V to -15.90V	0-2.0A	4.3A	100mV @ 1A
24V dc	24.01	21.12V to 26.88V	0-2.5A	2.7A	400mV @ 2A

¹ Setpoints for -15V and 24V user outputs will depend upon output loading.

² Current limits are shown for reference only and are maximum currents for the respective outputs based upon a maximum user-side power capability of 65W or a maximum +5V dc user-side capability of 40W.

³ ac component measured at power supply output connector from 5 Hz to 20 MHz.



As a subsidiary of Rockwell International, one of the world's largest technology companies — Allen-Bradley meets today's challenges of industrial automation with over 85 years of practical plant-floor experience. More than 11,000 employees throughout the world design, manufacture and apply a wide range of control and automation products and supporting services to help our customers continuously improve quality, productivity and time to market. These products and services not only control individual machines but integrate the manufacturing process, while providing access to vital plant floor data that can be used to support decision-making throughout the enterprise.

With offices in major cities worldwide

WORLD HEADQUARTERS
Allen-Bradley
1201 South Second Street
Milwaukee, WI 53204 USA
Tel: (1) 414 382-2000
Telex: 43 11 016
FAX: (1) 414 382-4444

EUROPE/MIDDLE EAST/AFRICA HEADQUARTERS
Allen-Bradley Europe B.V.
Amsterdamseweg 15
1422 AC Uithoorn
The Netherlands
Tel: (31) 2975/43500
Telex: (844) 18042
FAX: (31) 2975/60222

ASIA/PACIFIC HEADQUARTERS
Allen-Bradley (Hong Kong) Limited
Room 1006, Block B, Sea View Estate
28 Watson Road
Hong Kong
Tel: (852) 887-4788
Telex: (780) 64347
FAX: (852) 510-9436

CANADA HEADQUARTERS
Allen-Bradley Canada Limited
135 Dundas Street
Cambridge, Ontario N1R 5X1
Canada
Tel: (1) 519 623-1810
FAX: (1) 519 623-8930

LATIN AMERICA HEADQUARTERS
Allen-Bradley
1201 South Second Street
Milwaukee, WI 53204 USA
Tel: (1) 414 382-2000
Telex: 43 11 016
FAX: (1) 414 382-2400