

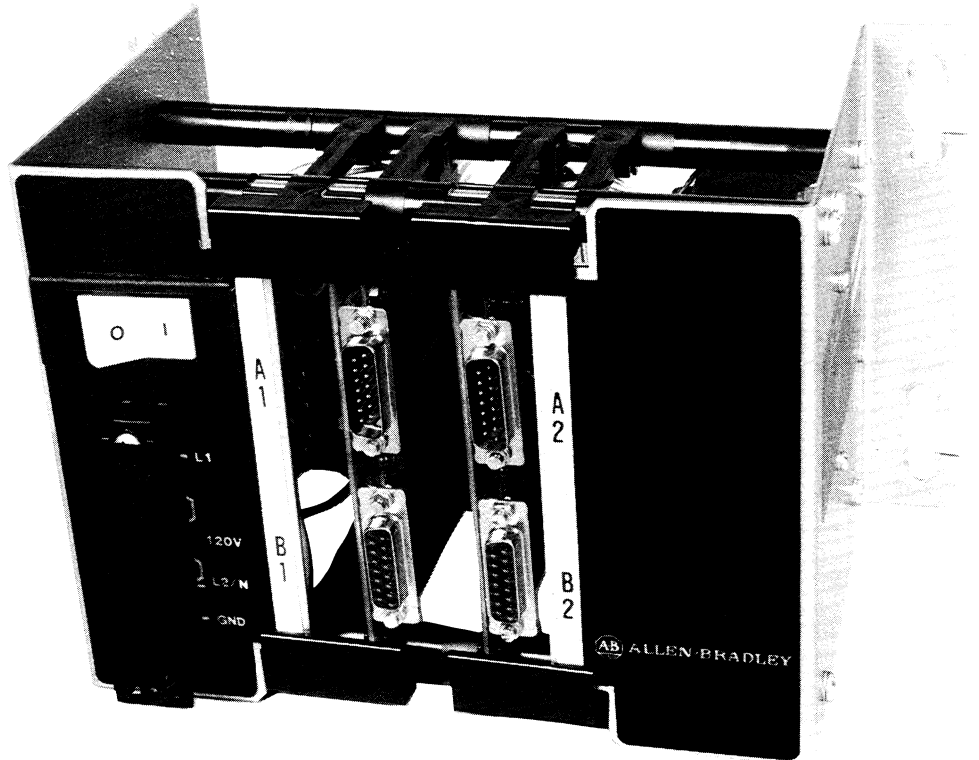

## Allen-Bradley Line Driver/Receiver (Cat. No. 1770-LDA)

---



### Description

The Line Driver/Receiver package supports remote PLC-2 family processor programming. With this package you can extend the cable distance between a PLC-2 family processor and an Industrial Terminal (cat. no. 1770-T1, -T2, -T3) up to 5,000 feet.

You can connect the industrial terminal system to any of the following PLC-2 family processors.

- Mini-PLC-2 Processor (cat. no. 1772-LN1, -LN2, -LN3)
- Mini-PLC-2/15 Processor (cat. no. 1772-LV)
- PLC-2 Processor (cat. no. 1772-LR)
- PLC-2/20 Processor (cat. no. 1772-LP1, -LP2)
- PLC-2/30 Processor (cat. no. 1772-LP3)

Your line driver/receiver consists of:

- a two-slot chassis with two integral 1770-P1 power supplies
- two Line Driver Receiver Modules (cat. no. 1772-DR)
- two Connectors (cat. no. 1770-XE)

**Figure 1**  
**Two slot chassis assembly**

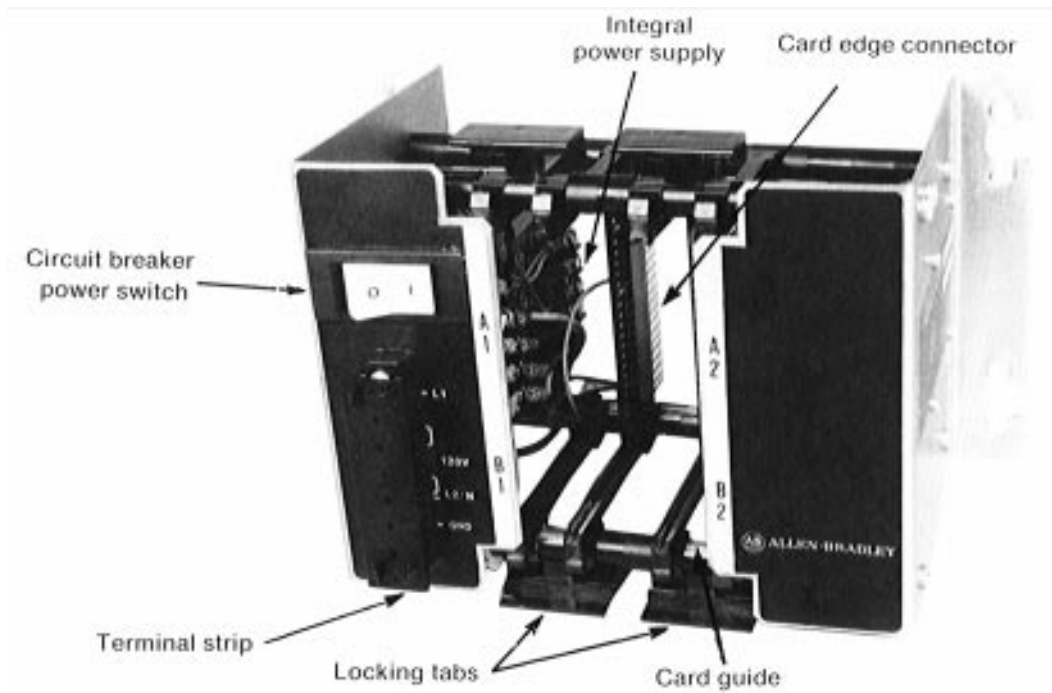

The two-slot chassis assembly (figure 1) consists of:

- card guides, card edge connectors, and locking tabs to support two line driver/receiver modules
- two integral power supplies
- a terminal strip for connection of incoming 120 or 220/240V fused AC power
- a circuit breaker that also acts as a power switch to allow removal and installation of line driver/receiver modules

Figure 2 shows chassis mounting dimensions.

The line driver/receiver modules provide the isolation, signal amplification, and waveform squaring necessary to maintain satisfactory signal levels over a 5000 foot cable length (figure 3).

**Figure 2**  
Line Driver/Receiver chassis mounting dimensions

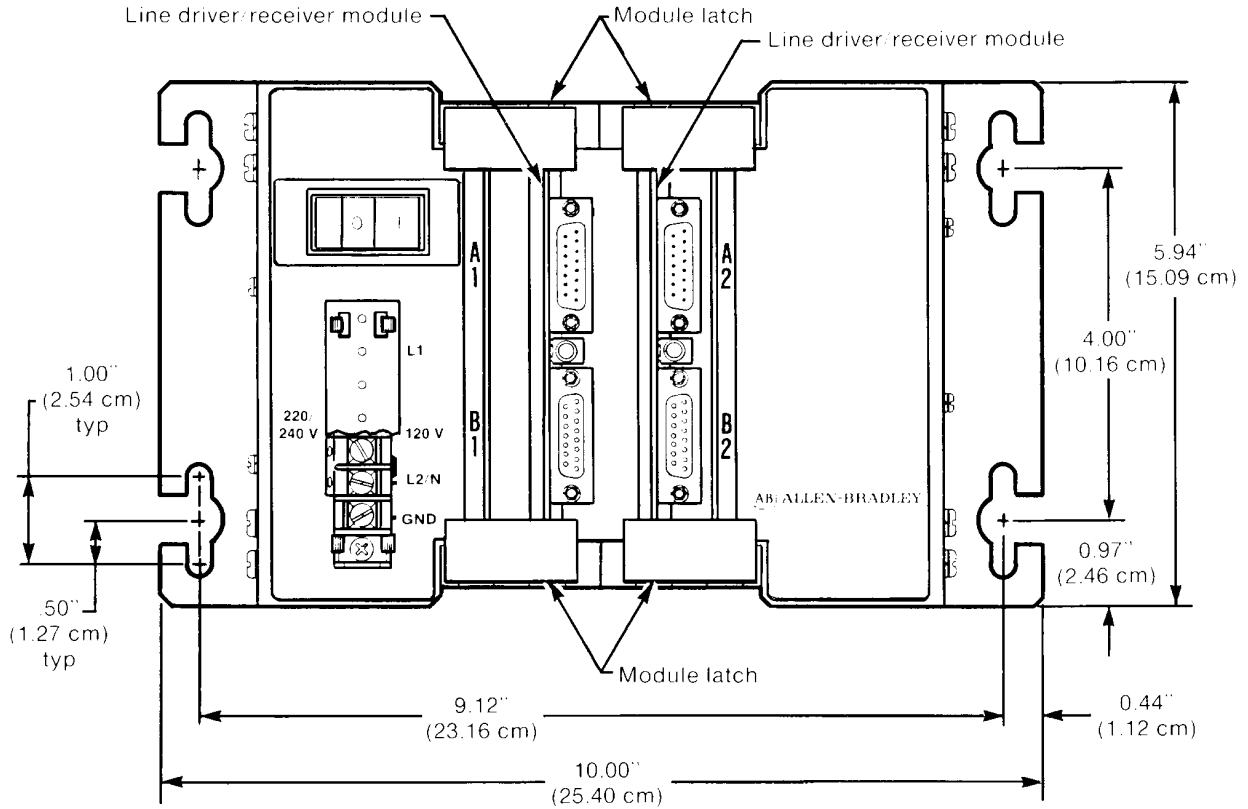

12047

**Figure 3**  
Line Driver/Receiver module

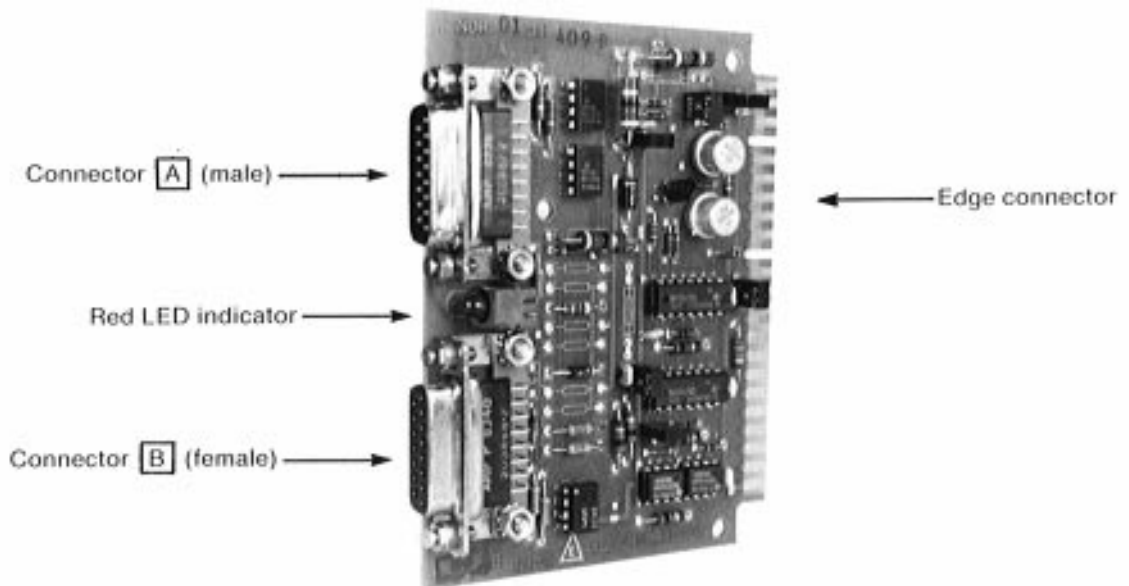

The line driver/receiver module is a plug-in module that mounts in one slot of the two-slot chassis. Card guides on the top and bottom of the rack and locking tabs at the front hold the module securely. The module's edge connector receives DC operating voltage from an integral power supply. Two 15-pin connectors are mounted on the front of each module, one male and one female. Two I/O Interconnect Cables (cat. no. 1778CR) or Belden 8723, connect the A (male) connectors of the four required modules (figure 4). One 1770-CW1 cable connects the PLC-2 family processor with the B (female) connectors on the modules at one end of the link. A 1770-CW2 cable connects the B (female) connectors on the modules at the other end of the link with the industrial terminal.

A red LED indicator is mounted on the module front plate and lights when you connect the first line driver/receiver module to the second line driver/receiver module.

**Figure 4**  
Cabling for dual full duplex configuration

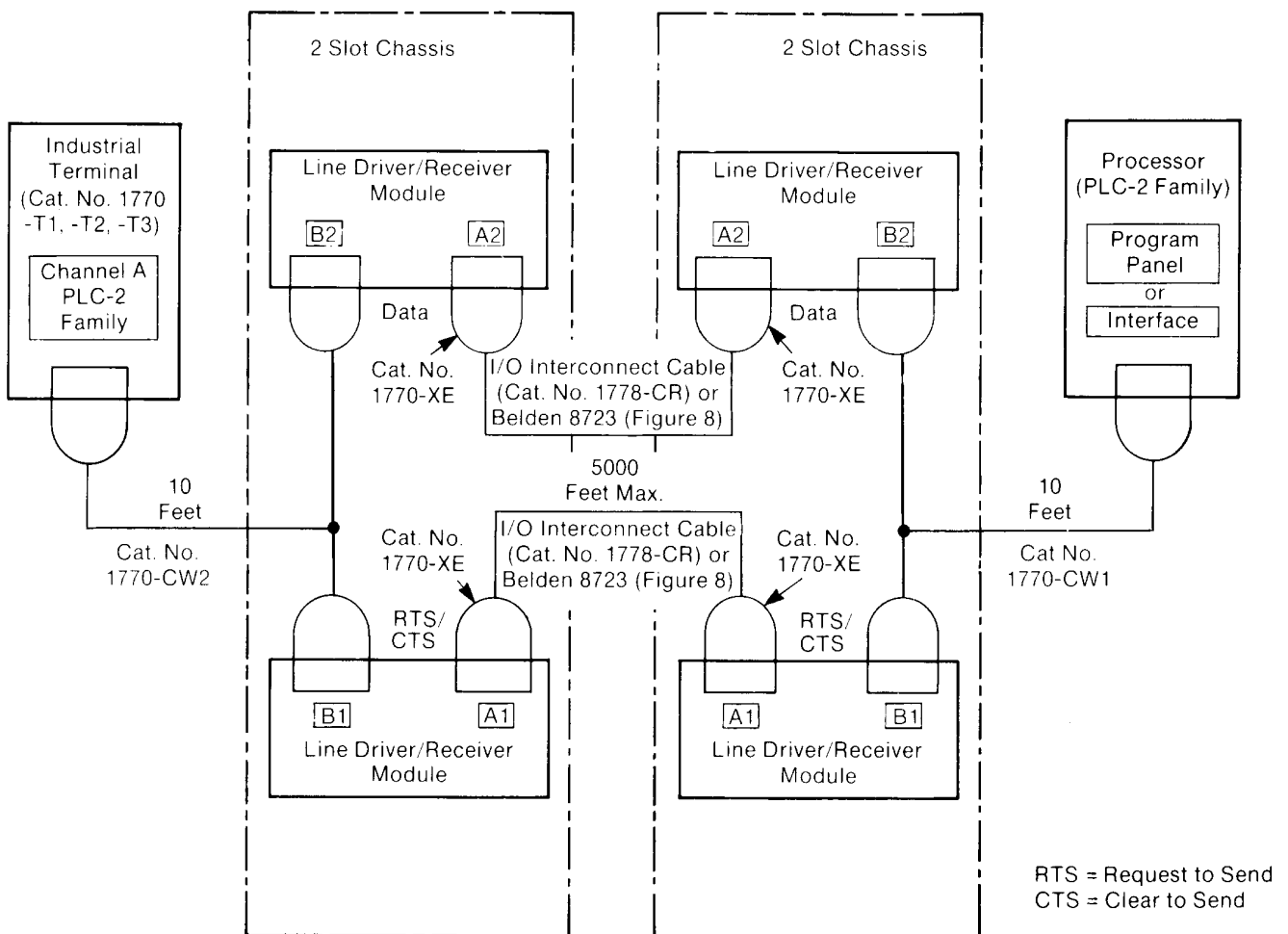

## Dual Full Duplex Configuration

Dual full duplex configuration uses four line driver/receiver modules and two chassis (figure 4). One data link handles communications while the other provides handshaking for communications integrity.

Allen-Bradley recommends dual full duplex configuration to ensure communication integrity between the PLC-2 family processor and the industrial terminal. Communication integrity is essential if forcing functions are entered through the industrial terminal and are not cleared from the terminal before it is turned off. They will remain active until the line driver/receiver power supply is de-energized.

## Material Required

You will need the following items to install a dual full duplex data link (figure 4).

- Two line driver/receivers, **each** consisting of:
  - one two-slot chassis with two integral 1770-P1 power supplies
  - two 1772-DR modules
  - two 15-pin, female, D-shell, solder-cup 1770-XE connectors
- Two I/O interconnect cables (cat. no. 1778-CR) or Belden 8723, 5000 feet maximum length
- Two cables (cat. no. 1770-CW1 and cat. no. 1770-CW2) with three 15-pin, male, D-shell connectors with straight connector hoods (figure 5)

**Figure 5**  
1770-CW1 (left) and 1770-CW2 cables for connecting the chassis with a processor and an industrial terminal



**Figure 6**  
**Mounting detail**

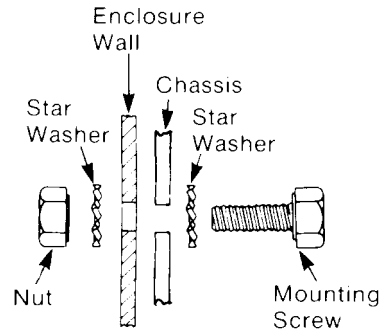

11181

## Chassis and Line Driver/Receiver Module Driver/Receiver Module Installation



**WARNING:** Do not apply power to the power supplies until after the installation is complete and checked. When installation is complete and checked, apply power to the power supplies only in accordance with the power-up procedure given in the section following this installation procedure. Failure to observe this warning might result in injury to personnel and damage to equipment.

Figure 2 shows your chassis mounting dimensions. The chassis must be mounted within 10 feet of your processor and industrial terminal (figure 4). Mount the chassis as follows:

**Step 1** – Mount the chassis in a horizontal position on a surface that is connected to an earth ground. You must have bare metal contact to ensure good electrical contact between the chassis and the mounting surface. Remove paint or other non-conductive finishes from the mounting surface at the point of contact with the chassis mounting bolts (figure 6).

**Step 2** – Place keying bands between pins 3 and 4, 9 and 10 on each line driver/receiver module's slot connector.

**Step 3** – Position the module with the male socket on top and insert the module into the slot.

**Step 4** – Seat each module firmly in its connector by applying even pressure to the edge of the module.

**Step 5** – Lock the module in place with the locking tabs.

## Connections

Complete the following steps before connecting AC line power to the chassis.

**Step 1** – Position jumper for appropriate AC input voltage (120V or 220/240V AC).

**Step 2** – Connect AC input lines to terminals L1 and L2.

**Step 3** – Connect equipment grounding conductor to ground terminal.

**Step 4** – Connect the PLC-2 family processor to the two line drivers B (female) connectors using a 1770-CW1 interconnect cable. Attach cables so that stress is relieved at the connector hoods.

**Figure 7**  
**1770-CW1 cable wiring for connecting the processor to the 1770-LDA**

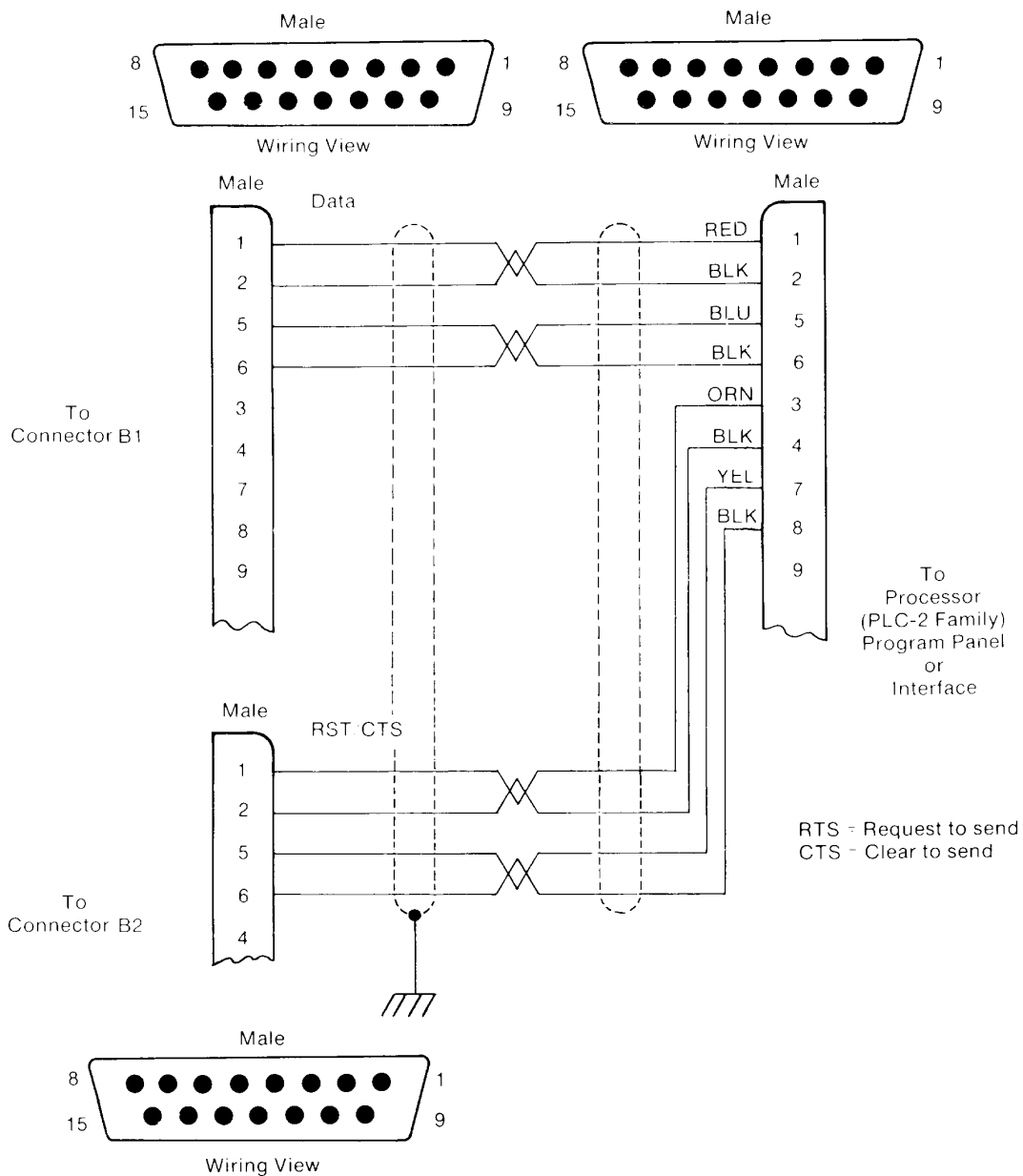

**Step 5** – Connect the industrial terminal Channel A PLC-2 family connector to the two line drivers B (female) connectors using a 1770-CW2 interconnect cable. Attach cables so that stress is relieved at the connector hoods. Refer to figure 8.

**Figure 8**  
**1770-CW2 cable wiring for connecting the industrial terminal to the 1770-LDA**

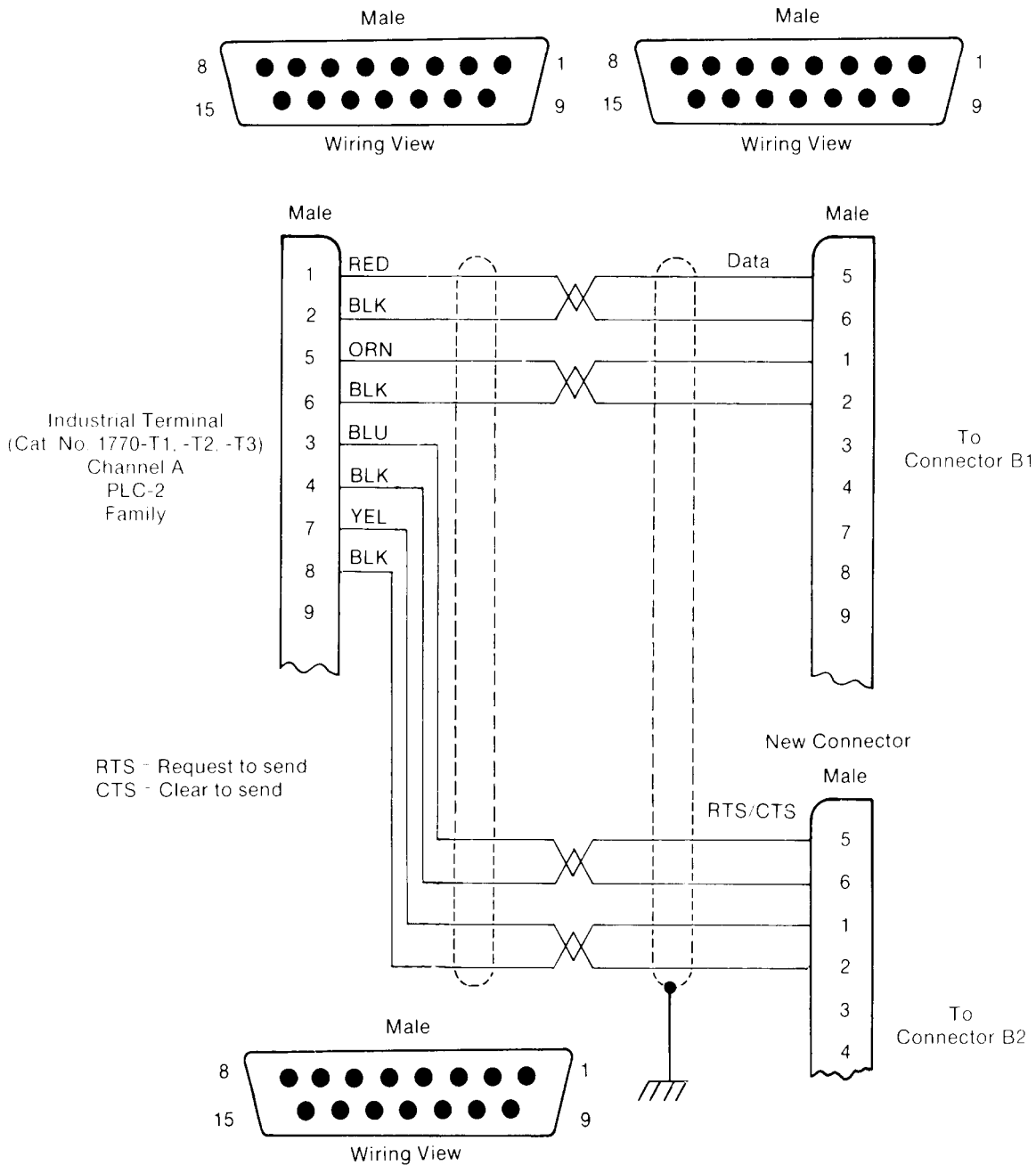



**Step 6** – Connect the line drivers, A (male) connectors using two 1778-CR I/O interconnect cables or Belden 8723 (maximum length 5000 feet) and four, 15-pin 1770-XE connectors. Refer to figures 4 and 9.

**Step 7** – Check all cable wiring against the above steps and figures 4, 7, 8, and 9.

**Figure 9**  
Remote I/O interconnect cable (Cat. No. 1778-CR) and connectors (Cat. No. 1770-XE) for connection of line driver receiver modules

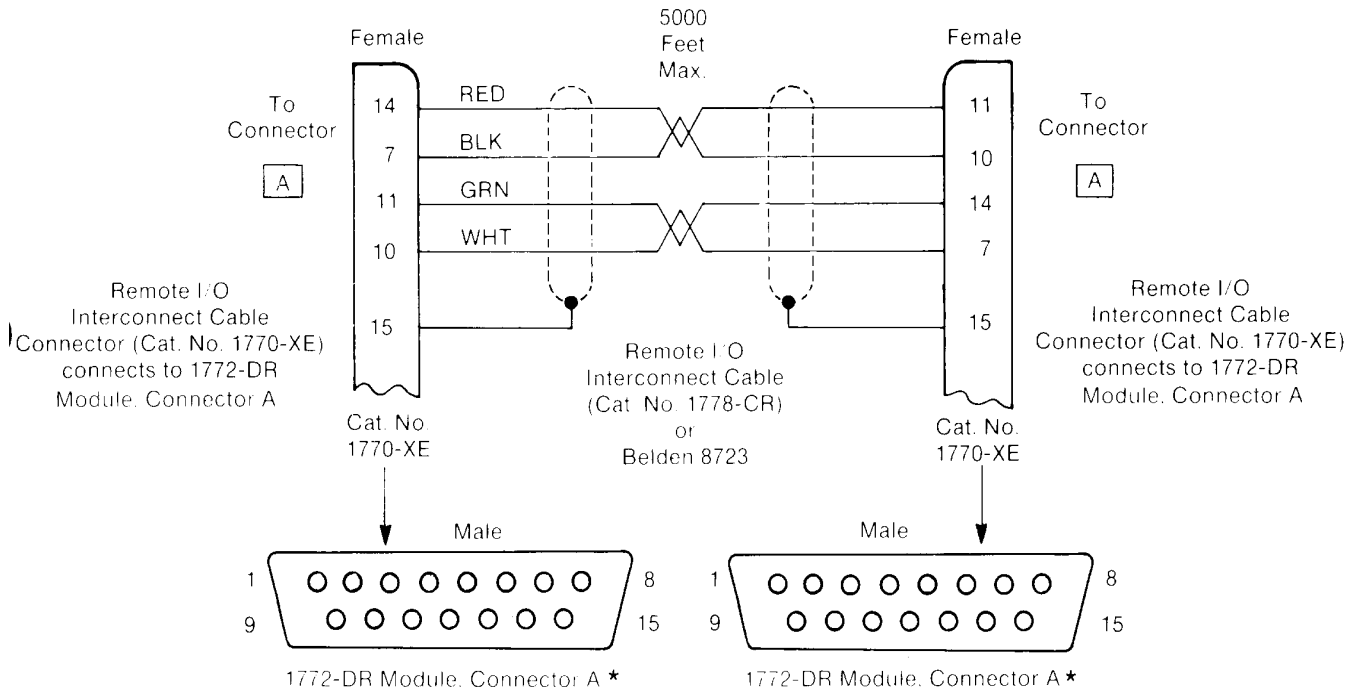

\* Connector A1 goes to Connector A1  
Connector A2 goes to Connector A2  
(refer to Figure 4 if necessary)

## Power-Up

After you complete and check the two data link installations, apply power to the system by performing the following steps. This sequence is necessary to properly establish communication between the processor and industrial terminal.

**Step 1** – Energize the two line driver/receiver power supplies associated with the PLC-2 family processor.

**Step 2** – Energize the two line driver/receiver power supplies associated with the industrial terminal.

**Step 3** – Energize the industrial terminal.

Power has now been applied and communication between the PLC-2 family processor and the industrial terminal has been established.

## Power Shutdown

Remove power from the system by performing the following steps in the order given:

**Step 1** – De-energize the industrial terminal.

You can perform steps 2 and 3 simultaneously.

**Step 2** – De-energize the two line driver/receiver power supplies associated with the industrial terminal.

**Step 3** – De-energize the two line driver/receiver power supplies associated with the PLC-2 family processor.

## Troubleshooting

Figures 4, 7, 8 and 9 provide hardware information required to troubleshoot the data link. Replaceable parts are listed under “Materials Required.”

Analyze any installation and down-time troubles using the following check list:

1. Check that wiring agrees with figures 7, 8, and 9.
2. Check that 1770-CW1 and 1770-CW2 cables are connected to the correct modules at both ends of the link.
3. Check that all line driver/receiver modules are firmly seated in their receptacles.
4. Check that all cable connectors are firmly seated.
5. Check that power supplies are receiving primary input power.

6. Check that power supply DC voltages are present on module receptacle pins.
7. Check that line driver/receiver front panel LED indicator is on. Indicator goes out if the remote I/O interconnect cable opens or if the far end line driver/receiver loses its operating voltages.
8. Check for an open remote I/O interconnect cable or shorted cable. This is not indicated on the industrial terminal screen when using a 1772-LN1, -LN2, -LN3, -LP1, -LP2 PC processor with a 1770-T1, -T2 industrial terminal.
9. Check for an open remote I/O interconnect cable or shorted cable. it will cause the following message to be displayed on the screen:  
Processor Communications Link Noisy Alphanumeric Enabled Only,  
when using a 1772-LN1, -LN2, -LN3, -LP1, or -LP2 processor or a 1772-LV or 1772-LP3 processor and the 1770-T3 industrial terminal.

## Specifications

### Chassis

#### Input Voltage

- 105 to 125V rms
- 205 to 250V rms

#### Input Frequency

- 50 to 440 Hz

#### Input Power

- 30W (max.)

#### Circuit Breaker

- 0.5A

#### Output Voltage

(per 1770-P1 power supply)

- $\pm 15V$  DC
- + 5V DC

#### Output Current

(per 1770-P1 power supply)

- 150mA ( $\pm 15V$  DC)
- 300mA (+ 5V DC)

### Module Capacity

- Two Line Driver/Receiver Modules

Max Distance from PLC-2 Family Processor or Industrial Terminal

- 10 cable feet

Max Distance between 1770-LDA Chassis

- 5000 cable feet

### Module

#### Voltage Requirements

- 150mA ( 15V DC)
- 300mA ( 5V DC)

#### Isolation

- 1500V peak  
(optoelectronic coupled)

### Environmental Conditions

- Operational Temperature:

0 to 60°C (32 to 140°F)

- Storage Temperature:

-40 to 85° C (-40 to 185° F)

- Relative Humidity:

5 to 95% (without condensation)

#### Weight

(Chassis and two Line Driver/Receiver Modules)

3kg (6 lbs 10 ozs)

#### Keying

- Between 3 and 4
- Between 9 and 10



As a subsidiary of Rockwell International, one of the world's largest technology companies — Allen-Bradley meets today's challenges of industrial automation with over 85 years of practical plant-floor experience. More than 11,000 employees throughout the world design, manufacture and apply a wide range of control and automation products and supporting services to help our customers continuously improve quality, productivity and time to market. These products and services not only control individual machines but integrate the manufacturing process, while providing access to vital plant floor data that can be used to support decision-making throughout the enterprise.

### With offices in major cities worldwide

**WORLD HEADQUARTERS**  
Allen-Bradley  
1201 South Second Street  
Milwaukee, WI 53204 USA  
Tel: (1) 414 382-2000  
Telex: 43 11 016  
FAX: (1) 414 382-4444

**EUROPE/MIDDLE EAST/AFRICA HEADQUARTERS**  
Allen-Bradley Europe B.V.  
Amsterdamseweg 15  
1422 AC Uithoorn  
The Netherlands  
Tel: (31) 2975/43500  
Telex: (844) 18042  
FAX: (31) 2975/60222

**ASIA/PACIFIC HEADQUARTERS**  
Allen-Bradley (Hong Kong) Limited  
Room 1006, Block B, Sea View Estate  
28 Watson Road  
Hong Kong  
Tel: (852) 887-4788  
Telex: (780) 64347  
FAX: (852) 510-9436

**CANADA HEADQUARTERS**  
Allen-Bradley Canada Limited  
135 Dundas Street  
Cambridge, Ontario N1R 5X1  
Canada  
Tel: (1) 519 623-1810  
FAX: (1) 519 623-8930

**LATIN AMERICA HEADQUARTERS**  
Allen-Bradley  
1201 South Second Street  
Milwaukee, WI 53204 USA  
Tel: (1) 414 382-2000  
Telex: 43 11 016  
FAX: (1) 414 382-2400