



ControlLogix System

Bulletin 1756



Allen-Bradley

by ROCKWELL AUTOMATION

Selection Guide

What's Inside

Topic	Page
ControlLogix and GuardLogix Systems	3
High Availability Systems	6
Safety Systems	8
ControlLogix 5580 and ControlLogix 5570 Controllers	9
ControlLogix-XT 5580 and ControlLogix-XT 5570 Controllers	10
ControlLogix 5580 Process Controllers	10
ControlLogix 5580 No Stored Energy (NSE) Controllers	10
GuardLogix 5580 and GuardLogix 5570 Controllers	11
Armor ControlLogix and Armor GuardLogix On-Machine Controllers	12
Controller Accessories	13
ControlLogix I/O Modules	14
ControlLogix Compute Modules	20
ControlLogix Communication Modules	21
ControlLogix Integrated Motion	23
ControlLogix Chassis	24
ControlLogix Power Supplies	25

What's New

The new products include the following.

Topic	Page
Added ControlLogix-XT™ catalog numbers	Throughout
Added Logix SIS Redundancy information	6, 7, 8
Added information about Safety Systems	8

Rockwell Automation recognizes that some of the terms that are currently used in our industry and in this publication are not in alignment with the movement toward inclusive language in technology. We are proactively collaborating with industry peers to find alternatives to such terms and making changes to our products and content. Please excuse the use of such terms in our content while we implement these changes.

ControlLogix and GuardLogix Systems

ControlLogix® and GuardLogix® systems provide discrete, drives, motion, process, and safety control together with communication and state-of-the-art I/O in a small, cost-competitive package. The system is modular, so you can design, build, and modify it efficiently with significant savings in training and engineering.

To begin designing your system, identify the Logix controller appropriate for your application.

Logix Controllers Comparison

Characteristic	ControlLogix 5580 Controllers GuardLogix 5580 Controllers	ControlLogix 5570 Controllers GuardLogix 5570 Controllers	Armor™ ControlLogix® 5570 Controllers Armor™ GuardLogix® 5570 Controllers
Application Options	Standard Safety Extended temperature Conformal coating		IP67 Ingress Protection Standard Safety
User memory	Standard: 3 MB...40 MB Safety: 1.5 MB...6 MB	Standard: 2 MB...32 MB Safety: 1 MB...4 MB	
Built-in ports	1-port EtherNet/IP™ 10 Mbps/100 Mbps/1 Gbps 1-port USB client	1-port USB Client	Dual-port EtherNet/IP 1-port USB client
Controller connections	Not applicable		500 connections
Network nodes	100...300		Not applicable

For detailed specifications, see the ControlLogix and GuardLogix Controllers Technical Data, publication [1756-TD001](#).

IMPORTANT

When a ControlLogix or GuardLogix product that is rated for harsh environments (corrosive atmosphere, extended temperature, etc.) is used in a system with other ControlLogix products that have lower specification values, the system is derated to the lowest common value.

EXAMPLE: If the maximum operating temperature specification found in the Technical Data for your ControlLogix-XT module is 70 °C (158 °F) and you pair it with a ControlLogix chassis that is temperature rated to 60 °C (140 °F), your system is derated to 60 °C (140 °F).

To ensure that your system is equipped for harsh environments, compare the corrosive atmosphere, temperature, and other specifications found in the Technical Data publication for each product.

Example Configuration - ControlLogix System

A ControlLogix system consists of the following:

- A ControlLogix or GuardLogix controller
- Studio 5000® environment
- ControlLogix I/O modules
- Network communication modules
- A 1756 chassis in which the system resides

A more comprehensive system could also include:

- Multiple controllers in one chassis
- Multiple controllers joined across networks
- I/O in multiple platforms that are distributed in many locations and connected over multiple networks
- Components with a 'K', or an 'XT' in the catalog number have extended protection in harsh, corrosive environments
- Select ControlLogix-XT or GuardLogix-XT™ components that feature extended temperature limits

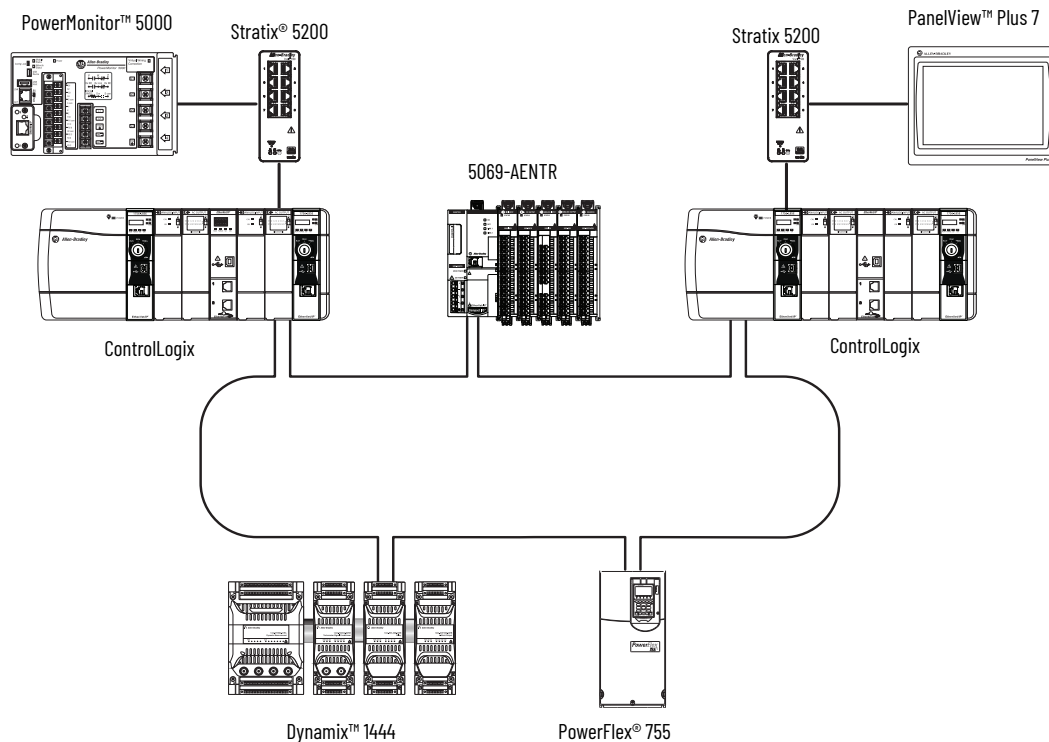

Example Configuration - GuardLogix System

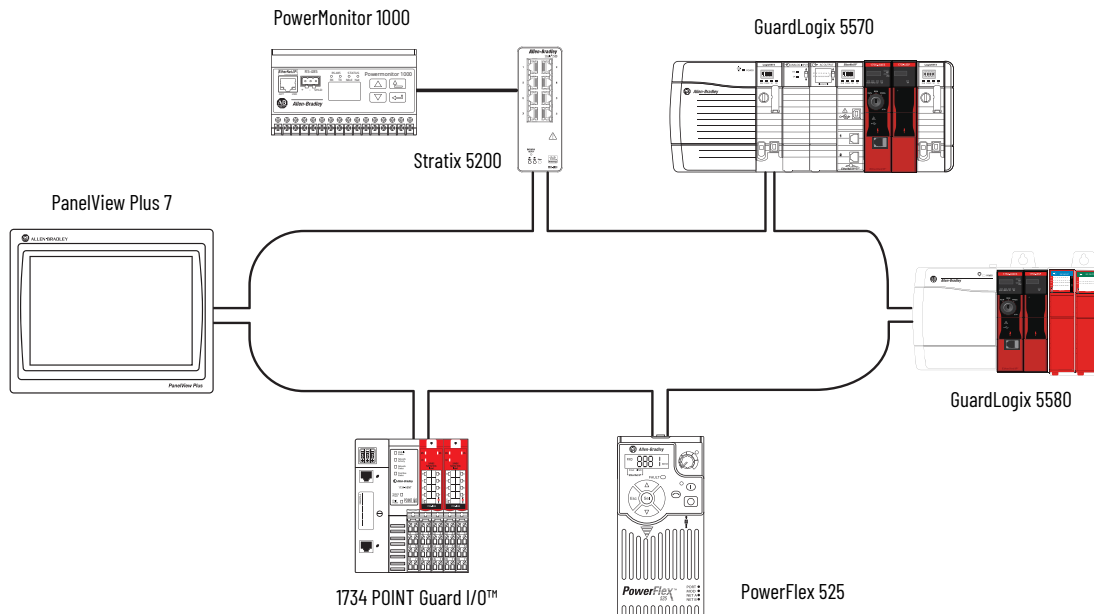

Example Configuration - Armor ControlLogix and Armor GuardLogix Systems

On-Machine™ standard and safety controllers support the same temperature range of ControlLogix, while offering global certifications and ratings, and Ingress Protection (IP67) for dust and wash-down protection for immersion between 15 cm...1 m (5.91...393.70 in.) in harsh environments.

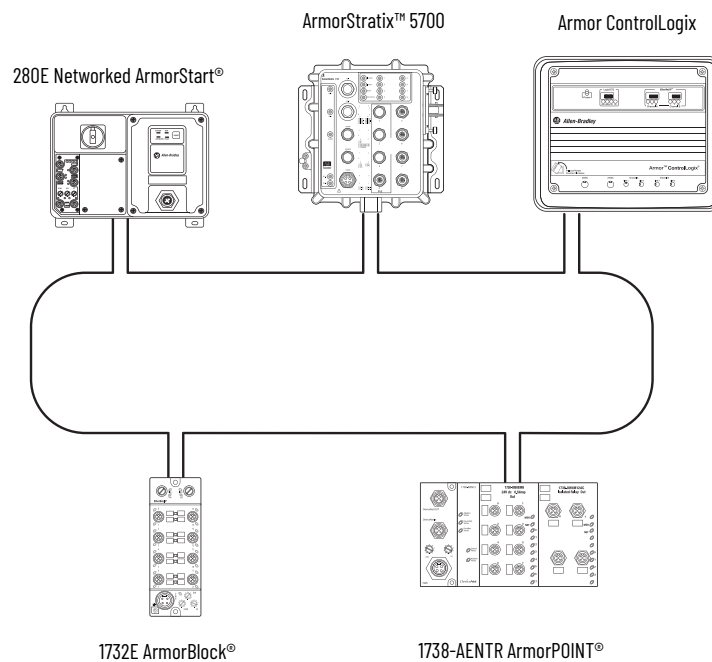

High Availability Systems

Availability is the percentage of time that a system is functioning and able to perform its mission. High availability is a characteristic of a system that aims to achieve an agreed level of availability for a higher-than-normal period. Logix SIS and ControlLogix systems support high availability when hardware and configuration requirements are met.

For more information about ControlLogix 5580 high availability solutions for control, I/O, and other aspects of a system, refer to the High Availability System Reference Manual, publication [HIGHAV-RM002](#).

Example Configuration - ControlLogix Redundancy System

ControlLogix redundancy is designed for non-safety applications that require high availability. In ControlLogix redundancy, redundant controllers are configured to transition from a primary to a secondary controller if there is a fault. The redundant controllers can communicate with only standard I/O modules.

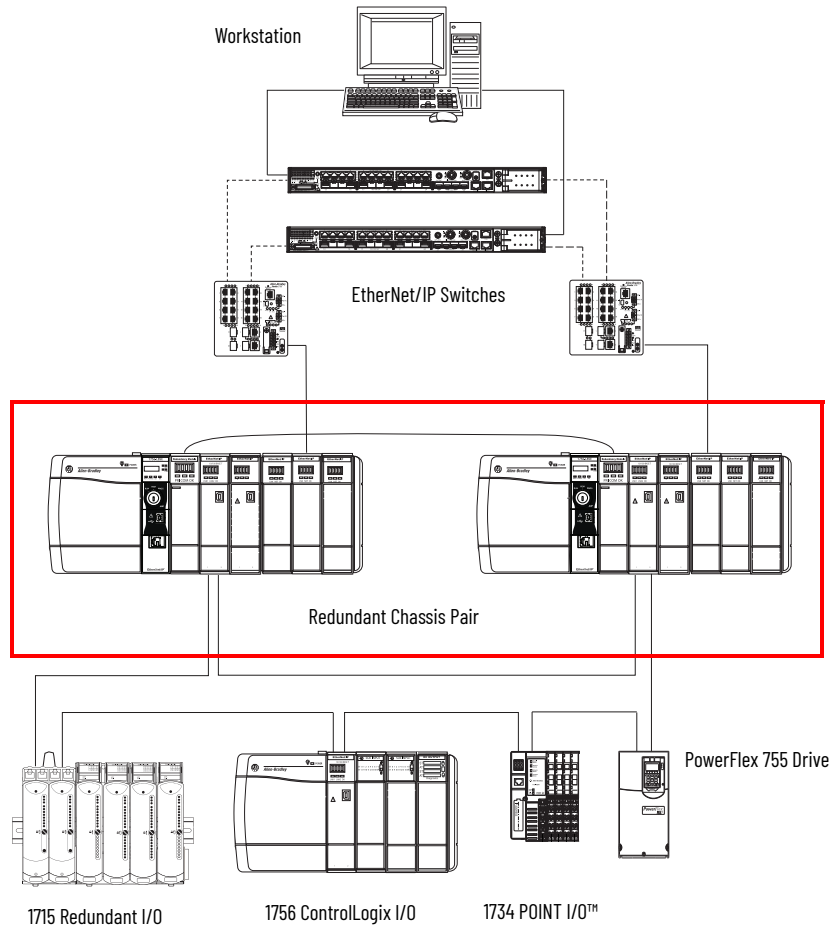

For more information about high availability systems that use ControlLogix 5580 or ControlLogix 5570 redundancy, refer to the Redundancy Systems User Manual, publication [1756-UM015](#).

Example Configuration - Logix SIS Redundancy System

Logix SIS redundancy is designed for safety applications that require high availability. In a Logix SIS system, redundant safety controllers simultaneously execute the safety task to maintain operation but only one controller executes standard tasks.

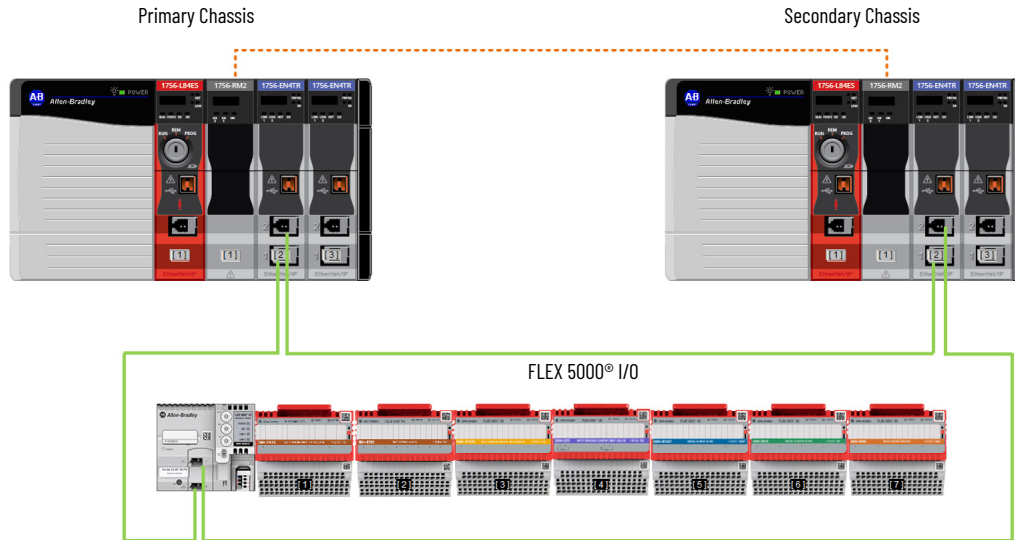

For more information about high availability systems that use Logix SIS redundancy, refer to the Redundancy Systems User Manual, publication [1756-UM015](#).

Safety Systems

As the attributes that define machine safety and process safety solutions become more common, there are multiple ControlLogix and GuardLogix controller systems that meet safety requirements.

Controller Redundancy Required? Increases controller availability	SIL 3 Required? Relates to PFD	Redundant I/O Required? Increases I/O availability and Energize to Trip action is more easily enabled	Recommended Solution
Yes	Yes	Yes	AADvance® safety system
		No	Logix SIS with 5094 FLEX 5000 safety I/O
	No	Yes	ControlLogix SIL 2 with 1715 redundant I/O
		No	Logix SIS with 5094 FLEX 5000 safety I/O
No	Yes	Yes	AADvance® safety system
		No	GuardLogix controller with a safety partner and safety I/O
	No	Yes	ControlLogix SIL 2 with 1715 redundant I/O
		No	GuardLogix controller with safety I/O



For detailed redundancy requirements, see the Redundancy Systems User Manual, publication [1756-UM015](#).

For information about how to safely apply AADvance controllers for a Safety Instrumented Function, see the AADvance Safety Manual, publication [1CSTT-RM446](#).

For information on using ControlLogix controllers in SIL 2 applications, see the Using ControlLogix in SIL 2 Applications Safety Reference Manual, publication [1756-RM001](#).

For information about achieving and maintaining SIL 2/PLd and SIL 3/PLe with the GuardLogix 5580 controller system, see the GuardLogix 5580 and Compact GuardLogix 5380 Controller Systems Safety Reference Manual, publication [1756-RM012](#).

For more information about Logix SIS systems, which are type-approved and certified for use in safety applications, see Logix SIS in SIL 2/3 Safety Applications Reference Manual, publication [1756-RM015](#).

ControlLogix 5580 and ControlLogix 5570 Controllers



The ControlLogix controller is part of the Logix 5000® family of controllers.

- ControlLogix controllers can monitor and control I/O across the ControlLogix backplane, and over networks. ControlLogix controllers can communicate over EtherNet/IP, ControlNet®, DeviceNet®, Remote I/O networks, and many third-party process and device networks.
- The controller can be placed into any slot of a ControlLogix chassis and multiple controllers can be installed in the same chassis. Multiple controllers in the same chassis communicate with each other over the backplane (just as controllers can communicate over networks) but operate independently.
- To provide communication for a ControlLogix controller, install the appropriate communication interface module into the chassis.
- ControlLogix 5580 controllers have a built-in EtherNet/IP port, but you can also use communication interface modules in the chassis.

Feature	ControlLogix 5580 Controllers	ControlLogix 5570 Controllers
User Memory	1756-L81E, 1756-L81EK, 1756-L81E-NSE, 1756-L81E-NSEXT, 1756-L81EXT, 1756-L81EP, 1756-L81EPXT: 3 MB 1756-L82E, 1756-L82EK, 1756-L82E-NSE, 1756-L82E-NSEXT, 1756-L82EXT: 5 MB 1756-L83E, 1756-L83EK, 1756-L83E-NSE, 1756-L83E-NSEXT, 1756-L83EXT, 1756-L83EP, 1756-L83EPXT: 10 MB 1756-L84E, 1756-L84EK, 1756-L84E-NSE, 1756-L84E-NSEXT, 1756-L84EXT: 20 MB 1756-L85E, 1756-L85EK, 1756-L85E-NSE, 1756-L85E-NSEXT, 1756-L85EXT, 1756-L85EP, 1756-L85EPXT: 40 MB	1756-L71: 2 MB 1756-L72: 4 MB 1756-L73, 1756-L73XT: 8 MB 1756-L74: 16 MB 1756-L75: 32 MB
Controller tasks	<ul style="list-style-type: none"> 32 tasks 1000 programs/task Event tasks: all event triggers 	<ul style="list-style-type: none"> 32 tasks 1000 programs/task⁽¹⁾ Event tasks: all event triggers
Built-in communication ports	<ul style="list-style-type: none"> 1-port USB client Single-port EtherNet/IP 	1-port USB Client
Communication options	<ul style="list-style-type: none"> EtherNet/IP ControlNet DeviceNet Remote I/O SynchLink™ Third-party process and device networks 	
Controller connections	Not applicable	500 connections
Node capacity	Logix Designer application, version 30 or later: <ul style="list-style-type: none"> All 1756-L81 catalog numbers: 100 EtherNet/IP nodes⁽³⁾ All 1756-L82 catalog numbers: 175 EtherNet/IP nodes⁽³⁾ All 1756-L83 catalog numbers: 250 EtherNet/IP nodes⁽²⁾ All 1756-L84 catalog numbers: 250 EtherNet/IP nodes⁽³⁾ All 1756-L85 catalog numbers: 300 EtherNet/IP nodes⁽³⁾ 	Not applicable
Network connections, per network module ⁽³⁾	Not applicable ⁽⁴⁾	<ul style="list-style-type: none"> 1000 class 1 CIP™ and 528 class 3 CIP; 512 TCP (1756-EN4z) 256 CIP; 128 TCP (1756-EN2/3z) 128 CIP; 64 TCP (1756-ENBT) 128 ControlNet (1756-CN2/B) 100 ControlNet (1756-CN2/A)
Controller redundancy	Full support in Studio 5000 Logix Designer® application version 33 and later. The Ethernet port is disabled on controllers that are enabled for redundancy.	Full support
Integrated motion	<ul style="list-style-type: none"> EtherNet/IP connection With Logix Designer application, version 31 or later: <ul style="list-style-type: none"> SERCOS interface Analog options (encoder input, LDT input, SSI input) Controllers that are enabled for redundancy do not support motion. 	<ul style="list-style-type: none"> EtherNet/IP connection SERCOS interface Analog options (encoder input, LDT input, SSI input) Controllers enabled for redundancy do not support motion.
Programming languages	<ul style="list-style-type: none"> Relay ladder Structured text Function block Sequential function chart (SFC) 	<ul style="list-style-type: none"> Relay ladder Structured text Function block Sequential function chart (SFC)

(1) Studio 5000 Logix Designer, version 23 and earlier, is limited to 100 Programs/Task.

(2) This value is the maximum number of EtherNet/IP nodes that the controller supports. Use the Integrated Architecture® Builder design tool to lay out and validate your system design and additional node options. For further information on nodes on an EtherNet/IP network, see the ControlLogix 5580 and GuardLogix 5580 Controllers User Manual, publication [1756-UM543](#).

(3) For the ControlLogix 5580 controllers, the total number of devices cannot exceed the total number of devices that the controller supports. The number of connections per network module shown is the maximum designed capacity of the modules. The device data size and requested data rate determine the actual device capacity.

(4) This value is determined by the node capacity for the ControlLogix 5580 controllers. See the node capacity feature for more information.

ControlLogix-XT 5580 and ControlLogix-XT 5570 Controllers

The ControlLogix-XT controllers function in the same way and have the same features as standard ControlLogix controllers. They include control and communication system components that have an extra degree of protection when exposed to harsh, corrosive environments. While standard ControlLogix controllers can withstand temperatures from 0...60 °C (33...140 °F), ControlLogix-XT controllers can withstand temperatures from -25...+70 °C (-13...+158 °F).



ControlLogix 5580 Process Controllers

The process controller is an extension of the Logix 5000 controller family that focuses on plant-wide process control. The process controller comes configured with a default process-tasking model and dedicated PlantPAx® process instructions optimized for process applications and that improve design and deployment efforts.

The ControlLogix-XT process controller hardware also have an extra degree of protection when exposed to harsh, corrosive environments, and can be used in temperature extremes from -25...+70 °C (-13...+158 °F) when deployed as part of a Logix-XT system.



ControlLogix 5580 No Stored Energy (NSE) Controllers

The NSE controller is intended for use in applications that require the installed controller to deplete its residual stored energy to specific levels before transporting it into or out of your application. The real-time clock (RTC) does not retain its time and date when the power is off.

The residual stored energy of the NSE controller depletes to 400 µJ or less in 40 seconds.



GuardLogix 5580 and GuardLogix 5570 Controllers



GuardLogix 5580 and GuardLogix 5570 controllers provide safety control. A major benefit of this system is that it is still one project, safety and standard together. The safety partner controller is an automatically configured part of the system and does not require setup. If the safety partner is present, the safety integrity is SIL3. If no safety partner is present, the safety integrity is SIL2. On the standard side of the GuardLogix controller, all functions operate like a regular Logix controller.

GuardLogix Controller	Safety Partner ⁽¹⁾
1756-L81ES, 1756-L82ES, 1756-L83ES, 1756-L84ES, 1756-L85ES	1756-L8SP
1756-L81ESK, 1756-L82ESK, 1756-L83ESK, 1756-L84ESK	1756-L8SPK
1756-L81ESXT, 1756-L82ESXT, 1756-L83ESXT, 1756-L84ESXT	1756-L8SPXT
1756-L81EXTS, 1756-L82EXTS, 1756-L83EXTS, 1756-L84EXTS	1756-L8XTSP
1756-L71S, 1756-L72S, 1756-L73S	1756-L7SP
1756-L73SXT	1756-L7SPXT

(1) In SIL 3 applications, one safety partner is required for each GuardLogix 5580 controller.

With the GuardLogix 5580 controller, you can achieve up to SIL 2/PLd (Category 3) with one controller and the use of the safety task and safety I/O. You must use a primary controller and a safety partner to achieve SIL 3/PLe (Category 4).

The GuardLogix controller system is type-approved and certified for use in safety applications up to and including SIL 3 according to IEC 61508, and applications up to and including PLe/Cat.4 according to ISO 13849-1.

GuardLogix-XT™ 5580 controllers can withstand temperature ranges from -25...+70 °C (-13...+158 °F), and have an extra degree of protection when exposed to harsh, corrosive environments.

Guard I/O™ modules provide field device connectivity on Ethernet or DeviceNet networks. For safety interlocking between GuardLogix controllers, use Ethernet or ControlNet networks. Multiple GuardLogix controllers can share safety data for zone to zone interlocking, or one GuardLogix controller can use distributed safety I/O between different cells/areas.

Feature	GuardLogix 5580 Controllers	GuardLogix 5570 Controllers
User Memory	1756-L81ES, 1756-L81ESK, 1756-L81EXTS, 1756-L81ESXT: 3 MB standard, 1.5 MB safety 1756-L82ES, 1756-L82ESK, 1756-L82EXTS, 1756-L82ESXT: 5 MB standard, 2.5 MB safety 1756-L83ES, 1756-L83ESK, 1756-L83EXTS, 1756-L83ESXT: 10 MB standard, 5 MB safety 1756-L84ES, 1756-L84ESK, 1756-L84EXTS, 1756-L84ESXT: 20 MB standard, 6 MB safety 1756-L85ES: 40 MB standard, 3 MB safety	1756-L71S: 2 MB standard, 1 MB safety 1756-L72S: 4 MB standard, 2 MB safety 1756-L73S: 8 MB standard, 4 MB safety 1756-L73SXT: 8 MB standard, 4 MB safety
Network connections, per network module	Not applicable	<ul style="list-style-type: none"> • 1000 class 1 CIP and 528 class 3 CIP; 512 TCP (1756-EN4z) • 256 CIP; 128 TCP (1756-EN2/3z) • 128 CIP; 64 TCP (1756-ENBT) • 128 ControlNet (1756-CN2/B) • 100 ControlNet (1756-CN2/A) • 64 DeviceNet (1756-DNB)
EtherNet/IP nodes supported, max ⁽¹⁾	1756-L81ES, 1756-L81ESK, 1756-L81EXTS, 1756-L81ESXT: 100 nodes 1756-L82ES, 1756-L82ESK, 1756-L82EXTS, 1756-L82ESXT: 175 nodes 1756-L83ES, 1756-L83ESK, 1756-L83EXTS, 1756-L83ESXT: 250 nodes 1756-L84ES, 1756-L84ESK, 1756-L84EXTS, 1756-L84ESXT: 250 nodes 1756-L85ES: 300 nodes	Not applicable
Controller redundancy	When part of a Logix SIS redundancy system	Not supported

(1) A node is an EtherNet/IP device that you add directly to the I/O configuration, and counts toward the node limits of the controller. For more information on EtherNet/IP nodes, see the ControlLogix 5580 and GuardLogix 5580 Controllers User Manual, publication [1756-UM543](#).

For more information regarding the use of safety controllers in a redundant configuration, refer to the Redundancy Systems User Manual, publication [1756-UM015](#).

Armor ControlLogix and Armor GuardLogix On-Machine Controllers

The Armor ControlLogix controller extends the standard ControlLogix platform to the On-Machine space. The Armor GuardLogix controller delivers safety control up to SIL 3, PLe, CAT 4.

With the equivalent of two embedded 1756-EN3TR modules, both offer dual independent Ethernet ports that support a DLR network topology.



Feature	Armor ControlLogix Controllers	Armor GuardLogix Controllers
User Memory	1756-L72EROM: 4 MB 1756-L73EROM: 8 MB	1756-L72EROMS: 4 MB standard, 2 MB safety 1756-L73EROMS: 8 MB, 4 MB safety
Programming languages	Relay ladder Structured Text Function block Sequential Function Chart	Relay ladder

Controller Accessories

1756 Energy Storage Modules

IMPORTANT Energy storage modules apply to only ControlLogix 5570 controllers.

Instead of a battery, the ControlLogix and GuardLogix controllers ship with a 1756-ESMCAP energy storage module (ESM) installed.

Cat No.	Description
1756-ESMCAP	Capacitor-based ESM included with the controller.
1756-ESMNSE	ESM without WallClockTime back-up power. Additionally, you can use this ESM only with a 1756-L73 (8 MB) or smaller memory-sized controller. Use this ESM if your application requires that the installed ESM depletes its residual energy to 40 μ J or less before transporting it into or out of your application.
1756-ESMNRM	ESM that secures the controller by permanently preventing the USB connection and SD card use. This ESM provides your application an enhanced degree of security.

The ControlLogix-XT controller ships with a 1756-ESMNAPXT energy storage module installed.

Cat No.	Description
1756-ESMCAPXT	Capacitor-based ESM included with the controller.
1756-ESMNSEXT	ESM without WallClockTime back-up power. Additionally, you can use this ESM only with a 1756-L73XT (8 MB) or smaller memory-sized controller. Use this ESM if your application requires that the installed ESM depletes its residual energy to 40 μ J or less before transporting it into or out of your application.
1756-ESMNRMXT	ESM that secures the controller by permanently preventing the USB connection and SD card use. This ESM provides your application an enhanced degree of security.

The 1756-L7SP safety partner for a GuardLogix 5570 system has the following modules available.

Cat No.	Description
1756-SPESMNSE	Capacitor-based ESM for a GuardLogix safety partner.
1756-SPESMNRM	ESM for a GuardLogix safety partner that secures the safety partner by permanently preventing the USB connection and SD card use.

Memory Cards

Memory cards offer nonvolatile memory to store a user program and tag data on a controller. The controllers ship with a Secure Digital (SD) card installed in a socket on the controller. Through custom application code in the Logix Designer application, you can manually trigger the controller to save to or load tag data from nonvolatile memory or configure the controller to load from nonvolatile memory on powerup.

Attribute	1784-SD1	1784-SD2	1784-SDHC8	1784-SDHC32
Memory	1 GB	2 GB	8 GB	32 GB
Supported controllers	ControlLogix 5570, GuardLogix 5570, ControlLogix 5580, GuardLogix 5580			
Weight, approx	1.76 g (0.062 oz)			

ControlLogix I/O Modules

The ControlLogix architecture provides a wide range of input and output modules to span many applications, from high-speed digital to process control. The ControlLogix architecture uses a Producer/Consumer model so that input information and output status can be shared among multiple controllers.

Each ControlLogix I/O module mounts in a ControlLogix chassis and **requires** a removable terminal block (RTB) or a 1492 interface module (IFM) to connect all field-side wiring. RTBs and IFMs are not included with the I/O modules. They must be ordered separately.

For detailed specifications, see 1756 ControlLogix I/O Modules Specifications Technical Data, publication [1756-TD002](#).

AC Digital Input Modules

Cat. No.	Inputs/Outputs	Voltage Category	Operating Voltage Range	Removable Terminal Block
1756-IA8D	8 diagnostic inputs (4 points/group)	120V AC	79...132V AC	1756-TBNH 1756-TBSH
1756-IA16	16 inputs (8 points/group)	120V AC	74...132V AC	1756-TBNH 1756-TBSH
1756-IA16I	16 individually isolated inputs	120V AC	74...132V AC	1756-TBCH 1756-TBS6H
1756-IA32	32 inputs (16 points/group)	120V AC	74...132V AC	1756-TBCH 1756-TBS6H
1756-IM16I	16 individually isolated inputs	240V AC	159...265V AC	1756-TBCH 1756-TBS6H
1756-IN16	16 inputs (8 points/group)	24V AC	10...30V AC	1756-TBNH 1756-TBSH

AC Digital Output Modules

Cat. No.	Inputs/Outputs	Voltage Category	Operating Voltage Range	Removable Terminal Block
1756-OA8	8 outputs (4 points/group)	120/240V AC	79...265V AC	1756-TBNH 1756-TBSH
1756-OA8D	8 diagnostic, electronically fused outputs (4 points/group)	120V AC	74...132V AC	1756-TBNH 1756-TBSH
1756-OA8E	8 electronically fused outputs (4 points/group)	120V AC	74...132V AC	1756-TBNH 1756-TBSH
1756-OA16	16 mechanically fused/group outputs (8 points/group)	120/240V AC	74...265V AC	1756-TBNH 1756-TBSH
1756-OA16I	16 individually isolated outputs	120/240V AC	74...265V AC	1756-TBCH 1756-TBS6H
1756-ON8	8 outputs (4 points/group)	24V AC	10...30V AC, current > 50 mA 16...30V AC, current < 50 mA	1756-TBNH 1756-TBSH

DC Digital Input Modules

Cat. No.	Inputs/Outputs	Voltage Category	Operating Voltage Range	Removable Terminal Block
1756-IB16	16 inputs (8 points/group)	12/24V DC sink	10...31.2V DC	1756-TBNH 1756-TBSH
1756-IB16XT	16 inputs (8 points/group)	12/24V DC sink	10...31.2V DC	1756-TBNHXT 1756-TBSHXT
1756-IB16D	16 diagnostic inputs (4 points/group)	12/24V DC sink	10...30V DC	1756-TBCH 1756-TBS6H
1756-IB16I	16 individually isolated inputs	12/24V DC sink/source	10...30V DC	1756-TBCH 1756-TBS6H
1756-IB16IF	16 high-speed, individually isolated inputs	12/24V DC sink/source	10...30V DC	1756-TBCH 1756-TBS6H
1756-IB16ISOE	16 individually isolated, sequence of events inputs	24/48V DC sink/source	10...55V DC	1756-TBCH 1756-TBS6H
1756-IB32	32 inputs (16 points/group)	12/24V DC sink	10...31.2V DC	1756-TBCH 1756-TBS6H
1756-IB32XT	32 inputs (16 points/group)	12/24V DC sink	10...31.2V DC	1756-TBCHXT 1756-TBS6HXT
1756-IC16	16 inputs (8 points/group)	48V DC sink	30...55V DC @ 60 °C (140 °F) 30...60V DC @ 55 °C (131 °F)	1756-TBNH 1756-TBSH
1756-IG16	16 inputs (8 points/group)	5V DC TTL source (Low = True)	4.5...5.5V DC	1756-TBNH 1756-TBSH
1756-IH16I	16 individually isolated inputs	125V DC sink/source	90...146V DC	1756-TBCH 1756-TBS6H
1756-IH16ISOE	16 individually isolated, sequence of events inputs	125V DC sink/source	90...140V DC	1756-TBCH 1756-TBS6H
1756-IV16	16 inputs (8 points/group)	12/24V DC source	10...30V DC	1756-TBNH 1756-TBSH
1756-IV32	32 inputs (16 points/group)	12/24V DC source	10...30V DC	1756-TBCH 1756-TBS6H

DC Digital Output Modules

Cat. No.	Inputs/Outputs	Voltage Category	Operating Voltage Range	Removable Terminal Block
1756-OB8	8 outputs	12/24V DC source	10...30V DC	1756-TBNH 1756-TBSH
1756-OB8EI	8 electronically fused, individually isolated outputs	12/24V DC source	10...30V DC	1756-TBCH 1756-TBS6H
1756-OB16D	16 diagnostic outputs (8 points/group)	24V DC source	19.2...30V DC	1756-TBCH 1756-TBS6H
1756-OB16E	16 electronically fused outputs (8 points/group)	12/24V DC source	10...31.2V DC	1756-TBNH 1756-TBSH
1756-OB16I	16 individually isolated outputs	12/24V DC sink/source	10...30V DC	1756-TBCH 1756-TBS6H
1756-OB16IEF	16 high-speed, individually isolated, electronically fused outputs	24V DC sink/source	10...30V DC	1756-TBCH 1756-TBS6H
1756-OB16IEFS	16 scheduled, high-speed, individually isolated, electronically-fused outputs	24V DC sink/source	10...30V DC	1756-TBCH 1756-TBS6H
1756-OB16IS	16 individually isolated outputs 8 scheduled outputs	12/24V DC sink/source	10...30V DC	1756-TBCH 1756-TBS6H
1756-OB32	32 outputs (16 points/group)	12/24V DC source	10...31.2V DC	1756-TBCH 1756-TBS6H
1756-OB32XT	32 outputs (16 points/group)	12/24V DC source	10...31.2V DC	1756-TBCHXT 1756-TBS6HXT
1756-OC8	8 outputs (4 points/group)	48V DC source	30...60V DC	1756-TBNH 1756-TBSH
1756-OG16	16 (8 points/group)	5V DC TTL source (Low=True)	4.5...5.5V DC	1756-TBNH 1756-TBSH
1756-OH8I	8 individually isolated outputs	120V DC	90...146V DC	1756-TBCH 1756-TBS6H
1756-OV16E	16 electronically fused outputs (8 points/group)	12/24V DC sink	10...30V DC	1756-TBNH 1756-TBSH
1756-OV32E	32 electronically fused outputs (16 points/group)	12/24V DC sink	10...30V DC	1756-TBCH 1756-TBS6H

DC Digital Safety Modules

Cat. No.	Inputs/Outputs	Voltage Category	Operating Voltage Range	Removable Terminal Block
1756-IB16S	16 channels (1 group of 16), sinking	12/24V DC sink	10...32V AC	1756-TBCHS 1756-TBS6HS
1756-OBV8S	8 outputs	24V DC source	18...32V DC	1756-TBNHS 1756-TBSHS

IMPORTANT

- 1756-IB16S and 1756-OBV8S modules are only compatible with GuardLogix 5580 controllers as local or remote I/O, and Compact GuardLogix 5380 controllers as remote I/O.
- The 1756-IB16S and 1756-OBV8S modules are only compatible with a 1756 ControlLogix Chassis, Series C.

Contact Output Modules

Cat. No.	Inputs/Outputs	Operating Voltage Range	Removable Terminal Block
1756-OW16I	16 normally open, individually isolated outputs	5...125V DC 10...240V AC	1756-TBCH 1756-TBS6H
1756-OX8I	8 normally open 8 normally closed, individually isolated outputs (2 points/group)	5...125V DC 10...240V AC	1756-TBCH 1756-TBS6H

Analog Input Modules

Cat. No.	Inputs/Outputs	Range	Resolution	Removable Terminal Block
1756-IF8	8 single-ended inputs 4 differential inputs 2 high-speed differential inputs	$\pm 10V$ 0...10V 0...5V 0...20 mA	$\pm 10.25V$: 320 μV /count (15 bits plus sign bipolar) 0...10.25V: 160 μV /count (16 bits) 0...5.125V: 80 μV /count (16 bits) 0...20.5 mA: 0.32 μA /count (16 bits)	1756-TBCH 1756-TBS6H
1756-IF8I	8 individually isolated inputs, current or voltage	$\pm 10V$ 0...10V 0...5V 0...20 mA	24 bits $\pm 10.5V$ (1.49 μV /count) 0...10.5V (1.49 μV /count) 0...5.25V (1.49 μV /count) 0...21 mA (2.99 nA/count)	1756-TBCH 1756-TBS6H
1756-IF16	16 single-ended inputs 8 differential or 4 differential (high speed) inputs	$\pm 10V$ 0...10V 0...5V 0...20 mA	16 bits $\pm 10.25V$: 320 μV /count (15 bits plus sign bipolar) 0...10.25V: 160 μV /count (16 bits) 0...5.125V: 80 μV /count (16 bits) 0...20.5 mA: 0.32 μA /count (16 bits)	1756-TBCH 1756-TBS6H

Analog RTD and Thermocouple Modules

Cat. No.	Inputs/Outputs	Range	Resolution	Removable Terminal Block
1756-IRT8I	8 individually isolated inputs, RTD or thermocouple inputs (2 CJC)	1...500 Ω 2...1000 Ω 4...2000 Ω 8...4000 Ω -100...+100 mV	24 bits 0...510 Ω : 0.06 m Ω /count 0...1020 Ω : 0.12 m Ω /count 0...2040 Ω : 0.25 m Ω /count 0...4080 Ω : 0.50 m Ω /count -101...+101 mV: 0.01 μV /count	1756-TBCH 1756-TBS6H
1756-IRT12	12 channels RTD mode	1...500 Ω 2...1000 Ω 4...2000 Ω 8...4000 Ω	24 bits 0...510 Ω : 0.06 m Ω /count 0...1020 Ω : 0.12 m Ω /count 0...2040 Ω : 0.25 m Ω /count 0...4080 Ω : 0.50 m Ω /count	1756-TBCH 1756-TBS6H
1756-IT16	16 channels, thermocouple mode 2 CJC	-100...+100 mV	24 bits -101...+101 mV: 0.01 μV /count	1756-TBCH 1756-TBS6H

Analog Output Modules

Cat. No.	Inputs/Outputs	Range	Resolution	Removable Terminal Block
1756-OF4	4 voltage or current outputs	$\pm 10V$ 0...20 mA	15 bits across 10.5V - 320 μV /bit 16 bits across 21 mA - 325 nA/bit	1756-TBNH 1756-TBSH
1756-OF8	8 voltage or current outputs	$\pm 10V$ 0...20 mA	15 bits across 10.5V - 320 μV /bit 16 bits across 21 mA - 325 nA/bit	1756-TBNH 1756-TBSH
1756-OF8I	8 individually isolated outputs, current or voltage	$\pm 10V$ 0...10V 0...5V 0...20 mA	16 bit $\pm 10.5V$ (0.32 mV/count) 0...10.5V (0.16 mV/count) 0...5.25V (0.08 mV/count) 0...21 mA (0.32 μA /count)	1756-TBCH 1756-TBS6H

Analog Combination Input and Output Module

Cat. No.	Inputs/Outputs	Range	Resolution	Removable Terminal Block
1756-IF4FXOF2F	4 high-speed, submillisecond, differential inputs 2 high-speed voltage or current outputs	Input: $\pm 10V$ 0...10V 0...5V 0...20 mA	Input: Approx 14 bits across $\pm 10V$ DC (21V total) $\pm 10V$: 1.3 mV/bit, 14-bit effective 0...10.5V: 1.3 mV/bit, 13-bit effective 0...5.25V: 1.3 mV/bit, 12-bit effective Approx 12 bits across 21 mA 0...21 mA: 5.25 μA /bit	1756-TBCH 1756-TBS6H
		Output: $\pm 10V$ 0...20 mA	Output: 13 bits across 21 mA = 2.8 μA /bit 14 bits across 21.8V = 1.3 mV/bit	

HART I/O Modules

HART (Highway Addressable Remote Transducer) is an open protocol designed to connect analog devices. HART I/O modules offer:

- Analog and HART connectivity in one module
- No external hardware is required to access HART signal
- HART commands can be transmitted as unscheduled messages
- Supports asset management software to HART devices

Cat. No.	Inputs/Outputs	Range	Resolution	Removable Terminal Block
1756-IF8H	8 differential voltage or current inputs, HART interface	±10V 0...5V 0...10V 0...20 mA 4...20 mA	16...21 bits	1756-TBCH 1756-TBS6H
1756-IF8IH	8 individually isolated current inputs, HART interface	0...20 mA 4...20 mA	16...21 bits	1756-TBCH 1756-TBS6H
1756-IF16H	16 differential current inputs, HART interface	0...20 mA 4...20 mA	16...21 bits	1756-TBCH 1756-TBS6H
1756-IF16IH	16 individually isolated current inputs, HART interface	0...20 mA 4...20 mA	16...21 bits	1756-TBCH 1756-TBS6H
1756-OF8H	8 voltage or current outputs, HART interface	±10V 0...20 mA 4...20 mA	15...16 bits	1756-TBNH 1756-TBSH
1756-OF8IH	8 individually isolated current outputs, HART interface	0...20 mA 4...20 mA	15 bits across 24 mA, 732 nA per bit	1756-TBCH 1756-TBS6H

Specialty I/O Modules

Cat. No.	Inputs/Outputs	Description	Removable Terminal Block
1756-CFM	4 inputs (2 per channel) 2 outputs, current sourcing	Configurable flowmeter module 2 Flowmeter (F) inputs used for all modes 2 Gate inputs used in Totalizer mode for prover/store count	1756-TBNH 1756-TBSH
1756-HSC	2 counters, each with 3 inputs (A, B, Z for gate/reset) 4 outputs (2 points/group)	High-speed counter module 5V operation: 4.5...5.5V DC 12/24V operation: 10...26.4V DC	1756-TBCH 1756-TBS6H
1756-LSC8XIB8I	8...24V DC counters 8 individually isolated, standard inputs, or counters	Low-speed counter module 8...40 kHz 24V DC counters 8 individually isolated 12/24V DC low speed (max frequency 40 kHz) counters 8 individually isolated high-speed 12/24V DC sink/source standard- or counter-control inputs	1756-TBCH 1756-TBS6H
1756-PLS	Left section: 2 groups of 4 outputs and 4 inputs each Center section: resolver interface and I/O control Right section: 2 groups of 4 outputs and 4 inputs each	Programmable limit switch module	Requires 3 RTBs: 1756-TBNH or 1756-TBSH

Accessories - I/O Modules

1756 Removable Terminal Blocks

Removable terminal blocks (RTBs) provide a flexible interconnection between your plant wiring and 1756 I/O modules. The RTB plugs into the front of the I/O module. The type of module determines the RTB that you need. You can choose screw-clamp or spring-clamp RTBs.



RTBs are not shipped with I/O modules. You must order them separately.

The standard housing on the front of the wiring arm is not necessarily deep enough for 2.5 mm² (14 AWG) wiring. If you plan to use 2.5 mm² (14 AWG) wiring, also order the extended housing. For more information on Extended-Depth Housing, see Knowledgebase Technote [Use of the 1756-TBE Extended Terminal Housing](#).

Attribute	1756-TBNH 1756-TBNHS 1756-TBNHXT	1756-TBSH 1756-TBSHS 1756-TBSHXT	1756-TBCH 1756-TBCHS 1756-TBCHXT	1756-TBS6H 1756-TBS6HS 1756-TBS6HXT	1756-TBE 1756-TBES 1756-TBEXT
Description	20-position NEMA screw-clamp removable block	20-pin spring-clamp removable terminal block with standard housing	36-pin cage-clamp removable terminal block with standard housing	36-pin spring-clamp removable terminal block with standard housing	Extended-depth terminal block housing
Screw torque	0.8...1 N•m 7...9 lb•in		0.4 N•m 4.4 lb•in		Not applicable

Wiring Systems

As an alternative to buying RTBs and connecting the wires yourself, you can buy a wiring system of the following:

- Interface modules (IFMs) that provide the I/O terminal blocks for Digital I/O modules. Use the prewired cables that match the I/O module to the IFM.
- Analog interface modules (AIFMs) that provide the I/O terminal blocks for analog I/O modules. Use the prewired cables that match the I/O module to the AIFM.
- I/O module-ready cables. One end of the cable assembly is an RTB that plugs into the front of the I/O module. The other end has individually color-coded conductors that connect to a standard terminal block.

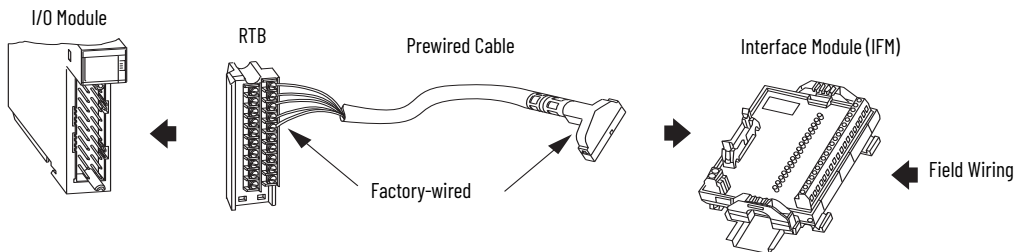

ControlLogix Compute Modules

ControlLogix Compute modules are chassis-based modules that let you communicate directly with a ControlLogix controller via the system backplane and over a network. The presence of a ControlLogix Compute module is similar to installing a security hardened computer in a ControlLogix chassis.

- 1756 ControlLogix Compute Modules are Industrial PCs with Windows® and Linux Operating Systems, and C++ backplane API for custom applications.
- 1756 Embedded Edge Compute Module is an Embedded Edge Computing device shipped with FactoryTalk® Optix Studio™ and FactoryTalk® Remote Access™ to enable IT/OT convergence via web-based content and alternative communications at the Logix level.

Example Configuration - Control Systems with Compute Module

Compute Module Communication Over Backplane

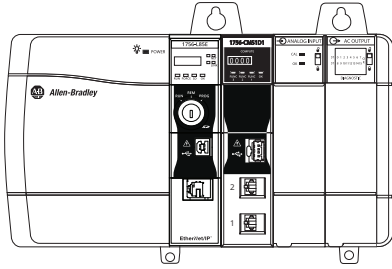

- ControlLogix Controller
- ControlLogix Compute Module
- ControlLogix I/O Modules

Compute Module Communication Over EtherNet/IP Network and Controller Chassis Backplane

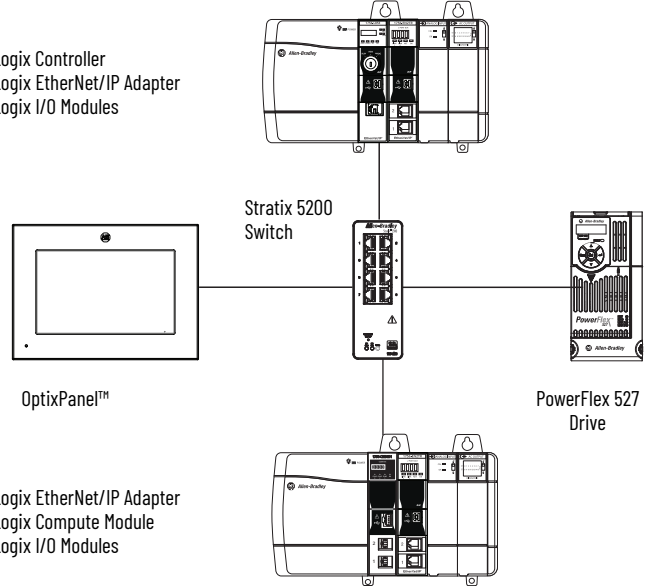

- ControlLogix Controller
- ControlLogix EtherNet/IP Adapter
- ControlLogix I/O Modules

- ControlLogix EtherNet/IP Adapter
- ControlLogix Compute Module
- ControlLogix I/O Modules

Cat. Nos	Description	Application Support	Compatible Controllers
1756-CMS1B1	Compute module with: <ul style="list-style-type: none"> • Standard performance (dual-core CPU) • 32 GB SSD • Embedded Windows 10 IoT Enterprise LTSC 64-bit OS 	Pre-loaded application not included C++ backplane API for custom applications	ControlLogix 5580 ControlLogix 5570 ControlLogix 5560 ControlLogix 5550
1756-CMS1C1	Compute module with: <ul style="list-style-type: none"> • Standard performance (dual-core CPU) • 32 GB SSD • Embedded Linux Debian 32-bit OS 		
1756-CMS1D1	Compute module with: <ul style="list-style-type: none"> • Standard performance (dual-core CPU) • 32 GB SSD • Embedded Linux Debian 64-bit OS 		
1756-CMS1H1	Compute module with: <ul style="list-style-type: none"> • Standard performance (dual-core CPU) • 32 GB SSD • Embedded Linux Red Hat 64-bit OS 		
1756-CMEE1Y1	Embedded Edge Compute module with: <ul style="list-style-type: none"> • Embedded Edge performance (quad-core CPU) • 32 GB microSD™ card and 20 GB eMMC memory • Embedded Linux Yocto 64-bit OS 	Pre-loaded with FactoryTalk® Optix™ XS and FactoryTalk Remote Access Runtime Pro	

ControlLogix Communication Modules

Separate communication modules are available for different networks. Install multiple communication modules into the ControlLogix backplane to bridge or route control and information data between networks. You can route a message through a maximum of four chassis (eight communication hops). You do not need a ControlLogix controller in the chassis.

Application	Network	Page
<ul style="list-style-type: none"> Plant management (material handling) Configuration, data collection, and control on one high-speed network Time-critical applications with no established schedule Inclusion of commercial technologies (such as video over IP) Internet/Intranet connection High-speed transfer of time-critical data between controllers and I/O devices Integrated motion on the EtherNet/IP network and safety Redundant controller systems 	EtherNet/IP	21
<ul style="list-style-type: none"> High-speed transfer of time-critical data between controllers and I/O devices Media redundancy ControlLogix 5570 redundant controller systems 	ControlNet	22
<ul style="list-style-type: none"> Connections of low-level devices directly to plant floor controllers, without interfacing them through I/O modules Data sent as needed More diagnostics for improved data collection and fault detection Less wiring and reduced start-up time than a traditional, hard-wired system 	DeviceNet	22
<ul style="list-style-type: none"> Connections between controllers and I/O adapters Data sent regularly Distributed control so that each controller has its own I/O and communicates with a supervisory controller 	Remote I/O	22

For detailed specifications, see the 1756 ControlLogix Communication Modules Specifications Technical Data, publication [1756-TD003](#).

For ControlNet migration guidelines, see the ControlNet to EtherNet/IP Migration Reference Manual, publication [CNET-RM001](#).

EtherNet/IP Communication Modules

EtherNet/IP (Ethernet Industrial Protocol) is an open industrial-networking standard that supports real-time I/O messaging and message exchange. The EtherNet/IP network uses off-the-shelf Ethernet communication chips and physical media.

Cat. No.	Description	Media	Communication Rate	Integrated Motion on the EtherNet/IP Network Axes, max	TCP/IP Connections	Logix Connections
1756-EN2F	EtherNet/IP bridge, fiber	Fiber	100 Mbps	8	128	256
1756-EN2T	EtherNet/IP bridge, copper	Copper	10/100 Mbps	8	128	256
1756-EN2TXT	ControlLogix-XT extended temperature EtherNet/IP bridge for harsh environments, copper	Copper	10/100 Mbps	8	128	256
1756-EN2TP	EtherNet/IP bridge, copper	Dual copper	10/100 Mbps	8	128	256
1756-EN2TPXT	ControlLogix-XT extended temperature EtherNet/IP bridge for harsh environments, copper	Dual copper	10/100 Mbps	8	128	256
1756-EN2TR	EtherNet/IP bridge, embedded switch, copper	Dual copper	10/100 Mbps	8	128	256
1756-EN2TRXT	ControlLogix-XT extended temperature EtherNet/IP bridge for harsh environments, embedded switch, copper	Dual copper	10/100 Mbps	8	128	256
1756-EN3TR	EtherNet/IP bridge, embedded switch, copper	Dual copper	10/100 Mbps	128	128	256
1756-EN4TR	EtherNet/IP bridge with CIP Security™, embedded switch, copper	Dual copper	10/100 Mbps, 1 Gbps	256	512	1000 I/O 528 Messaging
1756-EN4TRXT	ControlLogix-XT EtherNet/IP bridge for harsh environments, CIP Security, embedded switch, copper	Dual copper	10/100 Mbps, 1 Gbps	256	512	1000 I/O 528 Messaging
1756-ENBT	EtherNet/IP bridge, copper	Copper	10/100 Mbps	—	64	128

ControlNet Communication Modules

For ControlNet migration guidelines, see the ControlNet to EtherNet/IP Migration Reference Manual, publication [CNET-RM001](#).

The ControlNet network combines the functionality of an I/O network and a peer-to-peer network, providing high-speed performance. The ControlNet network provides deterministic, repeatable transfers of critical control data.

Cat. No.	Description	Communication Rate	Logix Connections	Number of Nodes
1756-CN2	ControlNet bridge, standard media	5 Mbps	128 ⁽¹⁾	99
1756-CN2R	ControlNet bridge, redundant media	5 Mbps	128 ⁽¹⁾	99
1756-CN2RXT	ControlLogix-XT, harsh environment, ControlNet bridge, redundant media	5 Mbps	128 ⁽¹⁾	99

(1) 128 connections are available for standard use. An extra three connections are reserved for redundant control.

DeviceNet Communication Module

The DeviceNet network provides connections between simple, industrial devices (such as sensors and actuators) and higher-level devices (such as controllers and computers).

Cat. No.	Description	Communication Rate	Number of Nodes
1756-DNB	DeviceNet bridge	125 Kbps (500 m max) 250 Kbps (250 m max) 500 Kbps (100 m max)	64

Other Connectivity Options

Option	Consideration
USB connection	The ControlLogix controllers have a USB port in place of the serial port. ⁽¹⁾ If your application requires RS-232 functionality, see the many Encompass™ partner products at https://www.rockwellautomation.com/encompass .
SynchLink network	The SynchLink communication module (1756-SYNCH) provides time synchronization and data broadcasting capabilities for distributed motion and coordinated drive control. The module connects a ControlLogix chassis to a SynchLink fiber-optic communication link.

(1) The USB port is intended only for temporary local programming purposes and not intended for permanent connection. Do not use the USB port in hazardous locations.

For web server migration options, see the EtherNet/IP Web Server Module Migration Reference Manual, publication [1756-RM013](#).

Modbus Support

To access a Modbus TCP network, use one of the following methods:

- Connect through 1756 EtherNet/IP communication modules, with firmware revision 5.007 or later, and execute a ladder-logic routine.
- Connect through the 5069-SERIAL module, with firmware revision 2.011 or later and execute a ladder-logic routine.

For more information, see Knowledgebase Technote [Sample Code for Modbus TCP Server and Client Applications](#).

To access a Modbus RTU network, connect through the serial port (if available) and execute a ladder-logic routine. For more information, see Using Logix 5000 Controllers as Masters or Slaves on Modbus Application Solution, publication [CIG-AP129](#).

ControlLogix Integrated Motion

The Logix architecture supports motion control components that work in a wide variety of machine architectures:

- Integrated motion on the EtherNet/IP network supports a connection to Ethernet drives.
- The Kinetix® integrated-motion solution uses a SERCOS or EtherNet/IP interface to perform multi-axis, synchronized motion.
- Logix integrated motion supports the analog family of servo modules for controlling drives/actuators.
- Networked motion provides connection via the DeviceNet network to one axis drive to perform point-to-point indexing.

For detailed specifications on motion interface modules, see the 1756 ControlLogix Integrated Motion Modules Specifications Technical Data, publication [1756-TD004](#).

For more information, see:

- FactoryTalk Motion Analyzer at <https://motionanalyzer.rockwellautomation.com/>
- Kinetix Motion Control Selection Guide, publication [GMC-SG001](#), to verify drive, motor, and accessory specifications

Integrated Motion on an EtherNet/IP Network

Product	Consideration
Drive that supports EtherNet/IP connections	Unlimited velocity, torque, and VHz configured drives: <ul style="list-style-type: none"> • Kinetix 6500 drives • Kinetix 5700 drives • Kinetix 5500 drives • Kinetix 350 drives • PowerFlex 755 drives • PowerFlex 527 drives
ControlLogix controller	<ul style="list-style-type: none"> • ControlLogix 5570 controller: 128 axes • ControlLogix 5580 controller: 256 axes
ControlLogix EtherNet/IP communication module	<ul style="list-style-type: none"> • 1...8 position loop axes that are configured with the 1756-EN2T or 1756-EN2TR modules • 1...128 position loop axes that are configured with the 1756-EN3TR module • 1...256 position loop axes that are configured with the 1756-EN4TR module

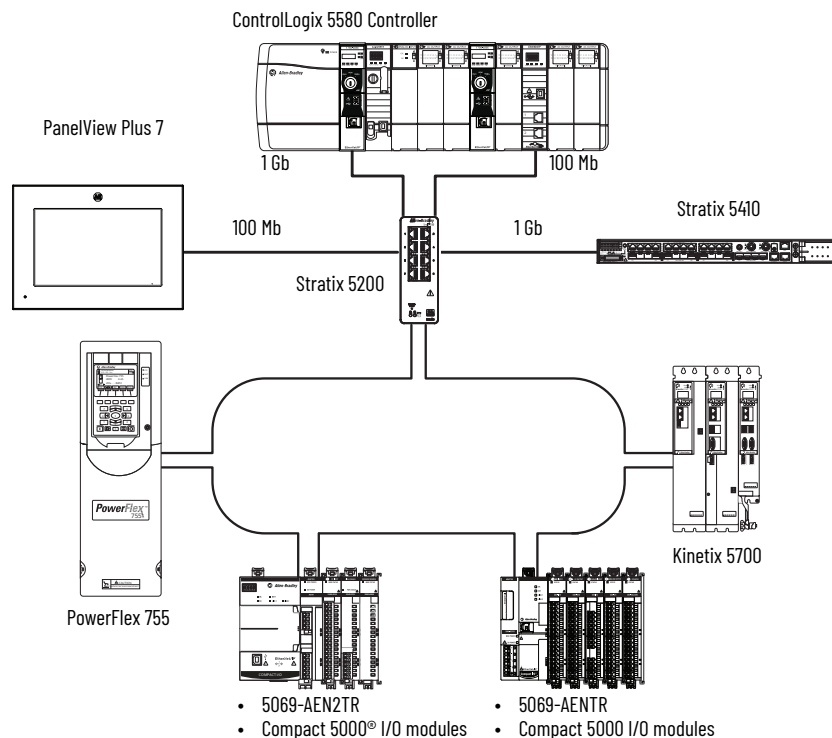

ControlLogix Chassis

The ControlLogix system is a modular system that requires a 1756 I/O chassis. Place any module into any slot. The backplane provides a high-speed communication path between modules.

The chassis are designed for horizontal-only, back-panel mounting. The chassis are available in these options:

- Standard chassis
- ControlLogix-XT chassis
- ControlLogix-ZXT chassis

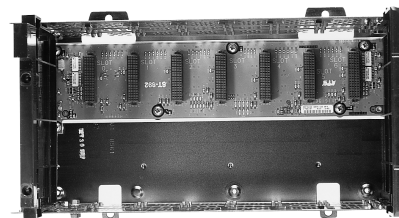

For detailed specifications, see the 1756 ControlLogix Chassis Specifications Technical Data, publication [1756-TD006](#).

Standard Chassis

The chassis backplane provides a high-speed communication path between modules and distributes power to each of the modules within the chassis.

Cat. No.	Description	Slots
1756-A4	Standard chassis	4
1756-A7		7
1756-A10		10
1756-A13		13
1756-A17		17

ControlLogix-XT Chassis

The ControlLogix-XT chassis support extreme temperature environments. Series C XT chassis are conformally coated for increased survivability in ISA G3 environments. ControlLogix-ZXT chassis are conformally coated to resist corrosion in ISA GX environments.

Cat. No.	Description	Slots	Temperature Range
1756-A7XT/C	ControlLogix-XT chassis	7	-25...+70 °C (-13...+158 °F)
1756-A10XT/C		10	
1756-A7ZXT		7	
1756-A10ZXT		10	

Accessories - Chassis

Use a slot filler module to fill empty slots.

Cat. No.	Description
1756-N2	Slot filler module for empty slots in standard ControlLogix chassis
1756-N2XT	Slot filler module for empty slots in ControlLogix-XT chassis

ControlLogix Power Supplies

ControlLogix power supplies are used with the 1756 chassis to provide 1.2V, 3.3V, 5V, and 24V DC power directly to the chassis backplane. Select from these configurations:

- Standard power supplies
- ControlLogix-XT power supplies
- Redundant power supplies

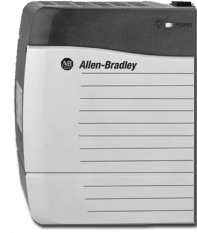

For detailed specifications, see the 1756 ControlLogix Power Supplies Specifications Technical Data, publication [1756-TD005](#).

IMPORTANT Make sure not to exceed the power supply capacity on any of the voltage/current limits by taking into account the modules that are used in the chassis. For additional information, see the Knowledgebase Technote [Sizing the ControlLogix Power Supply](#).

Standard Power Supplies

You mount a standard power supply directly on the left end of the chassis, where it plugs directly into the backplane.

Cat. No.	Description	Voltage Category	Operating Voltage Range	Chassis
1756-PA50	Slim AC power supply	120V/240V AC	85...265V AC	Standard, series A
1756-PA72	Standard AC power supply	120V/240V AC	85...265V AC	Standard, series A and series B
1756-PA75		120V/240V AC	85...265V AC	Standard, series B
1756-PB50	Slim DC power supply	24V DC	18...32V DC	Standard, series A
1756-PB72	Standard DC power supply	24V DC	18...32V DC	Standard, series A and series B
1756-PB75		24V DC	18...32V DC	Standard, series B
1756-PC75		48V DC	30...60V DC	Standard, series B
1756-PH75		125V DC	90...143V DC	Standard, series B

ControlLogix-XT Power Supplies

The ControlLogix-XT power supplies support harsh environments.

Cat. No.	Description	Voltage Category	Operating Voltage Range	Chassis
1756-PAXT	ControlLogix-XT AC power supply	120V/240V AC	85...265V AC	XT
1756-PA30XT	ControlLogix-XT slim AC power supply	120V/240V AC	85...265V AC	
1756-PBXT	ControlLogix-XT DC power supply	24V DC	18...32V DC	
1756-PB30XT	ControlLogix-XT slim DC power supply	24V DC	18...32V DC	

Redundant Power Supplies

A redundant power supply system provides extra uptime protection for chassis that are used in critical applications. The redundant power supplies funnel power through the chassis adapter to the ControlLogix series B chassis backplane. To build a redundant power supply system, you need the following components.

Cat. No.	Amount	Description	Voltage Category	Operating Voltage Range	Chassis
1756-PAR2	Kit	Bundled system contains: • Two 1756-PA75R power supplies • Two 1756-CPR2 cables • One 1756-PSCA2 chassis adapter	110V AC	—	Standard, series B
1756-PAR2XT	Kit	Bundled system contains: • Two 1756-PAXTR power supplies • Two 1756-CPR2 cables • One 1756-PSCA2 chassis adapter	110V AC	—	
1756-PBR2	Kit	Bundled system contains: • Two 1756-PB75R power supplies • Two 1756-CPR2 cables • One 1756-PSCA2 chassis adapter	24V DC	—	
1756-PBR2XT	Kit	Bundled system contains: • Two 1756-PBXTR power supplies • Two 1756-CPR2 cables • One 1756-PSCA2 chassis adapter	24V DC	—	
1756-PA75R/A or 1756-PAXTR	2	Redundant AC power supply	120V/240V AC	85...265V AC	
1756-PB75R/A or 1756-PBXTR	2	Redundant DC power supply	24V DC	18...32V DC	
1756-CPR2 or 1756-CPR2D or 1756-CPR2U	2	Redundant power supply cable: • Connector angle = straight, length = 0.91 m (3 ft) • Connector angle = down, length = 0.91 m (3 ft) • Connector angle = up, length = 0.91 m (3 ft)	—	—	
1756-PSCA2 or 1756-PSCA2XT	1	Redundant power supply chassis adapter			
N/A (user-supplied)	2	Annunciator wiring ⁽¹⁾ (Maximum length = 10 m [32.8 ft])			

(1) Optional user-supplied annunciator wiring can be connected to the solid-state relay input for status and troubleshooting purposes.

Additional Resources

These documents contain additional information concerning related products from Rockwell Automation. You can view or download publications at rok.auto/literature.

Resource	Description
ControlLogix 5580 and GuardLogix 5580 Controllers User Manual, publication 1756-UM543	Provides information about designing a system, operating a ControlLogix or GuardLogix-based controller system, and developing applications.
Redundancy Systems User Manual, publication 1756-UM015	Provides information about how to set up, configure, program, monitor, and troubleshoot high availability systems that use Logix SIS, ControlLogix 5580, or ControlLogix 5570 redundancy.
ControlLogix 5570/5560 Redundancy User Manual, publication 1756-UM535	Provides information to install, configure, and use ControlLogix 5570/5560 redundancy systems.
Using ControlLogix in SIL2 Applications Safety Reference Manual, publication 1756-RM001	Provides specific configuration and programming considerations.
GuardLogix 5580 and Compact GuardLogix 5380 Controller Systems Safety Reference Manual, publication 1756-RM012	Contains detailed requirements for achieving and maintaining SIL 2/PLd and SIL 3/PLe with the GuardLogix 5580 controller system, using the Studio 5000 Logix Designer application.
Logix SIS in SIL 2/3 Safety Applications Reference Manual, publication 1756-RM015	Describes Logix SIS systems, which are type-approved and certified for use in safety applications.
1756 ControlLogix Controllers Technical Data, publication 1756-TD001	Provides specifications for ControlLogix controllers.
1756 ControlLogix I/O Specifications Technical Data, publication 1756-TD002	Provides specifications for ControlLogix I/O modules.
1756 ControlLogix Communications Modules Specifications Technical Data, publication 1756-TD003	Provides specifications for ControlLogix Communications Modules.
1756 ControlLogix Integrated Motion Modules Specifications Technical Data, publication 1756-TD004	Provides specifications for ControlLogix Integrated Motion Modules.
1756 ControlLogix Power Supplies Specifications Technical Data, publication 1756-TD005	Provides specifications for ControlLogix Power Supplies.
1756 ControlLogix Chassis Specifications Technical Data, publication 1756-TD006	Provides specifications for ControlLogix Chassis.
AADvance Controller Safety Manual, publication ICSTT-RM446	Defines how to safely apply AADvance controllers for a Safety Instrumented Function. It sets out standards (which are mandatory) and makes recommendations to make sure that installations satisfy and maintain their required safety integrity level.
Industrial Automation Wiring and Grounding Guidelines, publication 1770-4.1	Provides general guidelines for installing a Rockwell Automation industrial system.
Product Certifications website, rok.auto/certifications	Provides declarations of conformity, certificates, and other certification details.

Rockwell Automation Support

Use these resources to access support information.

Technical Support Center	Find help with how-to videos, FAQs, chat, user forums, Knowledgebase, and product notification updates.	rok.auto/support
Local Technical Support Phone Numbers	Locate the telephone number for your country.	rok.auto/phonesupport
Technical Documentation Center	Quickly access and download technical specifications, installation instructions, and user manuals.	rok.auto/techdocs
Literature Library	Find installation instructions, manuals, brochures, and technical data publications.	rok.auto/literature
Product Compatibility and Download Center (PCDC)	Download firmware, associated files (such as AOP, EDS, and DTM), and access product release notes.	rok.auto/pcdc

Documentation Feedback

Your comments help us serve your documentation needs better. If you have any suggestions on how to improve our content, complete the form at rok.auto/docfeedback.

AADvance, Allen-Bradley, Armor, ArmorBlock, ArmorPOINT, ArmorStart, ArmorStratix, Compact 5000, ControlLogix, ControlLogix-XT, Dynamix, expanding human possibility, Encompass, FactoryTalk, FactoryTalk Optix Studio, FLEX Ex, FLEX 5000, Guard I/O, GuardLogix, GuardLogix-XT, Integrated Architecture, Kinetix, Logix 5000, On-Machine, OptixPanel, PanelView, PartnerNetwork, PlantPAx, POINT Guard I/O, POINT I/O, PowerFlex, PowerMonitor, Rockwell Automation, Stratix, Studio 5000, Studio 5000 Logix Designer, and SynchLink are trademarks of Rockwell Automation, Inc.

CIP, CIP Security, ControlNet, DeviceNet, and EtherNet/IP are trademarks of ODVA, Inc.





microSD is a trademark of SD-3C.

Windows is a trademark of Microsoft Corporation.

Trademarks not belonging to Rockwell Automation are property of their respective companies.

Rockwell Automation maintains current product environmental compliance information on its website at rok.auto/pec.

Rockwell Otomasyon Ticaret A.Ş. Kar Plaza İş Merkezi E Blok Kat:6 34752, İçerenköy, İstanbul, Tel: +90 (216) 5698400 EEE Yönetmeliğine Uygundur

Connect with us.    

rockwellautomation.com ————— **expanding human possibility®**

AMERICAS: Rockwell Automation, 1201 South Second Street, Milwaukee, WI 53204-2496 USA, Tel: (1) 414.382.2000

EUROPE/MIDDLE EAST/AFRICA: Rockwell Automation NV, Pegasus Park, De Kleetlaan 12a, 1831 Diegem, Belgium, Tel: (32) 2663 0600

ASIA PACIFIC: Rockwell Automation SEA Pte Ltd, 2 Corporation Road, #04-05, Main Lobby, Corporation Place, Singapore 618494, Tel: (65) 6510 6608

UNITED KINGDOM: Rockwell Automation Ltd., Pitfield, Kiln Farm, Milton Keynes, MK11 3DR, United Kingdom, Tel: (44)(1908) 838-800

Publication 1756-SG002C-EN-P - January 2025

Supersedes Publication 1756-SG002B-EN-P - May 2024

Copyright © 2025 Rockwell Automation, Inc. All rights reserved. Printed in the U.S.A.