

Rockwell Automation Library of Process Objects: Analog Fanout (P_Fanout)

Version 3.5

IMPORTANT

This manual applies to the Rockwell Automation Library of Process Objects version 3.5 or earlier.
For Rockwell Automation Library of Process Objects version 5.0, see

- [PROCES-RM200](#)

For Rockwell Automation Library of Process Objects version 4.0 or later, use the following manuals:

- [PROCES-RM013](#) contains logic instructions
- [PROCES-RM014](#) contains display elements

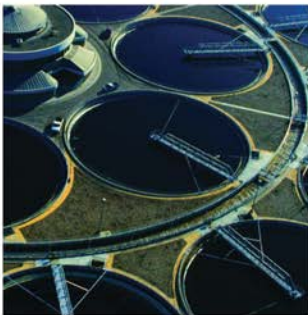

Important User Information

Read this document and the documents listed in the additional resources section about installation, configuration, and operation of this equipment before you install, configure, operate, or maintain this product. Users are required to familiarize themselves with installation and wiring instructions in addition to requirements of all applicable codes, laws, and standards.

Activities including installation, adjustments, putting into service, use, assembly, disassembly, and maintenance are required to be carried out by suitably trained personnel in accordance with applicable code of practice.

If this equipment is used in a manner not specified by the manufacturer, the protection provided by the equipment may be impaired.

In no event will Rockwell Automation, Inc. be responsible or liable for indirect or consequential damages resulting from the use or application of this equipment.

The examples and diagrams in this manual are included solely for illustrative purposes. Because of the many variables and requirements associated with any particular installation, Rockwell Automation, Inc. cannot assume responsibility or liability for actual use based on the examples and diagrams.

No patent liability is assumed by Rockwell Automation, Inc. with respect to use of information, circuits, equipment, or software described in this manual.

Reproduction of the contents of this manual, in whole or in part, without written permission of Rockwell Automation, Inc., is prohibited.

Throughout this manual, when necessary, we use notes to make you aware of safety considerations.



WARNING: Identifies information about practices or circumstances that can cause an explosion in a hazardous environment, which may lead to personal injury or death, property damage, or economic loss.



ATTENTION: Identifies information about practices or circumstances that can lead to personal injury or death, property damage, or economic loss. Attentions help you identify a hazard, avoid a hazard, and recognize the consequence.

IMPORTANT

Identifies information that is critical for successful application and understanding of the product.

Labels may also be on or inside the equipment to provide specific precautions.



SHOCK HAZARD: Labels may be on or inside the equipment, for example, a drive or motor, to alert people that dangerous voltage may be present.



BURN HAZARD: Labels may be on or inside the equipment, for example, a drive or motor, to alert people that surfaces may reach dangerous temperatures.



ARC FLASH HAZARD: Labels may be on or inside the equipment, for example, a motor control center, to alert people to potential Arc Flash. Arc Flash will cause severe injury or death. Wear proper Personal Protective Equipment (PPE). Follow ALL Regulatory requirements for safe work practices and for Personal Protective Equipment (PPE).

Preface	Software Compatibility and Content Revisions	5
	Additional Resources	5
Analog Fanout (P_Fanout)	Guidelines	8
	Functional Description	8
	Required Files	10
	Controller File	10
	Visualization Files	10
	Controller Code	12
	Analog Fanout Input Structure	12
	Analog Fanout Output Structure	18
	Analog Fanout Local Configuration Tags	21
	Operations	22
	Modes	22
	Alarms	22
	Simulation	22
	Execution	23
	Programming Example	23
	Display Elements	25
	Status/Quality Indicators	26
	Mode Indicators	27
	Using Display Elements	28
	Faceplate	30
	Operator Tab	31
	Maintenance Tab	34
	Engineering Tab	36
	Analog Fanout Faceplate Help	41

Notes:

Software Compatibility and Content Revisions

Table 1 - Summary of Changes

Topic	Page
P_Fanout Local Configuration Tags - Navigation Tags	21

For the latest compatible software information and to download the Rockwell Automation® Library of Process Objects, see the Product Compatibility and Download Center at <http://www.rockwellautomation.com/rockwellautomation/support/pcdc.page>.

For general library considerations, see Rockwell Automation Library of Process Objects, publication [PROCES-RM002](#).

Additional Resources

These documents contain additional information concerning related products from Rockwell Automation.

Resource	Description
PlantPAx® Distributed Control System Selection Guide, publication PROCES-SG001	Provides information to assist with equipment procurement for your PlantPAx system.
PlantPAx Distributed Control System Reference Manual, publication PROCES-RM001	Provides characterized recommendations for implementing your PlantPAx system.
Rockwell Automation Library of Process Objects, publication PROCES-RM002	Provides general considerations for the PlantPAx system library of process objects.
FactoryTalk® View Machine Edition User Manual, publication VIEWME-UM004	Provides details on how to use this software package for creating an automation application.
FactoryTalk View Site Edition User Manual, publication VIEWSE-UM006	Provides details on how to use this software package for developing and running human-machine interface (HMI) applications that can involve multiple users and servers, distributed over a network.
Logix5000™ Controllers Add-On Instructions Programming Manual, publication 1756-PM010	Provides information for designing, configuring, and programming Add-On Instructions.
Rockwell Automation Library of Process Objects: Common Mode Block (P_Mode) Reference Manual, publication SYSLIB-RM005	Explains how to select the Mode (owner) of an instruction or control strategy. The Mode instruction is usually embedded within other instructions to extend their functionality. It is possible to use a standalone Mode instruction to enhance a program where modes are wanted.

Notes:

Analog Fanout (P_Fanout)

The Analog Fanout (P_Fanout) Add-On Instruction fans one 'primary' analog output signal out to multiple 'secondary' users or devices. Each secondary output has configurable gain, offset, and clamping limits. The global objects and following faceplate are examples of the graphical interface tools for the Add-On Instruction.

Faceplate

Add-On Instruction

P_Fanout Analog Fanout	
<input type="checkbox"/> Inp_CV	<input type="checkbox"/> Out_CV1
<input type="checkbox"/> Inp_CV1InitVal	<input type="checkbox"/> Out_CV2
<input type="checkbox"/> Inp_CV2InitVal	<input type="checkbox"/> Out_CV3
<input type="checkbox"/> Inp_CV3InitVal	<input type="checkbox"/> Out_CV4
<input type="checkbox"/> Inp_CV4InitVal	<input type="checkbox"/> Out_CV5
<input type="checkbox"/> Inp_CV5InitVal	<input type="checkbox"/> Out_CV6
<input type="checkbox"/> Inp_CV6InitVal	<input type="checkbox"/> Out_CV7
<input type="checkbox"/> Inp_CV7InitVal	<input type="checkbox"/> Out_CV8
<input type="checkbox"/> Inp_CV8InitVal	<input type="checkbox"/> Out_CVInitVal
<input type="checkbox"/> Inp_CV1InitReq	<input type="checkbox"/> Out_CVInitReq
<input type="checkbox"/> Inp_CV2InitReq	<input type="checkbox"/> Val_InpCV
<input type="checkbox"/> Inp_CV3InitReq	<input type="checkbox"/> Val_CV
<input type="checkbox"/> Inp_CV4InitReq	<input type="checkbox"/> Sts_Err
<input type="checkbox"/> Inp_CV5InitReq	<input type="checkbox"/> Sts_Maint
<input type="checkbox"/> Inp_CV6InitReq	<input type="checkbox"/> Sts_Prog
<input type="checkbox"/> Inp_CV7InitReq	<input type="checkbox"/> Sts_Oper
<input type="checkbox"/> Inp_CV8InitReq	

Global Objects

Guidelines

Use this instruction in these situations:

- You want to fan the output of a PID loop, or a P_AOut (Analog Output) Add-On Instruction used as a manual loading station, to multiple valves, drives, or other devices.
- You have 2...8 devices driven by the loop or output.
- You have valves, drives, or other output devices that react over different ranges of the PID or P_AOut output, such as a 'Split-Range' control strategy.
- You want to initialize the primary output signal when all secondaries are requesting initialization.

Do **not** use this instruction in these situations:

- You have only one output device. Use the P_AOut (Analog Output) Add-On Instruction or other output instruction instead. The P_Fanout capabilities are targeted to control strategies where there is a need to have one loop or station drive multiple devices.
- You have multiple PID loops and one output device that uses the highest or lowest of the PID loop outputs (high-select or low-select strategy). Use the ESEL built-in instruction, the P_HiLoSel Add-On Instruction, or other high-select/low-select logic.

Functional Description

The Analog Fanout instruction provides the following capabilities:

- Receives an input CV (controlled variable) from a primary PID loop or analog output.
- Applies rate-of-change limiting to the input signal.
- Calculates outputs for up to eight secondary devices. Each secondary has its own ratio (slope) and offset (intercept) from the rate-limited primary input. The ratios and offsets can come from the Operator or Program, based on mode, or be restricted only to pre-configured values.
- Applies minimum and maximum clamping limits to each output (secondary) CV.
- Provides for initialization of each of its secondary CV outputs based on a request bit and a requested value from the secondary. When a particular output CV comes out of initialization, it is ramped from the initialization value to its calculated value by using a configured 'Takeup' Rate.

- Provides for initialization of the primary when all secondaries have requested initialization. The initialization value sent to the primary can be a fixed (configured) value or a calculated value based on the CV1 (Output 1) requested initialization value, accounting for the CV1 gain and offset. Thus CV1 is the 'priority' output.

TIP

If you are using the P_Fanout Add-On Instruction in a split-range strategy (its default configuration), use CV1 for the 'safe' part of the range (for example, a chilled water valve) and CV2 for the 'unsafe' part of the range (for example, a steam valve). If both CV1 and CV2 request initialization, the loop (primary) is initialized based on the requested value from CV1 and set to a value in the cooling range.

For example, a P_Fanout Add-On Instruction is configured to use input range 0...50% as 100...0% open on the cooling valve on CV1, and input range 50...100% as 0...100% on the heating valve on CV2. If both valves request initialization, the P_Fanout Add-On Instruction uses the CV1 initialization value and requests the primary to initialize in the 0...50% range, the cooling side.

If the heating valve is used as CV1, the initialization is always in the heating range of the primary CV. In many split-range applications, it is a requirement to initialize or fail in the cooling range (for example, 0...50% output, for 100...0% cooling and always 0% heating).

The default configuration of the P_Fanout instruction provides this cooling (CV1) and heating (CV2) setup, with CV3...CV8 not used.

Required Files

Add-On Instructions are reusable code objects that contain encapsulated logic that can streamline implementing your system. This lets you create your own instruction set for programming logic as a supplement to the instruction set provided natively in the ControlLogix® firmware. An Add-On Instruction is defined once in each controller project, and can be instantiated multiple times in your application code as needed.

Controller File

The P_Fanout_3_5-00_AOIL5X Add-On Instruction must be imported into the controller project to be used in the controller configuration. The service release number (boldfaced) can change as service revisions are created.

Visualization Files

This Add-On Instruction has associated visualization files that provide a common user interface. These files can be downloaded from the Product Compatibility and Download Center at <http://www.rockwellautomation.com/rockwellautomation/support/pcdc.page>.

IMPORTANT	The visualization file dependencies require Process Library content imports to occur in a specific order as reflected in the following tables: <ul style="list-style-type: none"> • Images • Global Objects • Standard Displays • HMI Tags • Macros
------------------	--

Images are external graphic files that can be used in displays. They must be imported for FactoryTalk View to make use of them.

When PNG files are imported, they are renamed by FactoryTalk View with a .bmp file extension, but retain a .png format.

Table 2 - Visualization Files: Images (.png)

FactoryTalk View SE Software	FactoryTalk View ME Software	Description
All .png files in the images folder	All .png files in the images folder	These are the common icons used in the global objects and standard displays for all Process Objects.

The Global Object files (.ggfx file type) in the following table are Process Library display elements that are created once and referenced multiple times on multiple displays in an application. When changes are made to a Global Object, all instances in the application are automatically updated.

Table 3 - Visualization Files: Global Objects (.ggfx)

FactoryTalk View SE Software	FactoryTalk View ME Software	Description
(RA-BAS) Common Faceplate Objects	(RA-BAS-ME) Common Faceplate Objects	Global objects used on process object faceplates.

Table 3 - Visualization Files: Global Objects (.ggfx)

FactoryTalk View SE Software	FactoryTalk View ME Software	Description
(RA-BAS) Process Faceplate Analog Objects	(RA-BAS-ME) Process Faceplate Analog Objects	Analog global objects used on process object faceplates.
(RA-BAS) Process Graphics Library	(RA-BAS-ME) Process Graphics Library	Process global object device symbols used to build process graphics
(RA-BAS) Process Help Objects	(RA-BAS-ME) Process Help Objects	Global objects used for all process objects help displays.
(RA-BAS) Process Mode Objects	(RA-BAS-ME) Process Mode Objects	Global objects used for managing modes on process object faceplates.

The Standard Display files (.gfx file type) in the following table are the Process Library displays that you see at runtime.

Table 4 - Visualization Files: Standard Displays (.gfx)

FactoryTalk View SE Software	FactoryTalk View ME Software	Description
(RA-BAS) Common-AnalogEdit	N/A	Faceplate used for analog input data entry. The FactoryTalk View ME faceplates use the native analog input data entry so no file is required.
(RA-BAS) P_Fanout5-Faceplate	(RA-BAS-ME) P_Fanout5-Faceplate	The faceplate display that is used for the object when outputs 6, 7, or 8 are not used.
(RA-BAS) P_Fanout-Faceplate	(RA-BAS-ME) P_Fanout-Faceplate	The faceplate display that is used for the object when outputs 6, 7, or 8 are used.
(RA-BAS) P_Mode-Config	(RA-BAS-ME) P_Mode-Config	The Configuration Display used to configure the P_Mode object.
(RA-BAS) P_Mode-Help	(RA-BAS-ME) P_Mode-Help	Mode Help information that is accessed from the Help faceplate.
(RA-BAS) Process Analog Family-Help	(RA-BAS-ME) Process Analog Family-Help	The Help display for Analog objects

HMI Tags are created in a FactoryTalk View ME application to support tab switching on Process Library faceplates. The HMI tags may be imported via the comma-separated values file (.csv file type) in the following table.

Table 5 - Visualization Files: HMI Tags (.csv)

FactoryTalk View SE Software	FactoryTalk View ME Software	Description
N/A	FTVME_PlantPaxLib_Tags_3_5_XX.csv where XX = the service release number.	These tags must be imported into the FactoryTalk View ME project to support switching tabs on any Process Object faceplate.

In a FactoryTalk View SE application, a macro is a series of commands stored in a text file. In FactoryTalk View ME application, a macro is a list of tag assignments stored in a text file. The following table lists the Macros (.mcr file type) used by the Process Library.

Table 6 - Visualization Files: Macros (.mcr file)

FactoryTalk View SE Software	FactoryTalk View ME Software	Description
NavToObject	N/A	This macro must be imported into the FactoryTalk View SE project to support faceplate-to-faceplate navigation by name.

Controller Code

This section describes the parameter references for this Add-On Instruction.

Analog Fanout Input Structure

Input parameters include the following:

- Input data elements (Inp_) are typically used to connect field inputs from I/O modules or signals from other objects.
- Configuration data elements (Cfg_) are used to set configurable capabilities and features of the instruction.
- Command data elements (PCmd_, OCmd_) are used by program logic, operators, and maintenance personnel to request instruction actions.
- Setting data elements (PSet_, OSet_) are used by program logic, operators, and maintenance personnel to establish runtime setpoints, thresholds, and so forth.

Table 7 - P_Fanout Input Parameters

Input Parameter	Data Type	Alias For	Default	Description
EnableIn	BOOL		1	<p>Ladder Diagram: If the rung-in condition is true, the instruction's Logic routine executes. If the rung-in condition is false, the instruction's EnableInFalse routine executes.</p> <p>Function Block Diagram: If true, or not connected, the instruction's Logic routine executes. If the parameter is exposed as a pin and wired, and the pin is false, the instruction's EnableInFalse routine executes.</p> <p>Structured Text: No effect. The instruction's Logic routine executes.</p>
Inp_CV	REAL		0.0	Input CV from Upstream block's output (engineering units).
Inp_CV1InitVal	REAL		0.0	Initialization value from downstream block 1...8 (in the associated CV engineering units).
Inp_CV2InitVal				
Inp_CV3InitVal				
Inp_CV4InitVal				
Inp_CV5InitVal				
Inp_CV6InitVal				
Inp_CV7InitVal				
Inp_CV8InitVal				
Inp_CV1InitReq	BOOL		0	<p>Initialization request from downstream block 1...8. When these parameters are set to 1, the corresponding CV output is set to the value of the corresponding initialization input. For example, if Inp_CV1InitReq is 1, Out_CV1 is set to Inp_CV1InitVal.</p> <p>When all configured CVs have their initialization request set, Out_CVInitReq is set to 1 and Out_CVInitVal is set to a value based on Inp_CV1InitVal and the ratio and offset for CV1.</p>
Inp_CV2InitReq				
Inp_CV3InitReq				
Inp_CV4InitReq				
Inp_CV5InitReq				
Inp_CV6InitReq				
Inp_CV7InitReq				
Inp_CV8InitReq				

Table 7 - P_Fanout Input Parameters

Input Parameter	Data Type	Alias For	Default	Description
Cfg_CV1RatioSrc	BOOL		0	1 = Use PSet/OSet Ratio. 0 = Use Cfg Ratio. Selects whether the ratio used to calculate outputs is determined by operator or program setting (for example, PSet_CV1Ratio or OSet_CV1Ratio) or by configuration (for example, Cfg_CV1Ratio).
Cfg_CV2RatioSrc				
Cfg_CV3RatioSrc				
Cfg_CV4RatioSrc				
Cfg_CV5RatioSrc				
Cfg_CV6RatioSrc				
Cfg_CV7RatioSrc				
Cfg_CV8RatioSrc				
Cfg_CV10OffsetSrc	BOOL		0	1 = Use PSet/OSet Offset. 0 = Use Cfg Offset. Selects whether the offset used to calculate outputs is determined by operator or program setting (for example, PSet_CV10Offset or OSet_CV10Offset) or by configuration (for example, Cfg_CV10Offset).
Cfg_CV20OffsetSrc				
Cfg_CV30OffsetSrc				
Cfg_CV40OffsetSrc				
Cfg_CV50OffsetSrc				
Cfg_CV60OffsetSrc				
Cfg_CV70OffsetSrc				
Cfg_CV80OffsetSrc				
Cfg_HasCV2	BOOL		1	1 = Output CV2 ... CV8 are connected and are to be used.
Cfg_HasCV3			0	
Cfg_HasCV4				
Cfg_HasCV5				
Cfg_HasCV6				
Cfg_HasCV7				
Cfg_HasCV8				
Cfg_FixedInitVal	REAL		0.0	Fixed Initialization value (in Inp_CV engineering units), used if Cfg_UseFixedInit = 1.
Cfg_UseFixedInit	BOOL		0	1 = Use Cfg_FixedInitVal to initialize primary. 0 = Use Inp_CV1InitVal.
Cfg_ShedHold	BOOL		0	1 = Hold Output on Inf/NaN Input. 0 = Copy Inf/NaN through.
Cfg_SetTrack	BOOL		1	This parameter is used to set up bumpless behavior of setting parameters when switching modes. When this parameter is 1 and in Program mode; the operator settings track the program settings. In Operator mode the program settings track the operator settings. Simulation inputs match the output values (transitions are bumpless). When this parameter is 0, the operator settings and program settings are not modified by this instruction. In this case, when the mode is changed, the effective value of the setting can change depending on the program-set and operator-set values.
Cfg_HasCVNav	BOOL		0	1 = Tells HMI to enable navigation to a connected input CV object.

Table 7 - P_Fanout Input Parameters

Input Parameter	Data Type	Alias For	Default	Description
Cfg_HasNav	INT		0	Set bits indicate which Navigation buttons are enabled: Bit .0 = CV1 Output Navigation Bit .1 = CV2 Output Navigation Bit .2 = CV3 Output Navigation Bit .3 = CV4 Output Navigation Bit .4 = CV5 Output Navigation Bit .5 = CV6 Output Navigation Bit .6 = CV7 Output Navigation Bit .7 = CV8 Output Navigation
Cfg_PCmDClear	BOOL		0	When this parameter is 1, program commands are cleared once they are acted upon. When set to 0, program commands remain set until cleared by the application program logic. IMPORTANT: Clearing this parameter online can cause unintended program command execution.
Cfg_ProgDefault	BOOL	Mode.Cfg_ProgDefault	0	This parameter defines the default mode. When this parameter is 1, the mode defaults to Program if no mode is being requested. When this parameter is 0, the mode defaults to Operator if no mode is being requested. IMPORTANT: Changing this parameter online can cause unintended mode changes.
Cfg_CVEUMin	REAL		0.0	These parameters must be set to the range of the signal connected to Inp_CV.
Cfg_CVEUMax			100.0	
Cfg_CVMin	REAL		0.0	Input CV minimum (Lo Clamp) or CV maximum (Hi Clamp) (in engineering units).
Cfg_CVMax			100.0	
Cfg_MaxCVRoC	REAL		10.0	Maximum allowed CV rate of change setting (in engineering units/second).
Cfg_CV1Ratio	REAL		-2.0	Configuration for CV1...CV8 ratios. These parameters are used to calculate the corresponding output when the ratio source for the output is configuration. For example, Cfg_CV1Ratio is used to calculate Out_CV1 when Cfg_CV1RatioSrc = 0. The selected ratio is stored in output parameters and the instruction uses the output parameters for the calculations (for example, Out_CV1 = Inp_CV * Val_CV1Ratio + Val_CV1Offset).
Cfg_CV2Ratio			2.0	
Cfg_CV3Ratio			1.0	
Cfg_CV4Ratio				
Cfg_CV5Ratio				
Cfg_CV6Ratio				
Cfg_CV7Ratio				
Cfg_CV8Ratio				
Cfg_CV1Offset	REAL		100.0	Configuration for CV1...CV8 offsets. These parameters are used to calculate the corresponding output when the offset source for the output is configuration. For example, Cfg_CV1Offset is used to calculate Out_CV1 when Cfg_CV1OffsetSrc = 0. The selected offset is stored in output parameters and the instruction uses the output parameters for the calculations (for example, Out_CV1 = Inp_CV * Val_CV1Ratio + Val_CV1Offset).
Cfg_CV2Offset			-100.0	
Cfg_CV3Offset			0.0	
Cfg_CV4Offset				
Cfg_CV5Offset				
Cfg_CV6Offset				
Cfg_CV7Offset				
Cfg_CV8Offset				

Table 7 - P_Fanout Input Parameters

Input Parameter	Data Type	Alias For	Default	Description
Cfg_CV1Min	REAL		0.0	Output CV1...CV8 minimum in engineering units (for clamping).
Cfg_CV2Min				
Cfg_CV3Min				
Cfg_CV4Min				
Cfg_CV5Min				
Cfg_CV6Min				
Cfg_CV7Min				
Cfg_CV8Min				
Cfg_CV1Max	REAL		100.0	Output CV1...CV8 maximum in engineering units (for clamping).
Cfg_CV2Max				
Cfg_CV3Max				
Cfg_CV4Max				
Cfg_CV5Max				
Cfg_CV6Max				
Cfg_CV7Max				
Cfg_CV8Max				
Cfg_CV1TakeupRate	REAL		1.0	Rate (in engineering units/second) which CV1...CV8 bias is taken up after the corresponding Inp_CVInitReq clears to 0.
Cfg_CV2TakeupRate				
Cfg_CV3TakeupRate				
Cfg_CV4TakeupRate				
Cfg_CV5TakeupRate				
Cfg_CV6TakeupRate				
Cfg_CV7TakeupRate				
Cfg_CV8TakeupRate				
PSet_CVRoCLim	REAL		0.0	Program setting for Input CV rate of change limit (increase or decrease) (in engineering units/second).
PSet_CV1Ratio	REAL		-2.0	Program setting for CV1...CV8 ratios. These parameters are used to calculate the corresponding output when the mode is Program and the ratio source for the output is set to use the setting parameters. For example, PSet_CV1Ratio is used to calculate Out_CV1 when Cfg_CV1RatioSrc = 1 and the mode is Program. The selected ratio is stored in output parameters and the instruction uses the output parameters for the calculations (for example, Out_CV1 = Inp_CV * Val_CV1Ratio + Val_CV1offset).
PSet_CV2Ratio			2.0	
PSet_CV3Ratio			1.0	
PSet_CV4Ratio				
PSet_CV5Ratio				
PSet_CV6Ratio				
PSet_CV7Ratio				
PSet_CV8Ratio				

Table 7 - P_Fanout Input Parameters

Input Parameter	Data Type	Alias For	Default	Description
PSet_CV10Offset	REAL		100.0	<p>Program setting for CV1 . . . CV8 offsets.</p> <p>These parameters are used to calculate the corresponding output when the mode is Program and the offset source for the output is set to use the setting parameters. For example, PSet_CV10Offset is used to calculate Out_CV1 when Cfg_CV10OffsetSrc = 1 and the mode is Program.</p> <p>The selected offset is stored in output parameters and the instruction uses the output parameters for the calculations (for example, $Out_CV1 = Inp_CV * Val_CV1Ratio + Val_CV10Offset$).</p>
PSet_CV20Offset			-100.0	
PSet_CV30Offset			0.0	
PSet_CV40Offset				
PSet_CV50Offset				
PSet_CV60Offset				
PSet_CV70Offset				
PSet_CV80Offset				
PSet_Owner	DINT		0	Program owner request ID (non-zero) or release (zero).
OSet_CVRoCLim	REAL		0.0	Operator setting for Input CV rate of change limit (increasing or decreasing) (in engineering units/second).
OSet_CV1Ratio	REAL		-2.0	<p>Operator setting for CV1 . . . CV8 ratios.</p> <p>These parameters are used to calculate the corresponding output when the mode is Operator and the ratio source for the output is set to use the setting parameters. For example, OSet_CV1Ratio is used to calculate Out_CV1 when Cfg_CV1RatioSrc = 1 and the mode is Operator.</p> <p>The selected ratio is stored in output parameters and the instruction uses the output parameters for the calculations (for example, $Out_CV1 = Inp_CV * Val_CV1Ratio + Val_CV10Offset$).</p>
OSet_CV2Ratio			2.0	
OSet_CV3Ratio			1.0	
OSet_CV4Ratio				
OSet_CV5Ratio				
OSet_CV6Ratio				
OSet_CV7Ratio				
OSet_CV8Ratio				
OSet_CV10Offset	REAL		100.0	<p>Operator setting for CV1 . . . CV8 offsets.</p> <p>These parameters are used to calculate the corresponding output when the mode is Operator and the offset source for the output is set to use the setting parameters. For example, OSet_CV10Offset is used to calculate Out_CV1 when Cfg_CV10OffsetSrc = 1 and the mode is Operator.</p> <p>The selected offset is stored in output parameters and the instruction uses the output parameters for the calculations (for example, $Out_CV1 = Inp_CV * Val_CV1Ratio + Val_CV10Offset$).</p>
OSet_CV20Offset			-100.0	
OSet_CV30Offset			0.0	
OSet_CV40Offset				
OSet_CV50Offset				
OSet_CV60Offset				
OSet_CV70Offset				
OSet_CV80Offset				
PCmd_Acq	BOOL	Mode.PCmd_Acq	0	<p>When Cfg_PCmdClear is 1:</p> <ul style="list-style-type: none"> Set PCmd_Acq to 1 to Acquire Set PCmd_Rel to 1 to Release These parameters reset automatically <p>When Cfg_PCmdClear is 0:</p> <ul style="list-style-type: none"> Set PCmd_Acq to 1 to Acquire Set PCmd_Acq to 0 to Release PCmd_Rel is not used These parameters do not reset automatically
PCmd_Rel		Mode.PCmd_Rel		
PCmd_Lock	BOOL	Mode.PCmd_Lock	0	<p>When Cfg_PCmdClear is 1:</p> <ul style="list-style-type: none"> Set PCmd_Lock to 1 to Lock Set PCmd_Unlock to 1 to Unlock These parameters reset automatically <p>When Cfg_PCmdClear is 0:</p> <ul style="list-style-type: none"> Set PCmd_Lock to 1 to Lock Set PCmd_Lock to 0 to Unlock PCmd_Unlock is not used These parameters do not reset automatically
PCmd_Unlock		Mode.PCmd_Unlock		

Table 7 - P_Fanout Input Parameters

Input Parameter	Data Type	Alias For	Default	Description
MCmd_Acq	BOOL	Mode.MCmd_Acq	0	Maintenance command to acquire ownership (Operator/Program/Override to Maintenance).
MCmd_Rel	BOOL	Mode.MCmd_Rel	0	Maintenance command to release ownership (Maintenance to Operator/Program/Override).
OCmd_AcqLock	BOOL	Mode.OCmd_AcqLock	0	Operator command to acquire (Program to Operator)/Lock Ownership.
OCmd_Unlock	BOOL	Mode.OCmd_UnlockRel	0	Operator command to unlock/release (Operator to Program) Ownership.

Analog Fanout Output Structure

Output parameters include the following:

- Output data elements (Out_) are the primary outputs of the instruction, typically used by hardware output modules; however, they can be used by other application logic.
- Value data elements (Val_) are numeric outputs of the instruction for use by the HMI. Values can also be used by other application logic or software packages.
- Status data elements (Sts_) are bit outputs of the instruction for use by the HMI. Status bits can also be used by other application logic.
- Error data elements (Err_) are outputs of the instruction that indicate a particular configuration error. If any Err_bit is set then the Sts_Err configuration error summary status is set and the Invalid Configuration indicator is displayed on the HMI.
- Ready data elements (Rdy_) are bit outputs of the instruction used by the HMI to enable or disable Command buttons and Setting entry fields.

Table 8 - P_Fanout Output Parameters

Output Parameter	Data Type	Alias For	Description
EnableOut	BOOL		Enable Output: The EnableOut signal is not manipulated by this instruction. Its output state always reflects EnableIn Input state.
Out_CV1	REAL		Calculated outputs in engineering units. For example, $Out_CV1 = Inp_CV * Val_CV1Ratio + Val_CV1Offset$.
Out_CV2			
Out_CV3			
Out_CV4			
Out_CV5			
Out_CV6			
Out_CV7			
Out_CV8			
Out_CVInitVal	REAL		Initialization value to upstream block (Inp_CV engineering units).
Out_CVInitReq	BOOL		Initialization request to upstream block (1 = Initialize).
Val_CVEUMin	REAL		Minimum of scaled range = Minimum (Cfg_CVEUMin, Cfg_CVEUMax).
Val_CVEUMax	REAL		Maximum of scaled range = Maximum (Cfg_CVEUMin, Cfg_CVEUMax).
Val_InpCV	REAL		Value of Inp_CV (not clamped or ramped) (engineering units).
Val_CV	REAL		Value of CV after clamping and ramping (engineering units).
Val_CVRoCLim	REAL		Accepted setting for Input CV rate of change limit (increasing or decreasing) (Inp engineering units/second).

Table 8 - P_Fanout Output Parameters

Output Parameter	Data Type	Alias For	Description
Val_CV1Ratio	REAL		Value of selected CV1 . . . CV8 ratio settings.
Val_CV2Ratio			
Val_CV3Ratio			
Val_CV4Ratio			
Val_CV5Ratio			
Val_CV6Ratio			
Val_CV7Ratio			
Val_CV8Ratio			
Val_CV10Offset	REAL		Value of selected CV1 . . . CV8 offset settings.
Val_CV20Offset			
Val_CV30Offset			
Val_CV40Offset			
Val_CV50Offset			
Val_CV60Offset			
Val_CV70Offset			
Val_CV80Offset			
Val_MinCVIn1	REAL		Input CV at minimum of CV1 . . . CV8 outputs. These are used to display the configuration in graph form on the faceplate.
Val_MinCVIn2			
Val_MinCVIn3			
Val_MinCVIn4			
Val_MinCVIn5			
Val_MinCVIn6			
Val_MinCVIn7			
Val_MinCVIn8			
Val_MaxCVIn1	REAL		Input CV at maximum of CV1 . . . CV8 outputs. These are used to display the configuration in graph form on the faceplate.
Val_MaxCVIn2			
Val_MaxCVIn3			
Val_MaxCVIn4			
Val_MaxCVIn5			
Val_MaxCVIn6			
Val_MaxCVIn7			
Val_MaxCVIn8			
Val_Mode	SINT	Mode.Val	The current mode is shown with status bits and also as an enumeration 'Val_Mode' as follows: 0 = No mode 2 = Maintenance 4 = Program (locked) 5 = Operator (locked) 6 = Program (unlocked, Operator is default) 7 = Operator (unlocked, Program is default) 8 = Program (unlocked, Program is default) 9 = Operator (unlocked, Operator is default)
Val_Owner	DINT		Current object owner ID (0 = not owned).

Table 8 - P_Fanout Output Parameters

Output Parameter	Data Type	Alias For	Description
Sts_CVInfNaN	BOOL		1 = Inp_CV is infinite or Not A Number (1.\$, 1.#NaN).
Sts_CVLimited	BOOL		1 = Val_CV clamped at configured maximum/minimum.
Sts_CV1InitInfNaN	BOOL		1 = Inp_CV1...CV8 InitVal is infinite or Not a Number.
Sts_CV2InitInfNaN			
Sts_CV3InitInfNaN			
Sts_CV4InitInfNaN			
Sts_CV5InitInfNaN			
Sts_CV6InitInfNaN			
Sts_CV7InitInfNaN			
Sts_CV8InitInfNaN			
Sts_CV1Limited	BOOL		1 = Output CV1...CV8 clamped at configured maximum/minimum.
Sts_CV2Limited			
Sts_CV3Limited			
Sts_CV4Limited			
Sts_CV5Limited			
Sts_CV6Limited			
Sts_CV7Limited			
Sts_CV8Limited			
Sts_Err	BOOL		1 = Error in configuration: See detail bits for reason.
Err_Limit	BOOL		1 = Error in configuration: CV Clamp Limits crossed (maximum < minimum).
Err_EU	BOOL		1 = Error in configuration: CV Scale engineering units minimum = maximum.
Err_CV1Limit	BOOL		1 = Error in configuration: CV1...CV8 clamp limits crossed (maximum < minimum).
Err_CV2Limit			
Err_CV3Limit			
Err_CV4Limit			
Err_CV5Limit			
Err_CV6Limit			
Err_CV7Limit			
Err_CV8Limit			
Sts_Maint	BOOL	Mode.Sts_Maint	1 = Mode is Maintenance (supersedes Program and Operator).
Sts_Prog	BOOL	Mode.Sts_Prog	1 = Mode is Program (auto).
Sts_Oper	BOOL	Mode.Sts_Oper	1 = Mode is Operator (manual).
Sts_ProgOperLock	BOOL	Mode.Sts_ProgOperLock	1 = Program or Operator has requested mode lock.
Sts_NoMode	BOOL	Mode.Sts_NoMode	1 = No mode (disabled because EnableIn is false).
Sts_MAcqRcvd	BOOL	Mode.Sts_MAcqRcvd	1 = Maintenance Acquire command received this scan.
Rdy_OSet	BOOL		1 = Ready to receive OSets (enables data entry fields).
P_Fanout	BOOL		Unique parameter name for auto-discovery.

Analog Fanout Local Configuration Tags

Configuration parameters that are array, string, or structure data types cannot be configured as parameters for Add-On Instructions. Configuration parameters of these types appear as local tags to the Add-On Instruction. Local tags can be configured through the HMI faceplates or in Studio 5000 Logix Designer® application by opening the Instruction Logic of the Add-On Instruction instance and then opening the Data Monitor on a local tag. These parameters cannot be modified by using controller logic or Logix Designer application export/import functionality.

Table 9 - P_Fanout Local Configuration Tags

Tag Name	Data Type	Default	Description
Cfg_CV1_EU	STRING_8	'%	Output 1 . . . 8 engineering units for display on HMI.
Cfg_CV2_EU			
Cfg_CV3_EU			
Cfg_CV4_EU			
Cfg_CV5_EU			
Cfg_CV6_EU			
Cfg_CV7_EU			
Cfg_CV8_EU			
Cfg_CV1_Label	STRING_20	'Output 1'	Output 1 . . . 8 labels for display on HMI.
Cfg_CV2_Label		'Output 2'	
Cfg_CV3_Label		'Output 3'	
Cfg_CV4_Label		'Output 4'	
Cfg_CV5_Label		'Output 5'	
Cfg_CV6_Label		'Output 6'	
Cfg_CV7_Label		'Output 7'	
Cfg_CV8_Label		'Output 8'	
Cfg_CVNavTag	STRING_NavTag	''	Tag name for destination of input CV Navigation button. IMPORTANT: This tag does not work in FactoryTalk ME software.
Cfg_CV_EU	STRING_8	'%	Engineering units for display on HMI.
Cfg_Desc	STRING_40	'Analog Fanout'	Description for display on HMI. This string is shown in the title bar of the faceplate.
Cfg_Label	STRING_20	'Analog Fanout'	Label for graphic symbol displayed on HMI. This string appears on the graphic symbol.
Cfg_NavTag	STRING_NavTag[8]	''	Tag names for destinations of Navigation buttons ([0]-[7] = outputs). IMPORTANT: This tag does not work in FactoryTalk ME software.
Cfg_Tag	STRING_20	'P_Fanout'	Tag name for display on HMI. This string is shown in the title bar of the faceplate.

Operations

This section describes the primary operations for Add-On Instructions.

Modes

This instruction uses the following standard modes, which are implemented by using an embedded P_Mode Add-On Instruction.

Table 10 - Modes

Mode	Description
Operator	The Operator owns control of the device. Operator commands (OCmd_) and Operator settings (OSet_) from the HMI are accepted.
Program	Program logic owns control of the device. Program commands (PCmd_) and Program settings (PSet_) are accepted.
Maintenance	Maintenance owns control of the device and supersedes Operator, Program, and Override control. Operator commands and settings from the HMI are accepted. Bypassable interlocks and permissives are bypassed, and device timeout checks are not processed.
No Mode	The device is disabled and has no owner because the EnableIn input is false. The main instruction Logic routine is not being scanned. See Execution section for more information on EnableInFalse processing.

The following standard modes are not used:

- Hand mode
- Override (Ovr) mode

See Rockwell Automation Library of Process Objects: Common Mode Block (P_Mode) Reference Manual, publication [SYSLIB-RM005](#), for more information.

Alarms

The P_Fanout instruction does not provide any alarms. It does provide Status bits that identify if the input CV or any particular output CV is being limited or if any input value (input CV or any of the individual CV initialization values) is Infinite (Inf) or Not a Number (NaN).

Simulation

The P_Fanout Add-On Instruction does not have simulation capability.

Execution

The following table explains the handling of instruction execution conditions.

Condition	Description
EnableIn False (false rung)	The mode is shown as 'NO MODE'. Otherwise, the instruction is kept in its last state.
Powerup (prescan, first scan)	On Prescan, ownership of the instruction is cleared. The CV Rate limiter is set to initialize at the first valid CV received.
Postscan	No SFC Postscan logic is provided.

See the Logix5000 Controllers Add-On Instructions Programming Manual, publication [1756-PM010](#), for more information.

Programming Example

This example uses the P_Fanout instruction to implement a split range PID control strategy to control temperature of a processing vessel. In this example, the heat exchanger to the vessel jacket is fed by either a steam valve to heat or a glycol valve to cool. One PID controller is used to control temperature. It is assumed that the relative process gain between each valve and the temperature is the same.

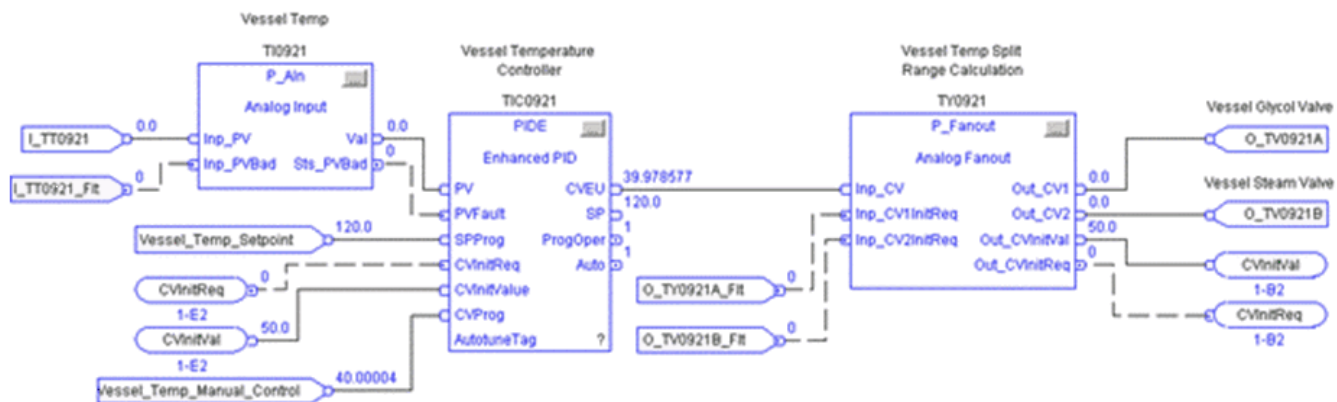

To connect the PIDE instruction to the P_Fanout instruction, the PIDE output (CVEU) is connected to the input (Inp_CV) of P_Fanout. P_Fanout outputs Out_CVInitVal and Out_CVInitReq are connected to PIDE inputs CVInitReq and CVInitVal to be sure of proper initialization of the PIDE loop if there are issues with either valve.

Cfg_HasCV2 is set to 1 to indicate P_Fanout connects to two outputs. Cfg_CV1RatioSrc, Cfg_CV1OffsetSrc, Cfg_CV2RatioSrc, and Cfg_CV2OffsetSrc are all left at 0 to indicate that the scaling used to calculate the valve outputs is configured and not dynamically set by the operator or program.

To handle initialization, Cfg_FixedInitVal is set to 50 so that the PIDE instruction initializes with both valves closed when initialization is requested.

Cfg_UseFixedInit is set to 1 to indicate the fixed initialization value is to be used instead of the feedback from the glycol valve.

To properly scale the two outputs, the scaling configuration values are set as follows:

Cfg_CV1Ratio:	-2.04
Cfg_CV1Offset:	100
Cfg_CV1Min:	0
Cfg_CV1Max:	100

Cfg_CV2Ratio:	2.04
Cfg_CV2Offset:	-103
Cfg_CV2Min:	0
Cfg_CV2Max:	100

These values cause a 50% output on the vessel temperature controller to command both the glycol and the steam valve closed (0%). As the PIDE output approaches 0%, the glycol valve opens (approach 100%). As the PIDE output approaches 100%, the steam valve opens (approach 100%). These settings create a little deadband around 50% where neither valve opens to prevent chattering between glycol and steam to prevent excessive wear on the heat exchanger.

P_Fanout outputs Out_CV1 and Out_CV2 are connected to the outputs to the glycol and steam valves. Valve status information is brought in through inputs Inp_CV1InitReq and Inp_CV2InitReq to be sure that the control loop initializes if there is a problem with a valve. Based on the preceding settings, initialization commands both valves closed.

Lastly, the following local configuration tags are configured to drive the text on the HMI global object and faceplate. In this example, they are set as follows:

Cfg_Tag:	TY0921
Cfg_Label:	Vessel 0900 Split Range
Cfg_Desc:	Vessel Split Range Calculation
Cfg_CV1_Label:	Glycol Valve
Cfg_CV2_Label:	Steam Valve
Cfg_CV1_EU:	%
Cfg_CV2_EU:	%

Display Elements

A display element (global object) is created once and can be referenced multiple times on multiple displays in an application. When changes are made to the original (base) object, the instantiated copies (reference objects) are automatically updated. Use of global objects, in conjunction with tag structures in the ControlLogix system, aid consistency and save engineering time.

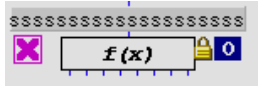
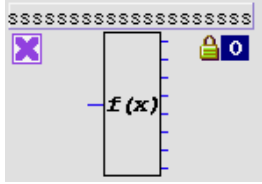
Display Element Name	Display Element	Description
GO_P_Fanout		P_Fanout global object (horizontal layout).
GO_P_Fanout1		P_Fanout global object (vertical layout).

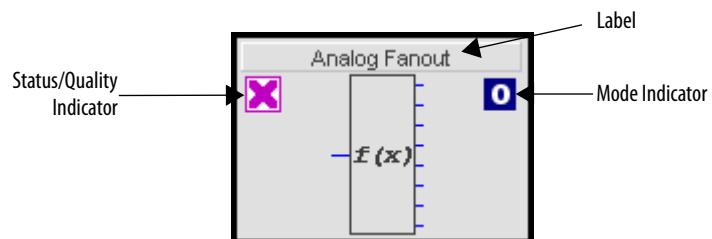

Common attributes of the P_Fanout objects include the following:

- Status/Quality indicator
- Mode indicator
- Label



Status/Quality Indicators

One of these symbols appears on the graphic symbol when the described condition is true.

Graphic Symbol	Description
	Invalid configuration.
	Input Value clamped to minimum/maximum.
	Output value clamped to minimum/maximum.







TIP When the Invalid Configuration Indicator appears, you can find what configuration setting is invalid by following the indicators. Click the graphic symbol to open the faceplate. The Invalid Configuration indicator appears next to the appropriate tab at the top of the faceplate to guide you in finding the configuration error. Once you navigate to the tab, the misconfigured item is flagged with this indicator or appears in a magenta box.

For the Analog Fanout Instruction, the Invalid Configuration Indicator appears under the following conditions:

- Scaled EU Minimum and EU Maximum scaling parameters are set to the same value.
- Input CV Maximum clamping limit is less than its Minimum clamping limit.
- Any Output CV's Maximum clamping limit is less than its Minimum clamping limit.

Mode Indicators

One of these symbols appears to the right of the graphic symbol to indicate the mode of the object instruction.

Graphic Symbol	Description
Transparent	Operator mode (if the default mode is Operator and in Operator mode, the mode indicator is transparent)
	Operator mode (if the default mode is Program)
	Operator mode locked
Transparent	Program mode (if the default mode is Program and in Program mode, the mode indicator is transparent)
	Program mode (if the default mode is Operator)
	Program mode locked
	Maintenance mode
	No mode

TIP The images provided for the Operator and Program default modes are completely transparent; therefore, no mode indicators appear if the device is in its default mode. This behavior can be changed by replacing these mode indicators with images that are not completely transparent.

Using Display Elements

The global objects for P_Fanout can be found in the global object file (RA-BAS) Process Graphics Library.ggfx. Complete the following to use a global object.

1. Copy it from the global object file and paste it in the display file.

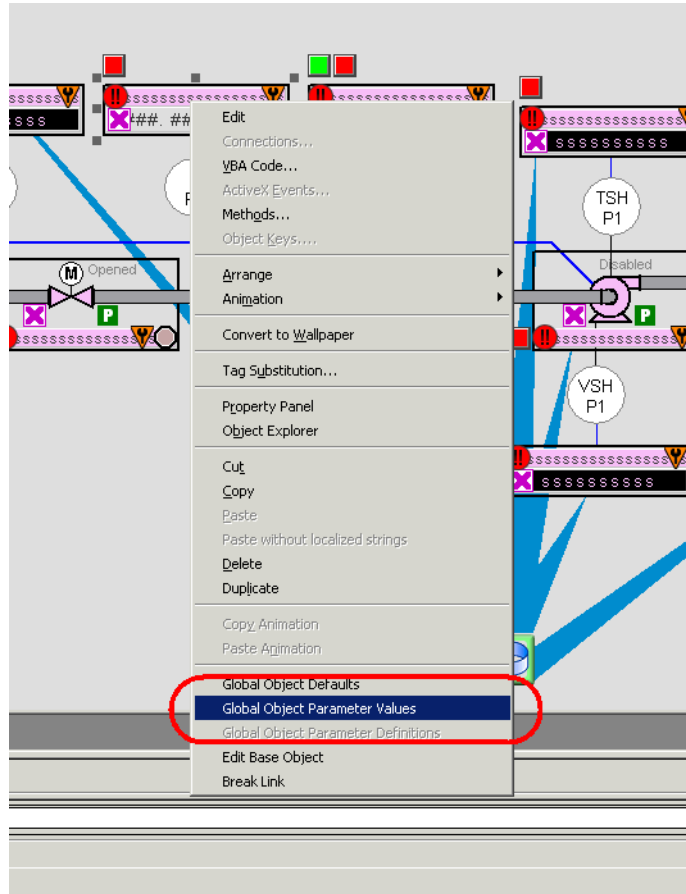

2. In the display, right-click the global object and choose Global Object Parameter Values.

The Global Object Parameter Values dialog box appears.

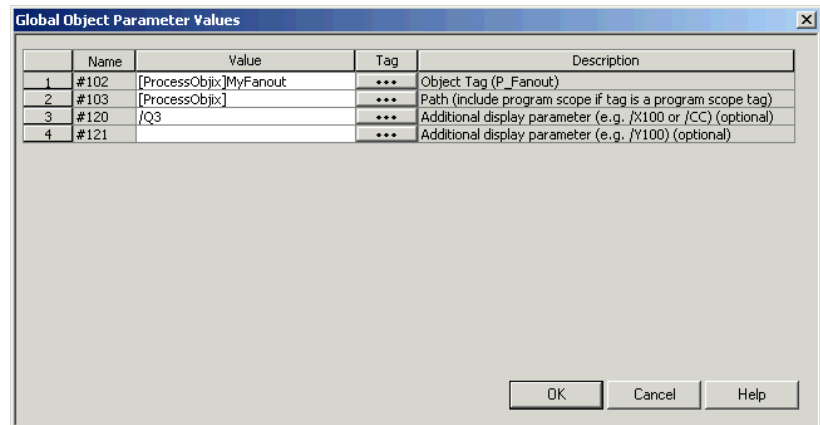

3. Type the tag or value in the Value column as specified in the Description column.

TIP You can click the ellipsis (...) to browse and select a tag.

4. Click OK.

Parameter	Required	Description
#102	Y	Object tag to point to the name of the associated object Add-On Instruction in the controller.
#103	Y	Path used for display navigation features to other objects. Include program scope if tag is a program scope tag.
#120	N	Additional parameter to pass to the display command to open the faceplate. Typically used to define position for the faceplate.
#121	N	Additional parameter to pass to the display command to open the faceplate. if defining X and Y coordinate, separate parameters so that X is defined by #120 and Y is defined by #121. This lets the same parameters be used in subsequent display commands originating from the faceplate.

Faceplate

The P_Fanout faceplate consists of three tabs and each tab consists of one or more pages. The Operator tab is displayed when the faceplate is initially opened.

The faceplate contains the value of local configuration tags Cfg_Tag and Cfg_Desc in the title bar.

Tag - Description

Click the appropriate icon at the top of the faceplate to access a specific tab.



The faceplate provides the means for operators, maintenance personnel, engineers, and others to interact with the P_Fanout instruction instance, including viewing its status and values and manipulating it through its commands and settings. When a given input is restricted via FactoryTalk View security, the required user security code letter is shown in the tables that follow.

Operator Tab

The Faceplate initially opens to the Operator ('Home') tab. From here, an operator can monitor the device status and manually operate the device when it is in Operator mode.

If outputs 6, 7, and 8 are not used by the instruction (in other words, if Cfg_HasCV6... Cfg_HasCV8 are 0), the global object opens a smaller faceplate that displays the information for up to five outputs.



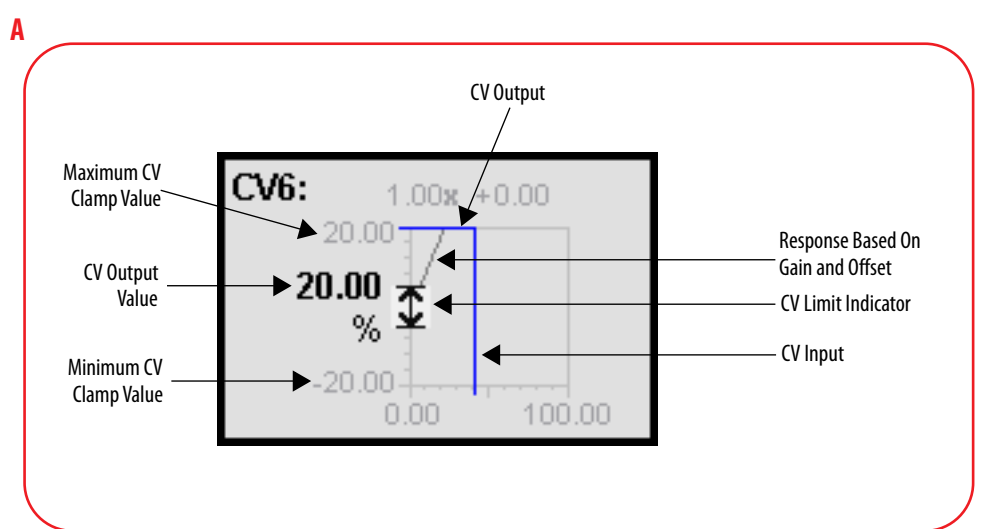
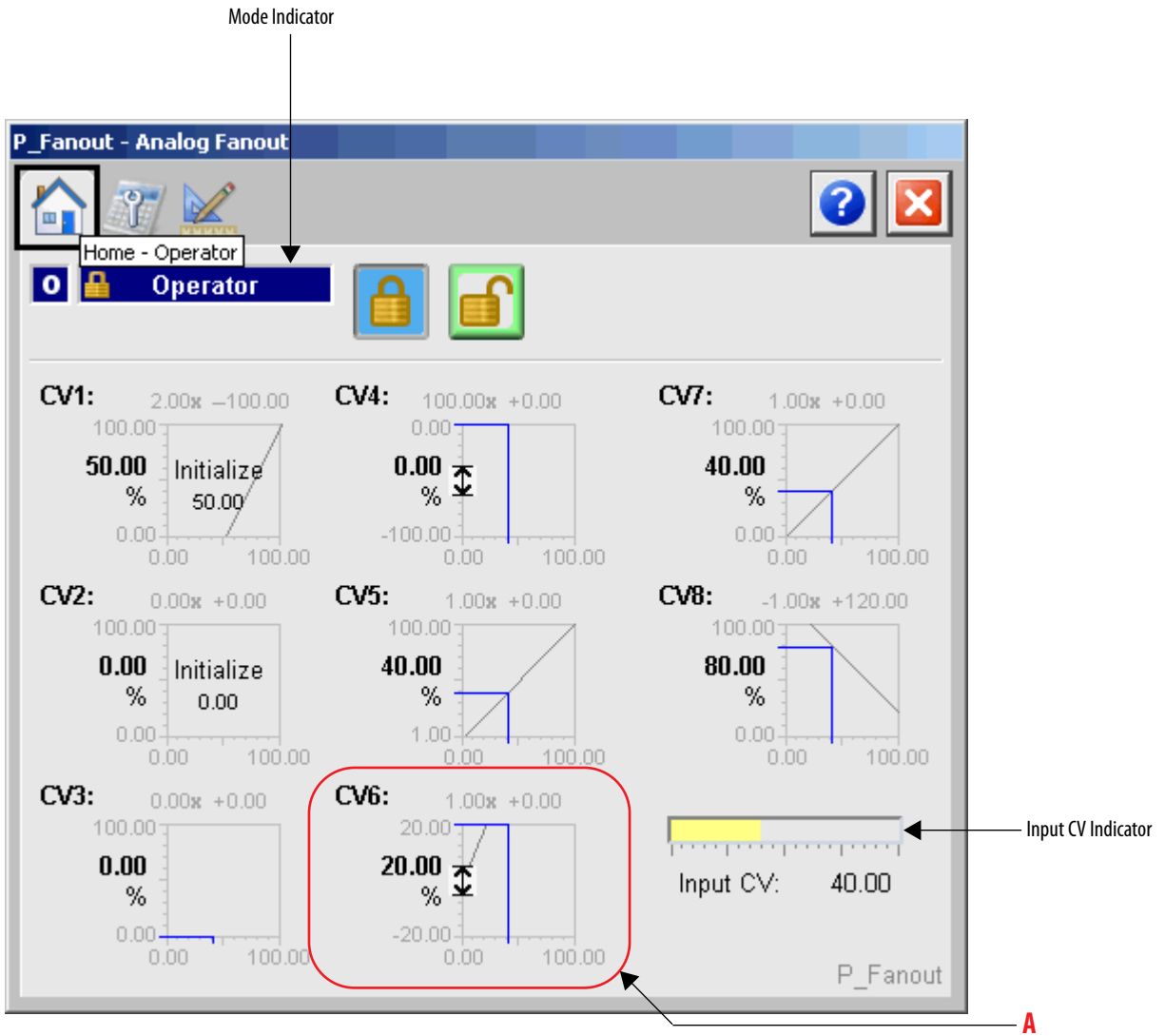

The Operator tab shows the following information:

- Current mode (Operator, Program, or Maintenance)
- Bar graph for the Input CV



The following table shows the functions included on the Operator tab.

Table 11 - Operator Tab Description

Function	Action	Security
	Click to release Operator mode lock.	Manual Device Operation (Code B)
	Click to lock in Operator mode.	
	Click to request Program mode.	
	Click to request Operator mode.	
CV1...CV8	Click to navigate to the input object.	None

Maintenance Tab

Maintenance personnel use the information and controls on the Maintenance tab to adjust device parameters, troubleshoot and temporarily work around device problems, and disable the device for routine maintenance.

The Maintenance tab shows the following information:

- Current mode (Program, Operator, or Maintenance).
- Requested Modes indicator - This display highlights all modes that have been requested. The leftmost highlighted mode is the active mode.

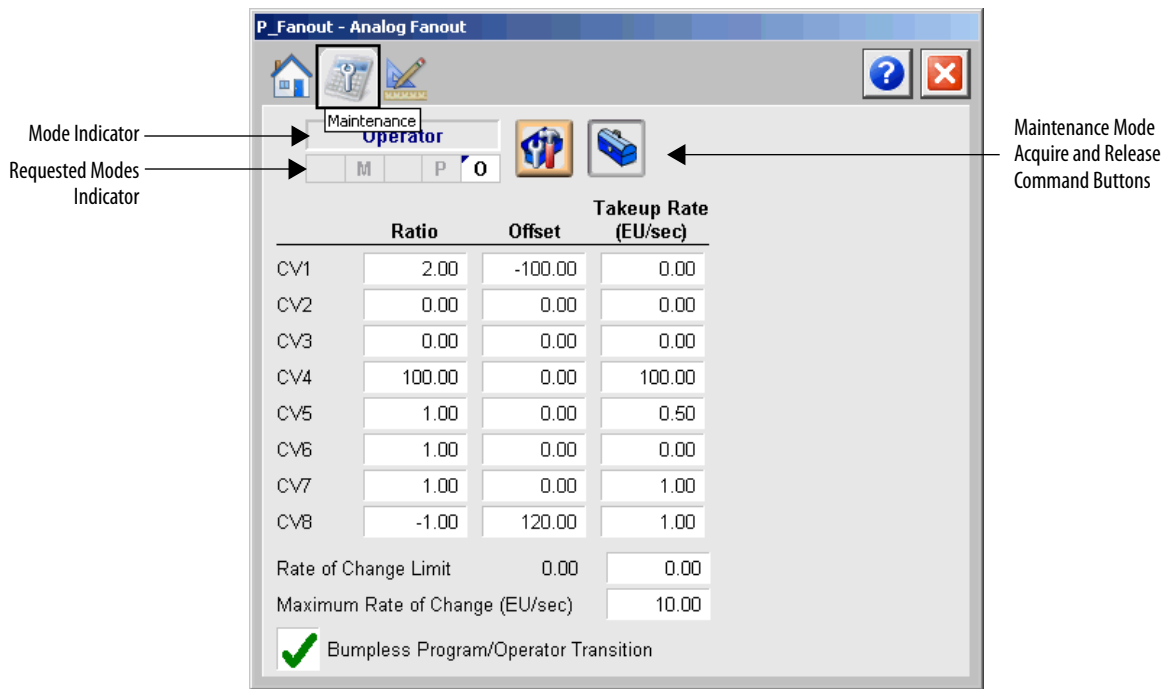

The following table shows the functions on the Maintenance tab.

Table 12 - Maintenance Tab Description



Function	Action	Security	Configuration Parameters
	Click for Maintenance mode.	Equipment Maintenance (Code C)	None
	Click to release Maintenance mode.		
Ratio	Type a value that sets the ratio to calculate each individual output. This either sets the operator ratio (for example, OSet_CV1Ratio) or the configuration ratio (for example, Cfg_CV1Ratio) depending on the ratio source selection.	Normal Operation of Devices (Code A) Configuration and Tuning Maintenance (Code D)	If ratios are set to use configuration (for example, Cfg_CV1RatioSrc = 0), then Cfg_CV1Ratio . . . Cfg_CV8Ratio. Otherwise these fields are linked to OSet parameters (for example, OSet_CV1RatioSrc).

Table 12 - Maintenance Tab Description

Function	Action	Security	Configuration Parameters
Offset	Type a value that sets the offset to calculate each individual output. This either sets the operator offset (for example, OSet_CV10Offset) or the configuration offset (for example, Cfg_CV10Offset) depending on the ratio source selection.	Normal Operation of Devices (Code A) Configuration and Tuning Maintenance (Code D)	If offsets are set to use configuration (for example, (for example, Cfg_CV10OffsetSrc = 0), then Cfg_CV10Offset... Cfg_CV8Offset. Otherwise these fields are linked to OSet parameters (for example, OSet_CV10OffsetSrc).
Takeup Rate (engineering units/sec)	Type a rate the CV is to change to a calculated value after initialization to provide bumpless transfer from initialization.	Configuration and Tuning Maintenance (Code D)	Cfg_CV1TakeupRate... Cfg_CV8 TakeupRate
Rate of Change Limit	Operator setting for the Input CV rate of change limit (increasing or decreasing). If Cfg_MaxCVRoC = 0.0, then this parameter can be set to zero, which means the rate of change is not limited.	Normal Operation of Devices (Code A)	None
Maximum Rate of Change (engineering units/second)	Maximum allowed CV rate of change setting. A value of 0.0 indicates no maximum and rate of change limits can be set to any value ≥ 0.0 .	Configuration and Tuning Maintenance (Code D)	Cfg_MaxCVRoC
Bumpless Program/Operator Transition	When this parameter is: <ul style="list-style-type: none"> ON, the operator settings track the program settings when mode is Program, and program settings track the operator settings when the mode is Operator. Transition between modes is bumpless. OFF, the operator settings and program settings are not modified by this instruction and retain their values regardless of mode. When the mode is changed, the value of a ratio or offset can change, such as from the Program-set value to the Operator-set value. 	Equipment Maintenance (Code C)	Cfg_SetTrack

Engineering Tab

The Engineering tab provides access to device configuration parameters and ranges, options for device and I/O setup, displayed text, and faceplate-to-faceplate navigation settings, and for initial system commissioning or later system changes.

The Engineering tab has four pages.

Engineering Tab Page 1

Page 1 of the Engineering tab shows the description, label, tag, and limit values.

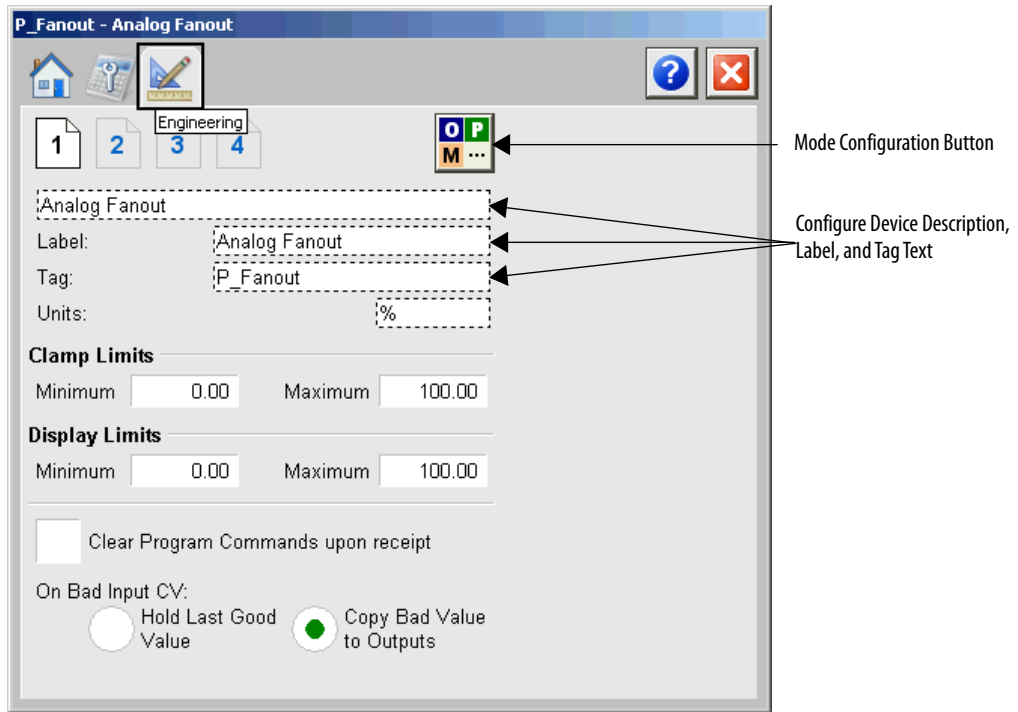

The following table lists the functions on page 1 of the Engineering tab.

Table 13 - Engineering Tab Page 1 Description

Function	Action	Security	Configuration Parameters
	Click to navigate to the Mode Configuration display.	None	See Mode Configuration display on page 37
Description	Type the device description to show on the Faceplate title bar.	Engineering Configuration (Code E)	Cfg_Desc
Label	Type the label to show on the Graphic Symbol.		Cfg_Label

Table 13 - Engineering Tab Page 1 Description

Function	Action	Security	Configuration Parameters
Tag	Type the tag name to show on the Faceplate and Tooltip. IMPORTANT: Pausing the mouse over this field displays a tool tip with the configured Logix tag/path.	Engineering Configuration (Code E)	Cfg_Tag
Units	Type the units that are used with the CV.		Cfg_CV_EU
Clamp Limits Minimum Maximum	Type values to set the limits to use to clamp the CV.		<ul style="list-style-type: none"> Cfg_CVMin Cfg_CVMax
Display Limits Minimum Maximum	Type values to set the limits to display for the CV.		<ul style="list-style-type: none"> Cfg_CVEUMin Cfg_CVEUMax
Clear Program Commands on Receipt	Check to use edge-triggered Program commands (default). Clear the checkbox to use Level-triggered Program commands.		Cfg_PCmdClear
On Bad Input CV: Hold Last Good Value	Click to hold last good value.		Cfg_ShedHold
On Bad Input CV: Copy Bad Values to Outputs	Click to pass through the bad value.		

Mode Configuration Display

This display lets you select the default mode for the object by selecting the appropriate mode.

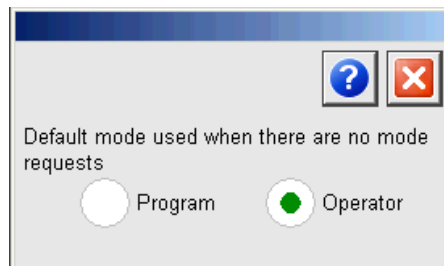
IMPORTANT If no mode is being requested, changing the default mode changes the mode of the instruction.

You must have FactoryTalk View security code E to select the default mode on this display.

Engineering Tab Page 2

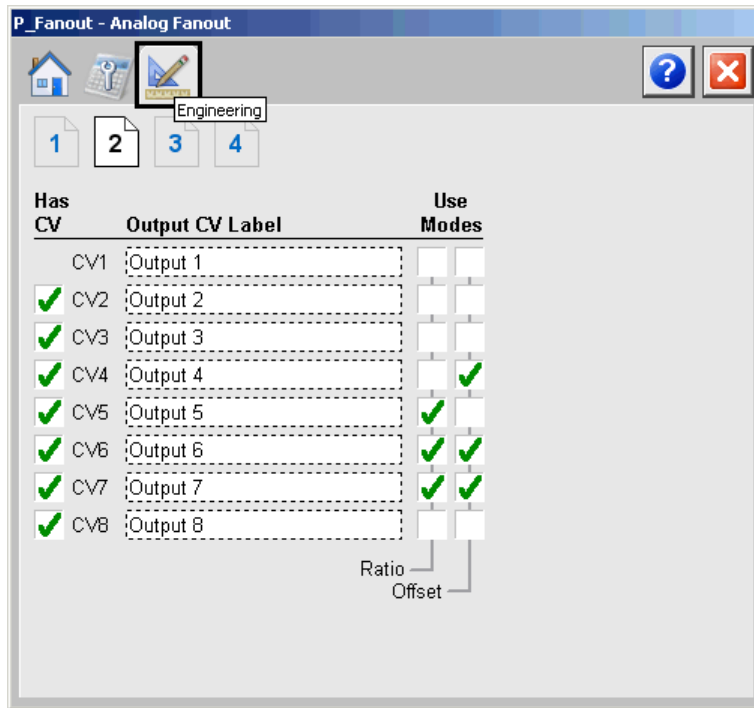

The following table shows the functions on page 2 of the Engineering tab.

Table 14 - Engineering Tab Page 2 Description

Function	Action	Security	Configuration Parameters
Has CV	Check to enable use of the corresponding output.	Engineering Configuration (Code E)	Cfg_HasCV2...Cfg_HasCV8
Output CV Label	Type the description of the output name.		Cfg_CV1_Label...Cfg_CV8_Label
Use Modes - Ratio	Check to use ratio from setting parameters (for example, PSet_CV1Ratio or OSet_CV1Ratio). Clear the checkbox to use ratio from configuration (for example, Cfg_CV1Ratio).		Cfg_CV1RatioSrc...Cfg_CV8RatioSrc
Use Modes - Offset	Check to use offset from setting parameters (for example, PSet_CV1Offset or OSet_CV1Offset). Clear the checkbox to use offset from configuration (for example, Cfg_CV1Offset).		Cfg_CV1OffsetSrc...Cfg_CV8OffsetSrc

Engineering Tab Page 3

	Minimum	Maximum	EU
CV1	0.00	100.00	%
CV2	0.00	100.00	%
CV3	0.00	100.00	%
CV4	-100.00	0.00	%
CV5	1.00	100.00	%
CV6	-20.00	20.00	%
CV7	0.00	100.00	%
CV8	0.00	100.00	%

Initialize Primary Using:

CV1 Initial Value
 Fixed Value

Table 15 - Engineering Tab Page 3 Description

Function	Action	Security	Configuration Parameters
CV Minimum	Type a value for the minimum value to be used to clamp CV (in engineering units).	Engineering Configuration (Code E)	Cfg_CV1Min...Cfg_CV8Min
CV Maximum	Type a value for the maximum value to be used to clamp CV (in engineering units).		Cfg_CV1Max...Cfg_CV8Max
CV engineering units	Sets the CV engineering units to use for display.		Cfg_CV1_EU...Cfg_CV8_EU
Initialize Primary Using: CV1 Initial Value	Click to use the CV1 initialization value (Inp_CV1InitVal) to set the initialization output (Out_CV_InitVal) when initialization is requested.		Cfg_UseFixedInit
Initialize Primary Using: Fixed Value	Click to use a fixed value (Cfg_FixedInitVal) to set the initialization output (Out_CV_InitVal) when initialization is requested. Type a value to set the initialization value (Out_CVInitVal) if initialization is requested and a fixed value option is selected.		<ul style="list-style-type: none"> Cfg_UseFixedInit Cfg_FixedInitVal

Engineering Tab Page 4

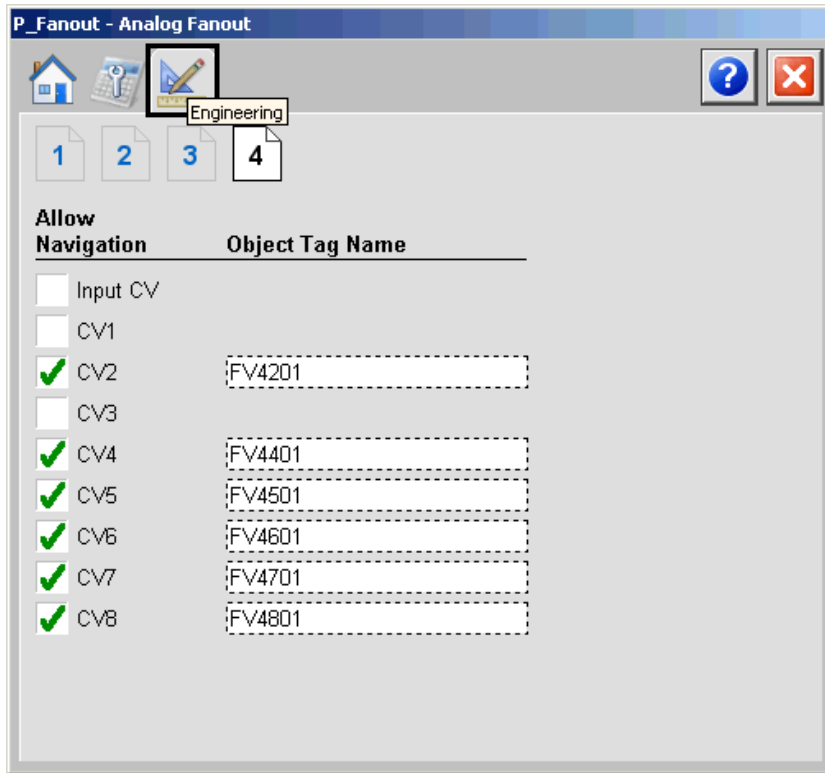
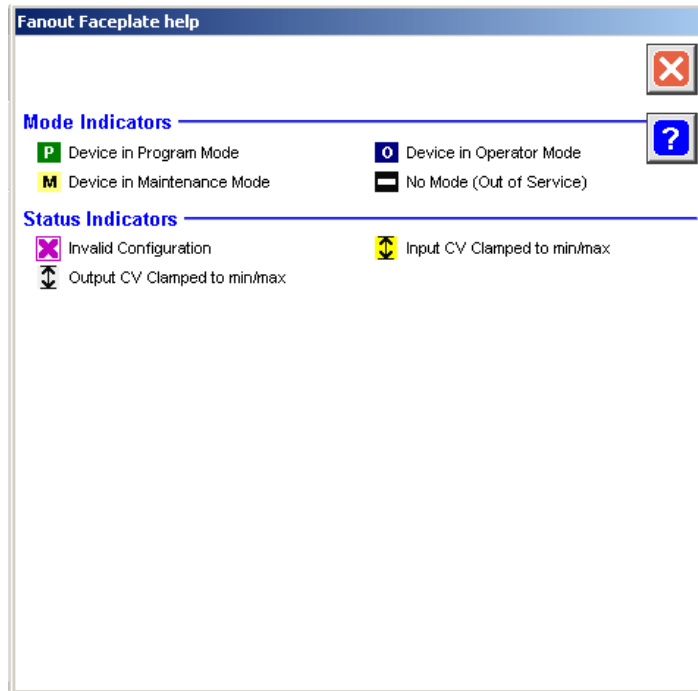

Table 16 - Engineering Tab Page 4 Description

Function	Action	Security	Configuration Parameters
Allow Navigation	Check to permit navigation to a faceplate for which you typed a tag name. For example, 'MyCVObject.'	Engineering Configuration (Code E)	<ul style="list-style-type: none"> • Cfg_HasNav.0...Cfg_HasNav.7 • Cfg_CVNavTag
Object Tag Name	Type the text that is displayed on the HMI.		<ul style="list-style-type: none"> • Cfg_NavTag[0]...[7] • Cfg_CVNavTag

Analog Fanout Faceplate Help



Notes:

Rockwell Automation Support

Rockwell Automation provides technical information on the Web to assist you in using its products.

At <http://www.rockwellautomation.com/support> you can find technical and application notes, sample code, and links to software service packs. You can also visit our Support Center at <https://rockwellautomation.custhelp.com/> for software updates, support chats and forums, technical information, FAQs, and to sign up for product notification updates.

In addition, we offer multiple support programs for installation, configuration, and troubleshooting. For more information, contact your local distributor or Rockwell Automation representative, or visit <http://www.rockwellautomation.com/services/online-phone>.

Installation Assistance

If you experience a problem within the first 24 hours of installation, review the information that is contained in this manual. You can contact Customer Support for initial help in getting your product up and running.

United States or Canada	1.440.646.3434
Outside United States or Canada	Use the Worldwide Locator at http://www.rockwellautomation.com/rockwellautomation/support/overview.page , or contact your local Rockwell Automation representative.

New Product Satisfaction Return

Rockwell Automation tests all of its products to help ensure that they are fully operational when shipped from the manufacturing facility. However, if your product is not functioning and needs to be returned, follow these procedures.

United States	Contact your distributor. You must provide a Customer Support case number (call the phone number above to obtain one) to your distributor to complete the return process.
Outside United States	Please contact your local Rockwell Automation representative for the return procedure.

Documentation Feedback

Your comments will help us serve your documentation needs better. If you have any suggestions on how to improve this document, complete this form, publication [RA-DU002](#), available at <http://www.rockwellautomation.com/literature/>.

Rockwell Automation maintains current product environmental information on its website at <http://www.rockwellautomation.com/rockwellautomation/about-us/sustainability-ethics/product-environmental-compliance.page>.

Rockwell Otomasyon Ticaret A.Ş., Kar Plaza İş Merkezi E Blok Kat:6 34752 İçerenköy, İstanbul, Tel: +90 (216) 5698400

www.rockwellautomation.com

Power, Control and Information Solutions Headquarters

Americas: Rockwell Automation, 1201 South Second Street, Milwaukee, WI 53204-2496 USA, Tel: (1) 414.382.2000, Fax: (1) 414.382.4444
Europe/Middle East/Africa: Rockwell Automation NV, Pegasus Park, De Kleetlaan 12a, 1831 Diegem, Belgium, Tel: (32) 2 663 0600, Fax: (32) 2 663 0640
Asia Pacific: Rockwell Automation, Level 14, Core F, Cyberport 3, 100 Cyberport Road, Hong Kong, Tel: (852) 2887 4788, Fax: (852) 2508 1846

Publication SYSLIB-RM030E-EN-P - February 2017

Supersedes Publication SYSLIB-RM030D-EN-P - January 2016

Copyright © 2017 Rockwell Automation, Inc. All rights reserved. Printed in the U.S.A.