

# Rockwell Automation Library of Process Objects: Discrete 2-, 3-, or 4-state Device (P\_D4SD)

Version 3.5

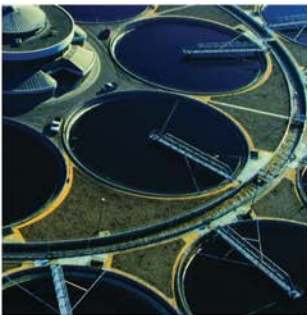
## IMPORTANT

This manual applies to the Rockwell Automation Library of Process Objects version 3.5 or earlier.  
For Rockwell Automation Library of Process Objects version 5.0, see

- [PROCES-RM200](#)

For Rockwell Automation Library of Process Objects version 4.0 or later, use the following manuals:

- [PROCES-RM013](#) contains logic instructions
- [PROCES-RM014](#) contains display elements



## Important User Information

Read this document and the documents listed in the additional resources section about installation, configuration, and operation of this equipment before you install, configure, operate, or maintain this product. Users are required to familiarize themselves with installation and wiring instructions in addition to requirements of all applicable codes, laws, and standards.

Activities including installation, adjustments, putting into service, use, assembly, disassembly, and maintenance are required to be carried out by suitably trained personnel in accordance with applicable code of practice.

If this equipment is used in a manner not specified by the manufacturer, the protection provided by the equipment may be impaired.

In no event will Rockwell Automation, Inc. be responsible or liable for indirect or consequential damages resulting from the use or application of this equipment.

The examples and diagrams in this manual are included solely for illustrative purposes. Because of the many variables and requirements associated with any particular installation, Rockwell Automation, Inc. cannot assume responsibility or liability for actual use based on the examples and diagrams.

No patent liability is assumed by Rockwell Automation, Inc. with respect to use of information, circuits, equipment, or software described in this manual.

Reproduction of the contents of this manual, in whole or in part, without written permission of Rockwell Automation, Inc., is prohibited.

Throughout this manual, when necessary, we use notes to make you aware of safety considerations.



**WARNING:** Identifies information about practices or circumstances that can cause an explosion in a hazardous environment, which may lead to personal injury or death, property damage, or economic loss.



**ATTENTION:** Identifies information about practices or circumstances that can lead to personal injury or death, property damage, or economic loss. Attentions help you identify a hazard, avoid a hazard, and recognize the consequence.

---

### IMPORTANT

Identifies information that is critical for successful application and understanding of the product.

---

Labels may also be on or inside the equipment to provide specific precautions.



**SHOCK HAZARD:** Labels may be on or inside the equipment, for example, a drive or motor, to alert people that dangerous voltage may be present.



**BURN HAZARD:** Labels may be on or inside the equipment, for example, a drive or motor, to alert people that surfaces may reach dangerous temperatures.



**ARC FLASH HAZARD:** Labels may be on or inside the equipment, for example, a motor control center, to alert people to potential Arc Flash. Arc Flash will cause severe injury or death. Wear proper Personal Protective Equipment (PPE). Follow ALL Regulatory requirements for safe work practices and for Personal Protective Equipment (PPE).

---

---

<b>Preface</b>	Software Compatibility and Content Revision.....	5
	Additional Resources.....	5
<b>Discrete 2-, 3-, 4-state Device (P_D4SD)</b>	Guidelines.....	7
	Functional Description.....	8
	Required Files.....	9
	Controller File.....	9
	Visualization Files.....	9
	Controller Code.....	12
	Discrete 2-, 3-, 4-state Device Input Structure.....	12
	Discrete 2-, 3-, or 4-state Device Output Structure.....	16
	Discrete 2-, 3-, or 4-state Device Local Configuration Tags....	20
	Operations.....	21
	Modes.....	21
	Alarms.....	22
	Simulation.....	22
	Execution.....	23
	Programming Example.....	24
	Display Elements.....	28
	Status/Quality Indicators.....	31
	Mode Indicators.....	32
	Alarm Indicators.....	33
	Maintenance Bypass Indicator.....	34
	Using Display Elements.....	35
	Quick Display.....	37
	Faceplate.....	37
	Operator Tab.....	38
	Maintenance Tab.....	42
	Engineering Tab.....	45
	Diagnostics Tab.....	51
	Alarms Tab.....	52
	Discrete 2-, 3-, 4-state Device Faceplate Help.....	54

**Notes:**

## **Software Compatibility and Content Revision**

**Table 1 - Summary of Changes**

<b>Topic</b>	<b>Page</b>
Visualization Files: Global Objects (.ggfx) - Process Diagnostic Objects	10

For the latest compatible software information and to download the Rockwell Automation® Library of Process Objects, see the Product Compatibility and Download Center at <http://www.rockwellautomation.com/rockwellautomation/support/pcdc.page>.

For general library considerations, see Rockwell Automation Library of Process Objects, publication [PROCES-RM002](#).

## Additional Resources

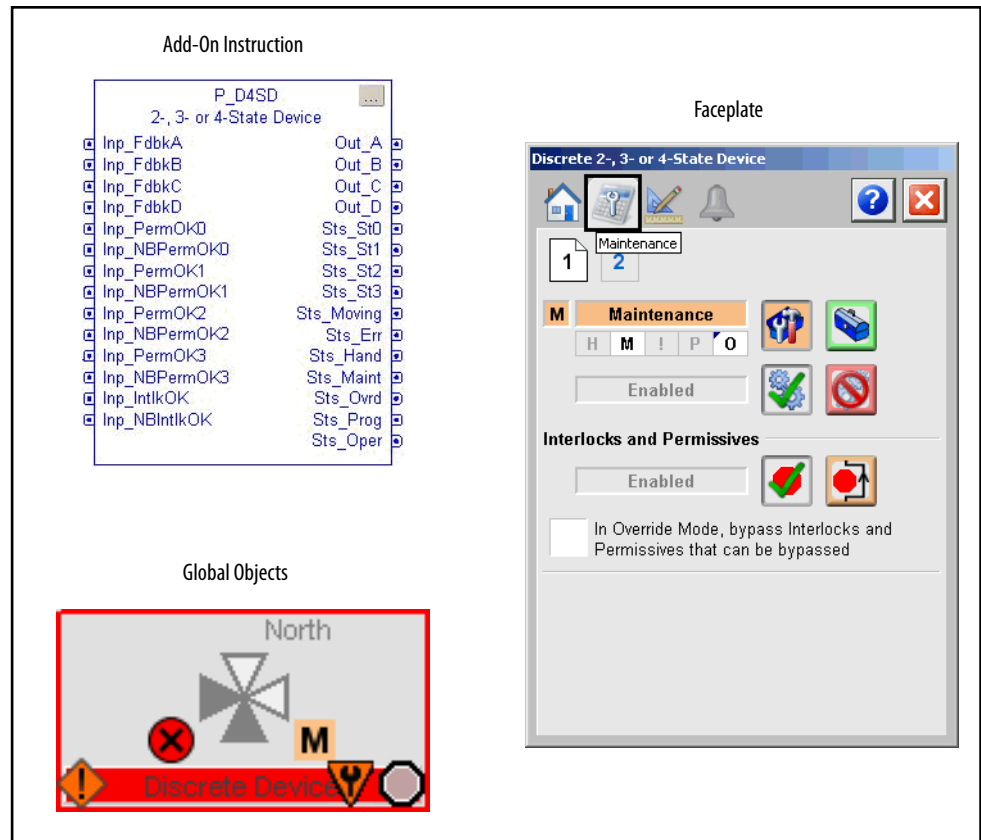
These documents contain additional information concerning related products from Rockwell Automation.

Resource	Description
PlantPAx® Distributed Control System Selection Guide, publication <a href="#">PROCES-SG001</a>	Provides information to assist with equipment procurement for your PlantPAx system.
PlantPAx Distributed Control System Reference Manual, publication <a href="#">PROCES-RM001</a>	Provides characterized recommendations for implementing your PlantPAx system.
Rockwell Automation Library of Process Objects, publication <a href="#">PROCES-RM002</a>	Provides general considerations for the PlantPAx system library of process objects.
FactoryTalk® View Machine Edition User Manual, publication <a href="#">VIEWME-UM004</a>	Provides details on how to use this software package for creating an automation application.
FactoryTalk View SE Edition User Manual, publication <a href="#">VIEWSE-UM006</a>	Provides details on how to use this software package for developing and running human-machine interface (HMI) applications that can involve multiple users and servers, distributed over a network.
Logix5000™ Controllers Add-On Instructions Programming Manual, publication <a href="#">1756-PM010</a>	Provides information for designing, configuring, and programming Add-On Instructions.
Rockwell Automation Library of Process Objects: Common Alarm Block (P_Alarm) Reference Manual, publication <a href="#">SYSLIB-RM002</a>	Details how to monitor an input condition to raise an alarm. Information includes acknowledging, resetting, inhibiting, and disabling an alarm. Generally the P_Alarm faceplate is accessible from the Alarms tab.
Rockwell Automation Library of Process Objects: Interlocks with First Out and Bypass (P_Intlk) Reference Manual, publication <a href="#">SYSLIB-RM004</a>	Explains how to collect (sum up) the interlock conditions that stop or de-energize a running or energized piece of equipment or prevent it from starting or being energized.
Rockwell Automation Library of Process Objects: Common Mode Block (P_Mode) Reference Manual, publication <a href="#">SYSLIB-RM005</a>	Explains how to choose the Mode (owner) of an instruction or control strategy. The Mode instruction is usually embedded within other instructions to extend their functionality. It is possible to use a standalone Mode instruction to enhance a program where modes are wanted.
Rockwell Automation Library of Process Objects: Permissives with Bypass (P_Perm) Reference Manual, publication <a href="#">SYSLIB-RM007</a>	Details how to collect permissive conditions to start a piece of equipment.

You can view or download publications at <http://www.rockwellautomation.com/literature/>. To order paper copies of technical documentation, contact your local Allen-Bradley distributor or Rockwell Automation sales representative.

# Discrete 2-, 3-, 4-state Device (P\_D4SD)

The P\_D4SD (Discrete 2-, 3-, 4-state Device) Add-On Instruction controls and monitors feedback from a discrete 2-state, 3-state, or 4-state device in various modes, monitoring for fault conditions. These devices include multiple-speed motors or multiple-position valves. The global objects and the following faceplate are examples of the graphical interface tools that are used with this instruction.



## Guidelines

Use this instruction in these situations:

- You need to operate a discrete device that has two, three, or four unique states, and the device is not supported by other Rockwell Automation Library of Process Objects Add-On Instructions for various motors, valves, and so forth.
- You have a device, such as a valve or motor, that is supported by other Add-On Instructions, but you want the device to use non-standard state names, such as 'recycle' and 'deliver' for a diverter valve, rather than the fixed names used in the other Instruction, such as 'closed' and 'open'. The P\_D4SD Instruction has configurable names for each of the device states.

Do **not** use this instruction in these situations:

- You need to operate a device that has more than four states, such as a six-position rotary selector valve. You can use the P\_nPos (n-Position Device) Add-On Instruction instead.
- You need to operate a single-speed motor, two-speed motor, simple reversing motor, solenoid valve, motor-operated valve, mix-proof valve, or other device that is better supported by other Rockwell Automation Library of Process Objects Add-On Instructions. Instructions such as P\_Motor, P\_MotorRev, P\_Motor2Spd, P\_ValveSO, P\_ValveMO, and P\_ValveMP more closely model the device under control and can provide better diagnostics for the device.
- You need to operate a continuously-variable device. Use the P\_AOut (Analog Output), P\_ValveC (Control Valve), or P\_VSD (Variable Speed Drive) Add-On Instruction instead.
- You need to operate a two-state device that requires pulsing (single-pulse or continuous). Use the P\_DOut (Discrete Output) Instruction instead.

## Functional Description

The Discrete 2-, 3-, or 4-state Device Add-On Instruction provides the following capabilities:

- Provides configuration to have two, three, or four selectable states for the device.
- Provides Operator and Program Commands to select one of the two, three, or four states of the device.
- Controls four discrete outputs, with configurable states of each output in the various device states. Each output can be set, cleared, or left in last state in a given device state.
- Monitors four discrete feedback inputs, with configurable states (including 'must be on', 'must be off', and 'don't care') for each input in the various device states for monitoring the actual position of the device.
- Provides configurable text labels for each of the states.
- When feedback inputs are used, detects failure to reach the target state, after a configurable time, and alarms the failure. Optionally 'sheds' to the default state (state 0) on a feedback failure.
- Monitors Permissive conditions that allow commanding the device to each state.
- Monitors Interlock conditions that return the device to its default state (state 0).
- Provides simulation of a normal working device, while holding the outputs to the real device de-energized, for use in testing or operator training.
- Monitors I/O communication status, providing an alarm on an I/O fault. Optionally 'sheds' to the default state on an I/O fault condition.
- Provides an 'Available' Status when in Program mode and operating normally for use by automation logic to determine if the logic can manipulate the device.
- Operates in Hand, Maintenance, Override, Program, and Operator modes. (See [Modes on page 20](#).)



## Required Files

Add-On Instructions are reusable code objects that contain encapsulated logic that can streamline implementing your system. This lets you create your own instruction set for programming logic as a supplement to the instruction set provided natively in the ControlLogix® firmware. An Add-On Instruction is defined once in each controller project, and can be instantiated multiple times in your application code as needed.

## Controller File

The P\_D4SD\_3\_5-00\_AOIL5X Add-On Instruction must be imported into the controller project to be used in the controller configuration. The service release number (boldfaced) can change as service revisions are created.

## Visualization Files

This Add-On Instruction has associated visualization files that provide a common user interface. These files can be downloaded from the Product Compatibility and Download Center at <http://www.rockwellautomation.com/rockwellautomation/support/pcdc.page>.

---

<b>IMPORTANT</b>	The visualization file dependencies require Process Library content imports to occur in a specific order as reflected in the following tables: <ul style="list-style-type: none"> <li>• Images</li> <li>• Global Objects</li> <li>• Standard Displays</li> <li>• HMI Tags</li> <li>• Macros</li> </ul>
------------------	--

---

Images are external graphic files that can be used in displays. They must be imported for FactoryTalk View to make use of them.

When PNG files are imported, they are renamed by FactoryTalk View with a .bmp file extension, but retain a .png format.

**Table 2 - Visualization Files: Images (.png)**

FactoryTalk View SE Software	FactoryTalk View ME Software	Description
All .png files in the images folder	All .png files in the images folder	These are the common icons used in the global objects and standard displays for all Process Objects.

The Global Object files (.ggfx file type) in the following table are Process Library display elements that are created once and referenced multiple times on multiple displays in an application. When changes are made to a Global Object, all instances in the application are automatically updated.

**Table 3 - Visualization Files: Global Objects (.ggfx)**

FactoryTalk View SE Software	FactoryTalk View ME Software	Description
(RA-BAS) Common Faceplate Objects	(RA-BAS-ME) Common Faceplate Objects	Global objects used on process object faceplates.
(RA-BAS) P_D4SD Graphics Library	(RA-BAS-ME) P_D4SD Graphics Library	P_D4SD global object device symbols used to build process graphics.
(RA-BAS) P_D4SD Motor Graphics Library	(RA-BAS-ME) P_D4SD Motor Graphics Library	P_D4SD Motor global object device symbols used to build process graphics.
(RA-BAS) Process Alarm Objects	(RA-BAS-ME) Process Alarm Objects	Global objects used for managing alarms on process object faceplates.
(RA-BAS) Process Diagnostic Objects	(RA-BAS-ME) Process Diagnostic Objects	Diagnostic global objects used on process object faceplates.
(RA-BAS) Process Faceplate Misc Objects	(RA-BAS-ME) Process Faceplate Misc Objects	Miscellaneous global objects used on process object faceplates.
(RA-BAS) Process Help Objects	(RA-BAS-ME) Process Help Objects	Global objects used for all process objects help displays.
(RA-BAS) Process Interlock Objects	(RA-BAS-ME) Process Interlock Objects	Global objects used for managing interlocks and permissives on process object faceplates.
(RA-BAS) Process Mode Objects	(RA-BAS-ME) Process Mode Objects	Global objects used for managing modes on process object faceplates.

The Standard Display files (.gfx file type) in the following table are the Process Library displays that you see at runtime.

**Table 4 - Visualization Files: Standard Displays (.gfx)**

FactoryTalk View SE Software	FactoryTalk View ME Software	Description
(RA-BAS) Common-AnalogEdit	N/A	Faceplate used for analog input data entry. The FactoryTalk View ME faceplates use the native analog input data entry so no file is required.
(RA-BAS) P_Alarm-Faceplate	(RA-BAS-ME) P_Alarm-Faceplate	The faceplate that is used for managing alarms for the object.
(RA-BAS) P_Alarm-Help	(RA-BAS-ME) P_Alarm-Help	Alarm Help information that is accessed from the P_Alarm faceplate.
(RA-BAS) P_D4SD-Config	(RA-BAS-ME) P_D4SD-Config	The Configuration Display used to configure the P_D4SD object.
(RA-BAS) P_D4SD-Faceplate	(RA-BAS-ME) P_D4SD-Faceplate	The faceplate that is used for the object
(RA-BAS) P_D4SD-Quick	(RA-BAS-ME) P_D4SD-Quick	The Quick display that is used for the object
(RA-BAS) P_Mode-Config	(RA-BAS-ME) P_Mode-Config	The Configuration Display used to configure the P_Mode object.
(RA-BAS) P_Mode-Help	(RA-BAS-ME) P_Mode-Help	Mode Help information that is accessed from the Help faceplate.
(RA-BAS) Process Discrete Family-Help	(RA-BAS-ME) Process Discrete Family-Help	The Help display for Discrete objects

HMI Tags are created in a FactoryTalk View ME application to support tab switching on Process Library faceplates. The HMI tags may be imported via the comma-separated values file (.csv file type) in the following table.

**Table 5 - Visualization Files: HMI Tags (.csv)**

FactoryTalk View SE Software	FactoryTalk View ME Software	Description
N/A	FTVME_PlantPaxLib_Tags_3_5_XX.csv where XX = the service release number.	These tags must be imported into the FactoryTalk View ME project to support switching tabs on any Process Object faceplate.

## Controller Code

This section describes the parameter references for this Add-On Instruction.

### Discrete 2-, 3-, 4-state Device Input Structure

Input parameters include the following:

- Input data elements (Inp\_) are typically used to connect field inputs from I/O modules or signals from other objects.
- Configuration data elements (Cfg\_) are used to set configurable capabilities and features of the instruction.
- Command data elements (PCmd\_, OCmd\_, MCmd\_) are used by program logic, operators, and maintenance personnel to request instruction actions.
- Setting data elements (PSet\_) are used by program logic to establish runtime setpoints, thresholds, and so forth.

**Table 6 - P\_D4SD Input Parameters**

Input Parameter	Data Type	Alias For	Default	Description
EnableIn	BOOL		1	<p><b>Ladder Diagram:</b> If the rung-in condition is true, the instruction's Logic routine executes. If the rung-in condition is false, the instruction's EnableInFalse routine executes.</p> <p><b>Function Block Diagram:</b> If true, or not connected, the instruction's Logic routine executes. If the parameter is exposed as a pin and wired, and the pin is false, the instruction's EnableInFalse routine executes.</p> <p><b>Structured Text:</b> No effect. The instruction's Logic routine executes.</p>
Inp_FdbkA	BOOL		0	Feedback input signals from device. Use the feedback configuration parameters (for example, Cfg_FdbkSt0Check and Cfg_FdbkSt0State) to determine how these inputs are used to determine actual state.
Inp_FdbkB				
Inp_FdbkC				
Inp_FdbkD				
Inp_DeviceFault	BOOL		0	Input Signal: Device fault from device. 1 = fault
Inp_PermOK0	BOOL		1	1 = Permissives OK, device can be commanded to State 0...3.
Inp_PermOK1				
Inp_PermOK2				
Inp_PermOK3				
Inp_NBPermOK0	BOOL		1	1 = Non-Bypassable Permissives OK, device can be commanded to State 0...3.
Inp_NBPermOK1				
Inp_NBPermOK2				
Inp_NBPermOK3				
Inp_IntlkOK	BOOL		1	1 = Interlocks OK. 0 = Not OK, go to State 0.
Inp_NBIntlkOK	BOOL		1	1 = Non-bypassable Interlocks OK. 0 = Not OK, go to State 0.

**Table 6 - P\_D4SD Input Parameters**

Input Parameter	Data Type	Alias For	Default	Description
Inp_IOFault	BOOL		0	Input Communication Status: 0 = OK 1 = Fail
Inp_Sim	BOOL		0	Simulation input. When set to 1, the instruction simulates a working device while keeping outputs de-energized. When set to 0, the instruction controls the device normally.
Inp_Hand	BOOL	Mode.Inp_Hand	0	1 = Select Hand (hard-wired) mode.
Inp_Ovrd	BOOL	Mode.Inp_Ovrd	0	1 = Select Override mode.
Inp_OvrdCmd	DINT		0	Override mode device command: 0 = None 1 = State 0 2 = State 1 3 = State 2 4 = State 3
Inp_Reset	BOOL		0	Input parameter used to programatically reset alarms. When set to 1, all alarms requiring reset are reset.
Cfg_St0onShed	BOOL		0	1 = Go to State 0 on Shed. 0 = Hold position on Shed.
Cfg_NumStates	DINT		2	Number of device states (2...4).
Cfg_OutSt0Write	SINT		2#0000_1111	These configuration parameters determine how the outputs are used to command state. The parameter Cfg_OutSt[x]Write configures which outputs get written for each state. The parameter Cfg_OutSt[x]State configures what gets written for each state. For example, if all outputs must be set to 0 except Out_A which must be set to 1 to command the device to state 1, then Cfg_OutSt1Write must be 2#0000_1111 and Cfg_OutSt1State must be 2#0000_0001. By default, all four outputs are written in every state, with a single output set to 1 in each state.
Cfg_OutSt0State			2#0000_0001	
Cfg_OutSt1Write			2#0000_1111	
Cfg_OutSt1State			2#0000_0010	
Cfg_OutSt2Write			2#0000_1111	
Cfg_OutSt2State			2#0000_0100	
Cfg_OutSt3Write			2#0000_1111	
Cfg_OutSt3State			2#0000_1000	
Cfg_FdbkSt0Check	SINT		2#0000_0000	These configuration parameters determine how the inputs are used to determine state. The parameter Cfg_FdbkSt[x]Check configures which inputs get checked for each state. The parameter Cfg_FdbkSt[x]State configures the values of the inputs which determine each state. For example, if the device returns a 0 to Inp_FdbkA and Inp_FdbkB and a 1 to Inp_FdbkC when the device is in state 3, then Cfg_FdbkSt3Check must be 2#0000_0111 and Cfg_FdbkSt1Write must be 2#0000_0100. By default, all inputs are 'don't care' in every state (no feedback checking).
Cfg_FdbkSt0State			2#0000_0001	
Cfg_FdbkSt1Check			2#0000_0000	
Cfg_FdbkSt1State			2#0000_0010	
Cfg_FdbkSt2Check			2#0000_0000	
Cfg_FdbkSt2State			2#0000_0100	
Cfg_FdbkSt3Check			2#0000_0000	
Cfg_FdbkSt3State			2#0000_1000	
Cfg_HasPerm0Obj	BOOL		0	1 = Tells HMI a permissive object (for example, P_Perm) is used for Inp_PermOK0....3 and navigation to the channel object's faceplate is enabled. <b>IMPORTANT:</b> The name of the Permissives object in the controller must be this object's name with the suffix '_Perm#', where '#' is the permissive number (0...3) For example, if your P_D4SD object has the name 'D4SD123', then its Permissives object must be named 'D4SD123_Perm0'.
Cfg_HasPerm1Obj				
Cfg_HasPerm2Obj				
Cfg_HasPerm3Obj				
Cfg_HasIntlkObj	BOOL		0	1 = Tells HMI an interlock object (for example, P_Intlk) is used for Inp_IntlkOK and navigation to the interlock object's faceplate is enabled. <b>IMPORTANT:</b> The name of the interlock object in the controller must be this object's name with the suffix '_Intlk'. For example, if your P_D4SD object has the name 'D4SD123', then its interlock object must be named 'D4SD123_Intlk'.

Table 6 - P\_D4SD Input Parameters

Input Parameter	Data Type	Alias For	Default	Description
Cfg_PCcmdClear	BOOL	Mode.Cfg_PCcmdClear	1	When this parameter is 1, program commands are cleared once they are acted upon. When set to 0, program commands remain set until cleared by the application program logic. <b>IMPORTANT:</b> Clearing this parameter online can cause unintended program command execution.
Cfg_ProgDefault	BOOL	Mode.Cfg_ProgDefault	0	This parameter defines the default mode. When this parameter is 1, the mode defaults to Program if no mode is being requested. When this parameter is 0, the mode defaults to Operator if no mode is being requested. <b>IMPORTANT:</b> Changing this parameter online can cause unintended mode changes.
Cfg_OperSt0Prio	BOOL		0	1 = 0Cmd_St0 has priority, accepted any time 0 = 0Cmd_St0 only in Operator or Maintenance Mode.
Cfg_0CmdResets	BOOL		0	1 = New Operator state command resets fault. 0 = Reset required to clear fault.
Cfg_OvrdrPermlntlk	BOOL		0	1 = Override mode ignores Bypassable Permissives/Interlocks. 0 = Override mode uses Bypassable Permissives/Interlocks.
Cfg_ShedOnFail	BOOL		1	1 = Go to shed state and alarm on Fail to reach position, Device fault, or I/O fault. 0 = Alarm only on fail, Device fault, or I/O fault. Shed state is determined by configuration parameter Cfg_St0onShed.
Cfg_ShedOnDeviceFault				
Cfg_ShedOnIOFault				
Cfg_HasFailAlm	BOOL	Fail.Cfg_Exists	0	1 = Fail to Reach State alarm, Device Fault alarm, Interlock Trip alarm, and I/O Fault alarm exist and are checked.
Cfg_HasDeviceFaultAlm		DeviceFault.Cfg_Exists		
Cfg_HasIntlkTripAlm		IntlkTrip.Cfg_Exists		
Cfg_HasIOFaultAlm		IOFault.Cfg_Exists		
Cfg_FailResetReqd	BOOL	Fail.Cfg_ResetReqd	0	These parameters determine whether a reset is required to clear the alarm status. When these parameters are 1, the alarm is latched On when the alarm occurs. After the alarm condition returns to normal, a reset is required to clear the alarm status (for example, 0Cmd_Reset, Inp_Reset, or Fail.0Cmd_Reset is required to clear the Fail alarm after the alarm is set and the value returns to normal). When these parameters are 0, no reset is required and the alarm status is cleared when the alarm condition returns to normal. <b>IMPORTANT:</b> If the reset clears the alarm, it also acknowledges the alarm.
Cfg_DeviceFaultResetReqd		DeviceFault.Cfg_ResetReqd		
Cfg_IntlkTripResetReqd		IntlkTrip.Cfg_ResetReqd		
Cfg_IOFaultResetReqd		IOFault.Cfg_ResetReqd		
Cfg_FailAckReqd	BOOL	Fail.Cfg_AckReqd	1	These parameters determine whether an acknowledgement is required for an alarm. When these parameters are 1, the acknowledge (ack) bit is cleared when the alarm occurs. An acknowledge command (for example, PCmd_FailAck or Fail.0Cmd_Ack) is required to acknowledge the alarm. When set to 0, the Acknowledge bit is set when an alarm occurs indicating an acknowledged alarm and no acknowledge command is required.
Cfg_DeviceFaultAckReqd		DeviceFault.Cfg_AckReqd		
Cfg_IntlkTripAckReqd		IntlkTrip.Cfg_AckReqd		
Cfg_IOFaultAckReqd		IOFault.Cfg_AckReqd		
Cfg_FailSeverity	INT	Fail.Cfg_Severity	1000	These parameters determine the severity of each alarm. This drives the color and symbol that are used to indicate alarm status on the faceplate and global object. The following are valid values: 1...250 = Low 251...500 = Medium 501...750 = High 751...1000 = Urgent <b>IMPORTANT:</b> For FactoryTalk View software version 7.0, these severity parameters drive only the indication on the global object and faceplate. The Alarms and Events definition of severity drives the color and symbol that is used on the alarm banner and alarm summary as well as the value returned by FactoryTalk Alarms and Events display commands.
Cfg_DeviceFaultSeverity		DeviceFault.Cfg_Severity	1000	
Cfg_IntlkTripSeverity		IntlkTrip.Cfg_Severity	500	
Cfg_IOFaultSeverity		IOFault.Cfg_Severity	1000	

**Table 6 - P\_D4SD Input Parameters**

Input Parameter	Data Type	Alias For	Default	Description
Cfg_OutAPulseT	REAL		0.0	Time to pulse Output A...D (s) (0=output held continuously).
Cfg_OutBPulseT				
Cfg_OutCPulseT				
Cfg_OutDPulseT				
Cfg_SimFdbkT	DINT		2	Delay to echo back reaching state when in simulation (seconds).
Cfg_FailT	DINT		10	Time after new state requested to reach that state before fault (seconds).
PSet_Owner	DINT		0	Program owner request ID (non-zero) or release (zero).
PCmd_St0	BOOL		0	When Cfg_PCmdClear is 1: <ul style="list-style-type: none"> <li>Set PCmd_St0 to 1 to set the device to State 0</li> <li>Set PCmd_St1 to 1 to set the device to State 1</li> <li>Set PCmd_St2 to 1 to set the device to State 2</li> <li>Set PCmd_St3 to 1 to set the device to State 3</li> <li>These parameters reset automatically</li> </ul> When Cfg_PCmdClear is 0: <ul style="list-style-type: none"> <li>State 0 is the default State; PCmd_St0 is not used</li> <li>Set PCmd_St1, PCmd_St2, and PCmd_St3 to 0 to set the device to State 0</li> <li>Set PCmd_St1 to 1 to set the device to State 1</li> <li>Set PCmd_St2 to 1 to set the device to State 2</li> <li>Set PCmd_St3 to 1 to set the device to State 3</li> <li>These parameters do not reset automatically</li> </ul>
PCmd_St1				
PCmd_St2				
PCmd_St3				
PCmd_Acq	BOOL	Mode.PCmd_Acq	0	When Cfg_PCmdClear is 1: <ul style="list-style-type: none"> <li>Set PCmd_Acq to 1 to Acquire</li> <li>Set PCmd_Rel to 1 to Release</li> <li>These parameters reset automatically</li> </ul> When Cfg_PCmdClear is 0: <ul style="list-style-type: none"> <li>Set PCmd_Acq to 1 to Acquire</li> <li>Set PCmd_Acq to 0 to Release</li> <li>PCmd_Rel is not used</li> <li>These parameters do not reset automatically</li> </ul>
PCmd_Rel		Mode.PCmd_Rel		
PCmd_Lock	BOOL	Mode.PCmd_Lock	0	When Cfg_PCmdClear is 1: <ul style="list-style-type: none"> <li>Set PCmd_Lock to 1 to Lock</li> <li>Set PCmd_Unlock to 1 to Unlock</li> <li>These parameters reset automatically</li> </ul> When Cfg_PCmdClear is 0: <ul style="list-style-type: none"> <li>Set PCmd_Lock to 1 to Lock</li> <li>Set PCmd_Lock to 0 to Unlock</li> <li>PCmd_Unlock is not used</li> <li>These parameters do not reset automatically</li> </ul>
PCmd_Unlock		Mode.PCmd_Unlock		
PCmd_Reset	BOOL		0	<ul style="list-style-type: none"> <li>Set PCmd_Reset to 1 to reset all alarms requiring reset</li> <li>This parameter is always reset automatically</li> </ul>
PCmd_FailAck	BOOL	Fail.PCmd_Ack	0	<ul style="list-style-type: none"> <li>Set PCmd_&lt;Alarm&gt;Ack to 1 to Acknowledge alarm</li> <li>The parameter is reset automatically</li> </ul>
PCmd_DeviceFaultAck		DeviceFault.PCmd_Ack		
PCmd_IntlkTripAck		IntlkTrip.PCmd_Ack		
PCmd_IOFaultAck		IOFault.PCmd_Ack		

**Table 6 - P\_D4SD Input Parameters**

Input Parameter	Data Type	Alias For	Default	Description
PCmd_FailSuppress	BOOL	Fail.PCmd_Suppress	0	When Cfg_PCmdClear is 1: <ul style="list-style-type: none"> <li>Set PCmd_&lt;Alarm&gt;Suppress to 1 to suppress alarm</li> <li>Set PCmd_&lt;Alarm&gt;Unsuppress to 1 to unsuppress alarm</li> <li>These parameters reset automatically</li> </ul> When Cfg_PCmdClear is 0: <ul style="list-style-type: none"> <li>Set PCmd_&lt;Alarm&gt;Suppress to 1 to suppress alarm</li> <li>Set PCmd_&lt;Alarm&gt;Suppress to 0 to unsuppress alarm</li> <li>PCmd_&lt;Alarm&gt;Unsuppress is not used</li> <li>These Parameters do not reset automatically</li> </ul>
PCmd_DeviceFaultSuppress		DeviceFault.PCmd_Suppress		
PCmd_IntlkTripSuppress		IntlkTrip.PCmd_Suppress		
PCmd_IOFaultSuppress		IOFault.PCmd_Suppress		
PCmd_FailUnsuppress	BOOL	Fail.PCmd_Unsuppress	0	
PCmd_DeviceFaultUnsuppress		DeviceFault.PCmd_Unsuppress		
PCmd_IntlkTripUnsuppress		IntlkTrip.PCmd_Unsuppress		
PCmd_IOFaultUnsuppress		IOFault.PCmd_Unsuppress		
PCmd_FailUnshelve	BOOL	Fail.PCmd_Unshelve	0	<ul style="list-style-type: none"> <li>Set PCmd_&lt;Alarm&gt;Unshelve to 1 to Unshelve alarm</li> <li>The parameter is reset automatically</li> </ul>
PCmd_DeviceFaultUnshelve		DeviceFault.PCmd_Unshelve		
PCmd_IntlkTripUnshelve		IntlkTrip.PCmd_Unshelve		
PCmd_IOFaultUnshelve		IOFault.PCmd_Unshelve		
OCmd_St0	BOOL		0	Operator command to set device to State 0...3.
OCmd_St1				
OCmd_St2				
OCmd_St3				
OCmd_Bypass	BOOL		0	Operator command to bypass all bypassable Interlocks and Permissives.
OCmd_Check	BOOL		0	Operator command to check (not bypass) all Interlocks and Permissives.
MCmd_Disable	BOOL		0	Maintenance command to disable device.
MCmd_Enable	BOOL		0	Maintenance command to enable device.
MCmd_Acq	BOOL	Mode.MCmd_Acq	0	Maintenance Command to Acquire Ownership (Operator/Program/Override to Maintenance)
MCmd_Rel	BOOL	Mode.MCmd_Rel	0	Maintenance Command to Release Ownership (Maintenance to Operator/Program/Override)
OCmd_AcqLock	BOOL	Mode.OCmd_AcqLock	0	Operator Command to Acquire (Program to Operator) /Lock Ownership
OCmd_Unlock	BOOL	Mode.OCmd_UnlockRel	0	Operator Command to Unlock/Release (Operator to Program) Ownership
OCmd_Reset	BOOL		0	Operator command to reset all alarms requiring reset and any latched shed conditions.
OCmd_ResetAckAll	BOOL		0	Operator command to reset and acknowledge all alarms and reset any latched shed conditions.

## Discrete 2-, 3-, or 4-state Device Output Structure

Output parameters include the following:

- Output data elements (Out\_) are the primary outputs of the instruction, typically used by hardware output modules; however, they can be used by other application logic.
- Value data elements (Val\_) are numeric outputs of the instruction for use by the HMI. Values can also be used by other application logic or software packages.

- Source and Quality data elements (SrcQ\_) are outputs of the instruction used by the HMI to indicate PV source and quality.
- Status data elements (Sts\_) are bit outputs of the instruction for use by the HMI. Status bits can also be used by other application logic.
- Error data elements (Err\_) are outputs of the instruction that indicate a particular configuration error. If any Err\_bit is set, then the Sts\_Err configuration error summary status is set and the Invalid Configuration indicator is displayed on the HMI.
- Not Ready data elements (Nrdy\_) are bit outputs of the instruction for use by the HMI for displaying the Device Not Ready indicator. Not Ready bits can also be used by other application logic.
- Alarm data elements (Alm\_) are outputs of the instruction that indicate a particular alarm has occurred.
- Acknowledge data elements (Ack\_) are outputs of the instruction that indicate the corresponding alarm has been acknowledged.
- Ready data elements (Rdy\_) are bit outputs of the instruction used by the HMI to enable or disable command buttons and set data entry fields.

**Table 7 - P\_D4SD Output Parameters**

Output Parameter	Data Type	Alias For	Description
EnableOut	BOOL		Enable Output: The EnableOut signal is not manipulated by this instruction. Its output state always reflects EnableIn Input state.
Out_A	BOOL		Outputs A...D to device.
Out_B			
Out_C			
Out_D			
SrcQ_IO	SINT		I/O signal source and quality.
SrcQ			Final Device state source and quality. GOOD    0 = I/O live and confirmed good quality 1 = I/O live and assumed good quality 2 = No feedback configured, assumed good quality TEST     8 = Device simulated 9 = Device loopback simulation 10 = Manually entered value UNCERTAIN 16 = Live input, off-specification 17 = Value substituted at device/bus 18 = Value substituted by maintenance (Has and not Use) 19 = Shed, using last good value 20 = Shed, using replacement value BAD      32 = Signal failure (out-of-range, NaN, invalid combination) 33 = I/O channel fault 34 = I/O module fault 35 = Bad I/O configuration (for example, scaling parameters)
Val_Cmd	SINT		Device command: 0 = None 1 = State 0 2 = State 1 3 = State 2 4 = State 3



**Table 7 - P\_D4SD Output Parameters**

Output Parameter	Data Type	Alias For	Description
Val_Sts	SINT		Device confirmed status: 0 = Powerup/Reset 1 = State 0 2 = State 1 3 = State 2 4 = State 3 9 = Moving 33 = Disabled
Val_Fault	SINT		Device fault status: 0 = None 16 = Position Fail 17 = Device Fault 32 = I/O Fault 34 = Configuration Error
Val_Mode	SINT	Mode.Val	The current mode is shown with status bits and also as an enumeration 'Val_Mode' as follows: 0 = No mode 1 = Hand 2 = Maintenance 3 = Override 4 = Program (locked) 5 = Operator (locked) 6 = Program (unlocked, Operator is default) 7 = Operator (unlocked, Program is default) 8 = Program (unlocked, Program is default) 9 = Operator (unlocked, Operator is default)
Val_Owner	DINT		Current object owner ID (0 = not owned).
Val_Notify	SINT		Current alarm level and acknowledgement (enumeration): 0 = No alarm 1 = Alarm cleared: a reset or acknowledge is required 2 = Low (acknowledged) 3 = Low (unacknowledged) 4 = Medium (acknowledged) 5 = Medium (unacknowledged) 6 = High (acknowledged) 7 = High (unacknowledged) 8 = Urgent (acknowledged) 9 = Urgent (unacknowledged)
Sts_St0	BOOL		1 = Device commanded to and confirmed in State 0...3.
Sts_St1			
Sts_St2			
Sts_St3			
Sts_Moving	BOOL		1 = Device not yet confirmed in commanded state.
Sts_Available	BOOL		1 = Device available for control by automation (Program).
Sts_Bypass	BOOL		1 = Bypassable interlocks and permissives are bypassed.
Sts_BypActive	BOOL		1 = Interlock / permissive bypassing active (Bypassed or Maintenance mode).
Sts_Disabled	BOOL		1 = Device is disabled.
Sts_NotRdy	BOOL		1 = Device is not ready to be operated.

**Table 7 - P\_D4SD Output Parameters**

Output Parameter	Data Type	Alias For	Description
Nrды_Disabled	BOOL		1 = Device Not Ready:
Nrды_CfgErr			<ul style="list-style-type: none"> <li>• Device disabled by Maintenance</li> <li>• Configuration error</li> <li>• Interlock not OK</li> <li>• Permissive not OK</li> <li>• Operator State 0 priority command requires reset</li> <li>• Device failure (Shed requires reset)</li> <li>• I/O Fault (Shed requires reset)</li> <li>• External Equipment Fault (fault or shed requires reset)</li> <li>• Device logic disabled/no mode</li> </ul>
Nrды_Intlk			
Nrды_Perm			
Nrды_OperPrio			
Nrды_Fail			
Nrды_IOFault			
Nrды_EqpFault			
Nrды_NoMode			
Sts_MaintByp	BOOL		1 = Device has a Maintenance Bypass function active.
Sts_Almlnh	BOOL		1 = One or more alarms shelved, disabled, or suppressed.
Sts_Err	BOOL		1 = Error in configuration: see detail bits for reason.
Err_Timer	BOOL		1 = Error in configuration: feedback check timer preset (use 0...2,147,483 seconds).
Err_Sim	BOOL		1 = Error in configuration: simulation timer preset (use 0...2,147,483 seconds).
Err_Alarm	BOOL		1 = Error in configuration: alarm minimum on time or severity.
Sts_Hand	BOOL	Mode.Sts_Hand	1 = Mode is Hand (supersedes Operator, Program, Override, Maintenance).
Sts_Maint	BOOL	Mode.Sts_Maint	1 = Mode is Maintenance (supersedes Override, Program, Operator).
Sts_Ovrd	BOOL	Mode.Sts_Ovrd	1 = Mode is Override (supersedes Program, Operator).
Sts_Prog	BOOL	Mode.Sts_Prog	1 = Mode is Program (auto).
Sts_Oper	BOOL	Mode.Sts_Oper	1 = Mode is Operator (manual).
Sts_ProgOperLock	BOOL	Mode.Sts_ProgOperLock	1 = Program or Operator has requested Mode Lock.
Sts_NoMode	BOOL	Mode.Sts_NoMode	1 = No mode (disabled because EnableIn is false).
Sts_MAcqRcvd	BOOL	Mode.Sts_MAcqRcvd	1 = Maintenance Acquire command received this scan
Sts_Fail	BOOL	Fail.Inp	1 = Device failed to reach commanded state (one-shot).
Sts_DeviceFault		DeviceFault.Inp	1 = Device fault (from Inp_DeviceFault).
Sts_IntlkTrip		IntlkTrip.Inp	1 = Device commanded to State 0 by an Interlock NOT OK (one-shot).
Sts_IOFault		IOFault.Inp	I/O communication fault status: 0 = OK 1 = Bad
Alm_Fail	BOOL	Fail.Alm	1 = Alarm: Device failed to reach commended state.
Alm_DeviceFault		DeviceFault.Alm	1 = Device fault alarm.
Alm_IntlkTrip		IntlkTrip.Alm	1 = Alarm: Device set to State 0 by an Interlock NOT OK.
Alm_IOFault		IOFault.Alm	1 = I/O fault alarm.
Ack_Fail	BOOL	Fail.Ack	1 = Fail to reach commanded state alarm has been acknowledged.
Ack_DeviceFault		DeviceFault.Ack	1 = Device fault alarm has been acknowledged.
Ack_IntlkTrip		IntlkTrip.Ack	1 = Interlock Trip alarm has been acknowledged.
Ack_IOFault		IOFault.Ack	1 = I/O fault alarm has been acknowledged.

**Table 7 - P\_D4SD Output Parameters**

Output Parameter	Data Type	Alias For	Description
Sts_FailDisabled	BOOL	Fail.Disabled	1 = Fail to reach commanded state alarm is disabled by Maintenance.
Sts_DeviceFaultDisabled		DeviceFault.Disabled	1 = Device fault alarm has been disabled by Maintenance.
Sts_IntlkTripDisabled		IntlkTrip.Disabled	1 = Interlock Trip alarm is disabled by Maintenance.
Sts_IOFaultDisabled		IOFault.Disabled	1 = I/O fault alarm is disabled by Maintenance.
Sts_FailShelved	BOOL	Fail.Shelved	1 = Fail to reach commanded state Alarm is shelved by Operator.
Sts_DeviceFaultShelved		DeviceFault.Shelved	1 = Device fault alarm is shelved by Operator.
Sts_IntlkTripShelved		IntlkTrip.Shelved	1 = Interlock Trip Alarm is shelved by Operator.
Sts_IOFaultShelved		IOFault.Shelved	1 = I/O fault alarm is shelved by Operator.
Sts_FailSuppressed	BOOL	Fail.Suppressed	1 = Fail to reach commanded state Alarm is suppressed by Program.
Sts_DeviceFaultSuppressed		DeviceFault.Suppressed	1 = Device fault alarm is suppressed by Program.
Sts_IntlkTripSuppressed		IntlkTrip.Suppressed	1 = Interlock Trip Alarm is suppressed by Program.
Sts_IOFaultSuppressed		IOFault.Suppressed	1 = I/O fault alarm is suppressed by Program.
Rdy_St0	BOOL		1 = Ready to receive OCmd_St0...St3 (enables HMI button).
Rdy_St1			
Rdy_St2			
Rdy_St3			
Rdy_Bypass	BOOL		1 = Ready to receive OCmd_Bypass (enables HMI button).
Rdy_Check	BOOL		1 = Ready to receive OCmd_Check (enables HMI button).
Rdy_Disable	BOOL		1 = Ready to receive MCmd_Disable (enables HMI button).
Rdy_Enable	BOOL		1 = Ready to receive MCmd_Enable (enables HMI button).
Rdy_Reset	BOOL		1 = At least one alarm or latched shed requires reset.
Rdy_ResetAckAll	BOOL		1 = At least one alarm or latched shed condition requires reset or acknowledged.
P_D4SD	BOOL		Unique parameter name for auto-discovery.

## Discrete 2-, 3-, or 4-state Device Local Configuration Tags

Configuration parameters that are array, string, or structure data types cannot be configured as parameters for Add-On Instructions. Configuration parameters of these types appear as local tags to the Add-On Instruction. Local tags can be configured through the HMI faceplates or in Studio 5000 Logix Designer® application by opening the Instruction Logic of the Add-On Instruction instance and then opening the Data Monitor on a local tag. These parameters cannot be modified by using controller logic or Logix Designer application export/import functionality.

**Table 8 - Local Configuration Tags**

Tag Name	Data Type	Default	Description
Cfg_Desc	STRING_40	'Discrete 2, 3 or 4 state Device'	Description for display on HMI. This string is shown in the title bar of the faceplate.
Cfg_Label	STRING_20	'Discrete Device'	Label for graphic symbol displayed on HMI. This string appears on the graphic symbol.

**Table 8 - Local Configuration Tags**

Cfg_St0Text	STRING_8	'Off'	Text to display in State 0...3.
Cfg_St1Text		'On'	
Cfg_St2Text		''	
Cfg_St3Text		''	
Cfg_Tag	STRING_20	'P_D4SD'	Tagname for display on HMI. This string is shown in the title bar of the faceplate.

## Operations

This section describes the primary operations for this Add-On Instruction.

### Modes

This instruction uses the following standard modes, which are implemented by using an embedded P\_Mode Add-On Instruction.

**Table 9 - Modes**

Mode	Description
Operator	The Operator owns control of the device. Operator commands (OCmd_) and Operator settings (OSet_) from the HMI are accepted.
Program	Program logic owns control of the device. Program commands (PCmd_) and Program settings (PSet_) are accepted.
Override	Priority logic owns control of the device and supersedes Operator and Program control. Override Inputs (Inp_OvrCmd and other Inp_OvrDxxx values) are accepted. If so configured, bypassable interlocks and permissives are bypassed.
Maintenance	Maintenance owns control of the device and supersedes Operator, Program, and Override control. Operator commands and settings from the HMI are accepted. Bypassable interlocks and permissives are bypassed, and device timeout checks are not processed.
Hand	Hardwired logic or other logic outside the instruction owns control of the device. The instruction tracks the state of the device for bumpless transfer back to one of the other modes.
No Mode	The device is disabled and has no owner because the EnableIn input is false. The main instruction Logic routine is not being scanned. See Execution section for more information on EnableInFalse processing.

See Rockwell Automation Library of Process Objects: Common Mode Block (P\_Mode) Reference Manual, publication [SYSLIB-RM005](#), for more information.

## Alarms

Click an alarm name to open the P\_Alarm faceplate for that alarm. From the P\_Alarm faceplate, you can configure and perform additional operations on the alarm.



If an alarm is active, the panel behind the alarm changes color to match the severity of the alarm. The color of the bell icon at the top of the faceplate shows the severity of the highest active alarm, and the icon blinks if any alarm is unacknowledged or requires reset.

**Table 10 - Alarm Severity Colors**

Color	Definition
Magenta	Urgent
Red	High
Yellow	Medium
Blue	Low
White (bell icon)	Alarm has cleared but is unacknowledged
Background (Light Gray)	No alarm

The following table shows the functions on the Alarms tab.

**Table 11 - Alarms Tab Description**

Function	Action	Security
Alarm Name	Click an alarm name to open the associated P_Alarm faceplate.	None
	Click to acknowledge the alarm.	Acknowledge Alarms (Code F)
	Click to reset and acknowledge all alarms.	


When the Reset and Acknowledge All Alarms button is enabled, the panel behind the alarm blinks, indicating the alarm requires acknowledgement or reset. The Alarm Acknowledge button is enabled if the alarm requires acknowledgment. Click the button with the check mark to acknowledge the alarm.

See Rockwell Automation Library of Process Objects: Common Alarm Block (P\_Alarm) Reference Manual, publication [SYSLIB-RM002](#), for more information.

## Simulation

Simulation in P\_D4SD de-energizes the normal outputs and simulates the feedback of a working device.

You must set the Inp\_Sim parameter in the controller to '1' to enable simulation.

The Simulation icon  is displayed at the bottom left of the Operator faceplate indicating the device is in simulation.

While in simulation, you can set the delay (in seconds) for echoing back that the device has reached a state (Cfg\_SimFdbkT).

When you have finished in simulation, set the Inp\_Sim parameter in the controller to '0' to return to normal operation.

## Execution

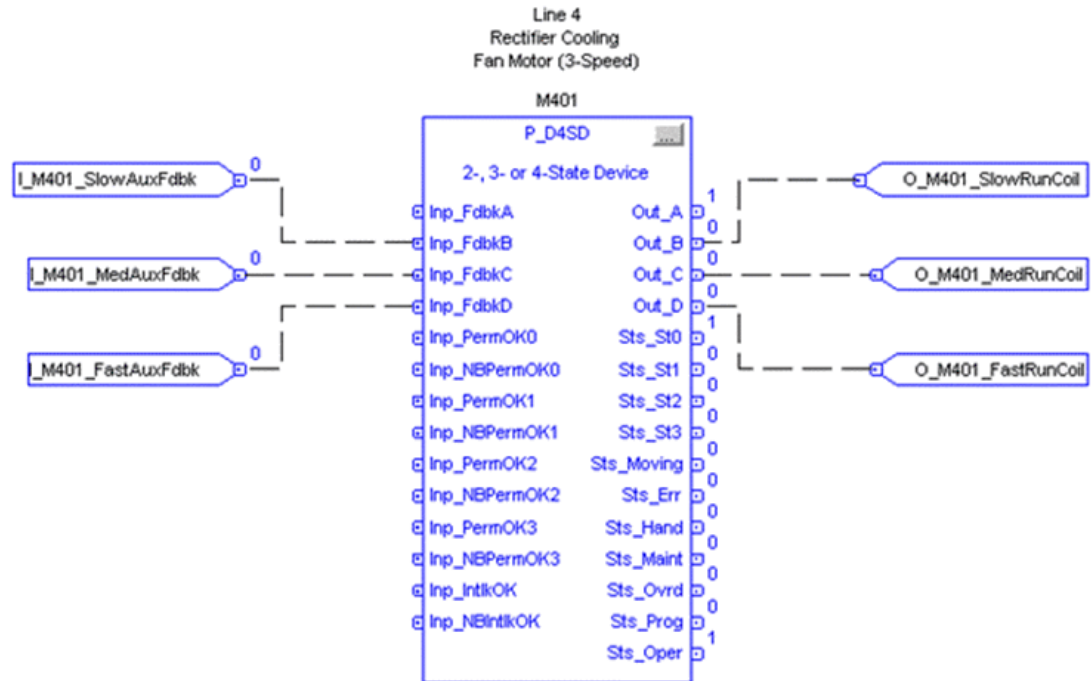
The following table explains the handling of instruction execution conditions.

Condition	Description
EnableIn False (false rung)	Handled the same as if the device were Disabled by Command. The device outputs are de-energized and the device is shown as Disabled on the HMI. The mode is shown as 'NO MODE'. All alarms are cleared.
Powerup (prescan, first scan)	On Prescan, any Commands received before First Scan are discarded. The device is de-energized. On first scan, the device is treated as if it were returning from Hand mode: the instruction state is set based on the position feedback received from the device.  Embedded P_Mode and P_Alarm instructions are handled in accordance with their standard powerup procedures. Refer to the P_Mode and P-Alarm reference manuals for details.
Postscan	No SFC Postscan logic is provided.

See the Logix5000 Controllers Add-On Instructions Programming Manual, publication [1756-PM010](#), for more information.

## Programming Example

This example uses the P\_D4SD Add-On Instruction to control a cooling fan that has three fixed speeds ('low', 'medium', 'high') and an 'off' state. This is considered a 4-state device. In this example, three digital outputs are used to set the speed setting (when all three are off, the fan is commanded off) and three digital inputs provide feedback of the actual fan state (when all three are off, the fan is off).



In this example, the four cooling fan states are being mapped to the device as follows:

- State 0 = Off
- State 1 = Low
- State 2 = Medium
- State 3 = High

Set the Cfg\_NumStates parameter to 4 to indicate this is a four-state device. The input parameters for states 1...3 (Inp\_FdbkB, Inp\_FdbkC, Inp\_FdbkD) are connected to the digital inputs, representing the status of the fan. The output parameters for states 1...3 (Out\_B, Out\_C, Out\_D) are connected to the digital outputs that command the fan to the desired state.

Based on the wiring of the I/O, we can now configure the P\_D4SD instruction how we want to process the outputs to get to the desired state. We can do this via the following table.

**Table 12 - P-D4SD Example Outputs**

	Output A	Output B	Output C	Output D
State 0	1	0	0	0
State 1	0	1	0	0
State 2	0	0	1	0
State 3	0	0	0	1

1 = command output On, 0 = command output Off.

We are setting Output A so it can be used for display purposes even though Output A is not used by the cooling fan device. The parameter `Cfg_OutSt[x]Write` determines which outputs get written for each state. The parameter `Cfg_OutSt[x]State` determines the state that gets written. These parameters are single integers where bit 0 represents output A and bit 3 represents output D.

These parameters are displayed in binary format as indicated by the prefix 2#. By using [Table 12](#), we can set the settings as follows:

```

Cfg_OutSt0Write:    2#0000_1111
Cfg_OutSt0State:   2#0000_0001
Cfg_OutSt1Write:    2#0000_1111
Cfg_OutSt1State:   2#0000_0010
Cfg_OutSt2Write:    2#0000_1111
Cfg_OutSt2State:   2#0000_0100
Cfg_OutSt3Write:    2#0000_1111
Cfg_OutSt3State:   2#0000_1000

```

We can now repeat this same effort to configure how the P\_D4SD instruction determines actual state based on the field inputs via the following table.

**Table 13 - P\_D4SD Example Inputs**

	Input A	Input B	Input C	Input D
State 0	x	0	0	0
State 1	x	1	0	0
State 2	x	0	1	0
State 3	x	0	0	1

x = status not checked, 1 = status checked on, 0 = status checked off



The parameter `Cfg_FdbkSt[x]Check` determines which feedback inputs to check for each state. The parameter `Cfg_FdbkSt[x]State` determines how the state is interpreted from the input values.

By using [Table 13](#), we can set the settings as follows:

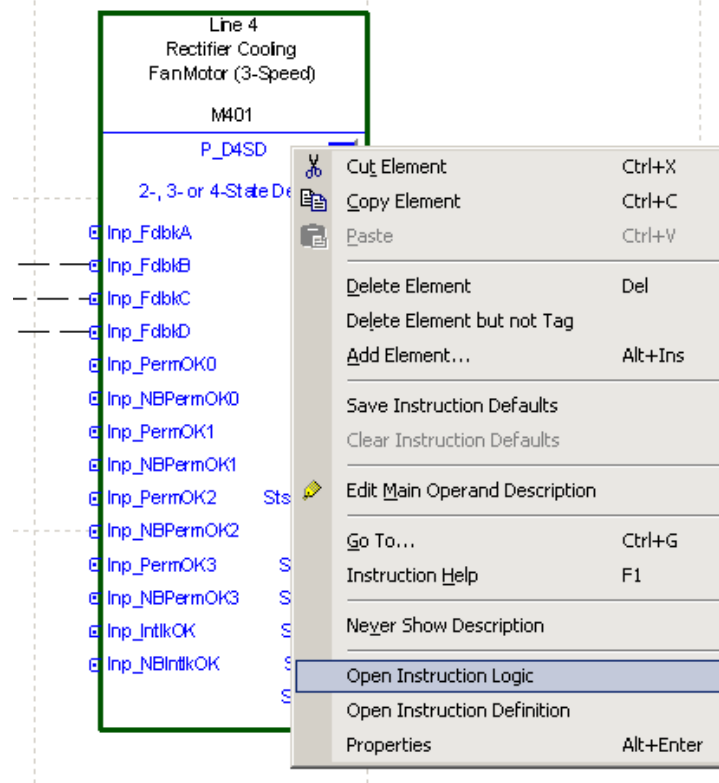
```
Cfg_FdbkSt0Check: 2#0000_1110
Cfg_FdbkSt0State: 2#0000_0000
Cfg_FdbkSt1Check: 2#0000_1110
Cfg_FdbkSt1State: 2#0000_0010
Cfg_FdbkSt2Check: 2#0000_1110
Cfg_FdbkSt2State: 2#0000_0100
Cfg_FdbkSt3Check: 2#0000_1110
Cfg_FdbkSt3State: 2#0000_1000
```

As this is a cooling fan, if there is a device mismatch or fault, we still want the logic to command to the desired state. Therefore, `Cfg_ShedOnFail` and `Cfg_ShedOnDeviceFault` are both set to 0.

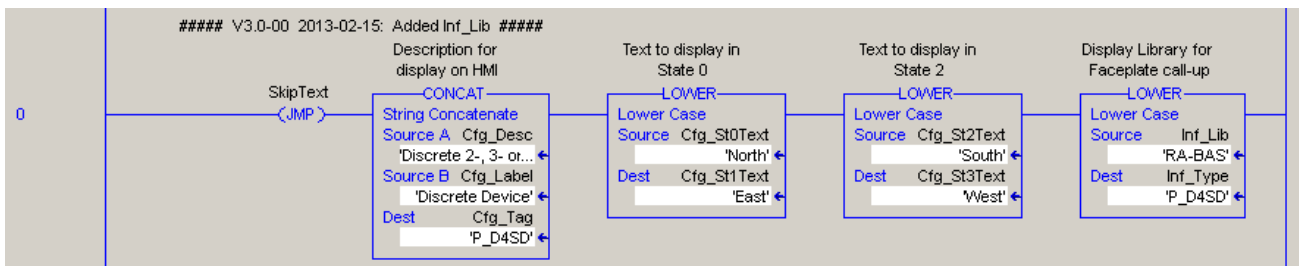
Lastly, configure the following local configuration tags to drive the text on the operations faceplate. In this example, the cooling fan P&ID tag is M401. In this example, they are set as follows:

```
Cfg_Tag: 'M401'
Cfg_Label: 'Line 4 Rectifier Fan'
Cfg_Desc: 'Line 4 Rectifier Cooling Fan'
Cfg_St0Text: 'Stopped'
Cfg_St1Text: 'Slow'
Cfg_St2Text: 'Medium'
Cfg_St3Text: 'Fast'
```

Local tags can be configured through the HMI faceplates or in Logix Designer application by opening the Instruction Logic of the Add-On Instruction instance and then selecting the string on the displayed rung.



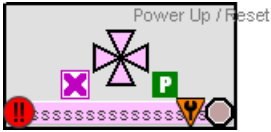
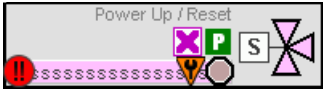

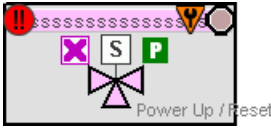
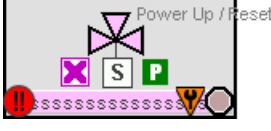
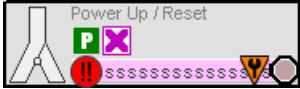

All strings in local tags are shown on the first rung of the Add-On Instruction's 'Logic' routine for your convenience.



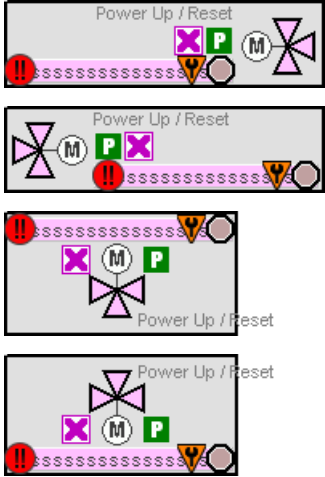
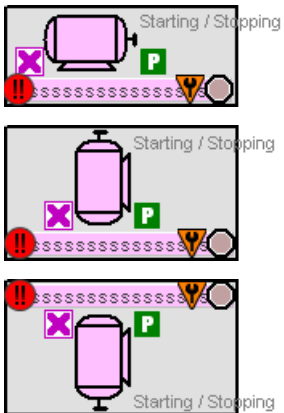
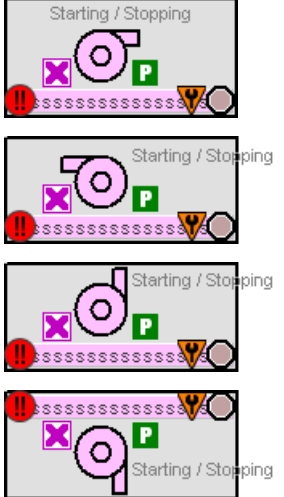
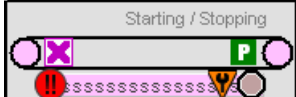
## Display Elements

A display element (global object) is created once and can be referenced multiple times on multiple displays in an application. When changes are made to the original (base) object, the instantiated copies (reference objects) are automatically updated. Use of global objects, in conjunction with tag structures in the ControlLogix system, aid consistency and save engineering time.


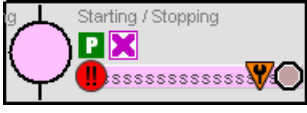
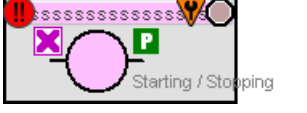




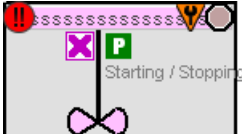



**Table 14 - P\_D4SD Display Elements Description**

Display Element Name	Display Element	Description
GO_P_D4SD_4Way		<p>Three/Four-Way Valve.</p> <p>The Three/Four-way Valve parameters define the inlet and output ports of the valve:</p> <ul style="list-style-type: none"> <li>No. 110 - Top port open state</li> <li>No. 111 - Right port open state</li> <li>No. 112 - Bottom port open state</li> <li>No. 113 - Left port open state</li> </ul> <ul style="list-style-type: none"> <li>0 = Inlet (always shown as open)</li> <li>1 = Open when Val_Sts = 1 (state 0)</li> <li>2 = Open when Val_Sts = 2 (state 1)</li> <li>3 = Open when Val_Sts = 3 (state 2)</li> <li>4 = Open when Val_Sts = 4 (state 3)</li> </ul>
GO_P_D4SD_3Way_SORt		<p>Two Way Solenoid-operated Diverter Valve in different positions: right, left, bottom, and top.</p> <p>Parameters define the inlet and output ports of the Two-way Solenoid-operated Diverter Valve.</p>
GO_P_D4SD_3Way_SOLt		
GO_P_D4SD_3Way_SOBtm		
GO_P_D4SD_3Way_SOTop		
GO_P_D4SD_Diverter		<p>Two Way Diverter Valve in open top-left and open top-right positions.</p> <p>The Two-way Diverter Valve parameters define the state of the valve:</p> <ul style="list-style-type: none"> <li>State 0: Open top-left</li> <li>State 1: Open top-right</li> <li>State 2: N/A</li> <li>State 3: N/A</li> </ul>
GO_P_D4SD_Diverter1		

**Table 14 - P\_D4SD Display Elements Description**

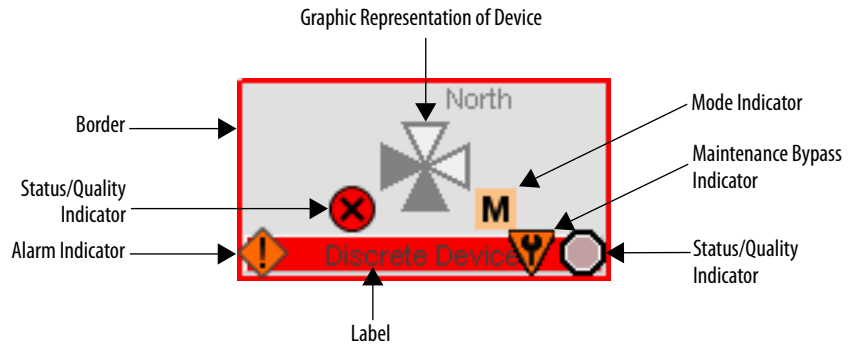
Display Element Name	Display Element	Description
<p>GO_P_D4SD_3WayMO_Rt</p> <p>GO_P_D4SD_3WayMO_Lt</p> <p>GO_P_D4SD_3WayMO_Btm</p> <p>GO_P_D4SD_3WayMO_Top</p>		<p>Two-Way Motor-operated Diverter Valve in different positions: right, left, bottom, and top. Parameters define the inlet and output ports of the Two-way Motor-operated Diverter Valve.</p>
<p>GO_P_D4SD_R</p> <p>GO_P_D4SD_U</p> <p>GO_P_D4SD_D</p>		<p>Motors in different positions: right, up, and down.</p>
<p>GO_P_D4SD_Blower_R</p> <p>GO_P_D4SD_Blower_L</p> <p>GO_P_D4SD_Blower_U</p> <p>GO_P_D4SD_Blower_D</p>		<p>Blowers in different positions: right, left, up, and down.</p>
<p>GO_P_D4SD_Conveyor-R</p>		<p>Conveyor</p>

**Table 14 - P\_D4SD Display Elements Description**

Display Element Name	Display Element	Description
GO_P_D4SD_Inline_U		Inline Motors in different positions: up, left, down, and right.
GO_P_D4SD_Inline_L		
GO_P_D4SD_Inline_D		
GO_P_D4SD_Inline_R		
GO_P_D4SD_Pump_R		Pumps in different positions: right, left, and up.
GO_P_D4SD_Pump_L		
GO_P_D4SD_Pump_U		
GO_P_D4SD_Agitator_D		Agitator in down position.
GO_P_D4SD_Mixer_U		Mixer in up position.
GO_P_D4SD_RPump_U		Rotary Gear Pump in up position.
GO_P_D4SD_Fan_D		Fan in down position.






Common attributes of the P\_D4SD global objects include the following:

- A graphic representation of the device
- Status/Quality indicator
- Maintenance Bypass indicator
- Mode indicator
- Label
- Color changing alarm border that blinks on unacknowledged alarm
- Alarm indicator that changes color with the severity of an alarm



## Status/Quality Indicators

One of these symbols appears on the graphic symbol when the described condition is true.

Graphic Symbol	Description
	Invalid configuration.
	Data quality bad/failure.
	Data Quality degraded: uncertain, test, simulation, substitution, or out of specification.
	The input or device has been disabled.
	Device not ready to operate.

### TIP

When the Invalid Configuration Indicator appears, you can find what configuration setting is invalid by following the indicators. Click the graphic symbol to open the faceplate. The Invalid Configuration indicator appears next to the appropriate tab at the top of the faceplate to guide you in finding the configuration error. Once you navigate to the tab, the misconfigured item is flagged with this indicator or appear in a magenta box.

For the Discrete 4-State Device Instruction, the Invalid Configuration indicator appears under the following conditions:

- The position failure check time or any output's pulse time is set to a value less than zero or greater than 2,147,483 seconds.
- The simulated motion time is set to a value less than zero or greater than 2,147,483 seconds.
- An Alarm Minimum On Time is set to a value less than zero or greater than 2,147,483 seconds.
- Alarm Severity is set to a value less than 1 or greater than 1000.




**TIP** When the Not Ready indicator appears, you can find what condition is preventing operation by following the indicators. Click the graphic symbol to open the faceplate. The Not Ready indicator appears next to the appropriate tab at the top of the faceplate to guide you in finding the condition. When you navigate to the tab, the condition preventing operation is flagged.






For the Discrete 4-State Device Instruction, the Device Not Ready indicator appears under the following conditions:

- Device has been disabled by Maintenance.
- There is a configuration error.
- Interlock or Permissive is not OK.
- Operator State 0 priority command requires reset.
- Device Failure and shed requires reset.
- I/O Fault and shed requires reset.
- External equipment fault and Fault or Shed requires reset.
- Device logic is disabled or there is no mode.

## Mode Indicators

One of these symbols appears on the right side of the graphic symbol to indicate the mode of the object instruction.

Graphic Symbol	Description
Transparent	Operator mode (if the default mode is Operator and the current mode is Operator, the mode indicator is transparent).
	Operator mode (if the default mode is Program).
	Operator mode locked.
Transparent	Program mode (if the default mode is Program and the current mode is Program, the mode indicator is transparent).
	Program mode (if the default mode is Operator).







Graphic Symbol	Description
	Program mode locked.
	Override mode
	Maintenance mode.
	Hand mode
	No mode.

**TIP** The images provided for the Operator and Program default modes are transparent; therefore, no mode indicators are visible if the device is in its default mode. This behavior can be changed by replacing the image files for these mode indicators with images that are not transparent.

See Rockwell Automation Library of Process Objects: Common Mode Block (P\_Mode) Reference Manual, publication [SYSLIB-RM005](#), for more information.

## Alarm Indicators

One of these symbols appears on the left side of the label to indicate the described alarm condition and the alarm border and label background change color. The alarm border and label background blink if acknowledgement of an alarm condition is required. Once the alarm is acknowledged, the alarm border and label background remain the color that corresponds to the severity of the alarm.

Symbol	Border and Label Background	Description
	No change in color	Alarm Inhibit: an alarm is suppressed by the Program, disabled by Maintenance, or shelved by the Operator.
	White	Return to normal (no alarm condition), but a previous alarm has not been acknowledged.
	Blue	Low severity alarm.
	Yellow	Medium severity alarm.
	Red	High severity alarm.
	Magenta	Urgent severity alarm.
No symbol	No change in color	No alarm or alarm inhibit condition, and all alarms are acknowledged.



See Rockwell Automation Library of Process Objects: Common Alarm Block (P\_Alarm) Reference Manual, publication [SYSLIB-RM002](#), for more information.

## Maintenance Bypass Indicator

This symbol appears to the right of the label to indicate that a maintenance bypass has been activated.

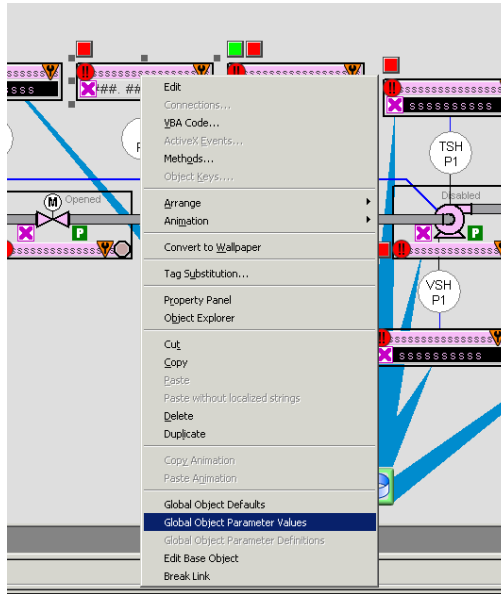
**TIP** When the Maintenance Bypass Indicator appears, you can find what condition was bypassed by following the indicators. Click the graphic symbol to open the faceplate. The Maintenance Bypass Indicator appears next to the appropriate tab at the top of the faceplate to guide you in finding the bypass. Once you navigate to the tab, the bypassed item is flagged with this indicator.

For the Discrete 4-State Device Instruction, the Maintenance Bypass Indicator appears when Maintenance has bypassed the bypassable interlocks and permissives.

## Using Display Elements

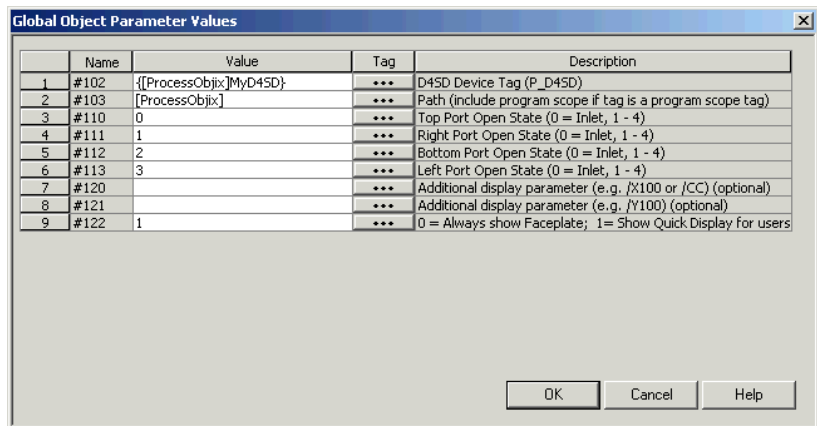
The global objects for this instruction can be found in the global object file (RA-BAS) P\_D4SD Graphics Library.ggfx. Complete the following to use a global object.

1. Copy it from the global object file and paste it in the display file.



2. In the display file, right-click the global object file and choose Global Object Parameter Values.

The Global Object Parameter Values dialog box appears.



The global object parameters are as follows.

Parameter	Required	Description
#102	Y	Object tag to point to the name of the associated object Add-On Instruction in the controller.
#103	Y	Path used for display navigation features to other objects. Include program scope if tag is a program scope tag.
#110	Y	Top port Open state (0 = Inlet, 1-4)
#111	Y	Right port Open state (0 = Inlet, 1-4)
#112	Y	Bottom port Open state (0 = Inlet, 1-4)
#113	Y	Left port Open state (0 = Inlet, 1-4)
#120	N	Additional parameter to pass to the display command to open the faceplate. Typically used to define position for the faceplate.
#121	N	Additional parameter to pass to the display command to open the faceplate. If defining X and Y coordinate, separate parameters so that X is defined by #120 and Y is defined by #121. This lets the same parameters be used in subsequent display commands originating from the faceplate.
#122	Y	These are the options for the global object display: 0 = Always show faceplate 1 = Show Quick Display for users without Maintenance access (Code C) 2 = Always show Quick Display

**IMPORTANT** The preceding table is for the Three/Four Way Valve. Other valves that are used have similar parameters but different configurations.

3. Type the tag or value in the Value column as specified in the Description column.

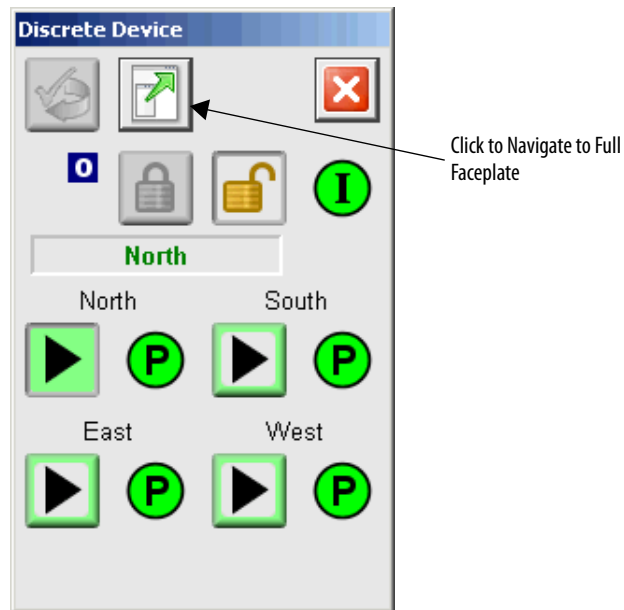
**TIP** You can click the ellipsis (...) to browse and select a tag.

Values for items marked '(optional)' can be left blank.

4. Click OK.

## Quick Display

The Quick Display screen provides a means for operators to perform simple interactions with the P\_D4SD instruction instance. From the Quick Display, you can navigate to the faceplate for full access for operation, maintenance, and configuration.

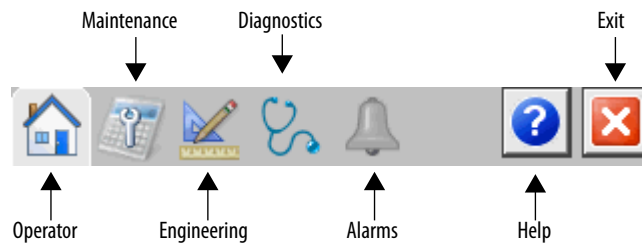


## Faceplate

The P\_D4SD faceplate consists of five tabs and each tab consists of one or more pages. Each faceplate contains the value of local configuration tags Cfg\_Tag and Cfg\_Desc in the title bar.

### Tag - Description

The Operator tab is displayed when the faceplate is initially opened. Click the appropriate icon at the top of the faceplate to access a specific tab.



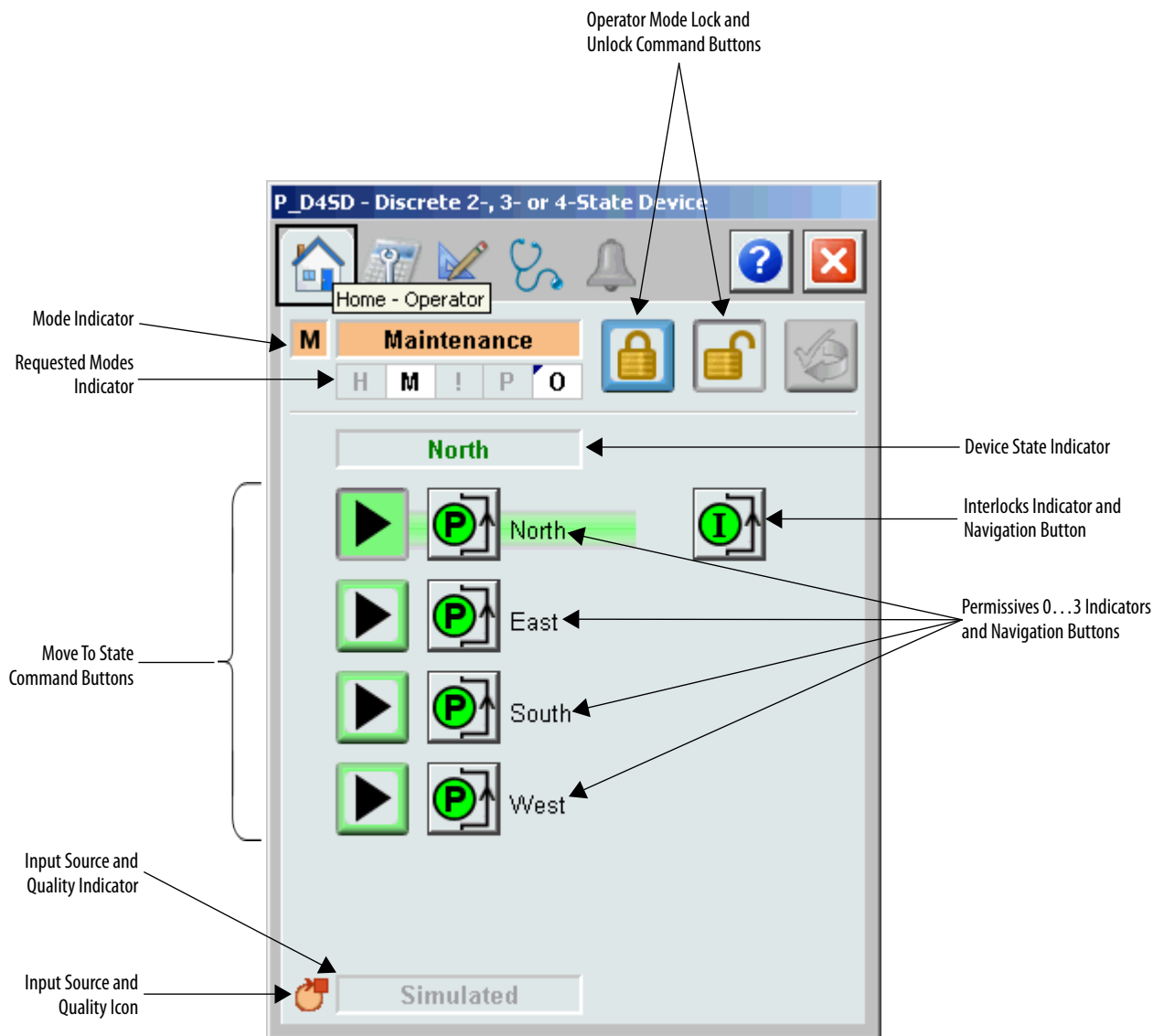
The faceplate provides the means for operators, maintenance personnel, engineers, and others to interact with the P\_D4SD Instruction instance, including viewing its status and values and manipulating it through its commands and settings. When a given input is restricted via FactoryTalk View security, the required user security code letter is shown in the tables that follow.

## Operator Tab

The Faceplate initially opens to the Operator ('Home') tab. From here, an operator can monitor the device status and manually operate the device when it is in Operator mode.









The Operator tab shows the following information:

- Current Mode (Program, Operator, Override, Maintenance, or Hand)
- Requested Modes Indicator (appears only if the Operator or Program Mode has been superseded by another mode)
- Device states
- Permissive states
- Input Source and Quality indicator (See 'SrcQ' in the Output parameters table on [page 16](#) for details)



The following table shows the functions that are included on the Operator tab.

**Table 15 - Operator Tab Description**









Function	Action	Security
	Click to release Operator mode lock.	Manual Device Operation (Code B)
	Click to lock in Operator mode.	
	Click to request Program mode.	
	Click to request Operator mode.	
	Click to reset and acknowledge all alarms.	Acknowledge Alarms (Code F)
	Click to command the device to a state.	Normal Operation of Device (Code A)
	There are up to four Permissive status indicators/buttons. Click the button beside each state to view the faceplate for Permissives associated with that state. The Permissive button appears when Cfg_HasPerm0Obj, Cfg_HasPerm1Obj, Cfg_HasPerm2Obj, or Cfg_HasPerm3Obj is set.	None
	Click to open the interlock faceplate for the device. This button appears if Cfg_HasIntlkObj is set and opens the faceplate associated with the P_Intlk instruction configured in the global object instance.	

If the object is configured to have permissive and interlock objects (for example, Cfg\_HasIntlkObj is true), the permissive and interlock indication become buttons that open the faceplates of the source objects used as a permissive or interlock (often this is a P\_Intlk or P\_Perm object). If the object is not configured in this way, the permissive or interlock are indicators only.

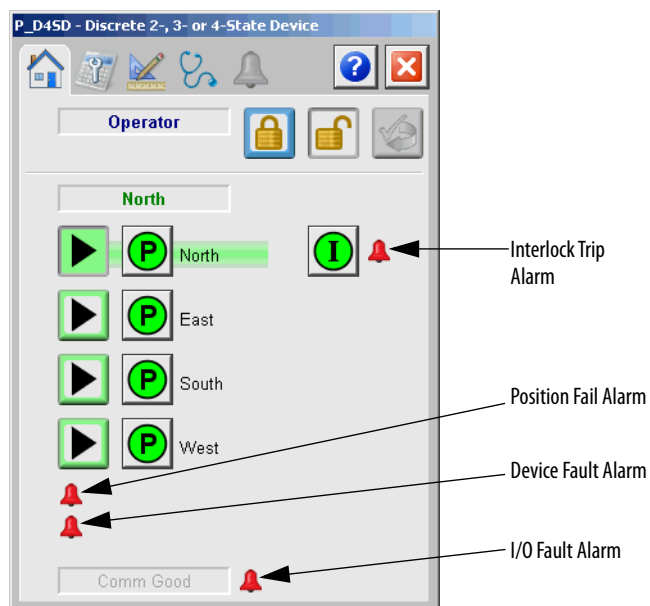
See these publications for more information:

- Rockwell Automation Library of Process Objects: Interlock with First Out and Bypass (P\_Intlk) Reference Manual, publication [SYSLIB-RM004](#)
- Rockwell Automation Library of Process Objects: Permissives with Bypass (P\_Perm) Reference Manual, publication [SYSLIB-RM007](#)

One of these symbols appears to indicate the described Interlock or Permissive condition.







Permissive Symbol	Interlock Symbol	Description
		One or more conditions not OK
		Non-bypassed conditions OK
		All conditions OK, bypass active
		All conditions OK

Alarm indicators appear on the Operator tab when the corresponding alarm occurs.



The following table shows the alarm status on the Operator tab.

**Table 16 - Operator Tab Alarm Status**

Graphic Symbol	Alarm Status
	In Alarm (Active Alarm)
	In Alarm and Acknowledged
	Out of Alarm but Not Acknowledged
	Alarm Suppressed (by Operator) (Alarm is logged but not displayed)
	Alarm Disabled (by Maintenance)
	Alarm Shelved (by Operator)



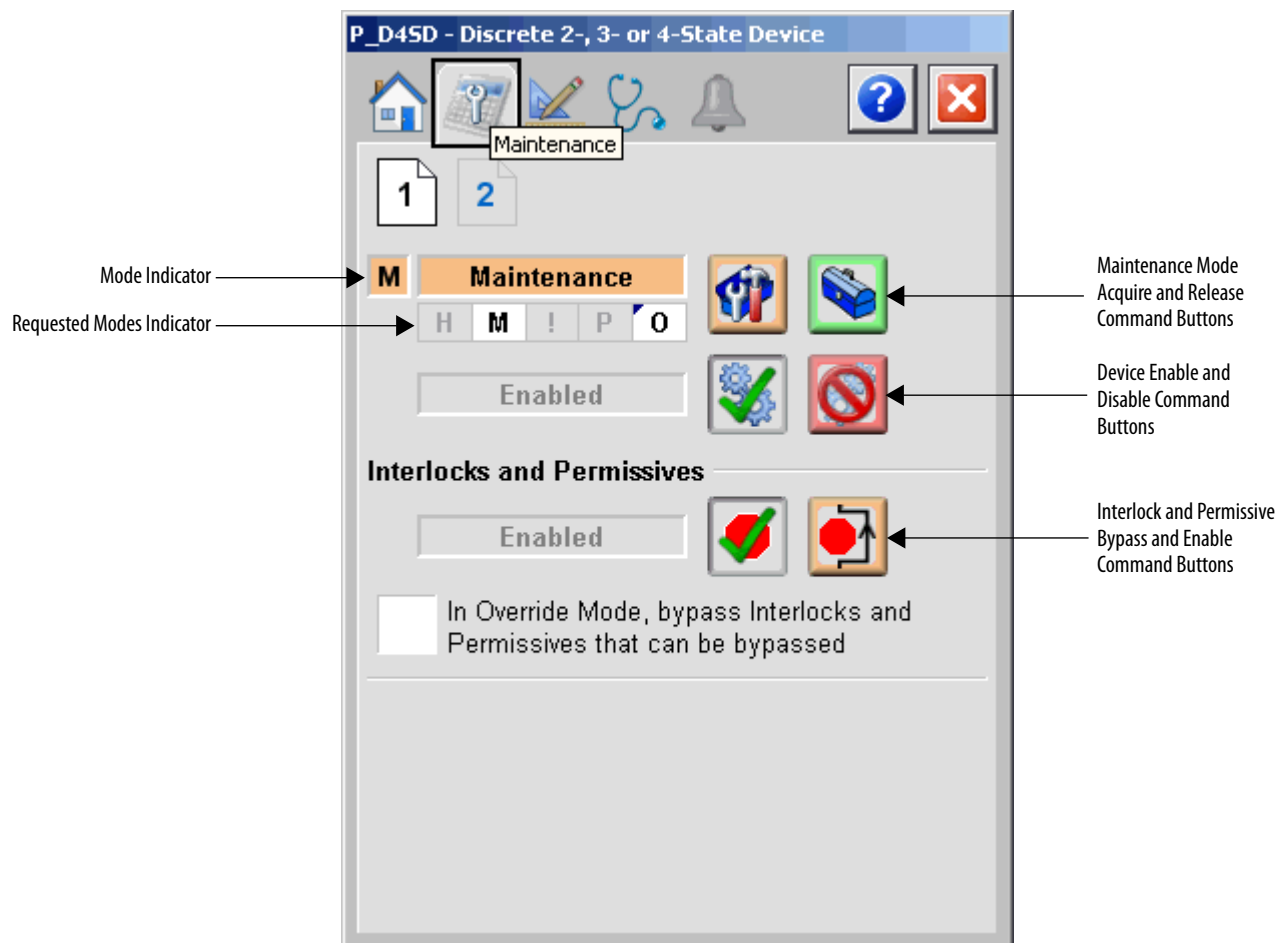
## Maintenance Tab

Maintenance personnel use the information and controls on the Maintenance tab to adjust device parameters, troubleshoot and temporarily work around device problems, and disable the device for routine maintenance.

### Maintenance Tab Page 1







Page 1 of the Maintenance tab shows the following information:

- Current mode (Program, Operator, Override, Maintenance, or Hand)
- Requested Modes Indicator - This display highlights all modes that have been requested. The leftmost highlighted mode is the active mode
- Shows whether the device is enabled or disabled
- Shows Permissive Bypassed/Enabled Indicator
- Shows whether Override mode bypasses the bypassable permissives



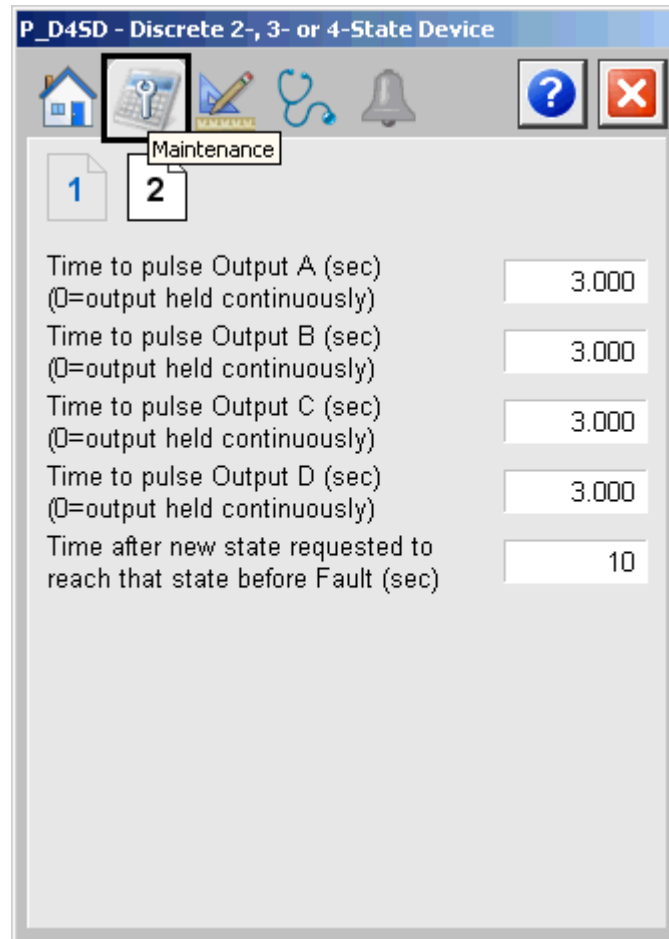
The following table shows the functions on page 1 of the Maintenance tab.

**Table 17 - Maintenance Tab Page One Description**

Function	Action	Security	Configuration Parameters
	Click to release device from Maintenance mode	Equipment Maintenance (Code C)	None
	Click to place device in Maintenance mode		
	Click to enable the device		
	Click to disable the device		
	Click to enable checking of all permissives and interlocks	Disable Alarms Bypass Permissives and Interlocks (Code H)	Cfg_OvrPermIntlk
	Click to bypass checking of bypassable permissives and interlocks		
In Override Mode, bypass Interlocks and Permissives that can be bypassed	Check to bypass the bypassable permissives and interlocks in Override mode		

## Maintenance Tab Page 2

Page 2 of the Maintenance tab shows data entry fields for several configuration parameters.



The following table shows the functions on page 2 of the Maintenance tab.

**Table 18 - Maintenance Tab Page 2 Description**

Function	Action	Security	Configuration Parameters
Time to pulse: Output A (sec) Output B (sec) Output C (sec) Output D (sec)	Type a value (0...2,147,483.647) to indicate the time (seconds) to energize outputs to the device to be sure they are latched in. (0 = output held continuously)	Configuration and Tuning Maintenance (Code D)	<ul style="list-style-type: none"> <li>• Cfg_OutAPulseT</li> <li>• Cfg_OutBPulseT</li> <li>• Cfg_OutCPulseT</li> <li>• Cfg_OutDPulseT</li> </ul>
Time after new state requested to reach that state before Fault (sec)	Type a value (0...2,147,483.647) to indicate the time (seconds) to allow the device to reach the commanded state before issuing a fault.		Cfg_FailT

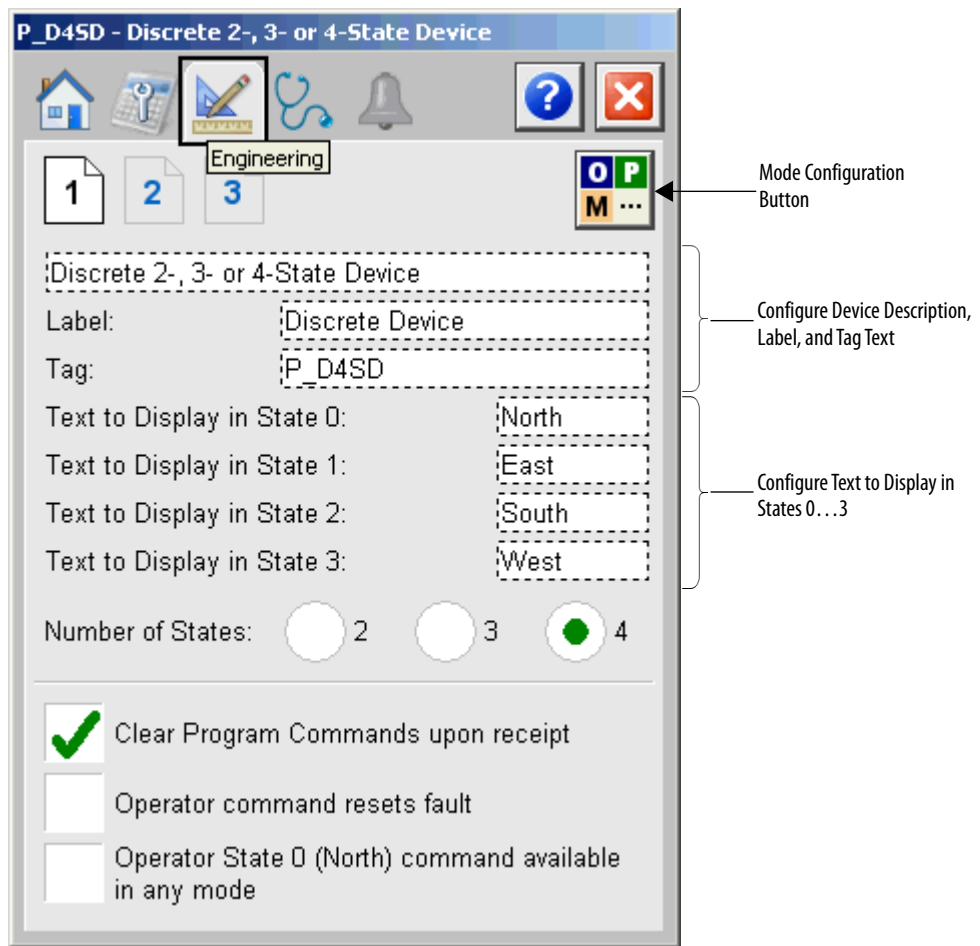
## Engineering Tab

The Engineering tab provides access to device configuration parameters and ranges, options for device and I/O setup, displayed text, and faceplate-to-faceplate navigation settings, and for initial system commissioning or later system changes.

The engineering tab is divided into three pages.


### Engineering Tab Page 1

Page 1 of the Engineering tab lets you configure the description, label, tag, and state names for the device.

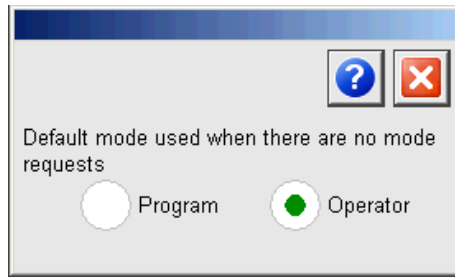


The following table lists the functions on the Engineering tab page 1.

**Table 19 - Engineering Tab Page 1 Description**

Function	Action	Security	Configuration Parameters
	Click to navigate to the Mode Configuration display box.	None	See Mode Configuration Message Display on <a href="#">page 46</a> .
Description	Type the device description to show on the Faceplate title bar.	Engineering Configuration (Code E)	Cfg_Desc
Label	Type the label to show on the Graphic Symbol.		Cfg_Label
Tag	Type the tag name to show on the Faceplate and Tooltip. <b>IMPORTANT:</b> Pausing the mouse over this field displays a tool tip with the configured Logix tag/path.		Cfg_Tag
Text to Display in: State 0: State 1: State 2: State 3:	Type text to describe the state.		<ul style="list-style-type: none"> <li>• Cfg_St0Text</li> <li>• Cfg_St1Text</li> <li>• Cfg_St2Text</li> <li>• Cfg_St3Text</li> </ul>
Number of States: 2 3 4	Click to select the number of states.		Cfg_NumStates
Clear Program Commands on Receipt	Check to set this parameter to one of the following: <ul style="list-style-type: none"> <li>• ON to use Edge-triggered Program Commands (default).</li> <li>• OFF to use Level-triggered Program Commands.</li> </ul>		Cfg_PCmdClear
Operator command resets fault	Check to reset a fault upon a new operator command.		Cfg_OCcmdResets
Operator State 0 command available in any mode	Check (= 1) to make Operator State 0 (OCmd_St0) available in any mode. Clear this checkbox (= 0) to make Operator State 0 (OCmd_St0) available only in Operator or Maintenance mode.		Cfg_OperSt0Prio

### Mode Configuration Display



This display lets you select the default mode for the object by selecting the appropriate mode.

---

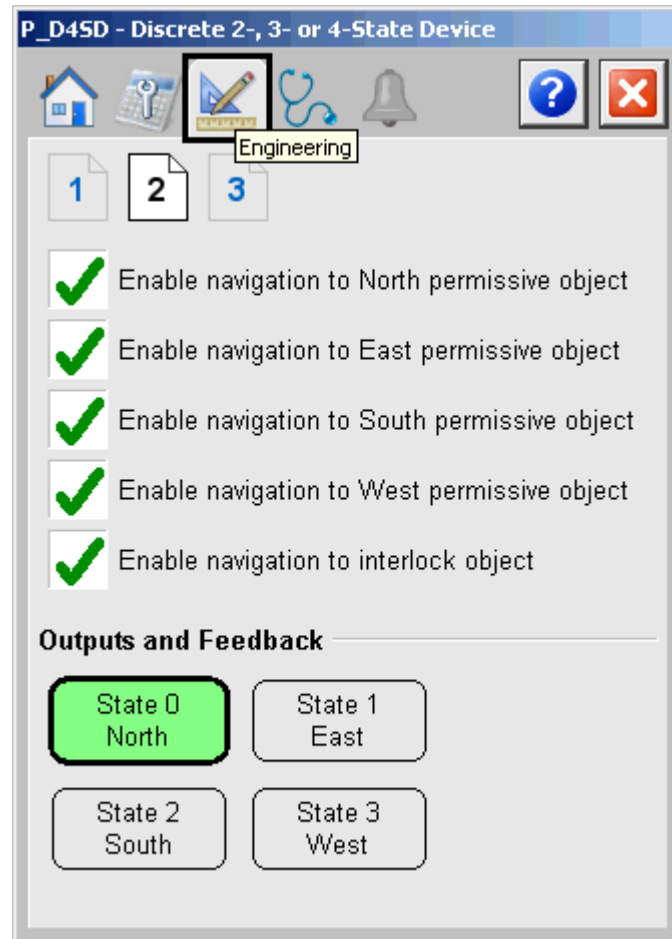
**IMPORTANT** If no mode is being requested, changing the default mode changes the mode of the instruction.

---

You must have FactoryTalk View security code E to select the default mode on this display.

## Engineering Tab Page 2

Page 2 of the Engineering tab lets you enable navigation to the Permissive or Interlock objects and to set the output and feedback for the states.



The following table shows the functions on the Engineering tab page 2.

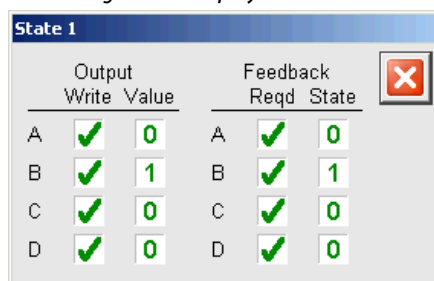
**Table 20 - Engineering Tab Page 2 Description**

Function	Action	Security	Configuration Parameters
Enable navigation to North/South/East/West Permissive objects	<p>Check if the corresponding north, south, east, or west Permissive object is used with this device This changes the Permissive Indicator to a button that accesses the Permissive faceplate.</p> <p><b>IMPORTANT:</b> The name of the Permissives object in the controller must be this object's name with the suffix '_Perm#', where '#' is the permissive number (0...3) For example, if your P_D4SD object has the name 'D4SD123', then its Permissives object must be named 'D4SD123_Perm0'.</p>	Engineering Configuration (Code E)	<ul style="list-style-type: none"> <li>• Cfg_HasPerm0Obj</li> <li>• Cfg_HasPerm1Obj</li> <li>• Cfg_HasPerm2Obj</li> <li>• Cfg_HasPerm3Obj</li> </ul>

**Table 20 - Engineering Tab Page 2 Description**

Function	Action	Security	Configuration Parameters
Enable navigation to interlock object	Check if a P_Intlk object is used with this device. <b>IMPORTANT:</b> The name of the Permissive object in the controller must be this object's name with the suffix '_Intlk'. For example, if your P_DOut object has the name 'DOut123', then its Permissive object must be named 'DOut123_Intlk'.	Engineering Configuration (Code E)	Cfg_HasIntlkObj
Outputs and Feedback	Click a state to open the P_D4SD State Configuration display for that state.	None	See State Configuration display on <a href="#">page 48</a> .

*State Configuration Display*

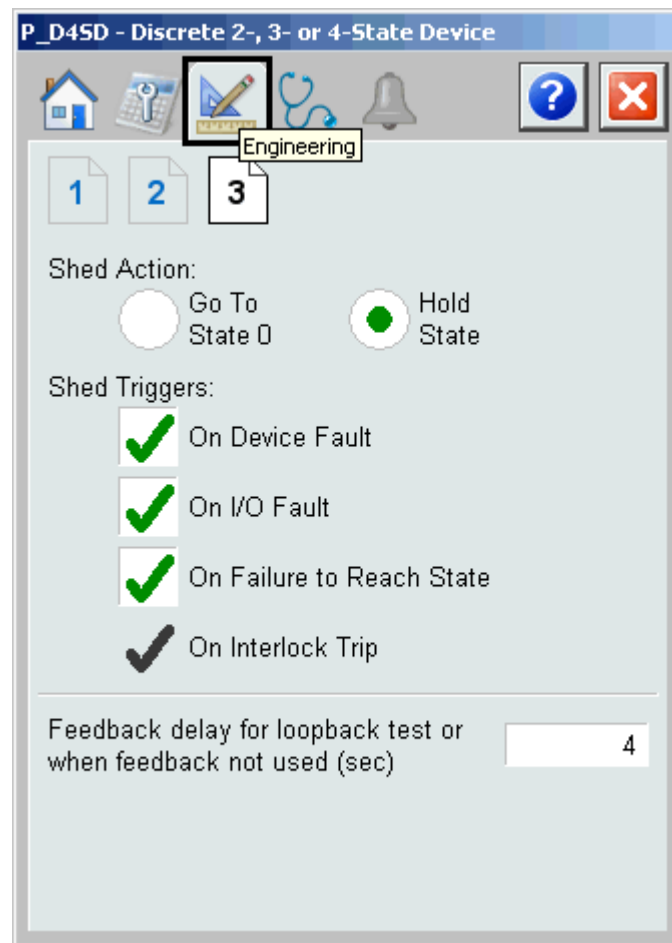


This display directs how the P\_D4SD instruction commands the device state via outputs and determines the actual device state via feedback inputs. The first two columns for output set parameters, Cfg\_OutSt[x]Write, and Cfg\_OutSt[x]Value, determine how outputs are written to command to a state. The second two columns for feedback set parameters, Cfg\_FdbkSt[x]Check, and Cfg\_FdbkSt[x]State, determine how the state is interpreted from the input values.

Changing the parameters requires engineering access (security code E).



## Engineering Tab Page 3



The following table shows the functions on page 3 of the Engineering tab.

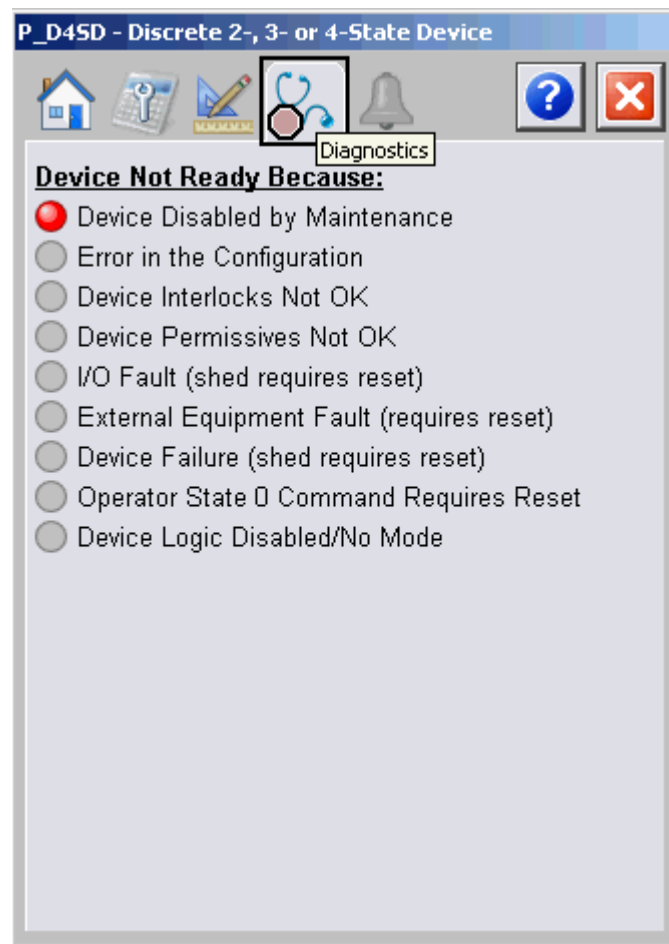
**Table 21 - Engineering Tab Page 3 Description**

Function	Action	Security	Configuration Parameters
Shed Action: Go to State 0	Click to determine whether you hold position or go to state 0 upon a shed condition.	Engineering Configuration (Code E)	Cfg_St0onShed
Hold State			
Shed Triggers: On Device Fault	Check to shed if a Device Fault is detected.		Cfg_ShedOnDeviceFault
Shed Triggers: On I/O Fault	Check to shed if an I/O Fault is detected.		Cfg_ShedOnIOFault
Shed Triggers: On Failure to Reach State	The device always sheds an Interlock Trip. This item cannot be unchecked. It is displayed as a reminder that the Interlock Trip function always triggers a shed.		Cfg_ShedOnFail
Feedback delay for loopback test or when feedback not used (seconds)	Type a value (seconds) to indicate the delay to echo back reaching state when in simulation.		Cfg_SimFdbkT

## Diagnostics Tab

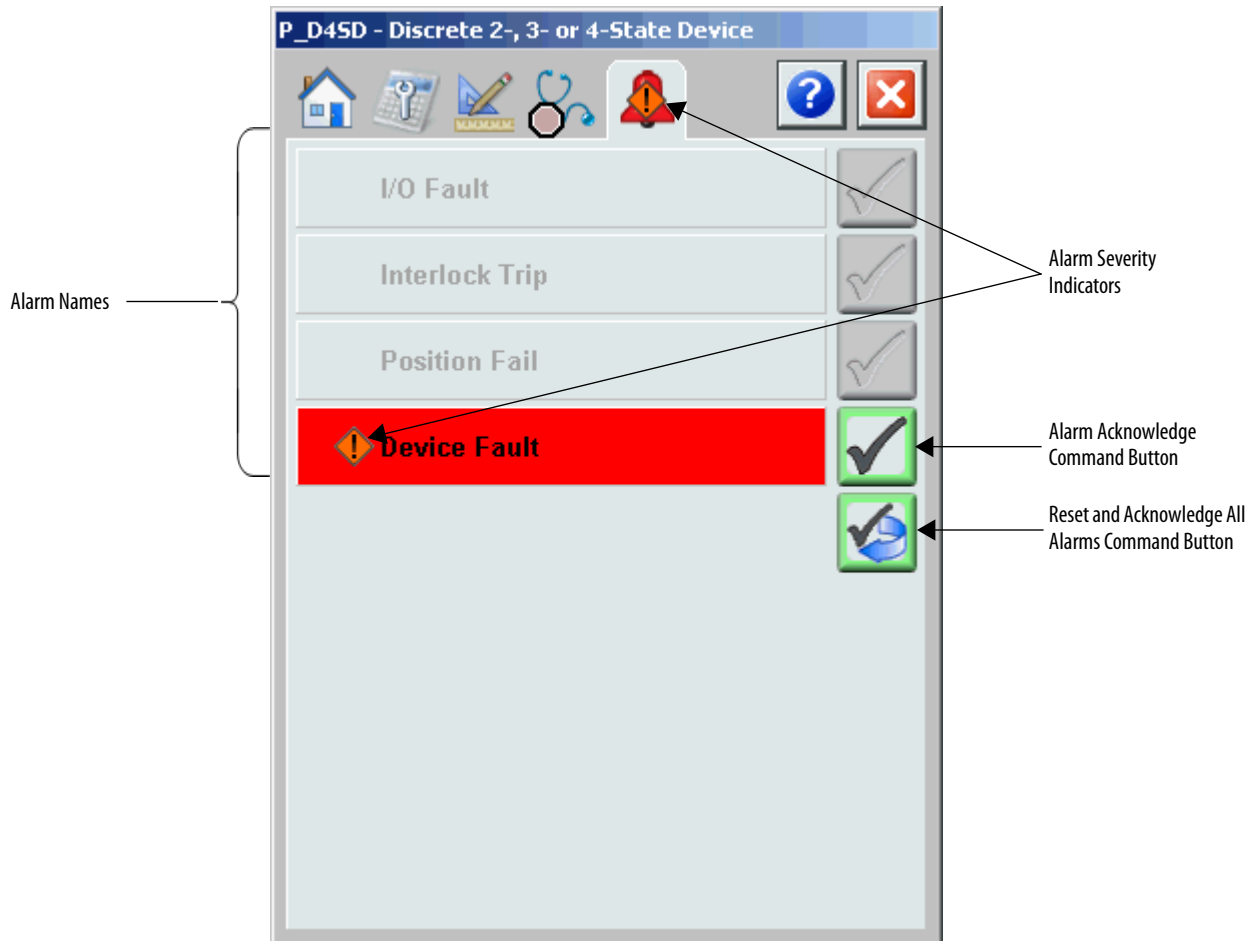
The Diagnostic tab provides indications helpful in diagnosing or preventing device problems, which can include specific reasons a device is 'Not Ready', device warnings and faults, warning and fault history, and predictive/preventive maintenance data.

The Diagnostics tab displays possible reasons the device is not ready.



## Alarms Tab

The Alarms tab displays each configured alarm for the P\_D4SD instruction. The icon on the tab for the alarms page changes color based on the current active alarms. A blinking alarm icon indicates that one or more alarms must be acknowledged or the device must be reset.



Click an alarm name to open the P\_Alarm faceplate for that alarm. From the P\_Alarm faceplate, you can configure and perform additional operations on the alarm.



If an alarm is active, the panel behind the alarm changes color to match the severity of the alarm. The color of the bell icon at the top of the faceplate shows the severity of the highest active alarm, and the icon blinks if any alarm is unacknowledged or requires reset.

**Table 22 - Alarm Severity Colors**

Color	Definition
Magenta	Urgent
Red	High
Yellow	Medium
Blue	Low
White (bell icon)	Alarm has cleared but is unacknowledged
Background (Light Gray)	No alarm

The following table shows the functions on the Alarms tab.

**Table 23 - Alarms Tab Description**

Function	Action	Security
Alarm Name	Click an alarm name to open the associated P_Alarm faceplate.	None
	Click to acknowledge the alarm.	Acknowledge Alarms (Code F)
	Click to reset and acknowledge all alarms.	

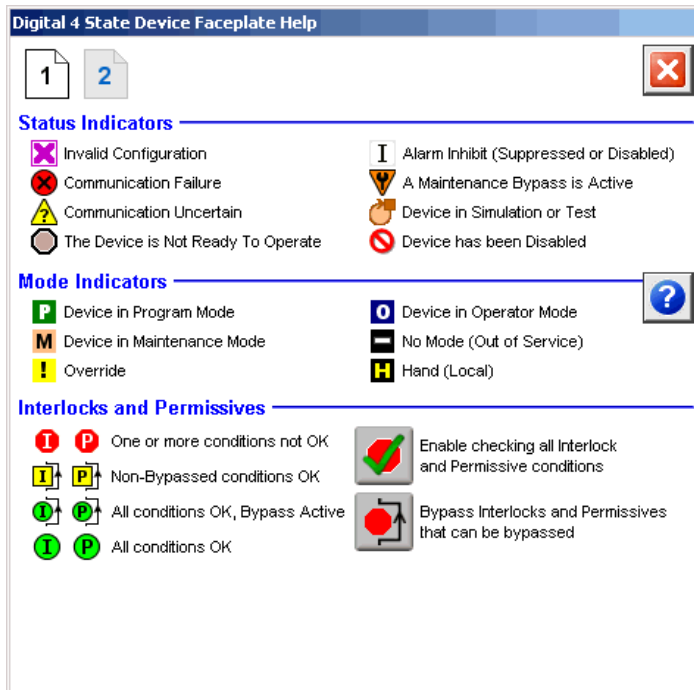
When the Reset and Acknowledge All Alarms button is enabled, the panel behind the alarm blinks, indicating the alarm requires acknowledgement or reset. The Alarm Acknowledge button is enabled if the alarm requires acknowledgment. Click the button with the check mark to acknowledge the alarm.

See Rockwell Automation Library of Process Objects: Common Alarm Block (P\_Alarm) Reference Manual, publication [SYSLIB-RM002](#), for more information.

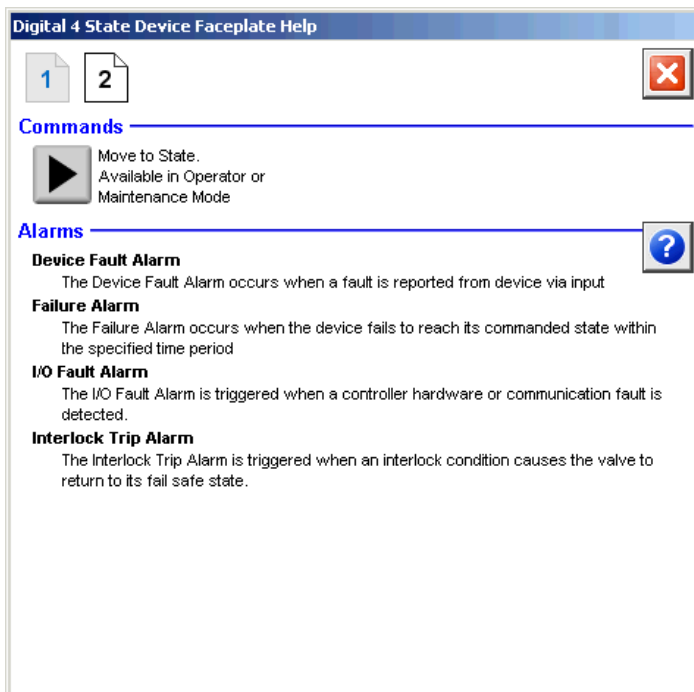
## Discrete 2-, 3-, 4-state Device Faceplate Help

The Faceplate Help is divided into two pages.

### Faceplate Help Page 1



### Faceplate Help Page 2



**Notes:**



## Rockwell Automation Support

Rockwell Automation provides technical information on the Web to assist you in using its products.

At <http://www.rockwellautomation.com/support> you can find technical and application notes, sample code, and links to software service packs. You can also visit our Support Center at <https://rockwellautomation.custhelp.com/> for software updates, support chats and forums, technical information, FAQs, and to sign up for product notification updates.

In addition, we offer multiple support programs for installation, configuration, and troubleshooting. For more information, contact your local distributor or Rockwell Automation representative, or visit <http://www.rockwellautomation.com/services/online-phone>.

## Installation Assistance

If you experience a problem within the first 24 hours of installation, review the information that is contained in this manual. You can contact Customer Support for initial help in getting your product up and running.

United States or Canada	1.440.646.3434
Outside United States or Canada	Use the <a href="#">Worldwide Locator</a> at <a href="http://www.rockwellautomation.com/rockwellautomation/support/overview.page">http://www.rockwellautomation.com/rockwellautomation/support/overview.page</a> , or contact your local Rockwell Automation representative.

## New Product Satisfaction Return

Rockwell Automation tests all of its products to help ensure that they are fully operational when shipped from the manufacturing facility. However, if your product is not functioning and needs to be returned, follow these procedures.

United States	Contact your distributor. You must provide a Customer Support case number (call the phone number above to obtain one) to your distributor to complete the return process.
Outside United States	Please contact your local Rockwell Automation representative for the return procedure.

## Documentation Feedback

Your comments will help us serve your documentation needs better. If you have any suggestions on how to improve this document, complete this form, publication [RA-DU002](#), available at <http://www.rockwellautomation.com/literature/>.

Rockwell Automation maintains current product environmental information on its website at <http://www.rockwellautomation.com/rockwellautomation/about-us/sustainability-ethics/product-environmental-compliance.page>.

Rockwell Otomasyon Ticaret A.Ş., Kar Plaza İş Merkezi E Blok Kat:6 34752 İçerenköy, İstanbul, Tel: +90 (216) 5698400

**[www.rockwellautomation.com](http://www.rockwellautomation.com)**

### Power, Control and Information Solutions Headquarters

Americas: Rockwell Automation, 1201 South Second Street, Milwaukee, WI 53204-2496 USA, Tel: (1) 414.382.2000, Fax: (1) 414.382.4444  
Europe/Middle East/Africa: Rockwell Automation NV, Pegasus Park, De Kleetlaan 12a, 1831 Diegem, Belgium, Tel: (32) 2 663 0600, Fax: (32) 2 663 0640  
Asia Pacific: Rockwell Automation, Level 14, Core F, Cyberport 3, 100 Cyberport Road, Hong Kong, Tel: (852) 2887 4788, Fax: (852) 2508 1846

Publication SYSLIB-RM028E-EN-P - February 2017

Supersedes Publication SYSLIB-RM028D-EN-P - January 2016

Copyright © 2017 Rockwell Automation, Inc. All rights reserved. Printed in the U.S.A.