

# Rockwell Automation Library of Process Objects: Interlocks with First Out and Bypass (P\_Intlk)

Version 3.5

**IMPORTANT**

This manual applies to the Rockwell Automation Library of Process Objects version 3.5 or earlier.  
For Rockwell Automation Library of Process Objects version 5.0, see

- [PROCES-RM200](#)

For Rockwell Automation Library of Process Objects version 4.0 or later, use the following manuals:

- [PROCES-RM013](#) contains logic instructions
- [PROCES-RM014](#) contains display elements



## Important User Information

Read this document and the documents listed in the additional resources section about installation, configuration, and operation of this equipment before you install, configure, operate, or maintain this product. Users are required to familiarize themselves with installation and wiring instructions in addition to requirements of all applicable codes, laws, and standards.

Activities including installation, adjustments, putting into service, use, assembly, disassembly, and maintenance are required to be carried out by suitably trained personnel in accordance with applicable code of practice.

If this equipment is used in a manner not specified by the manufacturer, the protection provided by the equipment may be impaired.

In no event will Rockwell Automation, Inc. be responsible or liable for indirect or consequential damages resulting from the use or application of this equipment.

The examples and diagrams in this manual are included solely for illustrative purposes. Because of the many variables and requirements associated with any particular installation, Rockwell Automation, Inc. cannot assume responsibility or liability for actual use based on the examples and diagrams.

No patent liability is assumed by Rockwell Automation, Inc. with respect to use of information, circuits, equipment, or software described in this manual.

Reproduction of the contents of this manual, in whole or in part, without written permission of Rockwell Automation, Inc., is prohibited.

Throughout this manual, when necessary, we use notes to make you aware of safety considerations.



**WARNING:** Identifies information about practices or circumstances that can cause an explosion in a hazardous environment, which may lead to personal injury or death, property damage, or economic loss.



**ATTENTION:** Identifies information about practices or circumstances that can lead to personal injury or death, property damage, or economic loss. Attentions help you identify a hazard, avoid a hazard, and recognize the consequence.

---

### IMPORTANT

Identifies information that is critical for successful application and understanding of the product.

---

Labels may also be on or inside the equipment to provide specific precautions.



**SHOCK HAZARD:** Labels may be on or inside the equipment, for example, a drive or motor, to alert people that dangerous voltage may be present.



**BURN HAZARD:** Labels may be on or inside the equipment, for example, a drive or motor, to alert people that surfaces may reach dangerous temperatures.



**ARC FLASH HAZARD:** Labels may be on or inside the equipment, for example, a motor control center, to alert people to potential Arc Flash. Arc Flash will cause severe injury or death. Wear proper Personal Protective Equipment (PPE). Follow ALL Regulatory requirements for safe work practices and for Personal Protective Equipment (PPE).

---

---

<b>Preface</b>	Software Compatibility and Content Revisions . . . . .	5
	Additional Resources . . . . .	5
<b>Interlocks with First Out and Bypass (P_Intlk)</b>	Guidelines . . . . .	7
	Functional Description . . . . .	8
	Required Files . . . . .	10
	Controller File . . . . .	10
	Visualization Files . . . . .	10
	Controller Code . . . . .	12
	Interlocks Input Structure . . . . .	12
	Interlocks Output Structure . . . . .	13
	Interlocks Local Configuration Tags . . . . .	14
	Operations . . . . .	14
	Modes . . . . .	14
	Alarms . . . . .	14
	Simulation . . . . .	15
	Execution . . . . .	15
	Programming Example . . . . .	15
	Display Elements . . . . .	19
	Status and Bypass Indicators . . . . .	20
	Using Display Elements . . . . .	21
	Faceplate . . . . .	23
	Operator Tab . . . . .	24
	Maintenance Tab . . . . .	27
	Engineering Tab . . . . .	28
	Interlock Faceplate Help . . . . .	32

**Notes:**

## Software Compatibility and Content Revisions

Table 1 - Summary of Changes

Topic	Page
Local Configuration Tags - Navigation Tag	14

For the latest compatible software information and to download the Rockwell Automation® Library of Process Objects, see the Product Compatibility and Download Center at <http://www.rockwellautomation.com/rockwellautomation/support/pcdc.page>.

For general library considerations, see Rockwell Automation Library of Process Objects, publication [PROCES-RM002](#).

## Additional Resources

These documents contain more information about related products from Rockwell Automation.

Resource	Description
PlantPAx® Distributed Control System Selection Guide, publication <a href="#">PROCES-SG001</a>	Provides information to assist with equipment procurement for your PlantPAx® system.
PlantPAx Distributed Control System Reference Manual, publication <a href="#">PROCES-RM001</a>	Provides characterized recommendations for implementing your PlantPAx system.
Rockwell Automation Library of Process Objects, publication <a href="#">PROCES-RM002</a>	Provides general considerations for the Rockwell Automation Library of Process Objects.
FactoryTalk® View Machine Edition User Manual, publication <a href="#">VIEWME-UM004</a>	Provides details on how to use this software package for creating an automation application.
FactoryTalk View Site Edition User Manual, publication <a href="#">VIEWSE-UM006</a>	Provides details on how to use this software package for developing and running human-machine interface (HMI) applications that can involve multiple users and servers, distributed over a network.
Logix5000™ Controllers Add-On Instructions Programming Manual, publication <a href="#">1756-PM010</a>	Provides information for designing, configuring, and programming Add-On Instructions.

You can view or download publications at <http://www.rockwellautomation.com/literature/>. To order paper copies of technical documentation, contact your local Allen-Bradley distributor or Rockwell Automation sales representative.

**Notes:**

# Interlocks with First Out and Bypass (P\_Intlk)

The P\_Intlk (Interlocks with First Out and Bypass) Add-On Instruction is used to collect (sum up) the interlock conditions that stop or de-energize a running or energized piece of equipment and prevent it from starting or being energized. Interlocks are always evaluated to de-energize equipment. For permissive conditions that must be made to start the equipment, but are ignored once the equipment is running, use the Permissives (P\_Perm) Add-On Instruction.

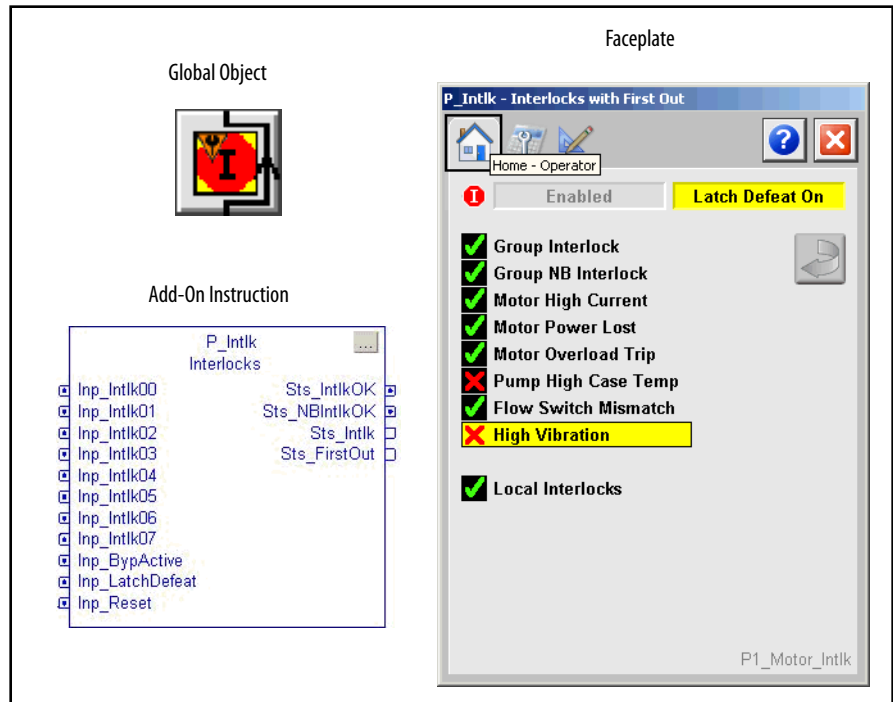

## Guidelines

Use this instruction in these situations:

- You have multiple interlock conditions or cascaded interlock conditions (an interlock hierarchy) that stop some equipment (motor, valve, drive) or keep it from starting. Link the conditions to P\_Intlk inputs, and link the P\_Intlk status bits to the Inp\_IntlkOK and Inp\_NBIntlkOK inputs of the equipment.
- You need a first-out indication of the interlock condition that shuts down the equipment.
- You want configurable text descriptions of shutdown conditions or other features of the P\_Intlk faceplate.

Do **not** use this instruction in these situations:

- You have conditions that prevent the equipment from starting, but are ignored once the equipment is running. These conditions are permissive, not interlock conditions. Use the P\_Perm instruction instead.
- You have only one interlock condition for the equipment. Connect the condition directly to the interlock input on the device.

## Functional Description

The following diagram shows the functional characteristics of the P\_Intlk Add-On Instruction.

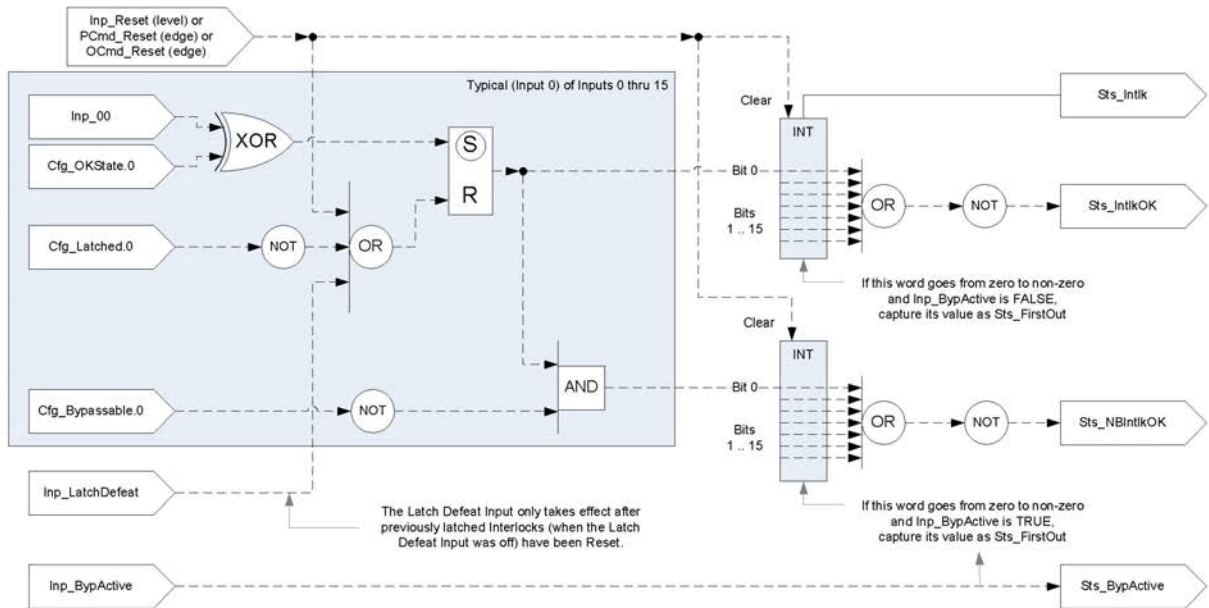

The primary operations of the P\_Intlk Add-On Instructions and its faceplate are the following:

- Interlock input OK Check: Each input is compared with its configured OK state. If the input is not in its OK state, it raises an interlock condition unless bypassed by Maintenance. (See Interlock Bypass on page 8.)
- Interlock Condition Latching: If the input is configured as latched, the interlock condition is latched in until reset unless the latch defeat input is true. See Latch Defeat on page 9. If the input is not configured as latched, the interlock condition clears when the input is again in its OK state.
- Interlock Bypass: If the input is configured as able to be bypassed and interlocks are bypassed, the input does not raise an interlock condition, even if it is not in its OK state. If the input is configured as not able to be bypassed or if interlocks are not bypassed, the input raises an interlock condition.

Engineering configures which interlocks are allowed to be bypassed. Maintenance then picks the ones to bypass from the interlocks that are allowed by Engineering.

- First Out: If no interlock conditions are raised (OK to run), the first interlock condition to be raised is marked as the first out. If multiple such interlock conditions are raised in the same scan, they are all marked as first out.



- **Latch Defeat:** A latch defeat function is provided to reduce the number of operator actions that are required to start equipment. The latch defeat input is set when the equipment is not running. When the latch defeat input is true, the latched configuration of inputs is ignored, and all interlock conditions clear when their corresponding inputs are in their OK states. This action saves the operator from having to reset before starting the equipment. When the equipment starts, the latch defeat input is turned off. Then, if an interlock condition configured as latched shuts down the equipment, it remains latched until reset.

---

**IMPORTANT** To prevent loss of information about what shut down the equipment, the latch defeat input is not processed until after any latched interlocks (that occurred when the latch defeat was off) have been reset.

---

- **Summary Status:** The P\_Intlk Add-On Instruction summarizes its 16 interlock input conditions into two primary status bits: Sts\_IntlkOK, which indicates that all interlock conditions are clear (ready to run), and Sts\_NBIntlkOK, which indicates that all interlock conditions that cannot be bypassed are clear (ready to run if interlocks are bypassed).

---

**IMPORTANT** The downstream equipment instructions determine whether or not interlocks are bypassed. The P\_Intlk instruction simply provides the two summary status bits. These 2 bits are to be wired or mapped to the equipment control logic.

---

- **Faceplate:** The P\_Intlk Add-On Instruction faceplate displays the interlock condition state of each input and whether it is bypassed, and shows the overall interlock (summary) status. The Engineering tab of the faceplate lets you configure the P\_Intlk Add-On Instruction for OK state configuration, latch configuration, configuration of interlocks that can be bypassed, and the text that is associated with each interlock condition input. You can also configure a navigation tag for each interlock condition. If you enable navigation, the condition text on the Operator tab of the faceplate can be clicked to access the faceplate for the corresponding tag.

## Required Files

Add-On Instructions are reusable code objects that contain encapsulated logic that can streamline implementing your system. Using this code allows you to create your own instruction set for programming logic as a supplement to the instruction set provided natively in the ControlLogix® firmware. An Add-On Instruction is defined once in each controller project, and can be instantiated multiple times in your application code as needed.

## Controller File

The P\_Intlk\_3\_5-00\_AOIL5X Add-On Instruction must be imported into the controller project to be used in the controller configuration. The service release number (boldfaced) can change as service revisions are created.

## Visualization Files

This Add-On Instruction has associated visualization files that provide a common user interface. These files can be downloaded from the Product Compatibility and Download Center at <http://www.rockwellautomation.com/rockwellautomation/support/pcdc.page>.

---

**IMPORTANT** The visualization file dependencies require Process Library content imports to occur in a specific order as reflected in the following tables:

- Images
  - Global Objects
  - Standard Displays
  - HMI Tags
  - Macros
- 

Images are external graphic files that can be used in displays. They must be imported for FactoryTalk View to make use of them.

When PNG files are imported, they are renamed by FactoryTalk View with a .bmp file extension, but retain a .png format.

**Table 2 - Visualization Files: Images (.png)**

FactoryTalk View SE Software	FactoryTalk View ME Software	Description
All .png files in the images folder	All .png files in the images folder	These are the common icons used in the global objects and standard displays for all Process Objects.

The Global Object files (.ggfx file type) in the following table are Process Library display elements that are created once and referenced multiple times on multiple displays in an application. When changes are made to a Global Object, all instances in the application are automatically updated.

**Table 3 - Visualization Files: Global Objects (.ggfx)**

FactoryTalk View SE Software	FactoryTalk View ME Software	Description
(RA-BAS) Common Faceplate Objects	(RA-BAS-ME) Common Faceplate Objects	Global objects used on process object faceplates.
(RA-BAS) Process Interlock Objects	(RA-BAS-ME) Process Interlock Objects	Global objects used for managing interlocks and permissives on process object faceplates.

The Standard Display files (.gfx file type) in the following table are the Process Library displays that you see at runtime.

**Table 4 - Visualization Files: Standard Displays (.gfx)**

FactoryTalk View SE Software	FactoryTalk View ME Software	Description
(RA-BAS) P_Intlk-Faceplate	(RA-BAS-ME) P_Intlk-Faceplate	The faceplate that is used for the object
(RA-BAS) Process Interlock Family-Help	(RA-BAS-ME) Process Interlock Family-Help	The Help display for Interlock objects

HMI Tags are created in a FactoryTalk View ME application to support tab switching on Process Library faceplates. The HMI tags may be imported via the comma-separated values file (.csv file type) in the following table.

**Table 5 - Visualization Files: HMI Tags (.csv)**

FactoryTalk View SE Software	FactoryTalk View ME Software	Description
N/A	FTVME_PlantPaxLib_Tags_3_5_XX.csv where XX = the service release number.	These tags must be imported into the FactoryTalk View ME project to support switching tabs on any Process Object faceplate.

In a FactoryTalk View SE application, a macro is a series of commands stored in a text file. In FactoryTalk View ME application, a macro is a list of tag assignments stored in a text file. The following table lists the Macros (.mcr file type) used by the Process Library.

**Table 6 - Visualization Files: Macros (.mcr file)**

FactoryTalk View SE Software	FactoryTalk View ME Software	Description
NavToObject	N/A	This macro must be imported into the FactoryTalk View SE project to support faceplate-to-faceplate navigation by name.

## Controller Code

This section describes the parameter references for this Add-On Instruction.

### Interlocks Input Structure

Input parameters include the following:

- Input data elements (Inp\_) are typically used to connect field inputs from I/O modules or signals from other objects.
- Configuration data elements (Cfg\_) are used to set configurable capabilities and features of the instruction.
- Commands (PCmd\_, OCmd\_, MCmd\_) are used by program logic, operators, and maintenance personnel to request instruction actions.
- Settings (PSet\_, OSet\_, MSet\_) are used by program logic, operators, and maintenance personnel to establish runtime setpoints, thresholds, and so forth. A Setting (without a leading P, O, or M) establishes runtime settings regardless of role or mode.

**Table 7 - P\_Intlk Input Parameters**

Input Parameter	Data Type	Alias For	Default	Description
EnableIn	BOOL		1	<p><b>Ladder Diagram:</b> If the rung-in condition is true, the instruction's Logic routine executes. If the rung-in condition is false, the instruction's EnableInFalse routine executes.</p> <p><b>Function Block Diagram:</b> If true, or not connected, the instruction's Logic routine executes. If the parameter is exposed as a pin and wired, and the pin is false, the instruction's EnableInFalse routine executes.</p> <p><b>Structured Text:</b> No effect. The instruction's Logic routine executes.</p>
Inp_Intlk00...Inp_Intlk15	BOOL	Wrk_Inp.0...Wrk_Inp.15	0	Interlock condition inputs - If Input is not in the OK state that is defined by Cfg_OKState and not bypassed (if able to be bypassed per Cfg_Bypassable), then the appropriate interlock status (Sts_IntlkOK and Sts_NBIntlkOK) are set to 0 to stop the equipment.
Inp_BypActive	BOOL		0	1 = Interlock Bypassing is active.
Inp_LatchDefeat	BOOL		0	Latch Defeat 1 = Do not latch inputs even if configured for latching.
Inp_Reset	BOOL		0	Input parameter that is used to programmatically reset latched interlocks. When set to 1, all latched interlocks that require a reset are reset.
Cfg_OKState	INT		2#0000_0000_0000_0000	Bits determine the state (0 or 1) of each input that is OK to run.
Cfg_Latched	INT		2#0000_0000_0000_0000	Set bits determine the conditions that are latched (sealed in).
Cfg_Bypassable	INT		2#0000_0000_0000_0000	Set bits determine the conditions that can be bypassed.
Cfg_HasNav	INT		2#0000_0000_0000_0000	Set bits determine the Navigation buttons that are enabled.
Cfg_PCmdClear	BOOL		1	<p>When this parameter is 1, program commands are cleared once they are acted upon. When set to 0, program commands remain set until cleared by the application program logic.</p> <p><b>IMPORTANT:</b> Clearing this parameter online can cause unintended program command execution.</p>

**Table 7 - P\_Intlk Input Parameters**

Input Parameter	Data Type	Alias For	Default	Description
MSet_Bypass00... MSet_Bypass15	BOOL	Wrk.MSet.0...Wrk.MSet.15	0	Maintenance Bypass Toggle for Interlock Cond. 00...Cond.15: 1 = Bypass. Maintenance uses these bits to determine which individual interlocks are bypassed.
PCmd_Reset	BOOL		0	<ul style="list-style-type: none"> <li>Set PCmd_Reset to 1 to reset latched interlocks</li> <li>This parameter is reset automatically if Cfg_PCmdClear = 1</li> </ul>
OCmd_Reset	BOOL		0	Operator Command to reset latched interlocks.

## Interlocks Output Structure

Output parameters include the following:

- Status data elements (Sts\_) are bit outputs of the instruction for use by the HMI. Status bits can also be used by other application logic.
- Ready data elements (Rdy\_) are bit outputs of the instruction that are used by the HMI to enable or disable command buttons and entry fields.

**Table 8 - P\_Intlk Output Parameters**

Output Parameter	Data Type	Description
EnableOut	BOOL	Enable Output: The EnableOut signal is not manipulated by this instruction. Its output state always reflects EnableIn input state.
Sts_IntlkOK	BOOL	Overall Interlock Status: 1 = OK to run 0 = Stop
Sts_NBIntlkOK	BOOL	Interlock (cannot be bypassed) Status (1 = All NB interlocks OK to run).
Sts_BypActive	BOOL	1 = Interlock Bypassing Active (interlocks that can be bypassed are ignored).
Sts_Intlk	INT	Individual Interlock Status: bit = 1 = Stop bit = 0 = OK
Sts_FirstOut	INT	Interlock First Out Status (bit = 1 is First Not-OK condition).
Rdy_Reset	BOOL	1 = Ready to receive OCmd_Reset (reset required).
P_Intlk	BOOL	Unique Parameter Name for auto-discovery.

## Interlocks Local Configuration Tags

Configuration parameters that are array, string, or structure data types cannot be configured as parameters for Add-On Instructions. Configuration parameters of these types appear as local tags to the Add-On Instruction. Local tags can be configured through the HMI faceplates or in Studio 5000 Logix Designer® application. Open the instruction logic of the Add-On Instruction instance and then open the Data Monitor on a local tag to accomplish this configuration. These parameters cannot be modified by using controller logic or Logix Designer application export/import functionality.

**Table 9 - Local Configuration Tags**

Tag Name	Data Type	Default	Description
Cfg_CondTxt Cfg_CondTxt[0] Cfg_CondTxt[1]... Cfg_CondTxt[15]	STRING_20[16]	'Enter Description #0' ''	Short HMI descriptions of 16 interlock conditions.
Cfg_Desc	STRING_40	'Interlocks with First Out'	Description for display on HMI. This string is shown in the title bar of the faceplate.
Cfg_Label	STRING_20	'Interlocks'	Label for graphic symbol that is displayed on HMI. This string appears on the graphic symbol.
Cfg_NavTag	STRING_NavTag[16]	''	Tag names for destinations of 16 navigation buttons. <b>IMPORTANT:</b> This function does not apply to FactoryTalk View ME Software.
Cfg_Tag	STRING_20	'P_Intlk'	Tag name for display on the HMI. This string is shown in the title bar of the faceplate.

## Operations

This section describes the primary operations for Add-On Instructions.

### Modes

The P\_Intlk Add-On Instruction does not have modes and does not contain a P\_Mode instruction instance. The Operator and Program reset commands for the latched inputs are accepted at any time.

### Alarms

The P\_Intlk Add-On Instruction does not generate any alarms. The individual input conditions can be alarmed, if necessary, in other logic before they are sent to the inputs of the P\_Intlk instruction. In many applications, status bits from P\_AIn Analog Input or P\_DIn Discrete Input instructions are sent to the P\_Intlk inputs, and those instructions provide alarms.



**ATTENTION:** Status bits are normally used as interlock conditions. Use alarm bits as interlock conditions only if you intend that the interlock condition be ignored when the corresponding alarm is disabled, suppressed, or shelved.

## Simulation

The P\_Intlk Add-On Instruction does not have a Simulation capability.

## Execution

The following table explains the handling of instruction execution conditions.

Condition	Description
EnableIn False (false rung)	Processing for EnableIn False (false rung) is handled by setting the summary All interlocks OK and All interlocks (cannot be bypassed) OK status outputs to false (0). The individual interlock bit status and first out outputs are left in their last state.
Powerup (prescan, first scan)	The latch and first out states of the P_Intlk Add-On Instruction are maintained through a power-down/power-up or Run/Program/Run cycle. Any commands that are received before the first scan are discarded.
Postscan (SFC transition)	No SFC postscan logic is provided.

See the Logix5000 Controllers Add-On Instructions Programming Manual, publication [1756-PM010](#), for more information.

## Programming Example

This example uses the P\_Intlk instruction to concentrate the interlock conditions that allow the functioning of the refiner plates that are used for grinding wood as part of the pulp manufacturing process.

Perform the following steps to import an Add-On Instruction to your project.

1. Right-click 'Add-On Instructions' and select 'Import Add-On Instruction...'
2. On the Import Add-On Instruction dialog box, select the P\_Intlk instruction and click Import.
3. Add the P\_Intlk instruction to your project:
  - a. Click the Add-On tab on the Language Element toolbar.
  - b. Click the P\_Intlk instruction.
  - c. Also add the P\_Motor instruction that controls the refiner plates.
4. Double-click the interlock instruction name and create the tag name for it. The naming convention that makes navigation from the motor faceplate work automatically is to use the motor's tag name followed by \_Intlk.
5. Create the input references necessary to confirm the appropriate operation of the refiner plates and create their appropriate tags.
6. Expose the Sts\_BypActive pin on P\_Motor. Wire this pin back to Inp\_BypActive on P\_Intlk, and mark this wire 'Assume Data Available'.

The following image is what the instruction looks like when connected correctly.

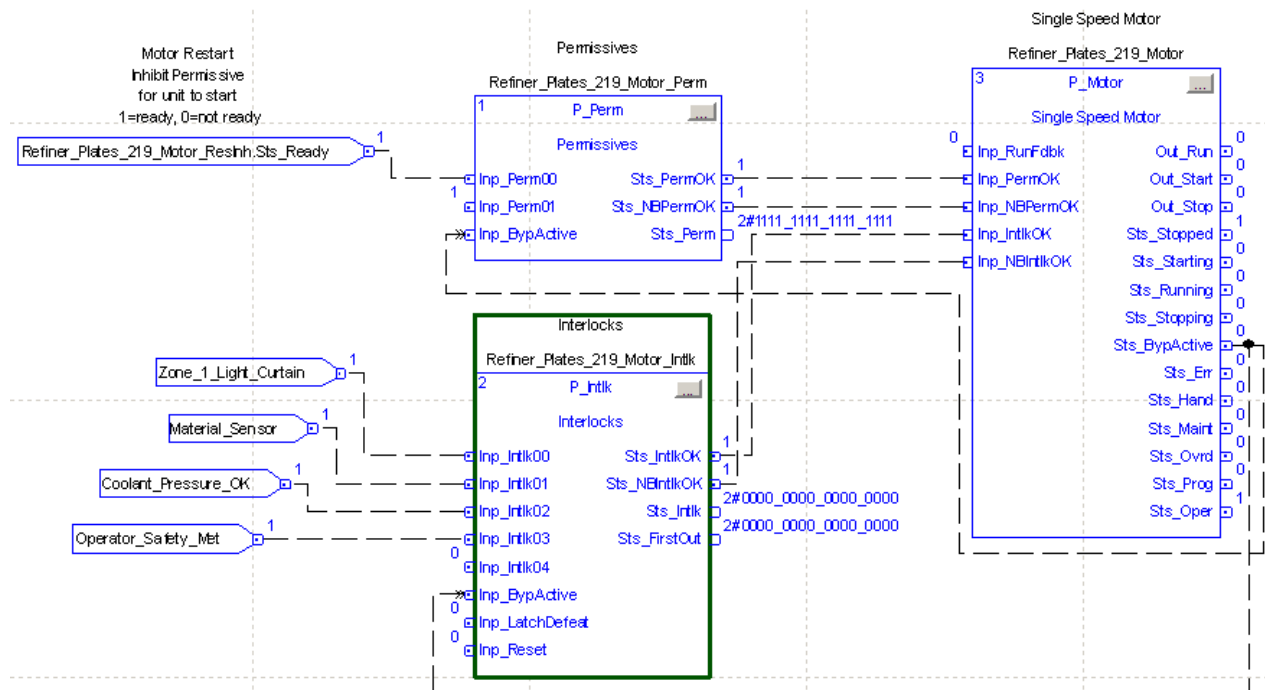

7. Save, download, and run your Logix application.
8. In your HMI application, add a P\_Motor motor graphic object from P\_Motor Graphics Library.ggfx and right-click it.
9. From the list, select “Global Object Parameter Values”
10. Associate the created tag for P\_Motor of the Refiner Plates in the controller with the graphic object in the HMI:
  - a. On the first line of the Global Object Parameter Value table, type its name.
  - b. On the second line, type the name of the shortcut to the controller enclosed by brackets.
  - c. Enter additional parameters as desired.



Because of the naming convention, the connection is made automatically and the interlock settings are associated with the refiner plates motor.

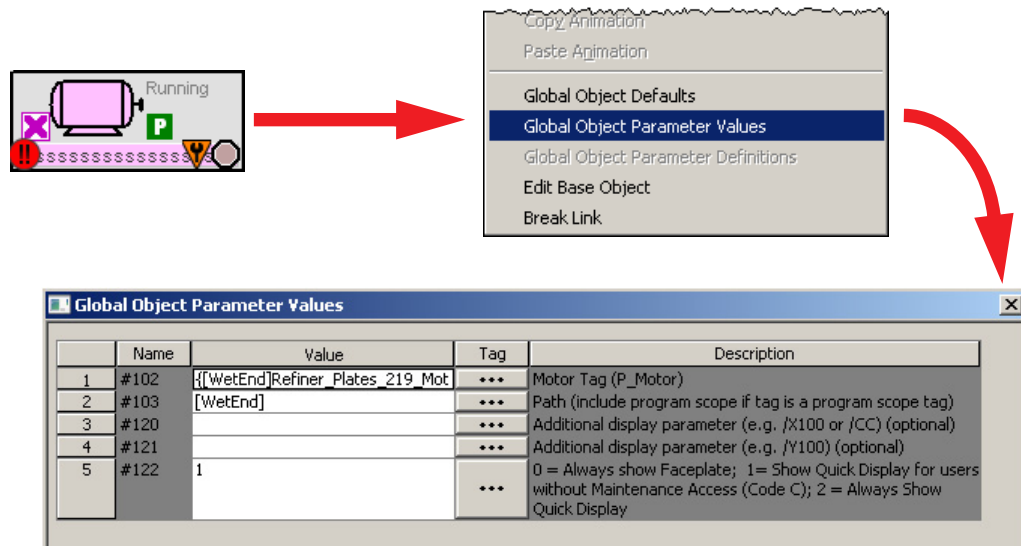

11. Save your HMI application.
12. Run your HMI application and click the motor graphic object. If the Quick display appears, click the 'go to faceplate' button.
13. On the P\_Motor faceplate, click the Engineering tab and go to page 2.
14. Check "Enable navigation to interlock object".

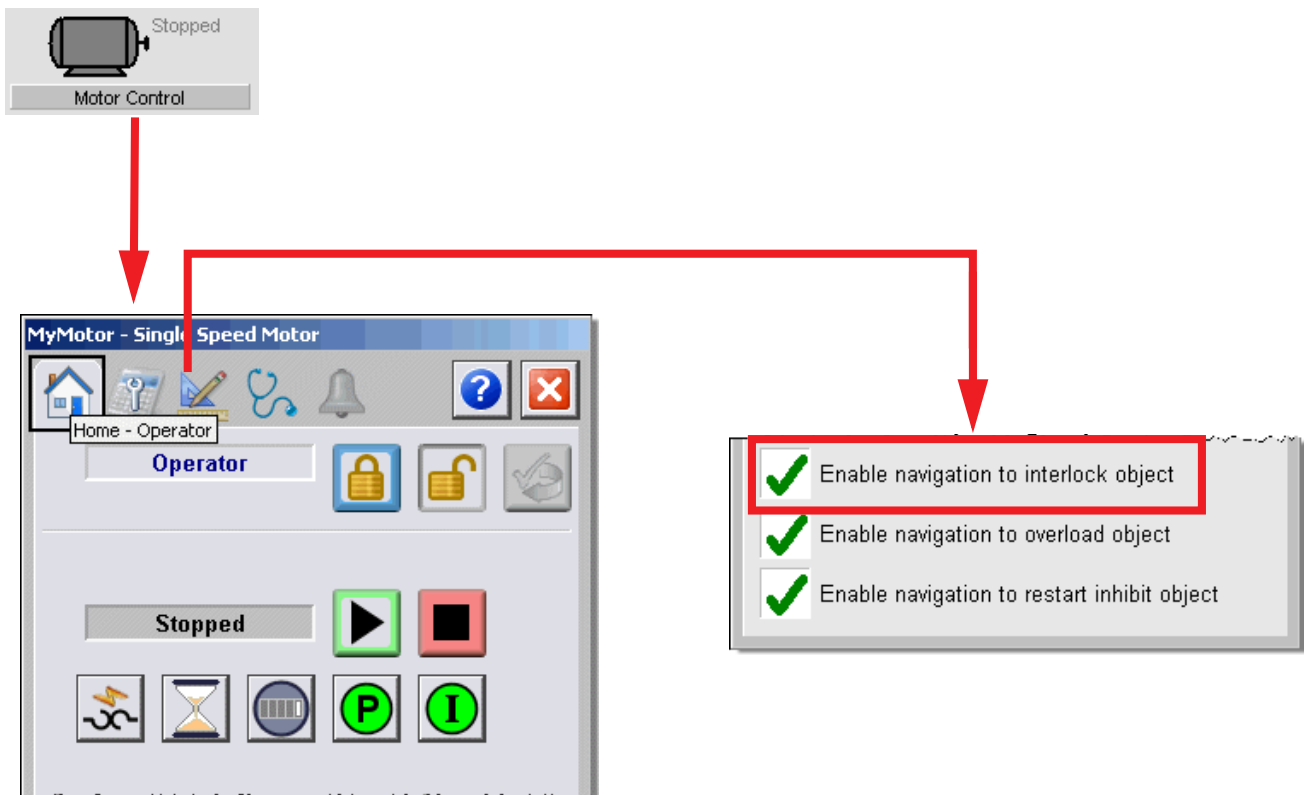

The Interlock button is enabled.

15. On the P\_Motor faceplate, click the Interlock button to open the P\_Intlk faceplate. On the P\_Intlk faceplate, click the Engineering tab, and perform the following:
  - a. Name the interlocks accordingly.
  - b. Select the appropriate state under 'OK State'.
  - c. Indicate which interlocks can be bypassed.
  - d. Indicate which interlocks must be reset.

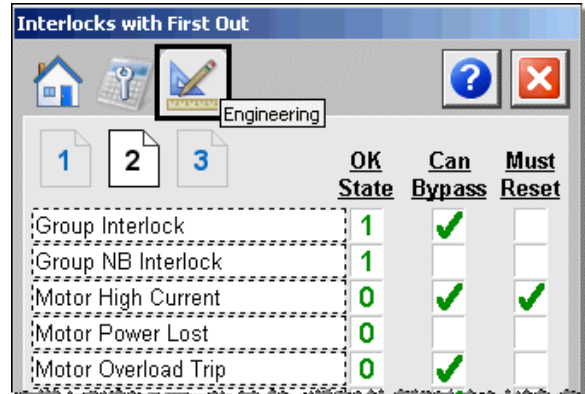
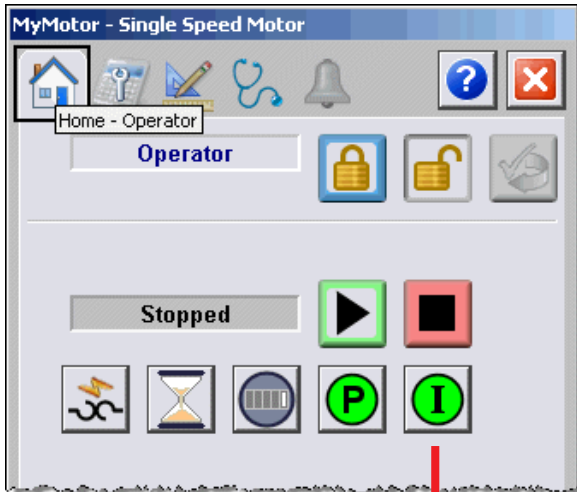

**IMPORTANT** Specific inputs can be bypassed on the maintenance tab based on selections on page 2 of the Engineering tab (see [Engineering Tab Page 2 on page 30](#)). When bypass is enabled, it bypasses only those inputs set on the Maintenance tab ([Maintenance Tab on page 27](#)).

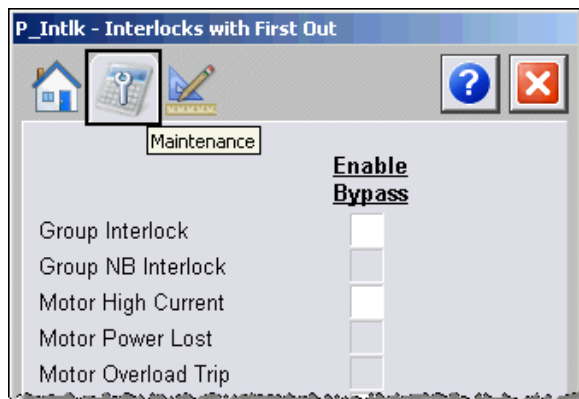

## Display Elements

A display element (global object) is created once and can be referenced multiple times on multiple displays in an application. When changes are made to the original (base) object, the instantiated copies (reference objects) are automatically updated. Use of global objects, with tag structures in the ControlLogix system, aid consistency and save engineering time.

Display Element Name	Display Element	Description
GO_P_Intlk		Standard Interlock Global Object.

Graphic symbols are provided for use on end-user process graphic displays. Interlock graphic symbols have the following common attributes.







The Interlock graphic symbol displays the current summary state of the interlocks and whether interlocks that can be bypassed are bypassed. These indicators are described in detail in [Status and Bypass Indicators on page 20](#).

The overall graphic symbol includes a touch field that opens the instruction faceplate. In the SE version of the library, pausing the pointing device over the graphic symbol displays a tooltip that describes the function of the symbol.



## Status and Bypass Indicators

The Status Indicator icon changes color and shape that is based on the state of the interlock input conditions, and the Bypass Indicator shows whether interlock conditions that can be bypassed are currently being bypassed.

Background	Description
	Not ready to run or energize. One or more interlock conditions are not OK.
	Ready to run or energize. One or more conditions that can be bypassed are not OK, but these conditions are bypassed. All conditions that cannot be bypassed are OK.
	Ready to run or energize. All interlock conditions are OK.
	Ready to run or energize, and all interlock conditions are OK, but be aware that conditions that can be bypassed are being bypassed and the equipment is not shut down.

The P\_Intlk instruction does not have bypass commands, as they are in the associated device instruction. If you would like the graphic symbol and faceplate to display the equipment's bypass state, connect the equipment's bypass status to the P\_Intlk instructions Inp\_ByActive input.

## Using Display Elements

Normally, navigation to the P\_Intlk faceplate is included on the faceplate for the associated motor, drive, or other object. However, a graphic symbol for the P\_Intlk instruction can be found in the global object file (RA-BAS) Process Interlock Objects.ggfx. Follow these steps to use the graphic symbol.

1. Copy the global object from the global object file and paste it in the display file.

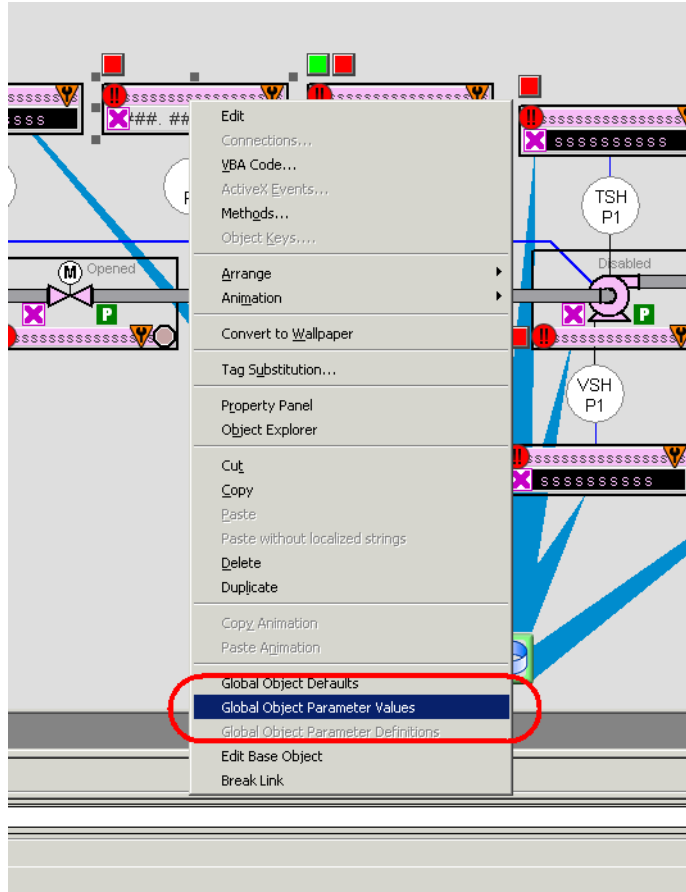

- In the display, right-click the global object and choose Global Object Parameter Values.

The Global Object Parameter Values dialog box appears.

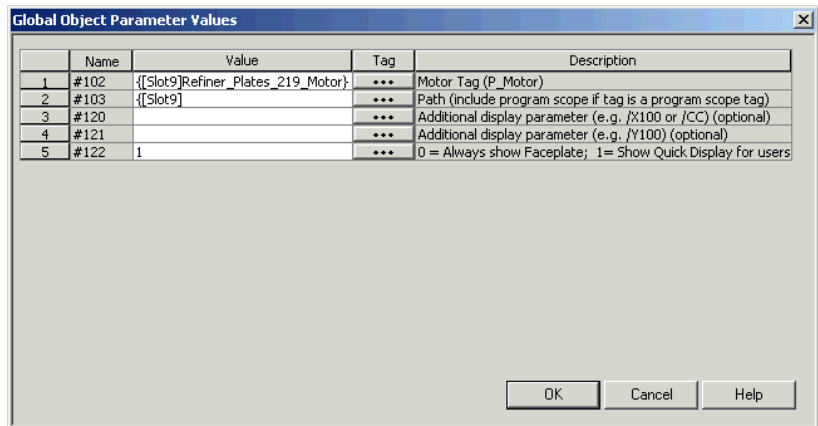

The global object parameters are as follows.

Parameter	Required	Description
#102	Y	Object tag to point to the name of the associated object Add-On Instruction in the controller.
#103	Y	Path that is used for display navigation features to other objects. Include program scope if tag is a program scope tag.
#120	N	Additional parameter to pass to the display command to open the faceplate. Typically used to define position for the faceplate.
#121	N	Additional parameter to pass to the display command to open the faceplate. When you define the X and Y coordinate, separate parameters so that #120 defines X and #121 defines Y. This definition lets these same parameters to be used in subsequent display commands that originate from the faceplate.

- Type the tag or value in the Value column as specified in the Description column.

**TIP** Click the ellipsis (...) to browse and choose a tag.  
Values for items marked '(optional)' can be left blank.

- Click OK.

## Faceplate

The P\_Intlk faceplate consists of three tabs and each tab consists of one or more pages.

Each faceplate contains the value of local configuration tags Cfg\_Tag and Cfg\_Desc in the title bar.

### Tag - Description

The Operator tab is displayed when the faceplate is initially opened. Click the appropriate icon at the top of the screen to access a specific tab.

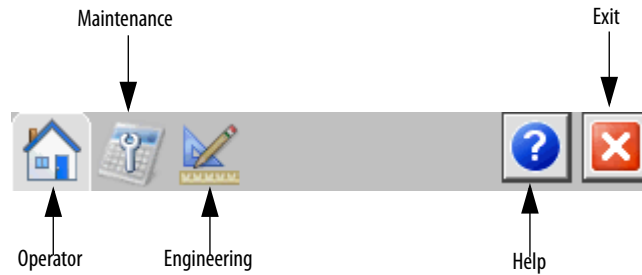

The faceplate provides the means for operators, maintenance workers, engineers, and others to interact with the P\_E300Ovld instruction instance. You can also view its status and values and manipulate it through its commands and settings. When a given input is restricted via FactoryTalk View security, the required user Security Code letter is shown in the faceplate description tables.

## Operator Tab

The Faceplate initially opens to the Operator (‘Home’) Tab. From here, an operator can monitor the device status.

The Operator tab shows the following information:

- A status indicator, identical to the one on the graphic symbol, shows the current interlock state (all conditions met, non-bypassed conditions met, or some conditions not met)
- Interlock Bypass status indicator
- Each configured interlock along with the current state of the interlock
- Latch Defeat status indicator

The following figure shows the Operator tab in a non-bypassed condition.

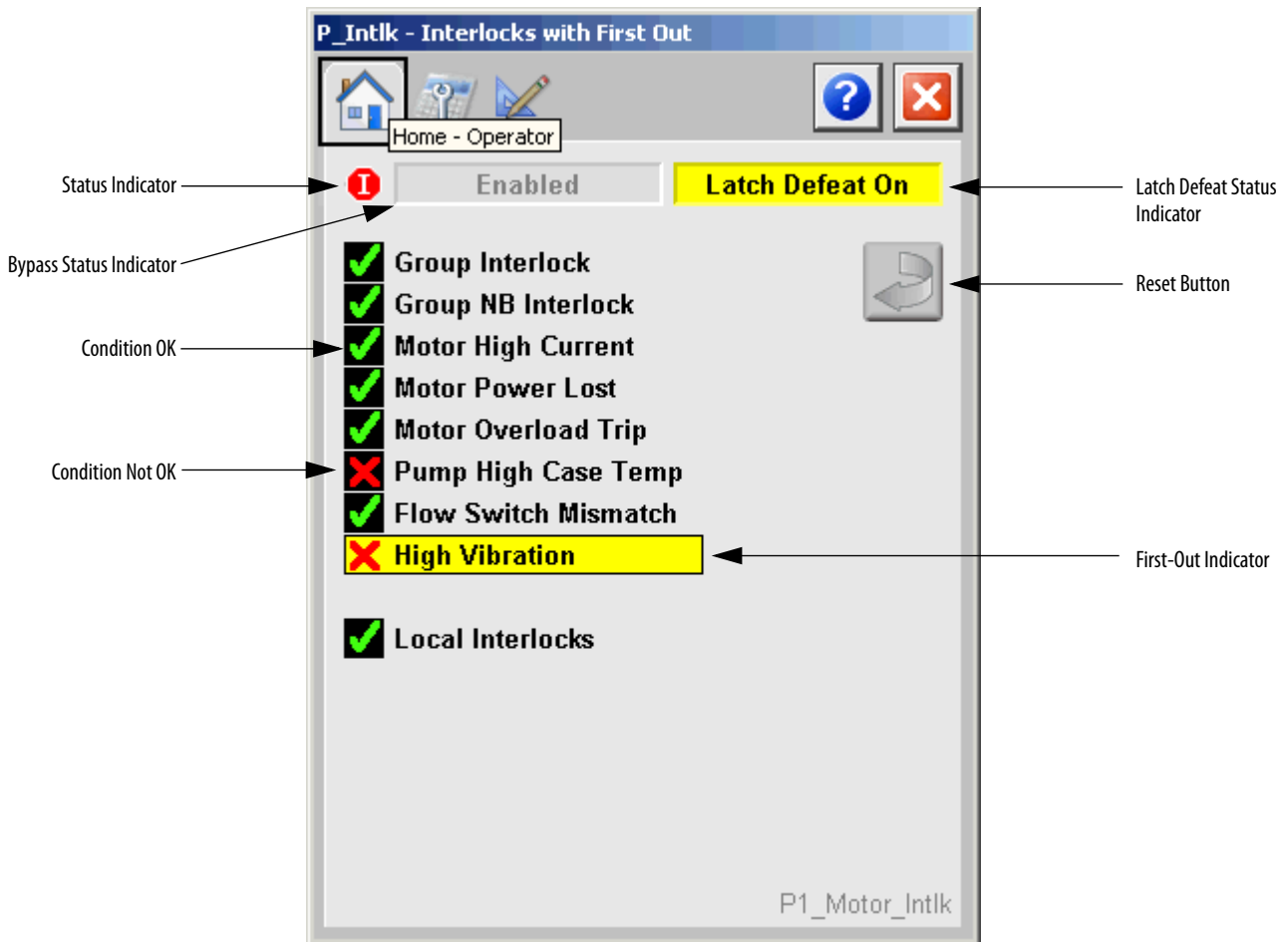

If navigation is enabled, click a condition to open the faceplate of the object that is associated with the condition.



The following figure shows the Operator tab in a bypassed condition.

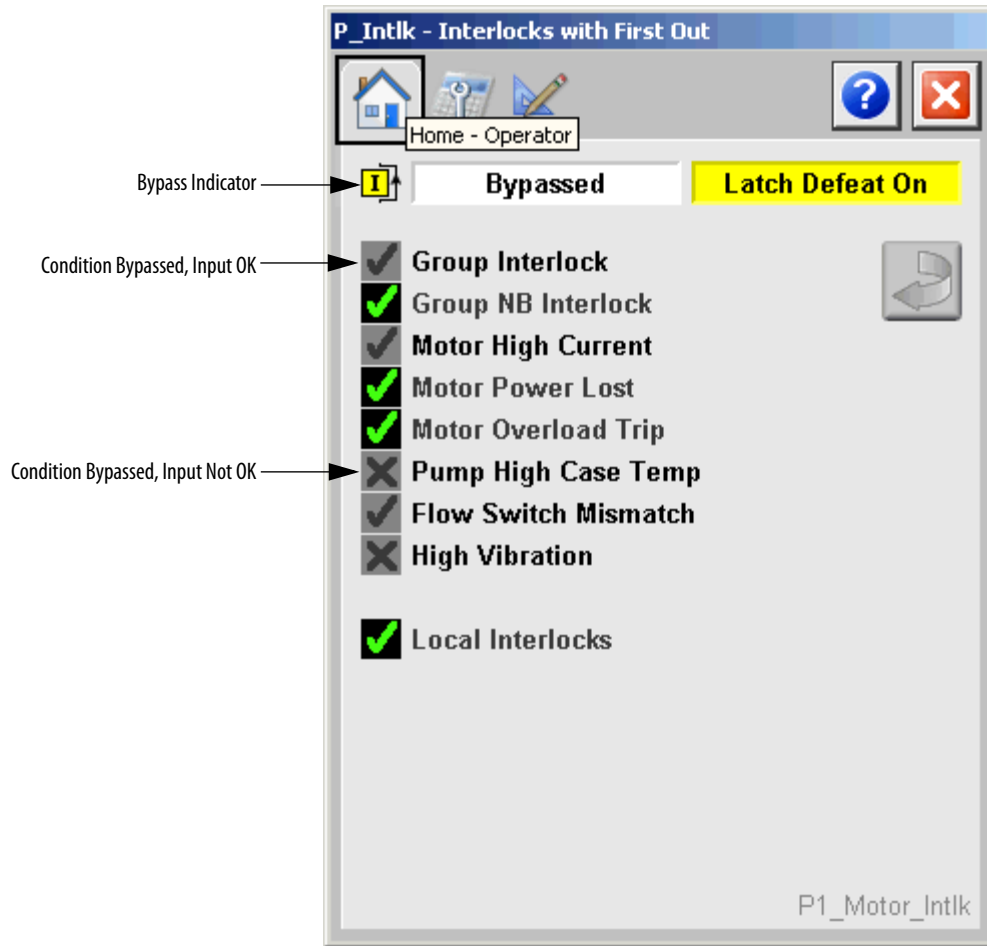





The following table lists the functions on the Operator tab.

**Table 10 - Operator Tab Description**

Function	Action	Security Required
	Resets interlocks that are latched.	Normal Operation of Devices (Code A)
Click Interlock Condition text	Click to open the faceplate for the associated tag. See <a href="#">Engineering Tab Page 3 on page 31</a> for information on how to enable navigation for interlock conditions.	None

**Table 11 - Operator Tab Status Indicators**

Indicator	Description
	Condition OK
	Condition Not OK
	Bypassed, but OK
	Not OK, but bypassed

## Maintenance Tab

Maintenance personnel use the information and controls on the Maintenance tab to adjust device parameters. They also troubleshoot and temporarily work around device problems, and disable the device for routine maintenance.

**IMPORTANT** Only interlocks with white checkboxes can be individually bypassed. These interlocks are set up with the 'Can Bypass' column on page 2 of the Engineering tab. (See [Engineering Tab Page 2 on page 30.](#))

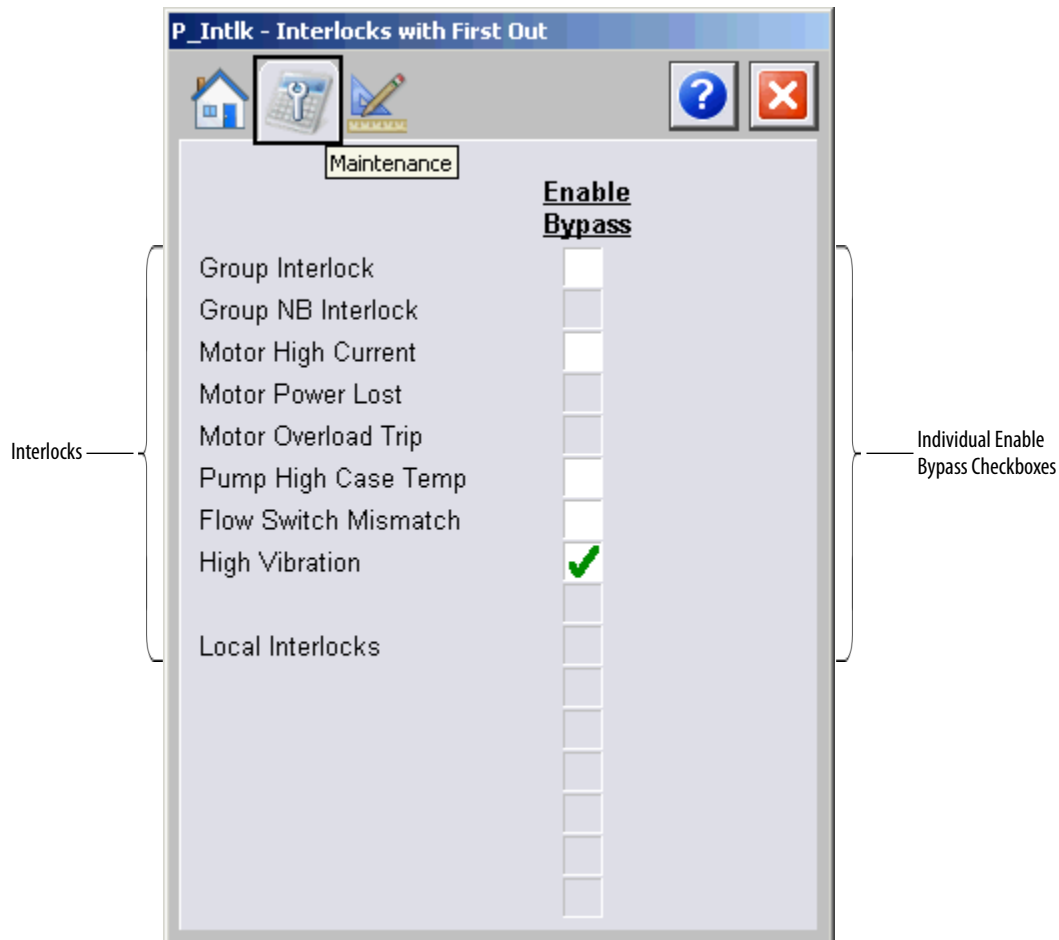

The following table lists the functions on the Maintenance tab.

**Table 12 - Maintenance Tab Descriptions**

Function	Action	Security	Configuration Parameters
Enable Bypass	Click an interlock condition that can be bypassed, one that has a white checkbox, to enable bypass of that individual interlock. See <a href="#">Engineering Tab Page 2 on page 30</a> for information on how to make interlock conditions active.	Bypass Permissives and Interlocks (Code H)	Cfg_Bypassable

## Engineering Tab

The Engineering tab provides access to device configuration parameters and ranges, options for device and I/O setup, displayed text, and faceplate-to-faceplate navigation settings, for initial system commissioning or later system changes.

The Engineering tab is divided into three pages.

### Engineering Tab Page 1

On page 1 of the Engineering tab, you can configure the description, label, and tag for the device.

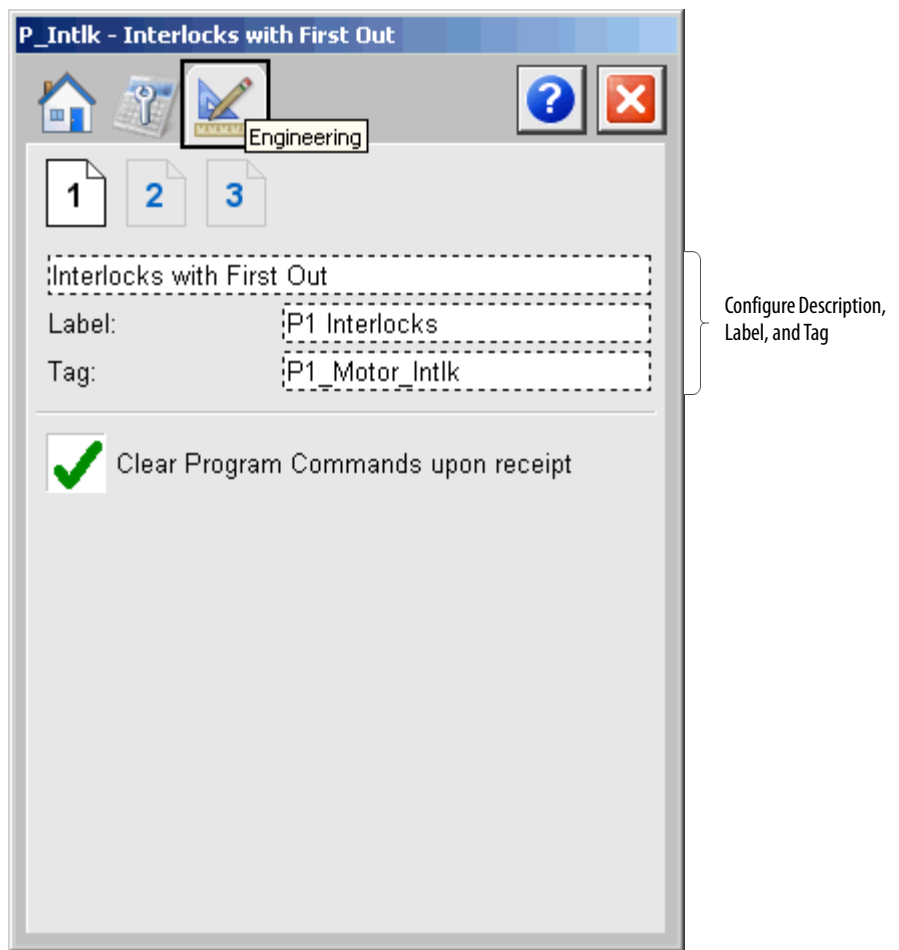

The following table lists the functions on page 1 of the Engineering tab.

**Table 13 - Engineering Tab Page 1 Descriptions**

Function	Action	Security	Configuration Parameters
Description	Type the text description of the interlock set. It appears on the title bar of the faceplate.	Engineering Configuration (Code E)	Cfg_CondTxt[0]...Cfg_CondTxt[15]
Label	Type the label to show on the graphic symbol.		Cfg_Label
Tag	Type the tag name to show on the faceplate and Tooltip. <b>IMPORTANT:</b> Pausing the mouse over this field displays a tool tip with the configured Logix tag/path.		Cfg_Tag
Clear Program Commands on Receipt	Check to clear Program commands on receipt.		Cfg_PCmdClear

Engineering Tab Page 2

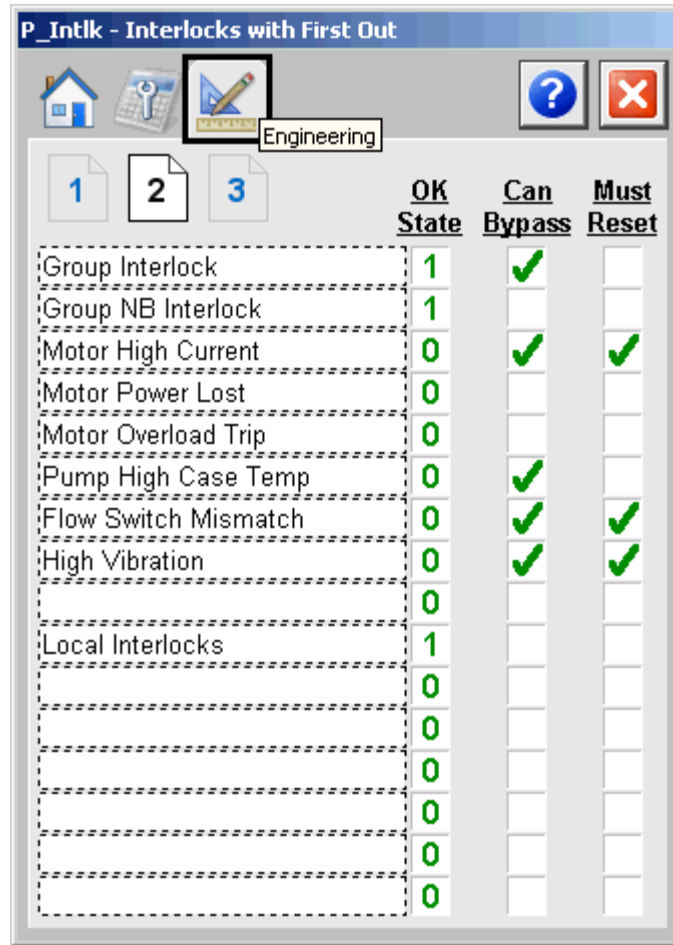

Up to 16 interlock inputs can be configured on page 2 of the Engineering tab. For each interlock, the following can be configured.

Table 14 - Engineering Tab Page 2 Descriptions

Function	Action	Security Required	Configuration Parameters
Descriptions	Type the text description of each interlock condition used. The interlocks with text entered appear on the Operator tab of the faceplate. If the text for a condition is empty (null), the interlock is not shown.	Engineering Configuration (Code E)	Cfg_Desc
OK State	Selects the state of the corresponding interlock that is the OK to Run state.		Cfg_OKState
Can Bypass	Check to indicate that the corresponding interlock can be bypassed. See <a href="#">Maintenance Tab on page 27</a> for information on bypassing interlocks.		Cfg_Bypassable
Must Reset	Check to indicate that the corresponding interlock is latched and must be reset.		Cfg_Latched

## Engineering Tab Page 3

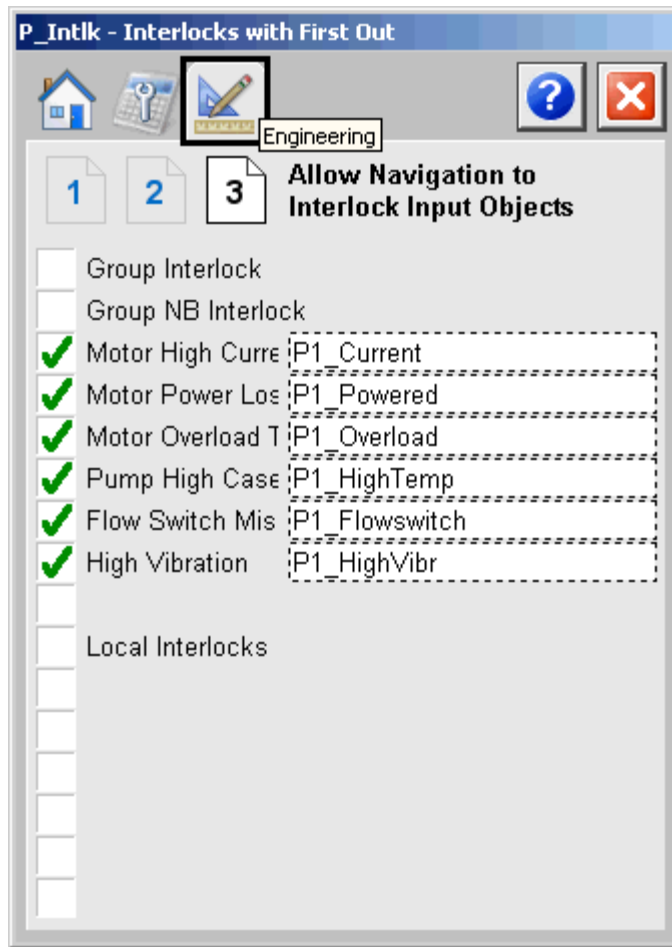

Navigation for the 16 interlock inputs is configured on page 3 of the Engineering tab. For each interlock, the following can be configured.









**Table 15 - Engineering Tab Page 3 Descriptions**

Function	Action	Security Required	Configuration Parameters
Allow Navigation to Interlock Input Objects	Check to enable navigation for the corresponding interlock input object.	Engineering Configuration (Code E)	Cfg_HasNav
Navigation Tag	Type the name of the tag to navigate to when the interlock description on the Operator tab is clicked.		Cfg_NavTag[0]...Cfg_NavTag[15]

## Interlock Faceplate Help

**Interlock and Permissive help** 

**Indicators**

-  One or more conditions not OK
-  Non-Bypassed conditions OK
-  All conditions OK, Bypass Active
-  All conditions OK
-  Condition OK
-  Condition Not OK
-  Bypassed, but OK
-  Not OK but bypassed

**First Interlock not OK**

**Interlock Command**

-  Reset all interlocks that have been configured as "Must Reset"





## Rockwell Automation Support

Rockwell Automation provides technical information on the Web to assist you in using its products.

At <http://www.rockwellautomation.com/support> you can find technical and application notes, sample code, and links to software service packs. You can also visit our Support Center at <https://rockwellautomation.custhelp.com/> for software updates, support chats and forums, technical information, FAQs, and to sign up for product notification updates.

In addition, we offer multiple support programs for installation, configuration, and troubleshooting. For more information, contact your local distributor or Rockwell Automation representative, or visit <http://www.rockwellautomation.com/services/online-phone>.

## Installation Assistance

If you experience a problem within the first 24 hours of installation, review the information that is contained in this manual. You can contact Customer Support for initial help in getting your product up and running.

United States or Canada	1.440.646.3434
Outside United States or Canada	Use the <a href="#">Worldwide Locator</a> at <a href="http://www.rockwellautomation.com/rockwellautomation/support/overview.page">http://www.rockwellautomation.com/rockwellautomation/support/overview.page</a> , or contact your local Rockwell Automation representative.

## New Product Satisfaction Return

Rockwell Automation tests all of its products to help ensure that they are fully operational when shipped from the manufacturing facility. However, if your product is not functioning and needs to be returned, follow these procedures.

United States	Contact your distributor. You must provide a Customer Support case number (call the phone number above to obtain one) to your distributor to complete the return process.
Outside United States	Please contact your local Rockwell Automation representative for the return procedure.

## Documentation Feedback

Your comments will help us serve your documentation needs better. If you have any suggestions on how to improve this document, complete this form, publication [RA-DU002](#), available at <http://www.rockwellautomation.com/literature/>.

Rockwell Automation maintains current product environmental information on its website at <http://www.rockwellautomation.com/rockwellautomation/about-us/sustainability-ethics/product-environmental-compliance.page>.

Rockwell Otomasyon Ticaret A.Ş., Kar Plaza İş Merkezi E Blok Kat:6 34752 İçerenköy, İstanbul, Tel: +90 (216) 5698400

**[www.rockwellautomation.com](http://www.rockwellautomation.com)**

### Power, Control and Information Solutions Headquarters

Americas: Rockwell Automation, 1201 South Second Street, Milwaukee, WI 53204-2496 USA, Tel: (1) 414.382.2000, Fax: (1) 414.382.4444  
Europe/Middle East/Africa: Rockwell Automation NV, Pegasus Park, De Kleetlaan 12a, 1831 Diegem, Belgium, Tel: (32) 2 663 0600, Fax: (32) 2 663 0640  
Asia Pacific: Rockwell Automation, Level 14, Core F, Cyberport 3, 100 Cyberport Road, Hong Kong, Tel: (852) 2887 4788, Fax: (852) 2508 1846

Publication SYSLIB-RM004H-EN-E - February 2017

Supersedes Publication SYSLIB-RM004G-EN-E - October 2015

Copyright © 2017 Rockwell Automation, Inc. All rights reserved. Printed in the U.S.A.