

Trusted Dual I/O Companion Slot Cables

Product Overview

This document provides detailed information for the types of Trusted® Dual input/output (I/O) (typically 60 Channel) Cables available within the Companion Slot group. These types of cable provide connection facilities between the Trusted analogue and digital input/output modules, and Trusted Field Termination Assemblies (FTAs) as required.

The types of Trusted I/O 60 Channel Companion Slot Cables currently available are listed in Table 1 below.

Cable Type	Description
TC-701-02-xmx	I/O Companion Slot, Internal, 60 Channel Input to FTA
TC-701-03-xmx	I/O Companion Slot, Internal, 60 Channel Input to FTA (UL)
TC-702-02-xmx	I/O Companion Slot, Internal, 60 Channel Input to Flying Lead
TC-702-03-xmx	I/O Companion Slot, Internal, 60 Channel Input to Flying Lead (UL)
TC-704-02-xmx	I/O Companion Slot, External, 60 Channel Input to Flying Lead
TC-704-03-xmx	I/O Companion Slot, External, 60 Channel Input to Flying Lead (UL)

Table 1 Trusted I/O Companion Slot Cables

The cables are manufactured to user's requirements, therefore length and type of cable insulation must be specified. Length must be specified to the nearest 0.5 m in the format xmx, e.g. 2m0 for a cable length of 2.0 m. This detail must be added to the end of the part number. The type of cable insulation forms part of the cable part number and is denoted by 02 for Low Smoke Zero Halogen (LSZH) or 03 for UL Certified cable material. 02 is also flame retardant to IEC 60332-3 Cat A. Poly-Vinyl-Chloride (PVC) covered cables are not available. When ordering cables, it is recommended that the user supplies the details as shown in Table 1.

The maximum recommended I/O cable length is 15 m. Cables longer than this may be specified if necessary but may suffer from voltage drop, offset, crosstalk and noise and will present materials handling problems.

Internal cables are designed for cables where they are terminated in adjacent enclosures. If the cable needs to leave the enclosure environment, the external cable has more protection. Note that the 'external' cables are not armoured and are not suitable for truly external use and must still be

treated with care. These cables will need protection when drawn through a cable route, and should also not be pulled by the connector(s). They should enter cabinets through transit/compression blocks and cannot be glanded.

The Companion Slot cables described in this document allow hot-swap modules to be sited in adjacent slots using a double width chassis socket. For SmartSlot cables, allowing a remote slot to be assigned as necessary for a hot-swap, refer to Trusted Dual I/O SmartSlot Cables, publication [ICSTT-RM314](#) (PD-TC600).

This document describes cables for dual modules (typically 60 channel). For Triple Modular Redundant (TMR) modules (typically 40 channel), refer to Trusted TMR I/O SmartSlot Slot Cables, publication [ICSTT-RM313](#) (PD-TC500) and Trusted I/O Companion Slot Cables, publication [ICSTT-RM311](#) (PD-TC200).

PREFACE

In no event will Rockwell Automation be responsible or liable for indirect or consequential damages resulting from the use or application of this equipment. The examples given in this manual are included solely for illustrative purposes. Because of the many variables and requirements related to any particular installation, Rockwell Automation does not assume responsibility or reliability for actual use based on the examples and diagrams.

No patent liability is assumed by Rockwell Automation, with respect to use of information, circuits, equipment, or software described in this manual.

Allen-Bradley, LISTEN. THINK. SOLVE., Rockwell Automation, TechConnect, and Trusted are trademarks of Rockwell Automation, Inc.

All trademarks are acknowledged.

DISCLAIMER

It is not intended that the information in this publication covers every possible detail about the construction, operation, or maintenance of a control system installation. You should also refer to your own local (or supplied) system safety manual, installation and operator/maintenance manuals.

REVISION AND UPDATING POLICY

This document is based on information available at the time of its publication. The document contents are subject to change from time to time. The latest versions of the manuals are available at the Rockwell Automation Literature Library under "Product Information" information "Critical Process Control & Safety Systems".

TRUSTED RELEASE

This technical manual was updated for **Trusted Release 4.0**.

LATEST PRODUCT INFORMATION

For the latest information about this product review the Product Notifications and Technical Notes issued by technical support. Product Notifications and product support are available at the Rockwell Automation Support Centre at <http://rockwellautomation.custhelp.com>

At the Search Knowledgebase tab select the option "By Product" then scroll down and select the Trusted product.

Some of the Answer ID's in the Knowledge Base require a TechConnectSM Support Contract. For more information about TechConnect Support Contract Access Level and Features, click on the following link:

https://rockwellautomation.custhelp.com/app/answers/detail/a_id/50871

This will get you to the login page where you must enter your login details.

IMPORTANT A login is required to access the link. If you do not have an account then you can create one using the "Sign Up" link at the top right of the web page.

DOCUMENTATION FEEDBACK

Your comments help us to write better user documentation. If you discover an error, or have a suggestion on how to make this publication better, send your comment to our technical support group at <http://rockwellautomation.custhelp.com>

SCOPE

This manual specifies the maintenance requirements and describes the procedures to assist troubleshooting and maintenance of a Trusted system.

WHO SHOULD USE THIS MANUAL

This manual is for plant maintenance personnel who are experienced in the operation and maintenance of electronic equipment and are trained to work with safety systems.

SYMBOLS

In this manual we will use these notices to tell you about safety considerations.



SHOCK HAZARD: Identifies an electrical shock hazard. If a warning label is fitted, it can be on or inside the equipment.



WARNING: Identifies information about practices or circumstances that can cause an explosion in a hazardous environment, which can cause injury or death, property damage or economic loss.



ATTENTION: Identifies information about practices or circumstances that can cause injury or death.



CAUTION: Identifies information about practices or circumstances that can cause property damage or economic loss.



BURN HAZARD: Identifies where a surface can reach dangerous temperatures. If a warning label is fitted, it can be on or inside the equipment.



This symbol identifies items which must be thought about and put in place when designing and assembling a Trusted controller for use in a Safety Instrumented Function (SIF). It appears extensively in the Trusted Safety Manual.

IMPORTANT

Identifies information that is critical for successful application and understanding of the product.

NOTE

Provides key information about the product or service.

TIP

Tips give helpful information about using or setting up the equipment.

WARNINGS AND CAUTIONS

**WARNING: EXPLOSION RISK**

Do not connect or disconnect equipment while the circuit is live or unless the area is known to be free of ignitable concentrations or equivalent

**AVERTISSEMENT - RISQUE D'EXPLOSION**

Ne pas connecter ou déconnecter l'équipement alors qu'il est sous tension, sauf si l'environnement est exempt de concentrations inflammables ou équivalente

**MAINTENANCE**

Maintenance must be carried out only by qualified personnel. Failure to follow these instructions may result in personal injury.

**CAUTION: RADIO FREQUENCY INTERFERENCE**

Most electronic equipment is influenced by Radio Frequency Interference. Caution should be exercised with regard to the use of portable communications equipment around such equipment. Signs should be posted in the vicinity of the equipment cautioning against the use of portable communications equipment.

**CAUTION:**

The module PCBs contains static sensitive components. Static handling precautions must be observed. DO NOT touch exposed connector pins or attempt to dismantle a module.

ISSUE RECORD

Issue	Date	Comments
8	Sep 05	Format
9	Aug 06	Free wire idents
10	Dec 07	Flame retardance
11	Apr 16	Rebranded, reformatted and correction of typographical errors
12	Feb 19	Removed information about cables that are no longer offered. Added trademarks statement. Updated document display Rockwell Automation publication numbers.
13	May 19	Added information about -03 suffix (UL) cables.

Page intentionally left blank

Table of Contents

1.	Cable Selection Guides.....	3
2.	I/O Companion Slot Cable Type TC-701	5
3.	I/O Companion Slot Cable Type TC-702	7
4.	I/O Companion Slot Cable Type TC-704	9

Page intentionally left blank

1. Cable Selection Guides

INTERNAL	SMARTSLOT	INPUT	FTA	TC-501-
			VFTA	TC-511-
			Flying Lead	TC-502-
		OUTPUT	FTA	TC-505-
			VFTA	TC-509-
			Flying Lead	TC-506-
	COMPANION SLOT	INPUT	FTA	TC-201-
			VFTA	TC-211-
			Flying Lead	TC-202-
		OUTPUT	FTA	TC-205-
			VFTA	TC-209-
			Flying Lead	TC-206-
EXTERNAL	SMARTSLOT	INPUT	FTA	TC-503-
			VFTA	TC-512-
			Flying Lead	TC-504-
		OUTPUT	FTA	TC-507-
			VFTA	TC-510-
			Flying Lead	TC-508-
	COMPANION SLOT	INPUT	FTA	TC-203-
			VFTA	TC-212-
			Flying Lead	TC-204-
		OUTPUT	FTA	TC-207-
			VFTA	TC-210-
			Flying Lead	TC-208-
		Integral Power	Flying Lead	TC-218-

Table 2 TMR 40 Channel Standard Cable Selection Guide

INTERNAL	SMARTSLOT	INPUT	FTA	TC-601-
	COMPANION SLOT	INPUT	FTA	TC-701-

Table 3 Dual 60 Channel Standard Cable Selection Guide

The types of I/O Companion Slot Cables are described separately in the following sections.

2. I/O Companion Slot Cable Type TC-701

This type of cable, and the modules/FTAs it is used with, is shown in Figure 1 below.

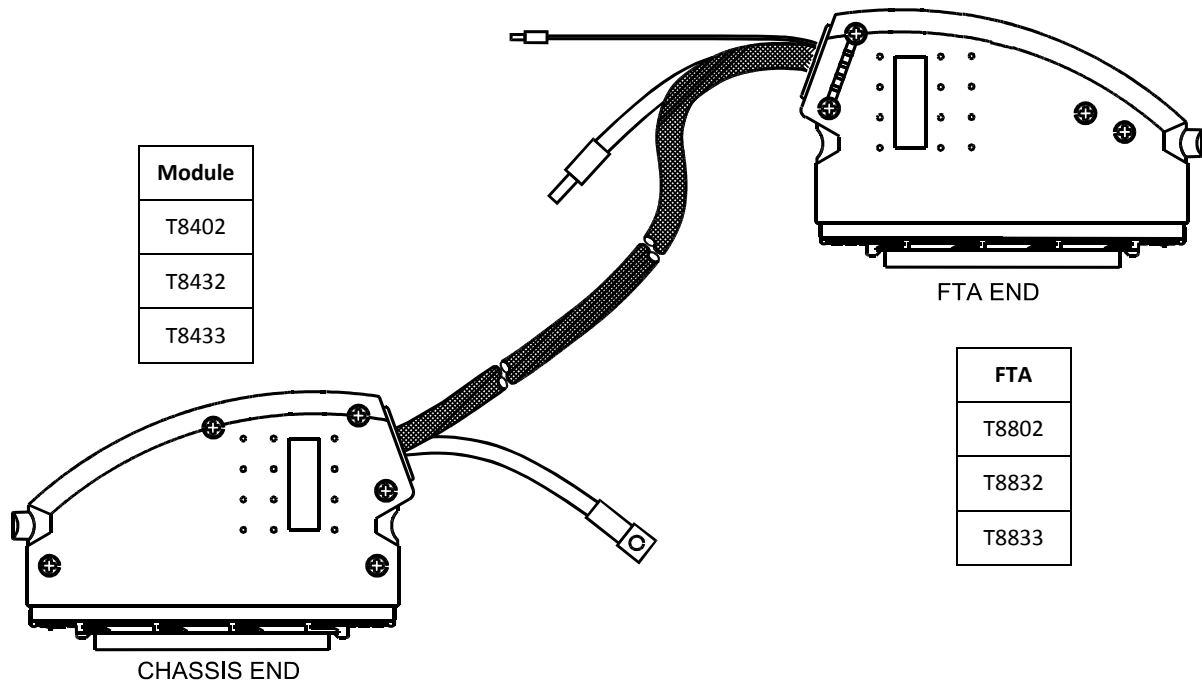

Figure 1 I/O Companion Slot Cable Type TC-701

This type of Trusted I/O Companion Slot Cable is designed for use with analogue or digital input modules and is suitable for connecting input signals from an internal FTA to the module.

The modules and FTAs are matched pairs for this cable:

- T8402 uses T8802
- T8432 uses T8832
- T8433 uses T8833 (non-standard connections on this module need the 60 channel cable).

The chassis end of the multi-core cable is fitted with a 96-way type 'C' connector housed in a double-width hood. The other end of the cable is fitted with a 96-way type 'R' connector housed in a single-width hood enabling the cable to be connected to an FTA.

The multi-core cable is stripped back 1.5 m at both ends, then shrouded in nylon Rilgain sheathing. The ends of the sheathing are heated or fitted with over sleeving to help prevent fraying.

At both the chassis and remote end, a sheathed braid allows the connector hood to be wired to safety earth. At the remote end, the multi-core screen drain is wired to a green wire to allow connection to screen earth.

3. I/O Companion Slot Cable Type TC-702

This type of cable, and the modules/FTAs it is used with, is shown in Figure 2 below.

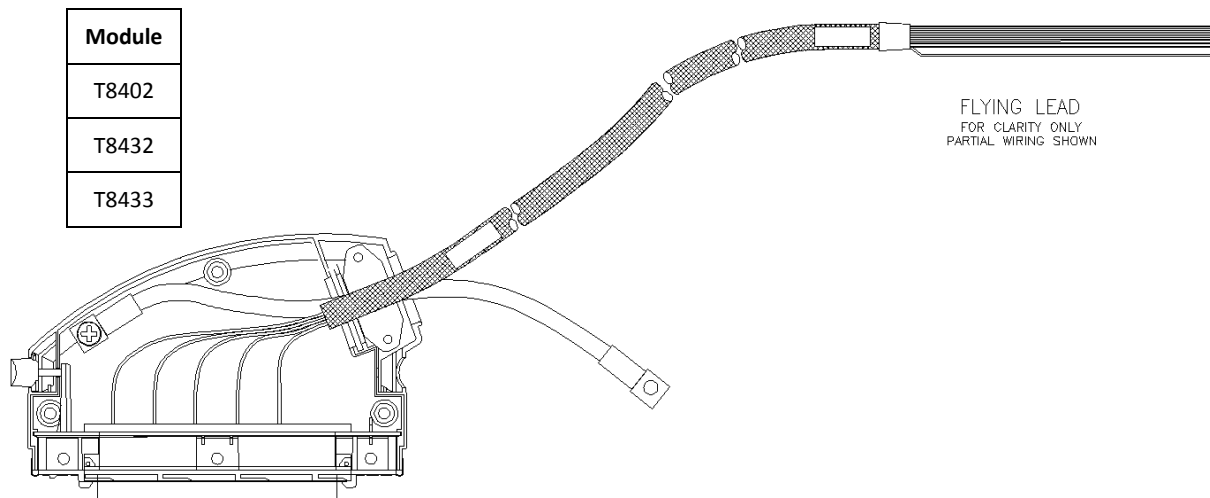

Figure 2 I/O Companion Slot Cable Type TC-702

This type of Trusted I/O Companion Slot Cable is designed for use with analogue or digital input modules and is suitable for connecting input signals from internal terminals to the module.

The chassis end of the multi-core cable is fitted with a 96-way type 'C' connector housed in a double-width hood. The other end of the cable is left as a 'flying lead' enabling the cable to be terminated as required, e.g. connected to conditioned field terminals.

The flying leads are sleeved with identity ferrules marked CH1, CH2, CH3 etc. for channel terminations or 0 V for group reference terminations.

The multi-core cable is stripped back 1.5 m at both ends, then shrouded in nylon Rilgain sheathing. The ends of the sheathing are heated or fitted with over sleeving to help prevent fraying.

At the chassis end, a sheathed braid allows the connector hood to be wired to safety earth. At the remote end, the multi core screen drain is wired to a green wire to allow connection to screen earth.

Page intentionally left blank

4. I/O Companion Slot Cable Type TC-704

This type of cable, and the modules/FTAs it is used with, is shown in Figure 3 below.

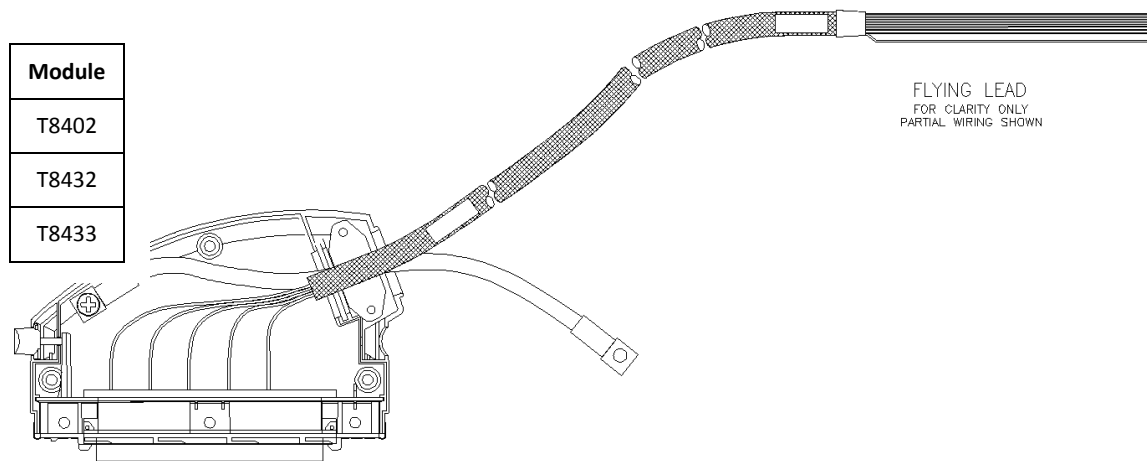

Figure 3 I/O Companion Slot Cable Type TC-704

This type of Trusted I/O Companion Slot Cable is designed for use with analogue or digital input modules and is suitable for connecting input signals from external terminals to the module.

The chassis end of the multi-core cable is fitted with a 96-way type 'C' connector housed in a double-width hood. The other end of the cable is left as a 'flying lead' enabling the cable to be terminated as required, e.g. connected to conditioned field terminals.

The flying leads are sleeved with identity ferrules marked CH1, CH2, CH3 etc. for channel terminations or 0 V for group reference terminations.

The multi-core cable is stripped back 1.5 m at both ends, then shrouded in nylon Rilgain sheathing. The ends of the sheathing are heated or fitted with over sleeving to help prevent fraying.

At the chassis end, a sheathed braid allows the connector hood to be wired to safety earth. At the remote end, the multi-core screen drain is wired to a green wire to allow connection to screen earth.