

# Trusted Speed Monitor Output FTA (SOFTA)

## Product Overview

The Trusted® Speed Monitor Output Field Termination Assembly (SOFTA) is a DIN rail mounted piece of equipment. It provides the output field interface for one rotating machine group when used as part of a Trusted T8442 Triple Modular Redundant (TMR) Speed Monitor system.

Both normally open and normally closed volt free contacts are available on the field terminals. This allows using the SOFTA in energized to trip and de-energized to trip configurations.

The two relay output channels are arranged as quad redundant, fault tolerant structures. Failure of any one relay or contact will not affect the load, or the ability to control the load.

Load current feedback to the T8442 Speed Monitor is provided for each switching path on each channel.

Force guided contact safety relays are used. These allow the T8442 Speed Monitor to detect welded or stuck output contacts via the contact status and load current feedback from the SOFTA.

Each relay, fuse and current-sensor can be replaced in situ.

## Features:

- Two online tested, fault tolerant, volt free contact output channels.
- Each output can be used as either a normally open or a normally closed contact.
- Fault tolerant quad redundant output relay structure.
- Load feedback monitoring.
- Contact status feedback.
- Force guided contact, safety relays.
- Standard DIN Rail mounting.
- Each output rated.
- Relays, fuses and current sensors can all be replaced in situ.



Page intentionally left blank

## PREFACE

In no event will Rockwell Automation be responsible or liable for indirect or consequential damages resulting from the use or application of this equipment. The examples given in this manual are included solely for illustrative purposes. Because of the many variables and requirements related to any particular installation, Rockwell Automation does not assume responsibility or reliability for actual use based on the examples and diagrams.

No patent liability is assumed by Rockwell Automation, with respect to use of information, circuits, equipment, or software described in this manual.

Allen-Bradley, LISTEN. THINK. SOLVE., Rockwell Automation, TechConnect, and Trusted are trademarks of Rockwell Automation, Inc.

All trademarks are acknowledged.

### DISCLAIMER

It is not intended that the information in this publication covers every possible detail about the construction, operation, or maintenance of a control system installation. You should also refer to your own local (or supplied) system safety manual, installation and operator/maintenance manuals.

### REVISION AND UPDATING POLICY

This document is based on information available at the time of its publication. The document contents are subject to change from time to time. The latest versions of the manuals are available at the Rockwell Automation Literature Library under "Product Information" information "Critical Process Control & Safety Systems".

### TRUSTED RELEASE

This technical manual was updated for **Trusted Release 4.0**.

### LATEST PRODUCT INFORMATION

For the latest information about this product review the Product Notifications and Technical Notes issued by technical support. Product Notifications and product support are available at the Rockwell Automation Support Centre at <http://rockwellautomation.custhelp.com>

At the Search Knowledgebase tab select the option "By Product" then scroll down and select the Trusted product.

Some of the Answer ID's in the Knowledge Base require a TechConnect<sup>SM</sup> Support Contract. For more information about TechConnect Support Contract Access Level and Features, click on the following link:

[https://rockwellautomation.custhelp.com/app/answers/detail/a\\_id/50871](https://rockwellautomation.custhelp.com/app/answers/detail/a_id/50871)

This will get you to the login page where you must enter your login details.

**IMPORTANT** A login is required to access the link. If you do not have an account then you can create one using the "Sign Up" link at the top right of the web page.

---

### DOCUMENTATION FEEDBACK

Your comments will help us serve your documentation needs better. If you have any suggestions on how to improve this document, complete the How Are We Doing? form at [http://literature.rockwellautomation.com/idc/groups/literature/documents/du/ra-du002\\_-en-e.pdf](http://literature.rockwellautomation.com/idc/groups/literature/documents/du/ra-du002_-en-e.pdf).

## SCOPE

This manual specifies the maintenance requirements and describes the procedures to assist troubleshooting and maintenance of a Trusted system.

## WHO SHOULD USE THIS MANUAL

This manual is for plant maintenance personnel who are experienced in the operation and maintenance of electronic equipment and are trained to work with safety systems.

## SYMBOLS

In this manual we will use these notices to tell you about safety considerations.



**SHOCK HAZARD:** Identifies an electrical shock hazard. If a warning label is fitted, it can be on or inside the equipment.



**WARNING:** Identifies information about practices or circumstances that can cause an explosion in a hazardous environment, which can cause injury or death, property damage or economic loss.



**ATTENTION:** Identifies information about practices or circumstances that can cause injury or death.



**CAUTION:** Identifies information about practices or circumstances that can cause property damage or economic loss.



**BURN HAZARD:** Identifies where a surface can reach dangerous temperatures. If a warning label is fitted, it can be on or inside the equipment.



This symbol identifies items which must be thought about and put in place when designing and assembling a Trusted controller for use in a Safety Instrumented Function (SIF). It appears extensively in the Trusted Safety Manual.

### IMPORTANT

Identifies information that is critical for successful application and understanding of the product.

### NOTE

Provides key information about the product or service.

### TIP

Tips give helpful information about using or setting up the equipment.

---

**WARNINGS AND CAUTIONS**

---

**WARNING: EXPLOSION RISK**

Do not connect or disconnect equipment while the circuit is live or unless the area is known to be free of ignitable concentrations or equivalent

---

**AVERTISSEMENT - RISQUE D'EXPLOSION**

Ne pas connecter ou déconnecter l'équipement alors qu'il est sous tension, sauf si l'environnement est exempt de concentrations inflammables ou équivalente

---

**MAINTENANCE**

Maintenance must be carried out only by qualified personnel. Failure to follow these instructions may result in personal injury.

---

**CAUTION: RADIO FREQUENCY INTERFERENCE**

Most electronic equipment is influenced by Radio Frequency Interference. Caution should be exercised with regard to the use of portable communications equipment around such equipment. Signs should be posted in the vicinity of the equipment cautioning against the use of portable communications equipment.

---

**CAUTION:**

The module PCBs contains static sensitive components. Static handling precautions must be observed. DO NOT touch exposed connector pins or attempt to dismantle a module.

---

ISSUE RECORD

Issue	Date	Comments
1	Sep 05	Photo added Table 2 Swapped Pins 16 & 17 descriptions
2	Mar 07	Corrections
3	Jun 16 (Not Published)	Rebranded and reformatted with correction of typographical errors. Also correction of statements for the Operating Temperature and Relative Humidity Range in the Specification Section. This issue was not published because of error in title.
4	Jul 16	Correction of error in title. "OFTA" changed to "Output FTA"
5	Jan 20	Section 3.2 and 3.3 – Changed Pins 1 & 2 to Normally-Open, and Pins 3 & 4 to Normally-Closed. These were incorrectly labeled as being Normally Closed and Normally Open, respectively. Section 4.2 – Updated Relay Contact Specifications table. Updated Documentation Feedback section. Updated document to display Rockwell Automation publication numbers. Added trademarks statement.

Page intentionally left blank



# Table of Contents

<b>1.</b>	<b>Product Range .....</b>	<b>3</b>
<b>2.</b>	<b>Assembly .....</b>	<b>5</b>
<b>3.</b>	<b>External Interfaces .....</b>	<b>7</b>
3.1.	Speed Monitor Interface (SK1).....	7
3.2.	Over-speed Trip - Field Output (SK2) .....	8
3.3.	Over-acceleration Trip - Field Output (SK3).....	8
<b>4.</b>	<b>Specifications.....</b>	<b>9</b>
4.1.	Relay Coil Input Specifications .....	9
4.2.	Relay Contact Specifications .....	10
4.3.	General Specifications.....	12
<b>5.</b>	<b>Dimensions .....</b>	<b>13</b>
<b>6.</b>	<b>Replaceable Component Location .....</b>	<b>15</b>

Page intentionally left blank

# 1. Product Range

Catalogue No.	Product name	Description
T8442	TMR Speed Monitor.	Trusted TMR Speed Monitor Module.
T8846	Speed Input FTA (SIFTA)	Input field termination assembly for use with the T8442 TMR Speed Monitor.
T8891	Speed Output FTA (SOFTA)	Output field termination assembly for use with the T8442 TMR Speed Monitor.
TC-801	I/O Companion Slot, Speed Monitor to FTA (Internal )	Companion Slot I/O cable with internal power, connects the T8442 to a single SIFTA and up to three SOFTAs.

**Table 1 T8442 TMR Speed Monitor Product Range**

Page intentionally left blank

## 2. Assembly

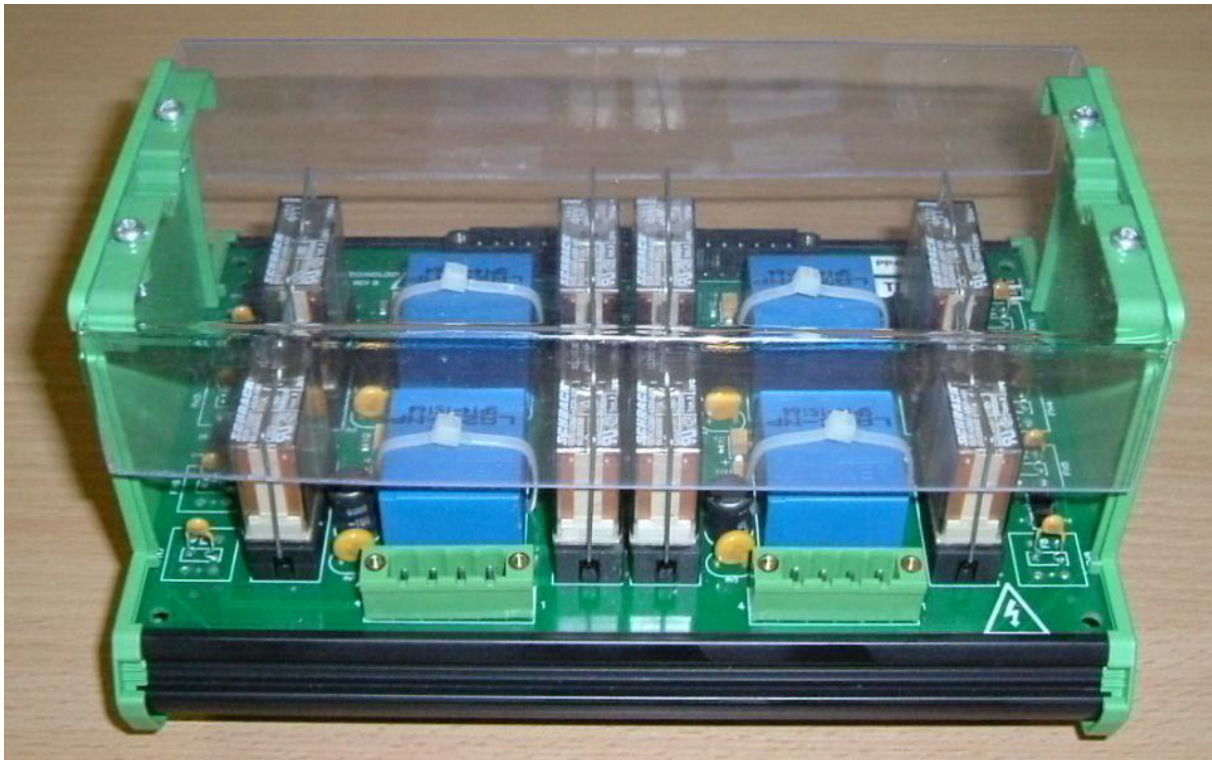

**Figure 1 Module Photograph**

A single Trusted T8442 TMR Speed Monitor interfaces with three T8891 SOFTA assemblies.

A single SOFTA assembly provides the relay switching elements for one over-speed output and one over-acceleration output.

For each output channel, an isolated Hall Effect current sensor is connected in series with each of the two parallel contact switching paths. The outputs from these sensors connect to the T8442 via the TC801 field interface cable and are used for relay contact diagnostic and fault detection purposes.

Force guided contact, safety relays are used on the SOFTA assembly. The physical properties of these relays verify that welded primary contacts can be detected by monitoring the auxiliary contact status signal. The contact status signal is passed back to the T8442 via the TC801 field interface cable for diagnostic and fault detection purposes.

The output contact can be used as a normally-open (de-energized relay) or a normally-closed (de-energized relay) contact for connection to the field load. They are electrically isolated from all other signals on the T8891 SOFTA and T8442 Speed Monitor.

**NOTE:** Recommended usage for relays:

- Normally open contacts: use for safety critical functions such as shutdown circuits

- Normally closed contacts: use for convenience functions such as indicators and buzzers.

Power, relay drive, current sense and contact status signals all interface directly to the T8442 via the TC801 field interface cable.

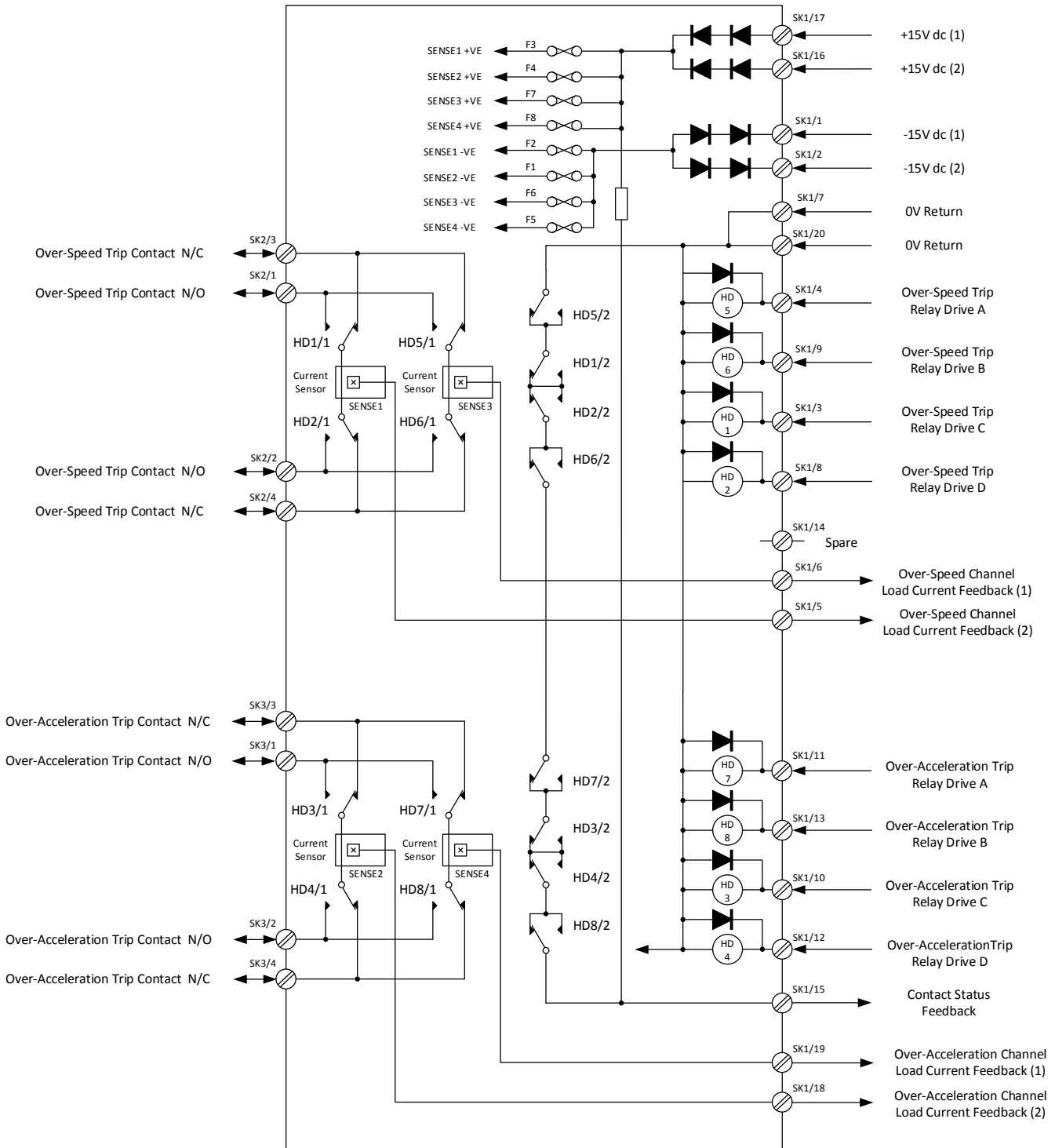

Figure 2 T8891 Overview

## 3. External Interfaces

The three external interfaces to the T8891 SOFTA are described in this section.

### 3.1. Speed Monitor Interface (SK1)

This provides the interface to the Trusted T8442 Speed Monitor. The connector mates directly with the Trusted TC-801 cable assembly.

Pin	Signal Name	Description
1	VFIELD_M15_1	-15V DC Power Supply Input (1)
2	VFIELD_M15_2	-15V DC Power Supply Input (2)
3	OVERSPEED_COIL_C	Over-speed Relay Coil Input (C)
4	OVERSPEED_COIL_A	Over-speed Relay Coil Input (A)
5	OVERSPEED_ISENSE_2	Over-speed Load Current Sensor Output (2)
6	OVERSPEED_ISENSE_1	Over-speed Load Current Sensor Output (1)
7	0V	0 V Power Supply Input
8	OVERSPEED_COIL_D	Over-speed Relay Coil Input (D)
9	OVERSPEED_COIL_B	Over-speed Relay Coil Input (B)
10	OVERACCELERATION_COIL_C	Over-acceleration Relay Coil Input (C)
11	OVERACCELERATION_COIL_A	Over-acceleration Relay Coil Input (A)
12	OVERACCELERATION_COIL_D	Over-acceleration Relay Coil Input (D)
13	OVERACCELERATION_COIL_B	Over-acceleration Relay Coil Input (B)
14	NOT CONNECTED	Spare
15	CONTACT_STATUS	Contact Status Output
16	VFIELD_P15_2	+15V DC Power Supply Input (2)
17	VFIELD_P15_1	+15V DC Power Supply Input (1)
18	OVERACCELERATION_ISENSE_2	Over-acceleration Load Current Sensor Output (2)
19	OVERACCELERATION_ISENSE_1	Over-acceleration Load Current Sensor Output (1)
20	0V	0 V Power Supply Input

**Table 2 T8442 Interface Connector (SK1)**

### 3.2. Over-speed Trip - Field Output (SK2)

This connector provides the volt free contact field connections for the over-speed trip output.

---

**Note:** Over-current protection for the field load must be provided externally.

---

Pin	Signal Name	Description
1	Over-speed Normally Open Contact A	Over-speed trip output Normally open contacts (shutdown state)
2	Over-speed Normally Open Contact B	
3	Over-speed Normally Closed Contact A	Over-speed trip output Normally closed contacts (shutdown state)
4	Over-speed Normally Closed Contact B	

**Table 3 Over-speed Trip Field Output Connector (SK2)**

### 3.3. Over-acceleration Trip - Field Output (SK3)

This connector provides the volt free contact field connections for the over-acceleration trip output.

---

**Note:** Over-current protection for the field load must be provided externally.

---

Pin	Signal Name	Description
1	Over-acceleration Normally Open Contact A	Over-acceleration trip output. Normally open contacts (shutdown state)
2	Over-acceleration Normally Open Contact B	
3	Over-acceleration Normally Closed Contact A	Over-acceleration trip output. Normally closed contacts (shutdown state)
4	Over-acceleration Normally Closed Contact B	

**Table 4 Over-acceleration Trip Field Output Connector (SK3)**



## 4. Specifications

### 4.1. Relay Coil Input Specifications

Parameter	Min	Type	Max	Unit	Note
Nominal voltage		24		V DC	
Pull-in voltage		18		V DC	
Release voltage		2.4		V DC	
Coil resistance	740		906	$\Omega$	
Coil current		29.2		mA	Coil voltage 24V DC
Nominal coil power		700		mW	

Table 5 Relay Coil Input Specifications

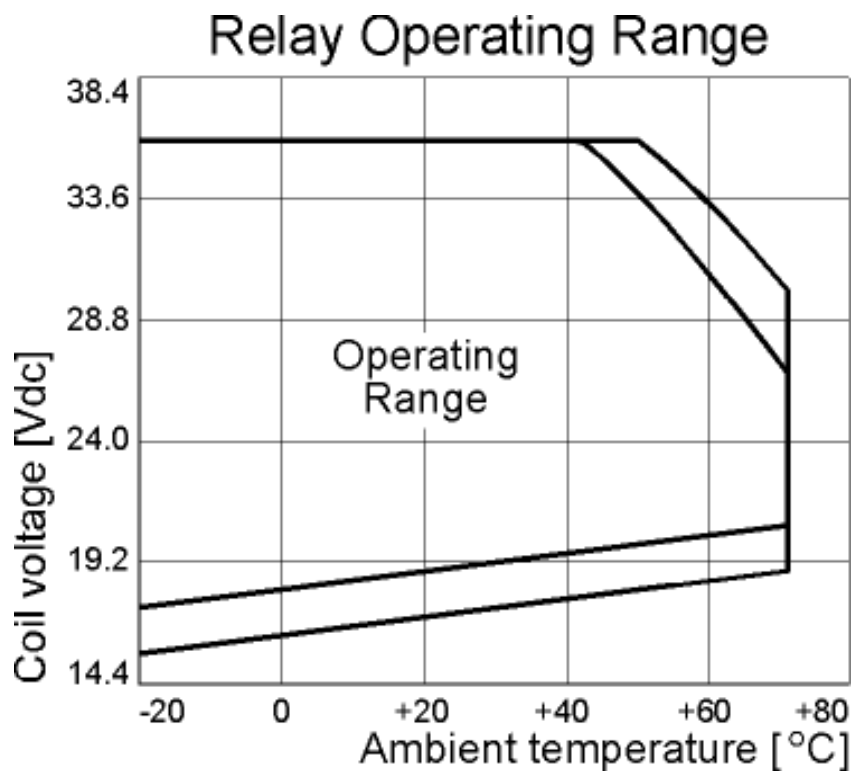

Figure 3 Relay Operating Range

## 4.2. Relay Contact Specifications

Type	Volt free	External protection required
Recommended External Fuse	Littelfuse PN: 021806.3TXP	Littelfuse

Operational Shock					
Parameter	Min	Typ	Max	Unit	Note
<b>General</b>					
Operational shock			15 <sup>(1)</sup>	g	11 ms burst
Operational vibration			1 <sup>(2)</sup>	g	8.4 to 150 Hz
<b>AC</b>					
Rated current	0.1		3	A	
Rated voltage	5	120	144	V AC	
Breaking capacity (resistive)			432	VA	
Endurance (electrical life)	100,000			Cycles	AC15 per IEC 60947-5-1 Annex C
Temporary overload	2 times maximum rated current				40 ms repeated once per second
<b>DC</b>					
Rated current	0.1		2	A	
Rated voltage	5	24	30	V DC	
Breaking capacity (resistive)			2	A	30V DC per UL 508
Endurance (electrical life)	100,000			Cycles	DC1 (L/R = 40 ms) per IEC 60947-4-1 Annex B
Temporary overload	2 times maximum rated current				40 ms repeated once per second

Note 1) Only 2g when contact is: NC de-energized.

Note 2) Only 0.3g when contact is: NC de-energized.

**Table 6 Relay Contact Specifications**

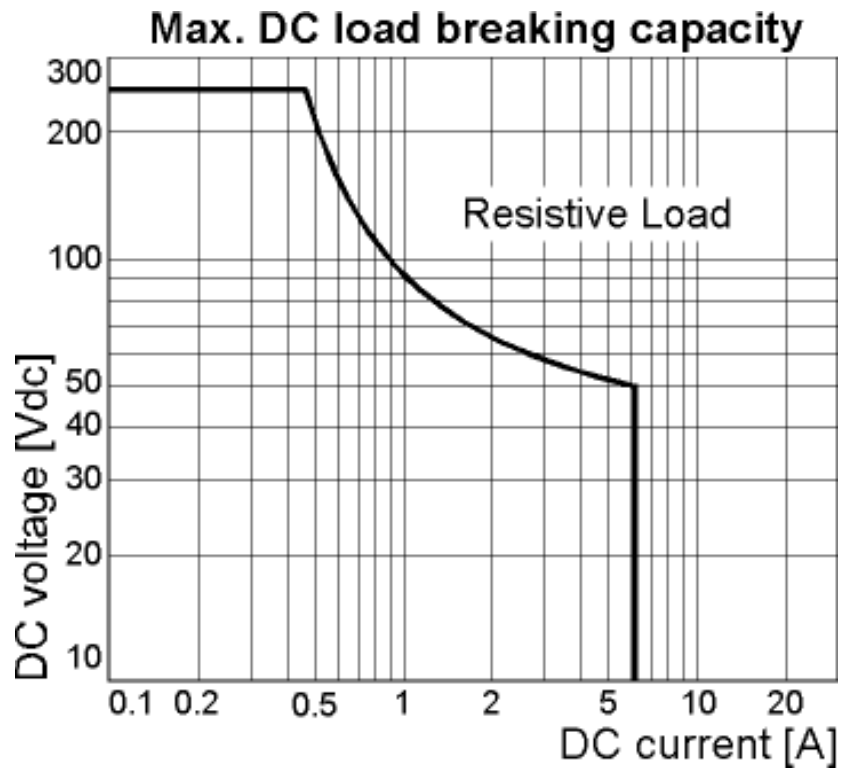

Figure 4 Relay Contact Maximum DC Load Breaking Capacity

### 4.3. General Specifications

Parameter	Min	Typ	Max	Unit	Note
<b>Field Common Insulation</b>					
Basic insulation	-250		250	V DC	
Maximum impulse withstand	-2500		2500	V DC	
<b>Temperature</b>					
Operating temperature	0		60	°C	
Storage temperature	-25		70	°C	
Temperature change			±0.5	°C/min	
Relative Humidity range (operating, storage & transport)	10		95	%	Non-Condensing
<b>Dimensions</b>					
Height		102 (4.0)		mm (in)	
Width		180 (7.10)		mm (in)	
Depth		127 (5.0)		mm (in)	
Weight		0.55 (1.2)		kg (lb)	

**Table 7 General Specifications**

## 5. Dimensions

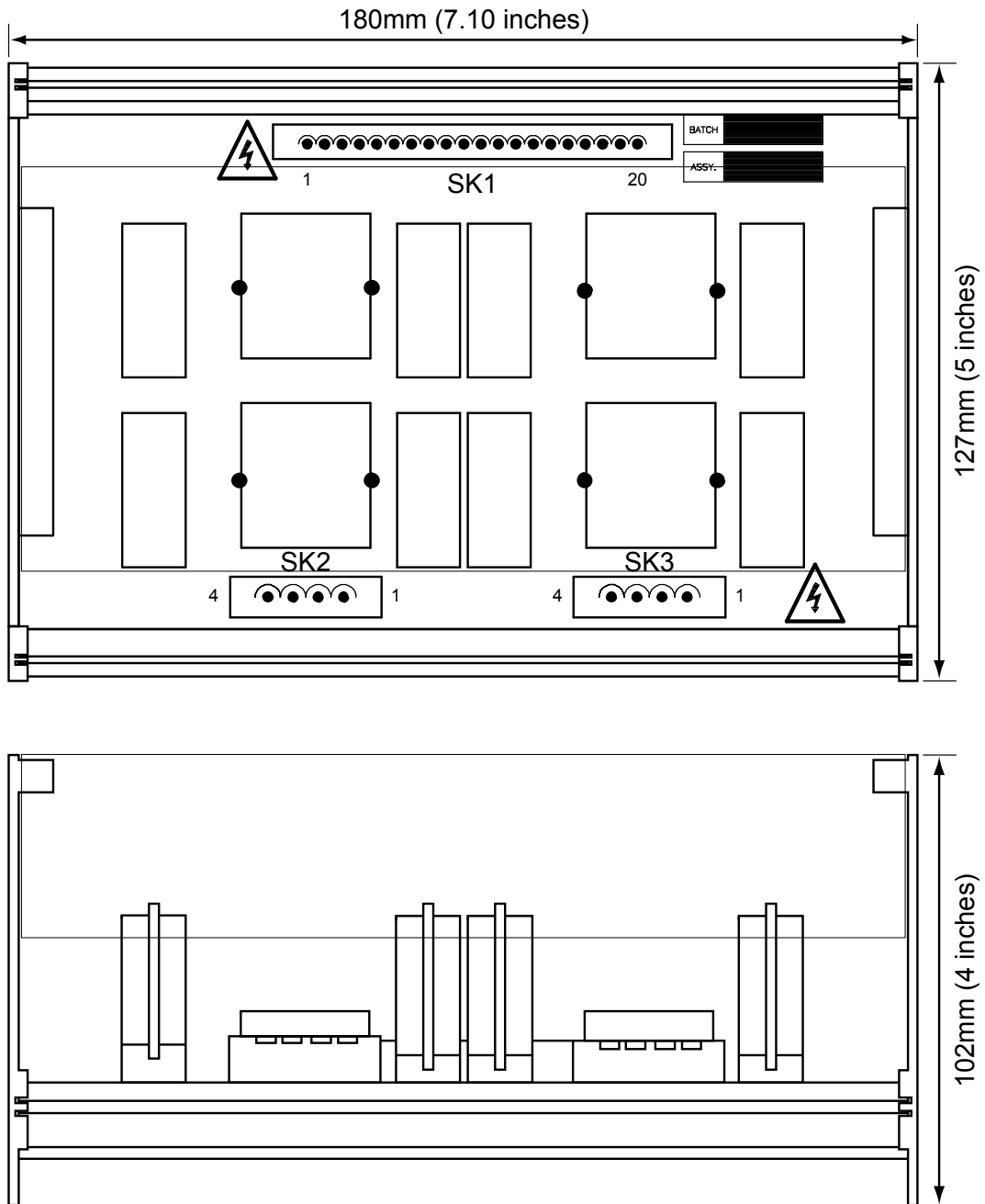

Figure 5 Dimensions

Page intentionally left blank

## 6. Replaceable Component Location

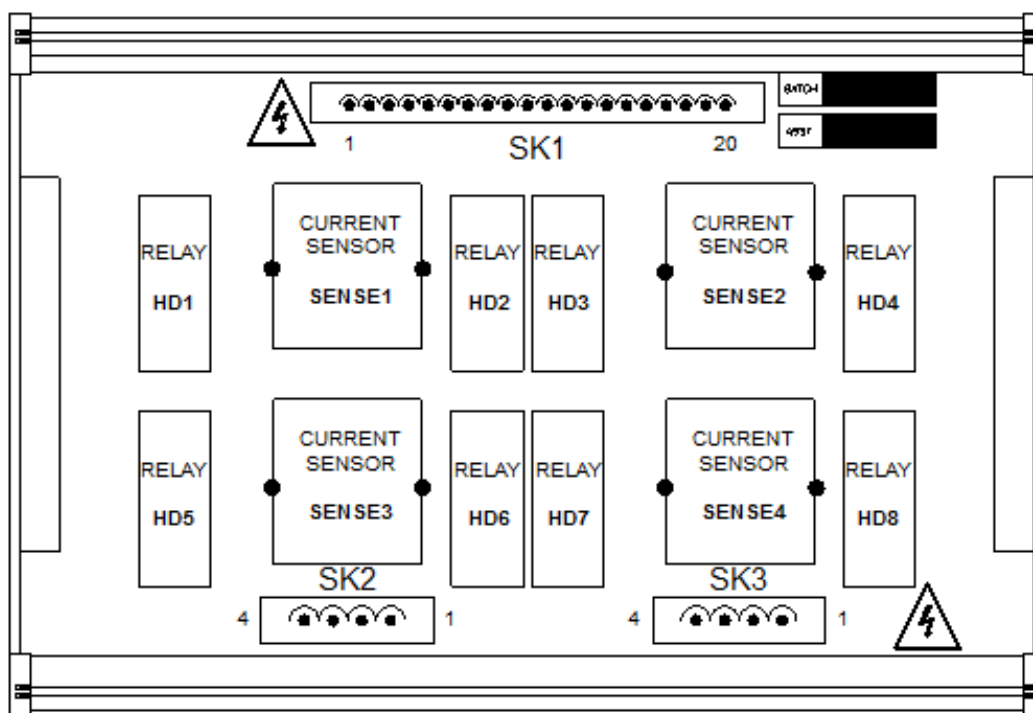

Figure 6 Replaceable Component Location

Component Ref	Description	Notes
Relay HD1	Over-speed relay	Over-speed output leg 2 (A)
Relay HD2	Over-speed relay	Over-speed output leg 2 (B)
Relay HD3	Over-acceleration relay	Over-acceleration output leg 2 (A)
Relay HD4	Over-acceleration relay	Over-acceleration output leg 2 (B)
Relay HD5	Over-speed relay	Over-speed output leg 1 (A)
Relay HD6	Over-speed relay	Over-speed output leg 1 (B)
Relay HD7	Over-acceleration relay	Over-acceleration output leg 1 (A)
Relay HD8	Over-acceleration relay	Over-acceleration output leg 1 (B)
Current sensor SENSE1	Load current sensor	Over-speed output leg 2
Current sensor SENSE2	Load current sensor	Over-acceleration output leg 2
Current sensor SENSE3	Load current sensor	Over-speed output leg 1
Current sensor SENSE4	Load current sensor	Over-acceleration output leg 2

Table 8 Replaceable Components