

# Trusted Speed Monitor Input FTA (SIFTA)

## Product Overview

The Trusted® Speed Monitor Input Field Termination Assembly (SIFTA) is a DIN rail assembly. It provides the input field interface for three rotating machine groups when used as part of a Trusted T8442 Triple Modular Redundant (TMR) Speed Monitor system.

## Features:

- Provides all necessary input interfaces for a Trusted T8442 TMR Speed Monitor.
- Nine speed input channels arranged as three groups of three inputs.
- Separate field power inputs for each of the three speed input groups.
- Field power and signal isolation between input groups.
- Versatile input connectivity allows interfacing with:
  - Active speed sensors with totem-pole outputs.
  - Active speed sensors with open-collector outputs.
  - Passive magnetic, inductive speed sensors.
- Standard DIN Rail mounting.
- All fuses can be replaced in situ.

Page intentionally left blank

## PREFACE

In no event will Rockwell Automation be responsible or liable for indirect or consequential damages resulting from the use or application of this equipment. The examples given in this manual are included solely for illustrative purposes. Because of the many variables and requirements related to any particular installation, Rockwell Automation does not assume responsibility or reliability for actual use based on the examples and diagrams.

No patent liability is assumed by Rockwell Automation, with respect to use of information, circuits, equipment, or software described in this manual.

Allen-Bradley, LISTEN. THINK. SOLVE., Rockwell Automation, TechConnect, and Trusted are trademarks of Rockwell Automation, Inc.

All trademarks are acknowledged.

### DISCLAIMER

It is not intended that the information in this publication covers every possible detail about the construction, operation, or maintenance of a control system installation. You should also refer to your own local (or supplied) system safety manual, installation and operator/maintenance manuals.

### REVISION AND UPDATING POLICY

This document is based on information available at the time of its publication. The document contents are subject to change from time to time. The latest versions of the manuals are available at the Rockwell Automation Literature Library under "Product Information" information "Critical Process Control & Safety Systems".

### TRUSTED RELEASE

This technical manual was updated for **Trusted Release 4.0**.

### LATEST PRODUCT INFORMATION

For the latest information about this product review the Product Notifications and Technical Notes issued by technical support. Product Notifications and product support are available at the Rockwell Automation Support Centre at <http://rockwellautomation.custhelp.com>

At the Search Knowledgebase tab select the option "By Product" then scroll down and select the Trusted product.

Some of the Answer ID's in the Knowledge Base require a TechConnect<sup>SM</sup> Support Contract. For more information about TechConnect Support Contract Access Level and Features, click on the following link:

[https://rockwellautomation.custhelp.com/app/answers/detail/a\\_id/50871](https://rockwellautomation.custhelp.com/app/answers/detail/a_id/50871)

This will get you to the login page where you must enter your login details.

**IMPORTANT** A login is required to access the link. If you do not have an account then you can create one using the "Sign Up" link at the top right of the web page.

---

## DOCUMENTATION FEEDBACK

Your comments will help us serve your documentation needs better. If you have any suggestions on how to improve this document, complete the How Are We Doing? form at [http://literature.rockwellautomation.com/idc/groups/literature/documents/du/ra-du002\\_-en-e.pdf](http://literature.rockwellautomation.com/idc/groups/literature/documents/du/ra-du002_-en-e.pdf).

## SCOPE

This manual specifies the maintenance requirements and describes the procedures to assist troubleshooting and maintenance of a Trusted system.

## WHO SHOULD USE THIS MANUAL

This manual is for plant maintenance personnel who are experienced in the operation and maintenance of electronic equipment and are trained to work with safety systems.

## SYMBOLS

In this manual we will use these notices to tell you about safety considerations.



**SHOCK HAZARD:** Identifies an electrical shock hazard. If a warning label is fitted, it can be on or inside the equipment.



**WARNING:** Identifies information about practices or circumstances that can cause an explosion in a hazardous environment, which can cause injury or death, property damage or economic loss.



**ATTENTION:** Identifies information about practices or circumstances that can cause injury or death.



**CAUTION:** Identifies information about practices or circumstances that can cause property damage or economic loss.



**BURN HAZARD:** Identifies where a surface can reach dangerous temperatures. If a warning label is fitted, it can be on or inside the equipment.



This symbol identifies items which must be thought about and put in place when designing and assembling a Trusted controller for use in a Safety Instrumented Function (SIF). It appears extensively in the Trusted Safety Manual.

### IMPORTANT

Identifies information that is critical for successful application and understanding of the product.

### NOTE

Provides key information about the product or service.

### TIP

Tips give helpful information about using or setting up the equipment.

---

**WARNINGS AND CAUTIONS**

---

**WARNING: EXPLOSION RISK**

Do not connect or disconnect equipment while the circuit is live or unless the area is known to be free of ignitable concentrations or equivalent

---

**AVERTISSEMENT - RISQUE D'EXPLOSION**

Ne pas connecter ou déconnecter l'équipement alors qu'il est sous tension, sauf si l'environnement est exempt de concentrations inflammables ou équivalente

---

**MAINTENANCE**

Maintenance must be carried out only by qualified personnel. Failure to follow these instructions may result in personal injury.

---

**CAUTION: RADIO FREQUENCY INTERFERENCE**

Most electronic equipment is influenced by Radio Frequency Interference. Caution should be exercised with regard to the use of portable communications equipment around such equipment. Signs should be posted in the vicinity of the equipment cautioning against the use of portable communications equipment.

---

**CAUTION:**

The module PCBs contains static sensitive components. Static handling precautions must be observed. **DO NOT** touch exposed connector pins or attempt to dismantle a module.

---

ISSUE RECORD

Issue	Date	Comments
1	Sept 05	Format
2	Apr 10	Corrections to termination pin numbers
3	June 16	Rebranded and updated to incorporate IEEE standards with correction of typographical errors and also standardise the Relative Humidity Range and Operating Temperature statements in the Specification Section.
4	Jun 17	Figure 5 “Active Totem Pole Output Sensor (Externally Derived Field Supply)” amended
5	Jan 20	Updated Specifications table. Updated Documentation Feedback section. Updated document to display Rockwell Automation publication numbers. Added trademarks statement.

Page intentionally left blank



---

# Table of Contents

<b>1.</b>	<b>Product Range .....</b>	<b>1</b>
<b>2.</b>	<b>Assembly .....</b>	<b>3</b>
<b>3.</b>	<b>External Interfaces .....</b>	<b>5</b>
3.1.	Field Power Inputs.....	5
3.2.	Speed Monitor Interfaces .....	7
3.3.	Speed Inputs.....	10
<b>4.</b>	<b>Field Connection Arrangements .....</b>	<b>14</b>
4.1.	Active Totem Pole Output Sensor Types.....	14
4.1.1.	Sensor Power Derived from FTA .....	14
4.1.2.	Sensor Power Derived Externally .....	15
4.2.	Active Open Collector Output Sensor Types.....	16
4.2.1.	Sensor Power Derived From FTA.....	16
4.2.2.	Sensor Power Derived Externally .....	17
4.3.	Passive Output Sensor Types .....	18
4.4.	Chassis Ground Connections.....	18
<b>5.</b>	<b>Specifications.....</b>	<b>20</b>
5.1.	Group Vfield Power Supply Input Specifications .....	20
5.2.	Group Speed Input Specifications.....	20
5.3.	General Specifications.....	21

Page intentionally left blank

# 1. Product Range

Catalogue No.	Product name	Description
T8442	TMR Speed Monitor.	Trusted TMR Speed Monitor Module.
T8846	Speed Input FTA (SIFTA)	Input field termination assembly for use with the T8442 TMR Speed Monitor.
T8891	Speed Output FTA (SOFTA)	Output field termination assembly for use with the T8442 TMR Speed Monitor.
TC-801	I/O Companion Slot, Speed Monitor to FTA (Internal )	Companion Slot Input/Output (I/O) cable with internal power. This connects an active/standby hot swap pair of T8442 modules to a single SIFTA and up to three SOFTAs.

**Table 1 T8442 TMR Speed Monitor Product Range**

Page intentionally left blank

## 2. Assembly



**Figure 1 T8846 Module Photo**

The T8846 Speed Input Field Termination Assembly (SIFTA) is an integral part of the overall T8442 Speed monitor system. It is DIN rail mounted, containing passive signal conditioning, power distribution and protection components.

Each T8442 Speed Monitor Module hot swap pair requires a single T8846 SIFTA when installed in a Trusted system.

The SIFTA has nine identical speed transducer signal conditioning circuits arranged as three groups of three.

Each of the three groups is a galvanically isolated entity, with its own field power and I/O signal interfaces.

Multiple sensors must be employed for SIL 3 applications.

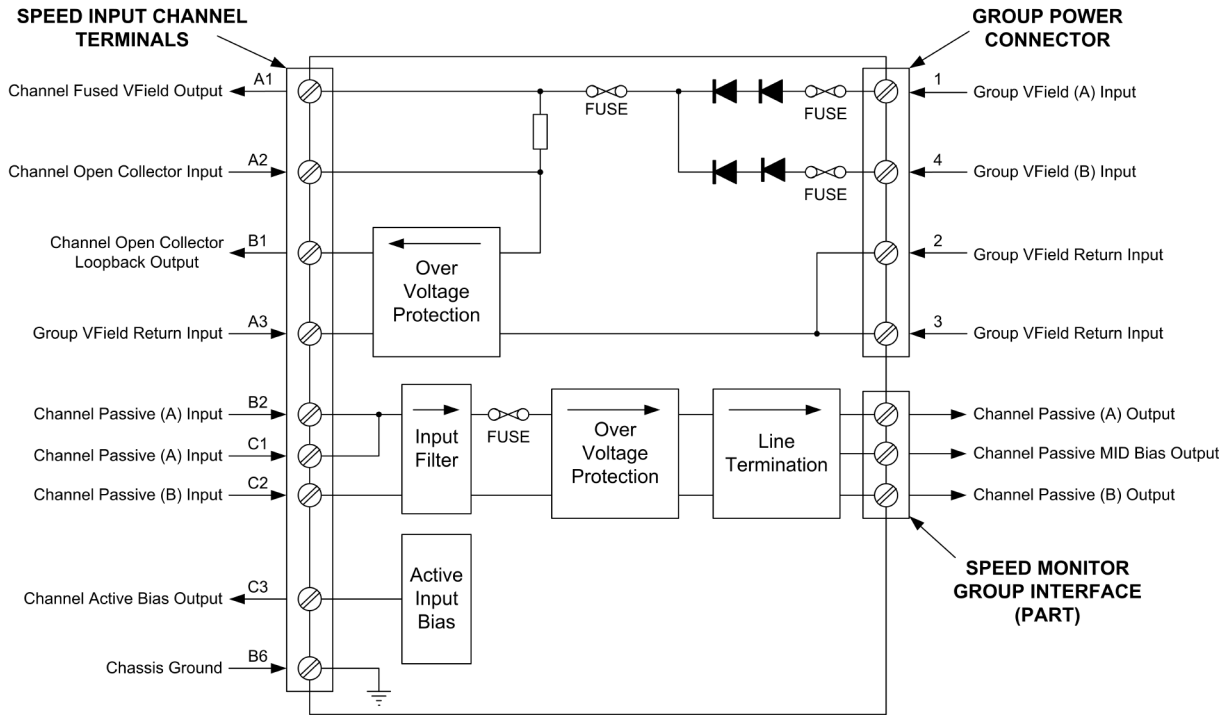

Figure 2 T8846 Speed Input Channel Overview

### 3. External Interfaces

Figure 3 shows the T8846 general assembly.

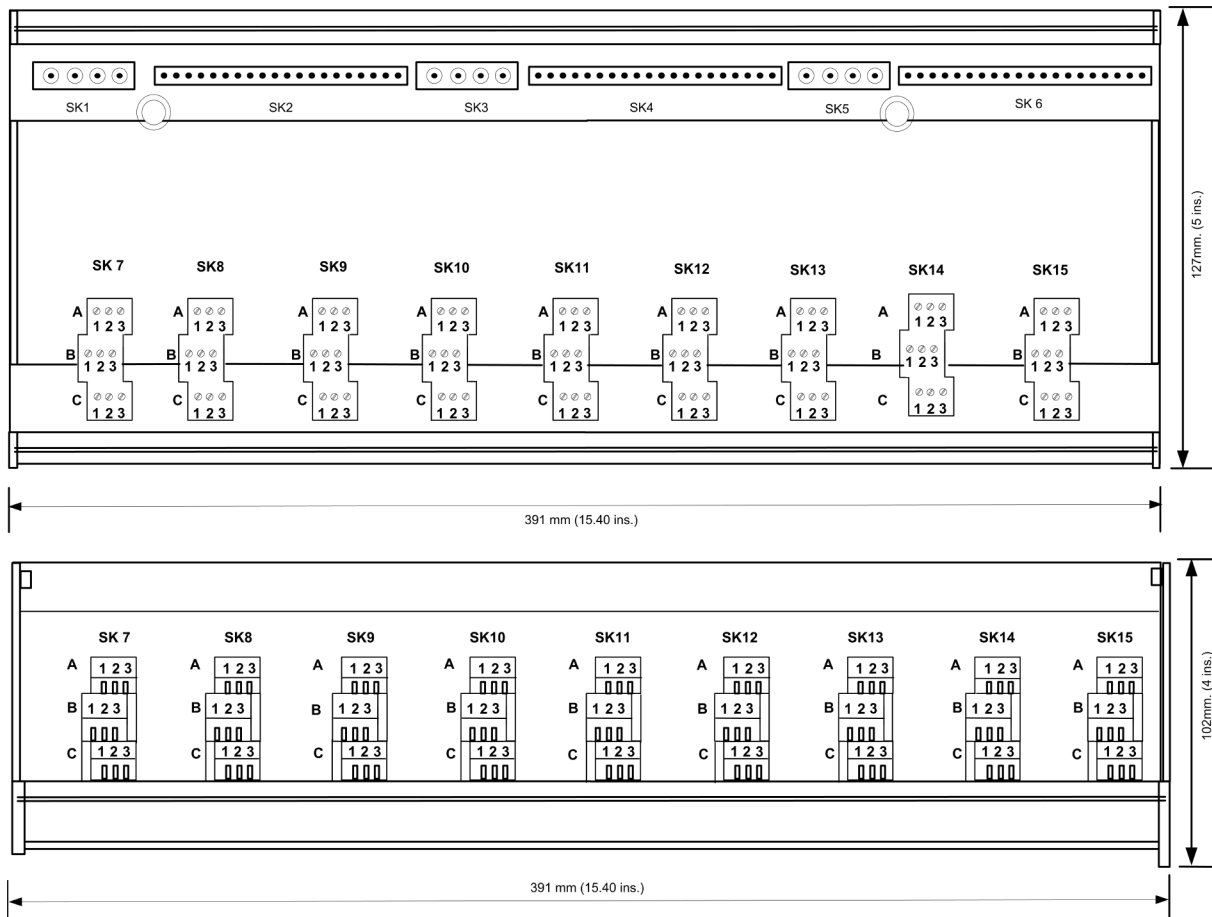

Figure 3 T8846 General Assembly – Top View and Front View

#### 3.1. Field Power Inputs

This section details the field power input connections for each speed monitor input group.

There are three 4-way connectors on the FTA which provide the field power interface to the FTA. Each connector is dedicated to one speed input group.

Refer to Figure 3 for the location of the interface sockets.

Interface	Pin	Signal Name	Description
SK1	A1	Group 1 Vfield A Input	+24 Vdc (A) Dual redundant power supply input for group 1 speed inputs.
SK1	A2	Group 1 Vfield Return Input	0 V Vfield Power supply return for group 1 speed inputs.
SK1	A3	Group 1 Vfield Return Input	
SK1	B1	Group 1 Vfield B Input	+24 Vdc (B) Dual redundant power supply input for group 1 speed inputs.
SK3	A1	Group 2 Vfield A Input	+24 Vdc (A) Dual redundant power supply input for group 2 speed inputs.
SK3	A2	Group 2 Vfield Return Input	0 V Vfield Power supply return for group 2 speed inputs.
SK3	A3	Group 2 Vfield Return Input	
SK3	B1	Group 2 Vfield B Input	+24 Vdc (B) Dual redundant power supply input for group 2 speed inputs.
SK5	A1	Group 3 Vfield A Input	+24 Vdc (A) Dual redundant power supply input for group 3 speed inputs.
SK5	A2	Group 3 Vfield Return Input	0 V Vfield Power supply return for group 3 speed inputs.
SK5	A3	Group 3 Vfield Return Input	
SK5	B1	Group 3 Vfield B Input	+24 Vdc (B) Dual redundant power supply input for group 3 speed inputs.

**Table 2 - Field Power Input Connections**



### 3.2. Speed Monitor Interfaces

This section details the interfaces between the T8846 SIFTA and the Trusted T8442 Speed Monitor.

There are three 20-way connectors on the FTA which provide the interface to the Trusted T8442 Speed Monitor. Each connector is dedicated to one speed input group and mates directly with the Trusted TC-801 cable assembly.

Refer to Figure 3 for the location of the connectors.

Interface	Pin	Description
SK2	1	Group 1 Vfield (A) fused output
SK2	2	Group 1 Vfield (B) fused output
SK2	3	Not Connected
SK2	4	Group 1 Channel 1 MID Bias
SK2	5	Group 1 Channel 1 Passive (A) output
SK2	6	Group 1 0 V (ground)
SK2	7	Group 1 Channel 1 Passive (B) output
SK2	8	Chassis Ground
SK2	9	Not Connected
SK2	10	Group 1 Channel 2 MID Bias
SK2	11	Group 1 Channel 2 Passive (A) output
SK2	12	Group 1 0 V (ground)
SK2	13	Group 1 Channel 2 Passive (B) output
SK2	14	Chassis Ground
SK2	15	Not Connected
SK2	16	Group 1 Channel 3 MID Bias
SK2	17	Group 1 Channel 3 Passive (A) output

Interface	Pin	Description
SK2	18	Group 1 0 V (ground)
SK2	19	Group 1 Channel 3 Passive (B) output
SK2	20	Chassis Ground

Table 3 Speed Monitor Interface Group 1

Interface	Pin	Description
SK4	1	Group 2 Vfield (A) fused output
SK4	2	Group 2 Vfield (B) fused output
SK4	3	Not Connected
SK4	4	Group 2 Channel 1 MID Bias
SK4	5	Group 2 Channel 1 Passive (A) output
SK4	6	Group 2 0 V (ground)
SK4	7	Group 2 Channel 1 Passive (B) output
SK4	8	Chassis Ground
SK4	9	Not Connected
SK4	10	Group 2 Channel 2 MID Bias
SK4	11	Group 2 Channel 2 Passive (A) output
SK4	12	Group 2 0 V (ground)
SK4	13	Group 2 Channel 2 Passive (B) output
SK4	14	Chassis Ground
SK4	15	Not Connected
SK4	16	Group 2 Channel 3 MID Bias
SK4	17	Group 2 Channel 3 Passive (A) output

Interface	Pin	Description
SK4	18	Group 2 0 V (ground)
SK4	19	Group 2 Channel 3 Passive (B) output
SK4	20	Chassis Ground

Table 4 Speed Monitor Interface Group 2

Interface	Pin	Description
SK6	1	Group 3 Vfield (A) fused output
SK6	2	Group 3 Vfield (B) fused output
SK6	3	Not Connected
SK6	4	Group 3 Channel 1 MID Bias
SK6	5	Group 3 Channel 1 Passive (A) output
SK6	6	Group 3 0 V (ground)
SK6	7	Group 3 Channel 1 Passive (B) output
SK6	8	Chassis Ground
SK6	9	Not Connected
SK6	10	Group 3 Channel 2 MID Bias
SK6	11	Group 3 Channel 2 Passive (A) output
SK6	12	Group 3 0 V (ground)
SK6	13	Group 3 Channel 2 Passive (B) output
SK6	14	Chassis Ground
SK6	15	Not Connected
SK6	16	Group 3 Channel 3 MID Bias
SK6	17	Group 3 Channel 3 Passive (A) output

Interface	Pin	Description
SK6	18	Group 3 0 V (ground)
SK6	19	Group 3 Channel 3 Passive (B) output
SK6	20	Chassis Ground

Table 5 Speed Monitor Interface Group 3

### 3.3. Speed Inputs

This section details the speed input terminal connections. These terminals are used to interface to the field sensor input cables.

Refer to Figure 3 for the location of the interface terminals.

Interface	Terminal	Description
SK7	A1	Group 1 Channel 1 Fused Vfield Output
SK7	A2	Group 1 Channel 1 Open Collector Input
SK7	A3	Group 1 0 V (Ground)
SK7	B1	Group 1 Channel 1 Open Collector Loopback
SK7	B2	Group 1 Channel 1 Passive A Input (a duplicate input is also available on SK7 terminal 7)
SK7	B3	Chassis Ground
SK7	C1	Group 1 Channel 1 Passive A Input (a duplicate of SK7 terminal 5)
SK7	C2	Group 1 Channel 1 Passive B Input
SK7	C3	Group 1 Channel 1 Active Bias Output
SK8	A1	Group 1 Channel 2 Fused Vfield Output
SK8	A2	Group 1 Channel 2 Open Collector Input
SK8	A3	Group 1 0 V (Ground)
SK8	B1	Group 1 Channel 2 Open Collector Loopback
SK8	B2	Group 1 Channel 2 Passive A Input (a duplicate input is also available on SK8 terminal 7)

Interface	Terminal	Description
SK8	B3	Chassis Ground
SK8	C1	Group 1 Channel 2 Passive A Input (a duplicate of SK8 terminal 5)
SK8	C2	Group 1 Channel 2 Passive B Input
SK8	C3	Group 1 Channel 2 Active Input Bias
SK9	A1	Group 1 Channel 3 Fused Vfield Output
SK9	A2	Group 1 Channel 3 Open Collector Input
SK9	A3	Group 1 0 V (Ground)
SK9	B1	Group 1 Channel 3 Open Collector Loopback
SK9	B2	Group 1 Channel 3 Passive A Input (a duplicate input is also available on SK9 terminal 7)
SK9	B3	Chassis Ground
SK9	C1	Group 1 Channel 3 Passive A Input (a duplicate of SK9 terminal 5)
SK9	C2	Group 1 Channel 3 Passive B Input
SK9	C3	Group 1 Channel 3 Active Input Bias
SK10	A1	Group 2 Channel 1 Fused Vfield Output
SK10	A2	Group 2 Channel 1 Open Collector Input
SK10	A3	Group 2 0 V (Ground)
SK10	B1	Group 2 Channel 1 Open Collector Loopback
SK10	B2	Group 2 Channel 1 Passive A Input (a duplicate input is also available on SK10 terminal 7)
SK10	B3	Chassis Ground
SK10	C1	Group 2 Channel 1 Passive A Input (a duplicate of SK10 terminal 5)
SK10	C2	Group 2 Channel 1 Passive B Input
SK10	C3	Group 2 Channel 1 Active Input Bias
SK11	A1	Group 2 Channel 2 Fused Vfield Output

Interface	Terminal	Description
SK11	A2	Group 2 Channel 2 Open Collector Input
SK11	A3	Group 2 0 V (Ground)
SK11	B1	Group 2 Channel 2 Open Collector Loopback
SK11	B2	Group 2 Channel 2 Passive A Input (a duplicate input is also available on SK11 terminal 7)
SK11	B3	Chassis Ground
SK11	C1	Group 2 Channel 2 Passive A Input (a duplicate of SK11 terminal 5)
SK11	C2	Group 2 Channel 2 Passive B Input
SK11	C3	Group 2 Channel 2 Active Input Bias
SK12	A1	Group 2 Channel 3 Fused Vfield Output
SK12	A2	Group 2 Channel 3 Open Collector Input
SK12	A3	Group 2 0 V (Ground)
SK12	B1	Group 2 Channel 3 Open Collector Loopback
SK12	B2	Group 2 Channel 3 Passive A Input (a duplicate input is also available on SK12 terminal 7)
SK12	B3	Chassis Ground
SK12	C1	Group 2 Channel 3 Passive A Input (a duplicate of SK12 terminal 5)
SK12	C2	Group 2 Channel 3 Passive B Input
SK12	C3	Group 2 Channel 3 Active Input Bias
SK13	A1	Group 3 Channel 1 Fused Vfield Output
SK13	A2	Group 3 Channel 1 Open Collector Input
SK13	A3	Group 3 0 V (Ground)
SK13	B1	Group 3 Channel 1 Open Collector Loopback
SK13	B2	Group 3 Channel 1 Passive A Input (a duplicate input is also available on SK13 terminal 7)
SK13	B3	Chassis Ground

Interface	Terminal	Description
SK13	C1	Group 3 Channel 1 Passive A Input (a duplicate of SK13 terminal 5)
SK13	C2	Group 3 Channel 1 Passive B Input
SK13	C3	Group 3 Channel 1 Active Input Bias
SK14	A1	Group 3 Channel 2 Fused Vfield Output
SK14	A2	Group 3 Channel 2 Open Collector Input
SK14	A3	Group 3 0 V (Ground)
SK14	B1	Group 3 Channel 2 Open Collector Loopback
SK14	B2	Group 3 Channel 2 Passive A Input (a duplicate input is also available on SK14 terminal 7)
SK14	B3	Chassis Ground
SK14	C1	Group 3 Channel 2 Passive A Input (a duplicate of SK14 terminal 5)
SK14	C2	Group 3 Channel 2 Passive B Input
SK14	C3	Group 3 Channel 2 Active Input Bias
SK15	A1	Group 3 Channel 3 Fused Vfield Output
SK15	A2	Group 3 Channel 3 Open Collector Input
SK15	A3	Group 3 0 V (Ground)
SK15	B1	Group 3 Channel 3 Open Collector Loopback
SK15	B2	Group 3 Channel 3 Passive A Input (a duplicate input is also available on SK15 terminal 7)
SK15	B3	Chassis Ground
SK15	C1	Group 3 Channel 3 Passive A Input (a duplicate of SK15 terminal 5)
SK15	C2	Group 3 Channel 3 Passive B Input
SK15	C3	Group 3 Channel 3 Active Input Bias

Table 6 Speed Input Connections

## 4. Field Connection Arrangements

This section shows the speed input connection arrangements for typical sensor configurations.

Active sensors are considered as field powered devices, and are available in two principal varieties:

- Totem Pole output sensors, actively drive their outputs to a positive potential and to ground and do not rely on an external voltage bias.
- Open Collector output sensors, can only actively drive their outputs to ground and rely on an external pull-up resistor to bias the output to a positive potential. The T8846 SIFTA provides the biasing components for this type of sensor.

Passive sensors are considered to be magnetic, inductive pick up devices with no field power requirements.

### 4.1. Active Totem Pole Output Sensor Types

#### 4.1.1. Sensor Power Derived from FTA

Figure 4 shows a typical field connection scheme for +24 Vdc field powered speed sensors with totem pole outputs. This arrangement uses the fused field supply derived from the FTA.

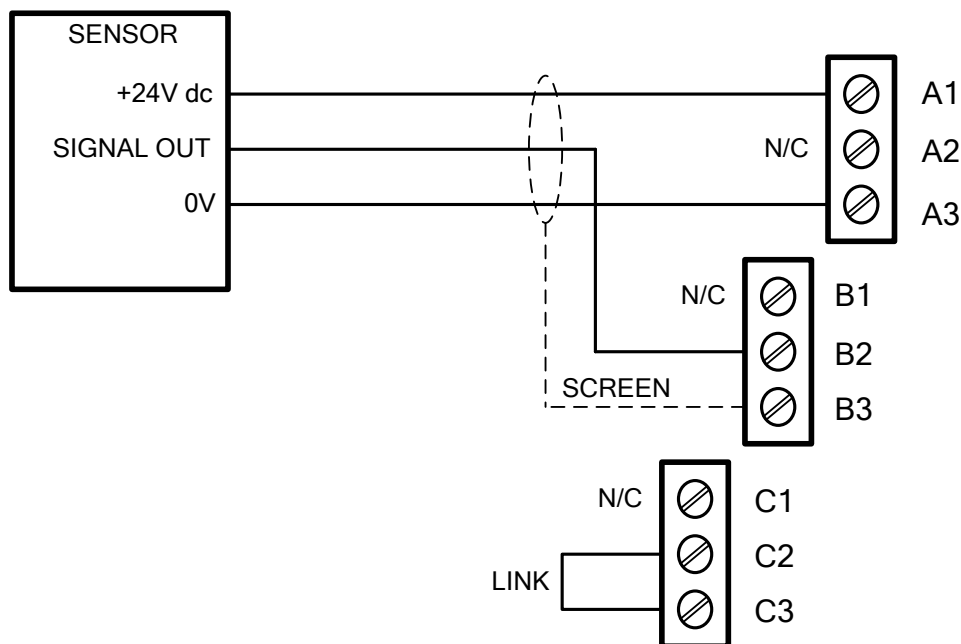

Figure 4 Active Totem Pole Output Sensor Connections (FTA Derived Field Supply)



### 4.1.2. Sensor Power Derived Externally

Figure 5 shows a typical field connection scheme for field powered speed sensors with totem pole outputs. This arrangement uses an external fused field supply.

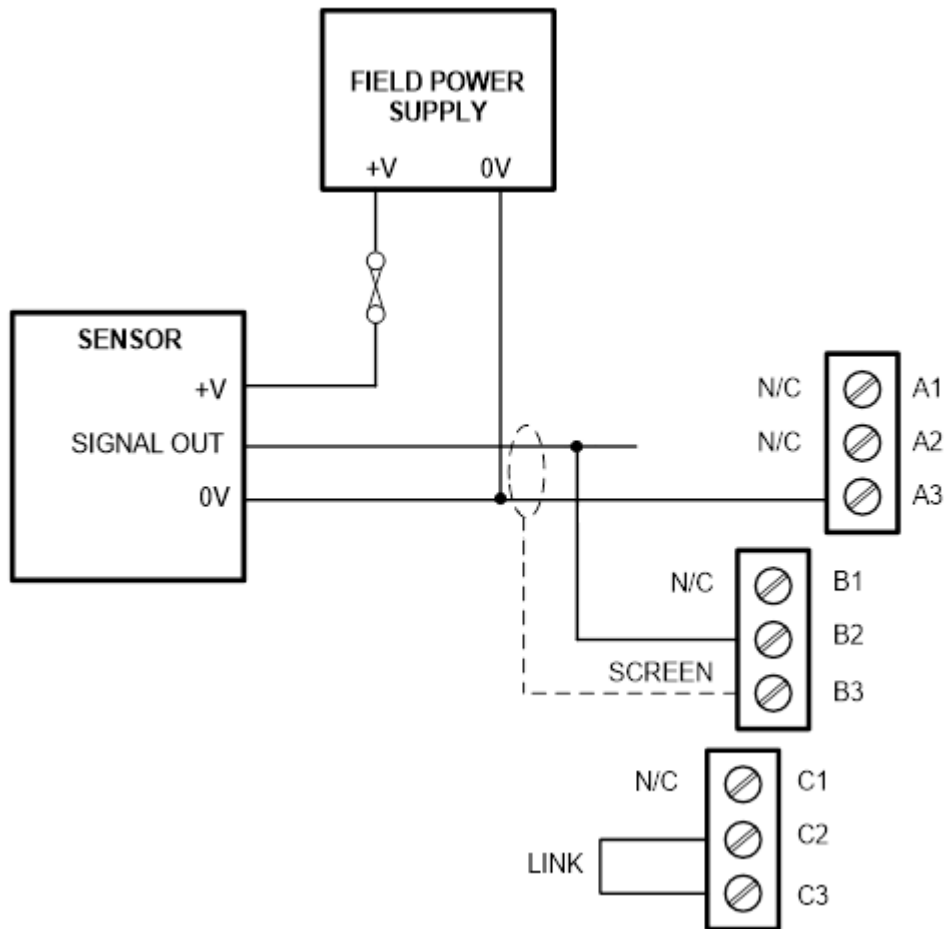

Figure 5 Active Totem Pole Output Sensor (Externally Derived Field Supply)

## 4.2. Active Open Collector Output Sensor Types

### 4.2.1. Sensor Power Derived From FTA

Figure 6 shows a typical field connection scheme for +24 Vdc field powered speed sensors with open collector outputs. This arrangement uses the fused field supply derived from the FTA.

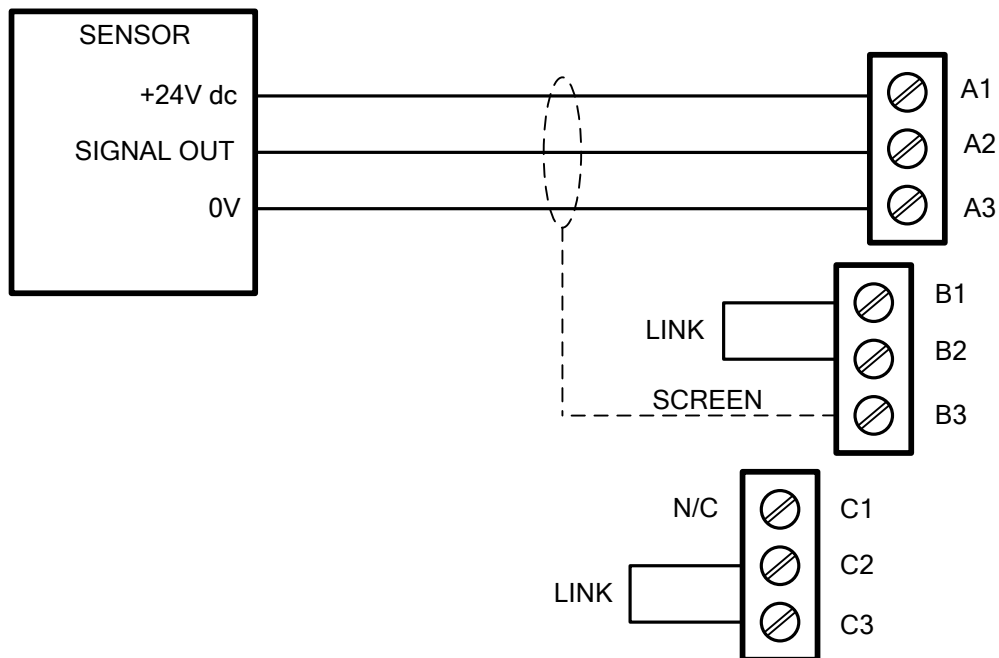

Figure 6 Active Open Collector Output Sensor (FTA Derived Field Supply)

### 4.2.2. Sensor Power Derived Externally

Figure 7 shows a typical connection scheme for field powered speed sensors with open collector outputs. This arrangement uses an external fused field supply.

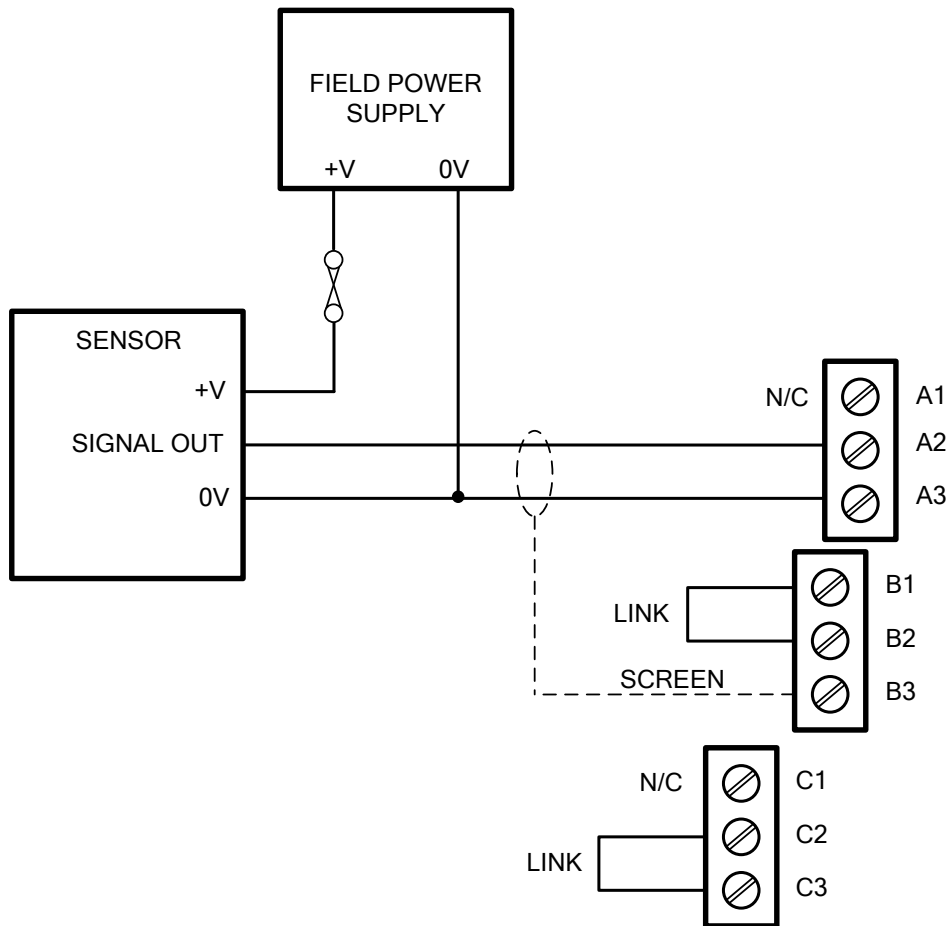

Figure 7 Active Open Collector Output (Externally Derived Field Supply)

### 4.3. Passive Output Sensor Types

Figure 8 shows a typical field connection scheme for passive inductive pick-up speed sensors.

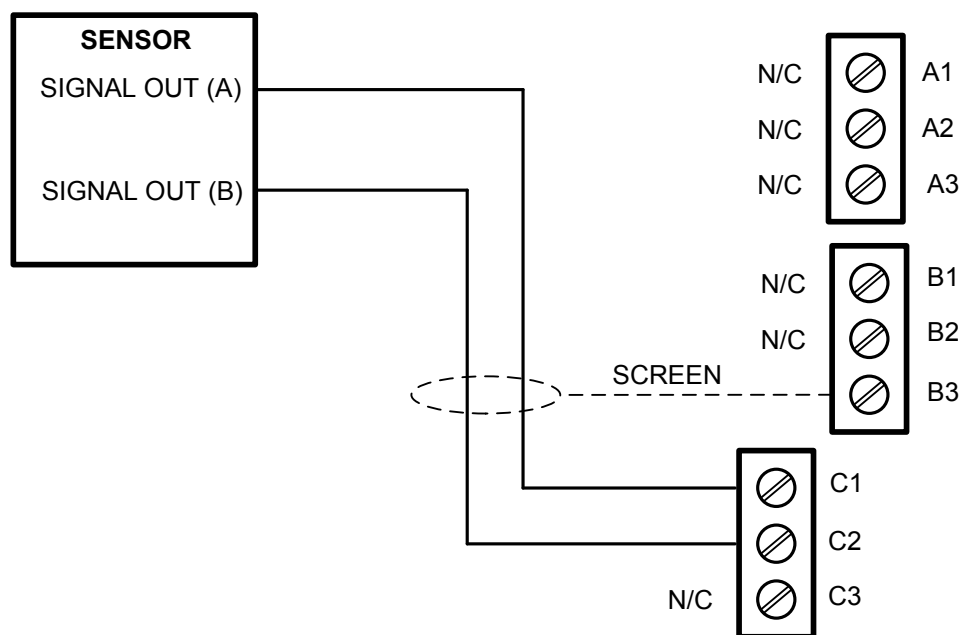

Figure 8 Passive Output Sensor Connections

### 4.4. Chassis Ground Connections

The chassis ground plane on the T8846 is common across all groups of speed inputs and Speed Monitor interface connections.

The screening shield of each speed input signal cable should be connected to chassis ground at the T8846 assembly.

Each speed input channel has a terminal to allow connection of the screening shield to chassis ground, Refer to Section 3.3 for connection details.

The T8846 chassis ground plane must be connected to a local chassis ground close to where the assembly is mounted.

There are two studs provided on the assembly to allow this connection to be made. These are marked as TERM1 and TERM2 on the PCB silkscreen legend.

---

**Note:** Only one connection should be made between the T8846 and local chassis ground.

---

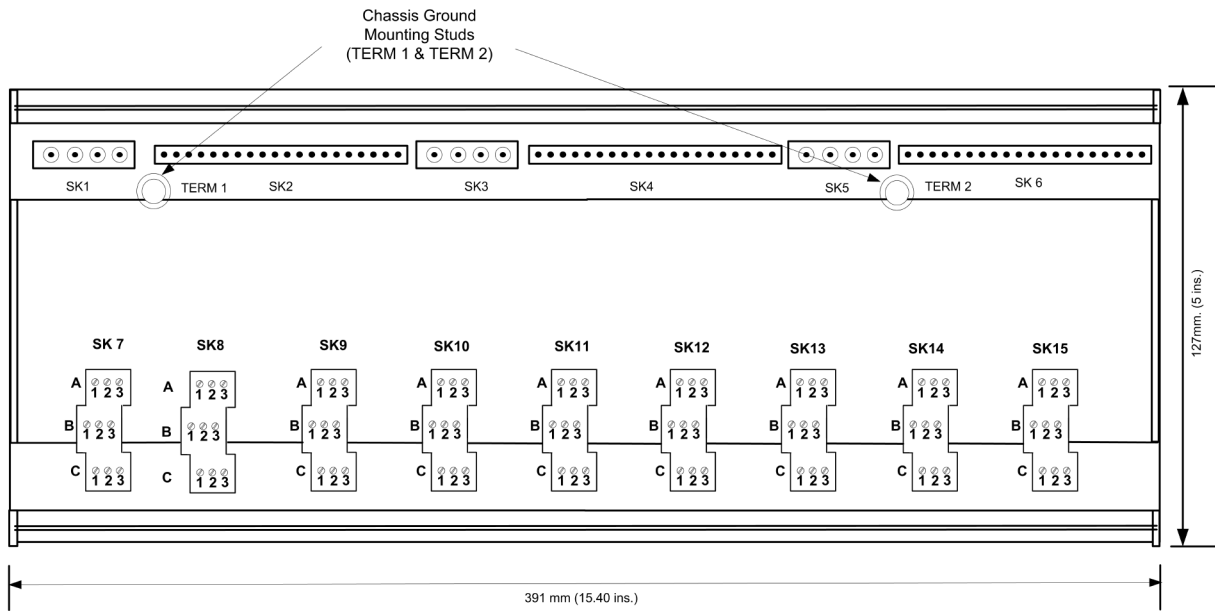

Figure 9 Chassis Ground Connections

## 5. Specifications

### 5.1. Group Vfield Power Supply Input Specifications

Parameter	Min	Type	Max	Unit	Notes
Group Vfield Input Voltage Range Vfield (A) and Vfield (B) Inputs	18		32	Vdc	With respect to Group Vfield Return
Maximum Group Vfield Input Current Vfield (A) and Vfield (B) Inputs			1	A	

Table 7 Group Vfield Power Supply Input Specifications

### 5.2. Group Speed Input Specifications

Parameter	Min	Type	Max	Unit	Notes
<b>Group Vfield Output</b>					
Group Vfield output voltage @ 50 mA load current		22.6		Vdc	Vfield input voltages @ 24 Vdc
Maximum Group Vfield output current		62.5		mA	
<b>Group Speed Inputs</b>					
Open Collector Input Pull-up resistance to Group Vfield		2000		$\Omega$	
Maximum Open Collector Input Voltage			33	V	With respect to Group Vfield Return
Open collector Input to Open collector output resistance		4990		$\Omega$	
Active Input Bias Voltage output with respect to Group Vfield Return		1.90		Vdc	Group Vfield Input = 24 Vdc
Differential input resistance Passive (A) and Passive (B) Inputs		632		$\Omega$	

Parameter	Min	Type	Max	Unit	Notes
Maximum Differential Input Voltage Passive (A) and Passive (B) Inputs			10	V	632 $\Omega$ input resistance

Table 8 Group Speed Input Specifications

### 5.3. General Specifications

Parameter	Min	Type	Max	Unit	Notes
<b>Temperature</b>					
Operating temperature	0		+60	°C	
Storage temperature	-25		+70	°C	
Temperature change			$\pm 0.5$	°C/min	
Relative Humidity range (operating, storage & transport)	10		95	%	Non-Condensing
<b>Dimensions</b>					
Height		102 (4.0)		mm (in)	Refer to Figure 3
Width		391 (15.40)		mm (in)	
Depth		127 (5.0)		mm (in)	
Weight		0.75 (1.6)		kg (lb)	

Table 9 General Specifications

### 5.4. Isolation Specification

Isolation	Level
Between Speed Groups 1, 2 & 3	50 V Reinforced (continuous) <sup>(1)</sup> 250 V Basic (fault) <sup>(2)</sup> [Type tested at 2436 Vdc for 60 s].
Between Chassis Ground and Speed Groups 1, 2 & 3	

Note 1) 50 Vrms Secondary circuit derived from Mains, OVC II up to 300V.

Note 2) 250 Vrms Mains circuit, OVC II up to 300V. Exposure to voltages at these levels shall be temporally constrained consistent with the system MTTR.