



Redundancy Power Supply - 24V, 20 A, 480 W, Single-phase

Catalog Numbers 1606-XLE480ERL, -XLE480ERZ, -XLE480CRZ,
-XLE480EDRZ



Allen-Bradley

by ROCKWELL AUTOMATION

Reference Manual

Original Instructions

Important User Information

Read this document and the documents listed in the additional resources section about installation, configuration, and operation of this equipment before you install, configure, operate, or maintain this product. Users are required to familiarize themselves with installation and wiring instructions in addition to requirements of all applicable codes, laws, and standards.

Activities including installation, adjustments, putting into service, use, assembly, disassembly, and maintenance are required to be carried out by suitably trained personnel in accordance with applicable code of practice.

If this equipment is used in a manner not specified by the manufacturer, the protection provided by the equipment may be impaired.

In no event will Rockwell Automation, Inc. be responsible or liable for indirect or consequential damages resulting from the use or application of this equipment.

The examples and diagrams in this manual are included solely for illustrative purposes. Because of the many variables and requirements associated with any particular installation, Rockwell Automation, Inc. cannot assume responsibility or liability for actual use based on the examples and diagrams.

No patent liability is assumed by Rockwell Automation, Inc. with respect to use of information, circuits, equipment, or software described in this manual.

Reproduction of the contents of this manual, in whole or in part, without written permission of Rockwell Automation, Inc., is prohibited.

Throughout this manual, when necessary, we use notes to make you aware of safety considerations.



WARNING: Identifies information about practices or circumstances that can cause an explosion in a hazardous environment, which may lead to personal injury or death, property damage, or economic loss.



ATTENTION: Identifies information about practices or circumstances that can lead to personal injury or death, property damage, or economic loss. Attentions help you identify a hazard, avoid a hazard, and recognize the consequence.

IMPORTANT Identifies information that is critical for successful application and understanding of the product.

Labels may also be on or inside the equipment to provide specific precautions.



SHOCK HAZARD: Labels may be on or inside the equipment, for example, a drive or motor, to alert people that dangerous voltage may be present.



BURN HAZARD: Labels may be on or inside the equipment, for example, a drive or motor, to alert people that surfaces may reach dangerous temperatures.



ARC FLASH HAZARD: Labels may be on or inside the equipment, for example, a motor control center, to alert people to potential Arc Flash. Arc Flash will cause severe injury or death. Wear proper Personal Protective Equipment (PPE). Follow ALL Regulatory requirements for safe work practices and for Personal Protective Equipment (PPE).

Table of Contents

Product Overview	5
Specifications	6
Catalog Numbers	6
AC Input	7
DC Input	8
Input Inrush Current	9
Output	10
Hold-up Time	11
DC OK Relay Contact	12
Efficiency and Power Losses	13
Lifetime Expectancy	14
Mean Time Between Failure	14
Functional Diagram	15
Terminals and Wiring	16
Instructions for Wiring	16
Replacing Units While the System is Running	17
Replacement Instructions	17
Front Side and User Elements	18
Electromagnetic Capability	19
Environment	20
Safety and Protection Features	21
Dielectric Strength	22
Certifications and Standards Compliance	23
Approximate Dimensions	24
Applications Notes	25
Peak Current Capability	25
Adjusting the Output Voltage	26
Charging of Batteries	27
Output Circuit Breakers	27
Series Operation	28
Parallel Use to Increase Output Power	29
Parallel Use For Redundancy	30
Operation on Two Phases	31
Use in a Tightly Sealed Enclosure	31
Mounting Orientations	32
Additional Resources	33

Notes

Product Overview



The Bulletin 1606-XLE line features cost optimized power supplies without compromising quality, reliability, and performance. The 1606-XLE480ERL and 1606-XLE480ERZ power supplies offer high efficiency, electronic inrush current limitation, active PFC, wide operational temperature range, and compact size. The units include a decoupling MOSFET for building 1+1 or n+1 redundant power supply systems.

These redundancy power supplies come with three connection terminal options; screw terminals, spring-clamp terminals or, plug connector terminals that allow replacement on an active application.

Catalog number 1606-XLE480EDRZ features an enhanced DC input voltage range and catalog number 1606-XLE480ECRZ is additionally equipped with conformal coated printed circuit boards.

These power supplies are suitable for a wide range of applications due to high immunity to transients and power surges, low electromagnetic emission, a DC OK signal contact for remote monitoring, and extensive international approvals.

- AC 100...240V Wide-range Input
- Width only 48 mm (1.89 in)
- Built-in Decoupling Mosfet for 1+1 and n+1 Redundancy
- Efficiency up to 95.2%
- 20% Output Power Reserves
- Safe HiccupPLUS Overload Mode
- Easy Fuse Breaking – 3 times nominal current for 12 ms
- Active Power Factor Correction (PFC)
- Minimal Inrush Current Surge
- Full Power Between -40...+60 °C (-40... +140 °F)
- DC OK Relay Contact
- Current Sharing Feature Included

Specifications

Attribute	Value	Notes
Output current	24V DC	Nominal
Adjustment range	–	–
Output current	24 A	Below +45 °C (+113° F) ambient
	20 A	At +60 °C (+140 °F) ambient
	15 A	At +70 °C (+158 °F) ambient
	Derate linearly between +45...70 °C (113...158 °F)	
AC Input voltage	100...240V AC	-15%/+10%
Mains frequency	50...60, 50 Hz	±6%
AC Input current	4.28/2.25 A	At 120/230V AC
Power factor	0.99/0.98	At 120/230V AC
Input voltage DC	DC 110...150V ^{±20%}	For 1606-XLE480ERxx
	DC 110...300V ^{±20%}	For 1606-XLE480EDxx
Input current DC	4.64 A/1.66 A	At 110/300V DC
AC Inrush current	10/4.5 Apk	At 120/230V AC
Efficiency	93.8/95.2%	At 120/230V AC
Losses	31.7/24.2 W	At 120/230V AC
Hold-up time	32/32 ms	At 120/230V AC
Temperature range	-40...+70 °C (-40...+158 °F)	–
Size (w x h x d)	48 x 124 x 127 mm (1.89 x 4.88 x 5 in.)	Without DIN rail and plug connectors
Weight	830 g (1.83 lb)	1606-XLE480ERL
	850 g (1.87 lb)	1606-XLE480ERZ

Catalog Numbers

Catalog Number	Description
1606-XLE480ERL	24V, 20 A 480 W Single-phase power supply with quick connect, spring-clamp terminals
1606-XLE480ERZ	24V, 20 A 480 W Single-phase power supply with hot swappable plug connectors
1606-XLE480ECRZ	24V, 20 A 480 W Single-phase power supply with conformal coated printed circuit boards
1606-XLE480EDRZ	24V, 20 A 480 W Single-phase power supply with enhanced DC input
1606-XLA-W50	Wall Mount Bracket

AC Input

The device is suitable to be supplied from TN-, TT-, and IT mains networks with AC voltage. For suitable DC supply voltages See [DC Input on page 8](#).

Attribute	Value	Notes
AC input	Nom AC 100...240V	–
AC input range	Min 85...264V AC	Continuous operation
	Min 264...300V AC	For maximal 500 ms (occasional)
Allowed voltage L or N to earth	Max 300V AC	Continuous, according to IEC 62477-1
Input frequency	Nom 50...60Hz	±6%
Turn-on voltage	Typ 82V AC	Steady-state value, see Figure 1 .
Shut-down voltage	Typ 72V AC	Steady-state value, see Figure 1 .
External input protection		

		AC 100V	AC 120V	AC 230V	Notes
Input current	Typ	5.17 A	4.28 A	2.25 A	At 20 A, see Figure 3 .
Power factor	Typ	0.996	0.996	0.980	At 20 A, see Figure 4 .
Crest factor	Typ	1.65	1.63	1.63	At 20 A, The crest factor is the mathematical ratio of the peak value to RMS value of the input current waveform.
Startup delay	Typ	450 ms	450 ms	450 ms	See Figure 2 .
Rise time	Typ	145 ms	145 ms	145 ms	At 20 A const. current load, 0mF load capacitance, see Figure 2 .
	Typ	160 ms	160 ms	160 ms	At 20 A const. current load, 20mF load capacitance, see Figure 2 .
Turn-on overshoot	Max	1000 mV	1000 mV	1000 mV	See Figure 2 .

Figure 1 - Input Voltage Range

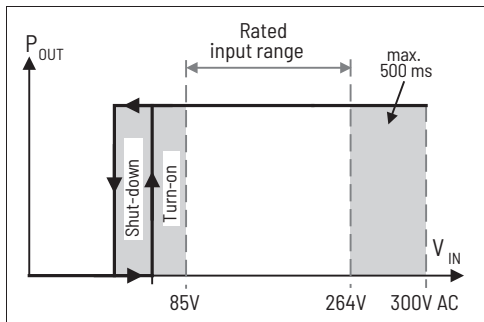

Figure 2 - Turn-on Behavior, Definitions

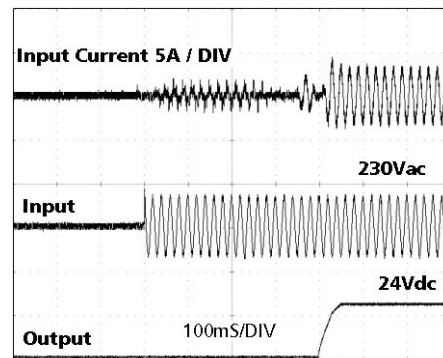

Figure 3 - Input Current Versus Output Current

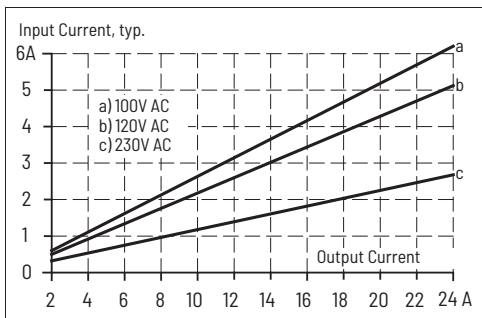
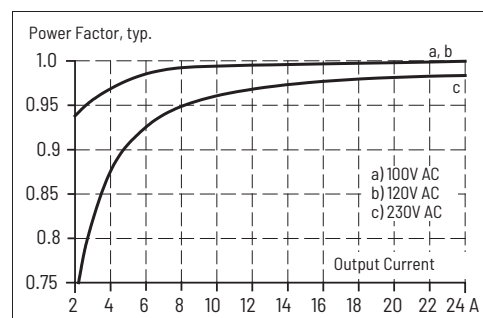

Figure 4 - Power Factor Versus Output Current



DC Input

The device is suitable to be supplied from a DC input voltage. Use a battery or a similar DC source. A supply from the intermediate DC-bus of a frequency converter is not recommended and can cause a malfunction or damage the unit.

Connect +pole to L, –pole to N and the PE terminal to an earth wire or to the machine ground.

Attribute		Value	Notes
DC input	Nom	DC 110...150V	±20% for 1606-XLE480ER_
	Nom	DC 110...300V	±20% for 1606-XLE480EC_
DC input range	Min	88...180V DC	Continuous operation for 1606-XLE480ER_
		88...360V DC	Continuous operation for 1606-XLE480EC_
DC input current	Typ	4.64 A	At 110V DC and 20 A load current
	Typ	1.66 A	At 300V DC and 20 A load current
Allowed Voltage (+) or (-) input to Earth	Max	375V DC	Continuous according to IEC 62477-1
Turn-on voltage	Typ	80V DC	Steady state value
Shut-down voltage	Typ	70V DC	Steady state value

Figure 5 - Wiring for DC Input

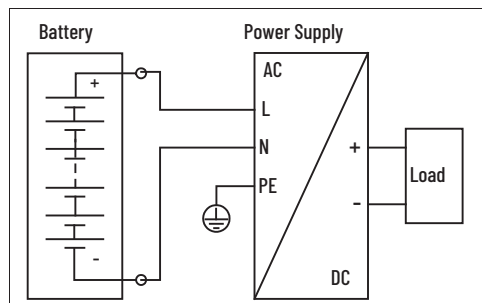

Input Inrush Current

An active inrush limitation circuit limits the input inrush current after turn-on of the input voltage.

The charging current into EMI suppression capacitors is disregarded in the first microseconds after switch-on.

Attribute		AC 100V	AC 120V	AC 230V	Notes
Inrush current	Max	15 A _{peak}	12 A _{peak}	5.5 A _{peak}	Temperature independent
	Typ	12 A _{peak}	10 A _{peak}	4.5 A _{peak}	Temperature independent
Inrush energy	Max	1 A _{2s}	1 A _{2s}	1 A _{2s}	Temperature independent

Figure 6 - Typical Turn-on Behavior at Nominal Load and 25 °C (77 °F) Ambient

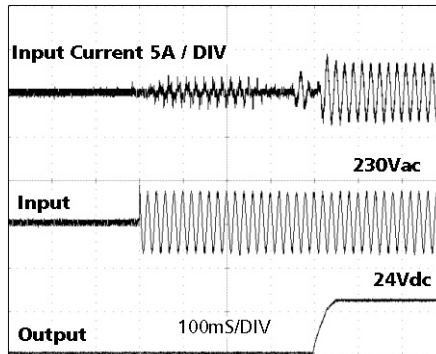

Output

The output provides a SELV/PELV/ES1 rated voltage, which is galvanically isolated from the input voltage. The output of the devices includes a decoupling MOSFET for building 1+1 or n+1 redundant power supply systems.

The device is designed to supply any kind of loads, including capacitive and inductive loads. If large capacitors, such as electric double layer capacitors (EDLCs or “UltraCaps”) with a capacitance > 1 F are connected to the output, the unit might charge the capacitor in the Hiccup^{PLUS} mode.

The device is featured with a “soft output regulation characteristic” to achieve current share between multiple devices when they are connected in parallel. The “soft output regulation characteristic” regulates the output voltage in such a manner that the voltage at no load is approximately 4% higher than at nominal load.

Attribute		Value	Notes
Output voltage	Nom	DC 24V	23.8...25.2V
Adjustment range		See Adjusting the Output Voltage on page 26	
Factory settings		24.1V	±0.2%, at 20 A, cold unit (results to Typ 23.9V±0.2% at 24 A and Typ 25.1V±0.2% at no load)
Line regulation	Max	10 mV	85...300V AC
Load regulation	Typ	1000 mV	Static value, 0 A --> 20 A; see Figure 7 .
Ripple and noise	Max	100 mVpp	20 Hz...20 MHz, 50 Ω
Output current	Nom	24A ⁽¹⁾	Below 45 °C (113 °F) ambient temperature, see Figure 22 .
	Nom	20 A	At 60 °C (140 °F) ambient temperature, see Figure 22 .
	Nom	15 A	At 70 °C (158 °F) ambient temperature, see Figure 22 .
Fuse breaking ⁽²⁾	Typ	60 A	Up to 12 ms once every 5 seconds, see Figure 9 .
Overload protection		Included	Electronically protected against overload, no-load, and short-circuits. In a protection event, audible noise may occur.
Overload behavior		Continuous current	Output voltage >13V DC, see Figure 7 .
		Intermittent current ⁽³⁾	Output voltage <13V DC, see Figure 7 .
Overload/ short-circuit current	Max	29.8 A	Continuous current, see Figure 7 .
	Typ	29 A	Intermittent current peak value for Typ 2 s Load impedance 10 mΩ, see Figure 8 . Discharge current of output capacitors is not included
	Max	9.8 A	Intermittent current average value (R.M.S.) Load impedance 10 mΩ, see Figure 8 .
Output capacitance	Typ	8 000 µF	Included inside the power supply
Back-feeding loads	Max	35V	The unit is resistant and does not show malfunctioning when a load feeds back voltage to the power supply. It does not matter whether the power supply is on or off. The absorbing energy can be calculated according to the built-in large sized output capacitor.

(1) This current is also available for temperatures up to +70°C (158 °F) with a duty cycle of 10% and/ or not longer than 1 minute every 10 minutes.

(2) The fuse braking current is an enhanced transient current which helps to start heavy loads or to trip fuses on faulty output branches. The output voltage stays above 20V. See [Peak Current Capability on page 25](#) for additional measurements.

(3) At heavy overloads (when output voltage falls below 13V), the power supply delivers continuous output current for 2s. After this, the output is switched off for approx. 18 s before a new start attempt is automatically performed. This cycle is repeated as long as the overload exists. If the overload has been cleared, the device will operate normally. See [Figure 8](#).

Figure 7 - Output Voltage Versus Output Current, Typical

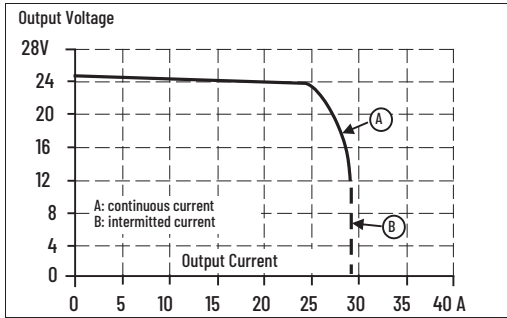

Figure 8 - Short-Circuit on Output, Hiccup^{PLUS} Mode, Typical

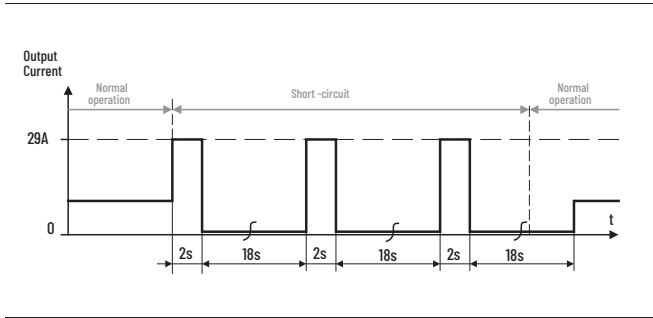
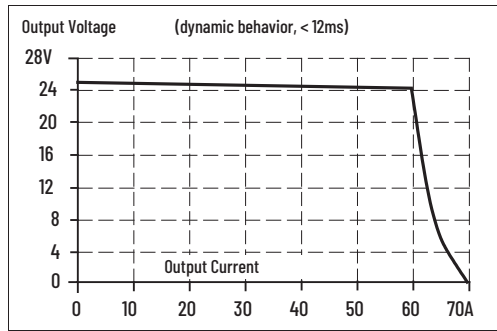

Figure 9 - Dynamic Overcurrent, Capability, Typical



Hold-up Time

Attribute		AC 100V	AC 120V	AC 230V	Notes
Hold-up Time	Typ	65 ms	65 ms	65 ms	At 10 A, see Figure 10
	Min	54 ms	54 ms	54 ms	At 10 A, see Figure 10
	Typ	32 ms	32 ms	32 ms	At 20 A, see Figure 10
	Min	24 ms	24 ms	24 ms	At 20 A, see Figure 10

Figure 10 - Hold-up Time Versus Input Voltage

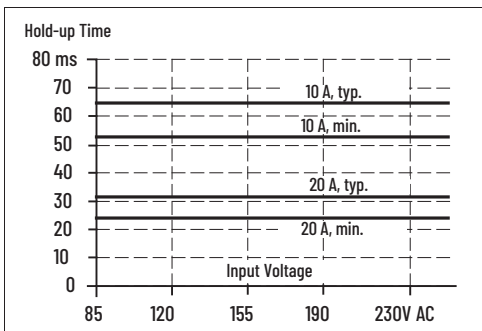
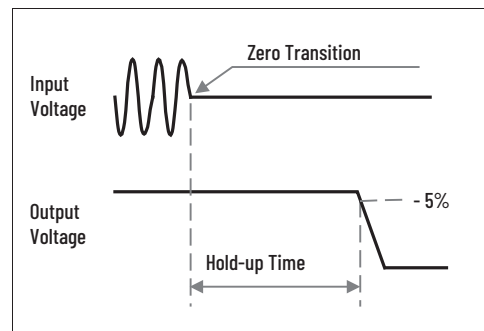

Figure 11 - Shut-down Behavior, Definitions



DC OK Relay Contact

This feature monitors the output voltage of the power supply in front of the decoupling device.

Attribute	Value
Contact closes	As soon as the output voltage reaches Typ 22V DC.
Contact opens	As soon as the output voltage dips below 22V DC. Short dips will be extended to a signal length of 100 ms. Dips shorter than 1 ms will be ignored.
Switching	TV
Contact ratings	Maximal 60V DC: 0.3 A, 30V DC: 1A, 30V AC: 0.5A, resistive load
Minimal permissible load: 1 mA at 5V DC	
Isolation voltage	See Dielectric Strength on page 22

Figure 12 - DC OK Relay Contact Behavior

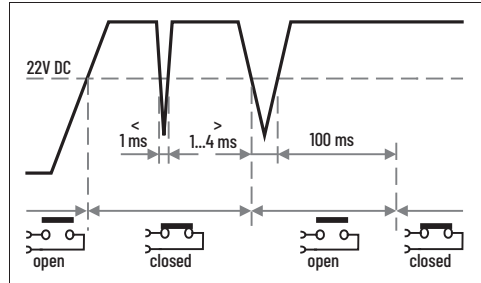

Efficiency and Power Losses

Attribute		AC 100V	AC 120V	AC 230V	Notes
Efficiency	Typ	93.2%	93.8%	95.2%	At 20 A
	Typ	93.1%	93.7%	95.1%	At 24 A (Power Boost)
Average efficiency ⁽¹⁾	Typ	92.8%	93.4%	94.6%	25% at 0.5 A, 25% at 10 A, 25% at 15 A, 25% at 20 A
Power losses	Typ	3.9 W	3.5 W	3.3 W	At 0 A
	Typ	17.4 W	16.4 W	13.8 W	At 10 A
	Typ	35.0 W	31.7 W	24.2 W	At 20 A
	Typ	42.7 W	38.7 W	29.7 W	At 24 A (Power Boost)

(1) The average efficiency is an assumption for a typical application where the power supply is loaded with 25% of the nominal load for 25% of the time, 50% of the nominal load for another 25% of the time, 75% of the nominal load for another 25% of the time and with 100% of the nominal load for the rest of the time.

Figure 13 - Efficiency Versus Output Current, Typical

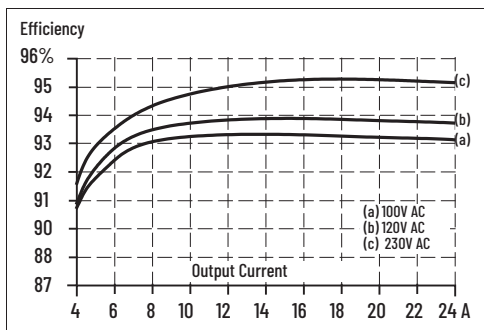

Figure 14 - Losses Versus Output Current, Typical

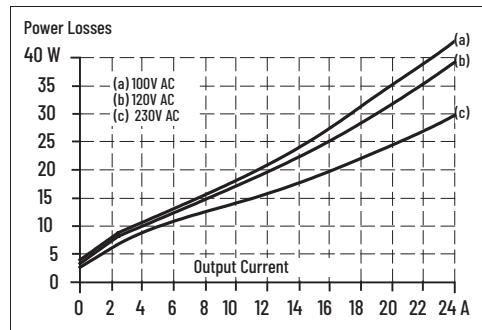

Figure 15 - Efficiency Versus Input Voltage at 20 A, Typical

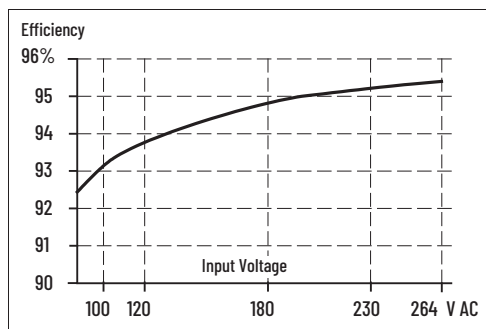
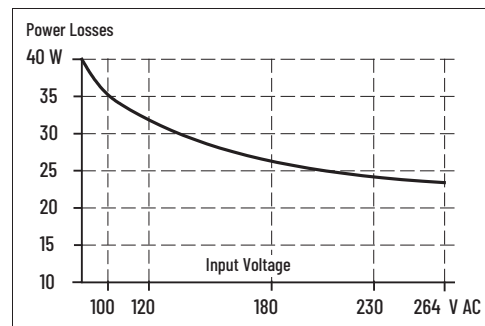

Figure 16 - Losses Versus Input Voltage at 20 A, Typical



Lifetime Expectancy

The Lifetime expectancy that is shown in the table indicates the minimum operating hours (service life) and is determined by the lifetime expectancy of the built-in electrolytic capacitors. Lifetime expectancy is specified in operational hours and is calculated according to the capacitor’s manufacturer specification. The manufacturer of the electrolytic capacitors only guarantees a maximum life of up to 15 years (131,400 hr). Any number exceeding this value is a calculated theoretical lifetime that can be used to compare devices.

Attribute	AC 100V	AC 120V	AC 230V	Notes
Lifetime expectancy	117,000 hr	136,000 hr	164,000 hr	At 10 A and 40 °C (140 °F)
	331,000 hr	386,000 hr	465,000 hr	At 10 A and 25 °C (77 °F)
	40,000 hr	53,000 hr	90,000 hr	At 20 A and 40 °C (140 °F)
	114,000 hr	150,000 hr	253,000 hr	At 20 A and 25 °C (77 °F)
	16,000 hr	25,000 hr	47,000 hr	At 24 A and 40 °C (140 °F)
	44,000 hr	69,000 hr	134,000 hr	At 24 A and 25 °C (77 °F)

Mean Time Between Failure

Mean Time Between Failure (MTBF) is calculated according to statistical device failures, and indicates reliability of a device. It is the statistical representation of the likelihood of a unit to fail and does not necessarily represent the life of a product.

The MTBF figure is a statistical representation of the likelihood of a device to fail. An MTBF figure of, for example, 1,000,000 hr means that statistically one unit will fail every 100 hours if 10,000 units are installed in the field. However, it cannot be determined if the failed unit has been running for 50,000 hr or only for 100 hr.

For these types of units the MTTF (mean time to failure) value is the same value as the MTBF value.

Attribute	AC 100V	AC 120V	AC 230V	Notes
MTBF SN 29500, IEC 61709	387,000 hr	412,000 hr	543,000 hr	At 20 A and 40 °C (140 °F)
	723,000 hr	768,000 hr	976,000 hr	At 20 A and 25 °C (77 °F)
MTBF MIL HDBK 217F	164,000 hr	169,000 hr	199,000 hr	At 20 A and 40 °C (140 °F); Ground Benign GB40
	224,000 hr	231,000 hr	272,000 hr	At 20 A and 25 °C (77 °F); Ground Benign GB25
	34,000 hr	36,000 hr	42,000 hr	At 20 A and 40 °C (140 °F); Ground Fixed GF40
	45,000 hr	47,000 hr	56,000 hr	At 20 A and 25 °C (77 °F); Ground Fixed GF25

Functional Diagram

Figure 17 - Functional Diagram 1606-XLE480ERL

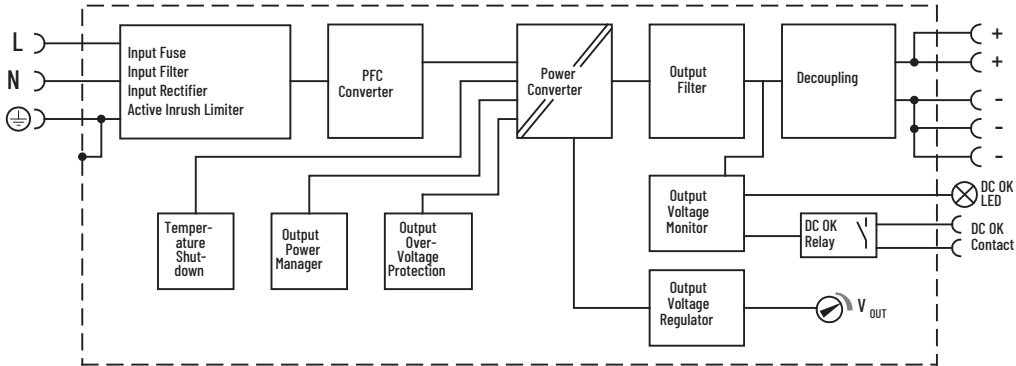
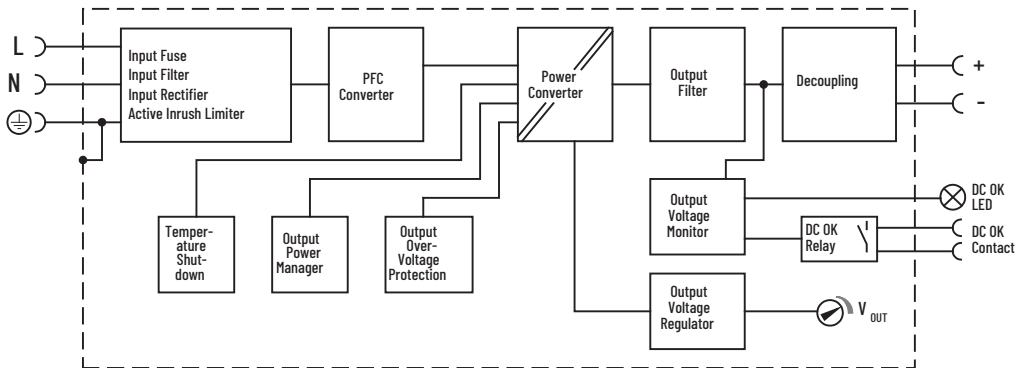

Figure 18 - Functional Diagram 1606-XLE480ERZ, -XLE480CRZ, -XLE480EDRZ



Terminals and Wiring

The terminals are IP20 fingersafe constructed and suitable for field- and factory wiring.

1606-XLE480ERL	Input	Output	DC OK-Signal
Type	Quick-connect spring-clamp termination		Push-in termination
Max Solid wire	6 mm ²		1.5 mm ²
Max Stranded wire	4 mm ²		1.5 mm ²
American Wire Gauge	AWG 20...10		AWG 24...6
Max wire diameter (including ferrules)	2.8 mm		1.6 mm
Wire stripping length	10 mm (0.4 in.)		7 mm (0.28 in.)
Screwdriver	—		3 mm slotted to open the spring
1606-XLE480ERZ, -XLE480EDRZ, -XLE480ECRZ	Input	Output	DC OK-Signal
Type	Plug connector with screw termination ⁽¹⁾		
Max Solid wire	4 mm ²	6 mm ²	1.5 mm ²
Max Stranded wire	2.5 mm ²	4 mm ²	1.5 mm ²
American Wire Gauge	AWG 20...12	AWG 24...10	AWG 24...16
Max wire diameter (including ferrules)	2.4 mm	3.2 mm	1.8 mm
Wire stripping length	7 mm (0.28 in.)	12 mm (0.47 in.)	6 mm (0.24 in.)
Screwdriver	3 mm (0.11 in.) slotted or cross-head No 2		3 mm (0.11 in.) slotted

(1) Do not unplug the connectors more than 20 times in total.

Instructions for Wiring

- Use appropriate copper cables that are designed for minimum operating temperatures of: 60 °C (140 °F) for ambient up to 45 °C (113 °F), 75 °C (167 °F) for ambient up to 60 °C (140 °F) and 90 °C (194 °F) for ambient up to 70 °C (158 °F) minimum.
- Follow national installation codes and installation regulations.
- Confirm that all strands of a wire enter the terminal connection.
- Unused terminal compartments should be securely tightened.
- Ferrules are allowed and recommended.

Replacing Units While the System is Running

This feature is available only for the 1606-XLE480ERZ, -XLE480CRZ, and -XLE480EDRZ units, which are equipped with hot-swappable plug connectors.

Figure 19 - Replacing the Power Supply or Redundancy Module while the System is Running

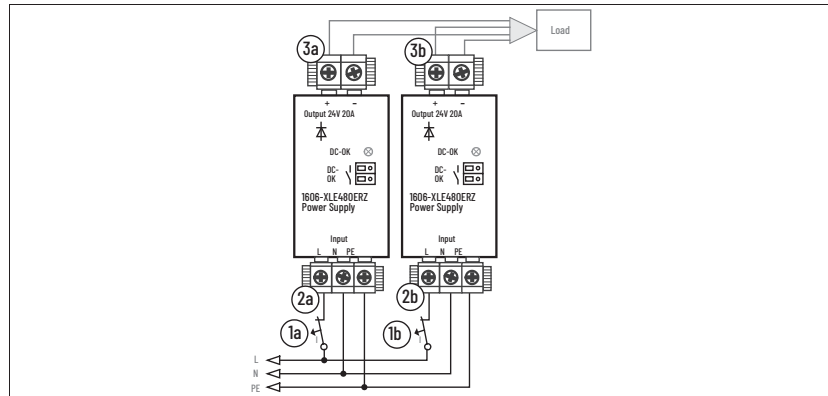

Replacement Instructions

Example for left power supply:

1. Switch-off circuit breaker (1a).
2. Remove plug (2a).
3. Remove plug (3a). The plug prevents the cables from shorting.
4. Change power supply.
5. Put the plug (3a) back in.
6. Put the plug (2a) back in.
7. Turn-on the circuit breaker (1a).
8. The circuit is redundant again.

To replace the right power supply, repeat the process above using (1 b), (2 b), and (3 b).

Front Side and User Elements

Figure 20 - 1606-XLE480ERL



Figure 21 - 1606-XLE480ERZ, -XLE480CRZ, -XLE480EDRZ



User Elements

1	Input Terminals	
	N, L	N, L Line Input
		PE (Protective Earth) Input
2	Output Terminals Two identical + poles and two identical - poles	
	+	Positive Output
	-	Negative (return) Output
3	Output Voltage Potentiometer	
4	DC OK light-emitting diode (LED) (green) On when the output voltage is above 22V.	
5	DC OK Relay Contact The DC OK relay contact is synchronized with the DC OK light-emitting diode (LED). See DC OK Relay Contact on page 12 .	

Electromagnetic Capability

The electromagnetic capability (EMC) behavior of the device is designed for applications in industrial environment as well as in residential, commercial, and light industry environments.

EMC Immunity ⁽¹⁾	According to the generic standards EN 61000-6-1 and EN 61000-6-2.			
Electrostatic discharge	EN 61000-4-2	Contact discharge Air discharge	8 kV 15 kV	Criterion A Criterion A
Electromagnetic RF field	EN 61000-4-3	80 MHz...2.7 GHz	20V/m	Criterion A
Fast transients (Burst)	EN 61000-4-4	Input lines Output lines DC OK signal (coupling clamp)	4 kV 2 kV 2 kV	Criterion A Criterion A Criterion A
Surge voltage on input	EN 61000-4-5	L → N L → PE, N → PE	2 kV 4kV	Criterion A Criterion A
Surge voltage on output	EN 61000-4-5	+ → - +/- → PE	1kV 2 kV	Criterion A Criterion A
Surge voltage on Signals	EN 61000-4-5	DC OK signal → PE	1kV	Criterion A
Conducted disturbance	EN 61000-4-6	0.15...80 MHz	20V	Criterion A
Mains voltage dips	EN 61000-4-11	0% of 100V AC 40% of 100V AC 70% of 100V AC 0% of 200V AC 40% of 200V AC 70% of 200V AC	0V AC, 20 ms 40V AC, 200 ms 70V AC, 500 ms 0V AC, 20 ms 80V AC, 200 ms 140V AC, 500 ms	Criterion A Criterion C Criterion C Criterion A Criterion A Criterion A
Voltage interruptions	EN 61000-4-11	0% of 200V AC (=0V)	5000 ms	Criterion C
Voltage sags	SEMI F47 0706	80% of 120V AC (96V AC) 70% of 120V AC (84V AC) 50% of 120V AC (60V AC)	1000 ms 500 ms 200 ms	Criterion A Criterion A Criterion A
Powerful transients	VDE 0160	Over entire load range	750V, 0.3 ms	Criterion A

(1) Criteria:

A: Power supply shows normal operation behavior within the defined limits.

C: Temporary loss of function is possible. Device may shut down and restarts by itself. No damage or hazards for the power supply will occur.

EMC Emission	According to the generic standards EN 61000-6-3 and EN 61000-6-4.	
Conducted emission input lines	EN 55011, EN 55015, EN 55022, FCC Part 15, CISPR 11, CISPR 22	Class B
Conducted emission output lines	IEC/CISPR 16-1-2, IEC/CISPR 16-2-1	5dB higher than average limits for DC power port according to EN 61000-6-3 ⁽¹⁾
Radiated emission	EN 55011, EN 55022	Class B
Harmonic input current	EN 61000-3-2	Class A equipment: fulfilled Class C equipment: fulfilled in the load range from 8 to 24 A
Voltage fluctuations, flicker	EN 61000-3-3	Fulfilled, tested with constant current loads, non-pulsing

This device complies with FCC Part 15 rules.

Operation is subjected to following two conditions: (1) this device may not cause harmful interference, and (2) this device must accept any interference received, including interference that may cause undesired operation.

(1) Restrictions apply for applications in residential, commercial and light-industrial environments, where local DC power networks according to EN 61000-6-3 are involved. No restrictions for all kinds of industrial applications.

Switching Frequencies

PFC converter	100 kHz	Fixed frequency
Main converter	80...140 kHz	Output load dependent
Auxiliary converter	60 kHz	Fixed frequency

Environment

Attribute	Value	Notes
Operational temperature	-40...+70 °C (-40...158°F)	Operational temperature is the same as the ambient or surrounding temperature and is defined as the air temperature 2 cm below the unit.
Storage temperature	-40...+85°C (-40...185°F)	For storage and transportation
Output de-rating	0.27 A/°C 0.5 A/°C 1.25 A/1000 m or 5°C/1000 m 0.75 A/-5 kPa or 3°C/-5 kPa	+45...60 °C (+113...140 °F) +60...70 °C (140...158 °F) For altitudes >2000 m (6560ft) See Figure 23 . For atmospheric pressures <80 kPa, See Figure 23
The de-rating is not hardware controlled. The customer has to take this into consideration to stay below the de-rated current limits in order not to overload the unit.		
Humidity	5 to 95% r.hr.	According to IEC 60068-2-30 Do not energize while condensation is present.
Atmospheric pressure	110...47 kPa	See Figure 23
Altitude	Up to 6000 m (20,000 ft)	
Over-voltage category	III	According to IEC 60664-1 for altitudes up to 2000m
	II	According to IEC 60664-1, for altitudes between 2000 and 6000 m and atmospheric pressures from 80...47 kPa.
Degree of pollution	2	According to IEC 62477-1, not conductive
Vibration sinusoidal	2...17.8 Hz: ±1.6mm; 17.8...500 Hz: 2g 2 hours/axis	According to IEC 60068-2-6
Shock	30g 6ms, 20g 11ms 3 bumps per direction, 18 bumps in total	According to IEC 60068-2-27
	Shock and vibration are tested in combination with DIN-Rails according to EN 60715 with a height of 15mm and a thickness of 1.3mm and standard orientation.	
LABS compatibility	As a rule, only non-silicon precipitating materials are used. The unit conforms to the LABS criteria and is suitable for use in paint shops.	
Corrosive gases	Tested according to ISA-71.04-1985, Severity Level G3 and IEC 60068-2-60 Test Ke Method 4 for a service life of minimum 10 years in these environments.	
Audible noise	Some audible noise may be emitted from the power supply during no load, overload or short circuit.	

Figure 22 - Output Current Versus Ambient Temperature

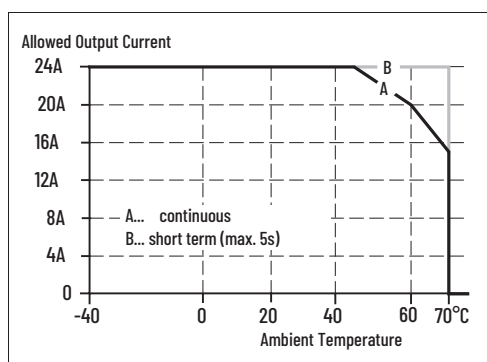
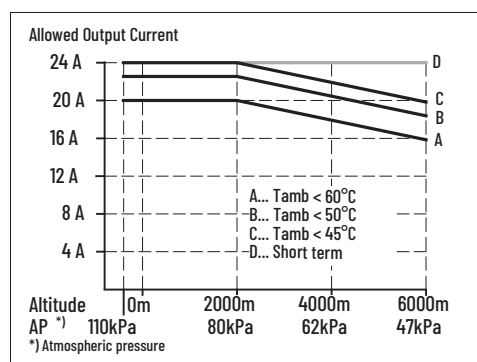

Figure 23 - Output Current Versus Altitude



Safety and Protection Features

Attribute		Value	Notes
Isolation resistance	Min	500 M Ω	At delivered condition between input and output, measured with 500V DC
	Min	500 M Ω	At delivered condition between input and PE, measured with 500V DC
	Min	500 M Ω	At delivered condition between output and PE, measured with 500V DC
	Min	500 M Ω	At delivered condition between output and DC OK contacts, measured with 500V DC
PE resistance	Max	0.10 Ω	Resistance between PE terminal and the housing in the area of the DIN rail mounting bracket.
Output over-voltage protection	Typ	30.5V DC	In case of an internal defect, a redundant circuit limits the maximum output voltage. The output shuts down and automatically attempts to restart.
	Max	32V DC	
Class of protection		I	According to IEC 61140 A PE (Protective Earth) connection is required
Degree of protection		IP 20	According to EN/IEC 60529
Over-temperature protection		Included	Output shut-down with automatic restart. Temperature sensors are installed on critical components inside the unit and turn the unit off in safety critical situations, which can happen e.g. when ambient temperature is too high, ventilation is obstructed or the de-rating requirements are not followed. There is no correlation between the operating temperature and turn-off temperature since this is dependent on input voltage, load and installation methods.
Input transient protection		MOV (Metal Oxide Varistor)	For protection values see Electromagnetic Capability on page 19
Internal input fuse		Included	Not user replaceable slow-blow high-braking capacity fuse
Touch current (leakage current)	Typ	0.12 mA/0.31 mA	At 100V AC, 50 Hz, TN-, TN- TN-TT-mains/IT-mains
	Typ	0.18 mA/0.45 mA	At 120V AC, 60...50 Hz, TN-, TN- TN-TT-mains/IT-mains
	Typ	0.30 mA/0.76 mA	At 230V AC, 50, 60 Hz, TN-, TN-TT-mains /IT-mains
	Max	0.16 mA/0.38 mA	At 110V AC, 50, 50 Hz, TN-/ IT-mainsmains
	Max	0.23 mA/0.55 mA	At 132V AC, 60, TN-/ 50Hz, TN-TT-mains /mains
	Max	0.39 mA/0.94 mA	At 264V AC, 50, 60Hz, TN-TT-mains /mains

Dielectric Strength

The output voltage is floating and has no ohmic connection to the ground. Type and routine tests are conducted by the manufacturer. Field tests may be conducted in the field using the appropriate test equipment which applies the voltage with a slow ramp (2 s up and 2 s down). Connect all input-terminals together as well as all output poles before conducting the test. When testing, set the cut-off current settings to the value in the table below.

		A	B	C	D ⁽¹⁾
Type test	60 s	2500V AC	3000V AC	1000V AC	500V AC
Routine test	5 s	2500V AC	2500V AC	500V AC	500V AC
Field test	5 s	2000V AC	2000V AC	500V AC	500V AC
Cut off current setting for field test		> 10 mA	> 10 mA	> 20 mA	> 1 mA





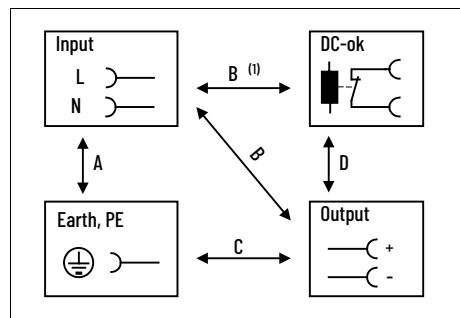



(1) When testing input to DC OK ensure that the maximal voltage between DC OK and the output is not exceeded (column D). We recommend connecting DC OK pins and the output pins together when performing the test.

Figure 24 - Dielectric Strength



It is recommended that either the + pole, TN-TT-mains the – pole or any other part of the output circuit shall be connected to the earth/ground system. This helps to avoid situations in which a load starts unexpectedly or cannot be switched off when unnoticed earth faults occur.

Certifications and Standards Compliance

EC Declaration of Conformity		The CE mark indicates conformance with the EMC directive (available), Low-voltage directive (available), and the ATEX directive (planned)
IEC 60950-1 2 nd Edition planned		CB Scheme, Information Technology Equipment
UL 508		Listed for use as Industrial Control Equipment; U.S.A. (UL 508) and Canada (C22.2 No. 107-1-01); E-File: E56639
ANSI/ISA 12.12.01 Class I Div 2 pending		Hazardous Location Class I Div 2 T4 Groups A,B,C,D systems; U.S.A. (ANSI/ISA 12.12.01) and Canada (C22.2 No. 213)
EN 60079-0, EN 60079-7 ATEX	 II 3G Ex ec nC II T4 Gc	Approval for use in hazardous locations Zone 2 Category 3G. Number of ATEX certificates: EPS 17 ATEX 1 089 X
IEC 60079-0, IEC 60079-7		Suitable for use in Class 1 Zone 2 Groups IIa, IIb and IIc locations. Number of IECEx certificates: EPS 17.0046X
EAC TR Registration (Cat. Nos. 1606-XLE480ERL and 1606-XLE480ERZ only)		Registration for the Eurasian Customs Union market (Russia, Kazakhstan, Belarus)
RoHS Directive		Directive 2011/65/EU of the European Parliament and the Council of June 8th, 2011 on the restriction of the use of certain hazardous substances in electrical and electronic equipment.
REACH Directive		Directive 1907/2006/EU of the European Parliament and the Council of June 1st, 2007 regarding the Registration, Evaluation, Authorization and Restriction of Chemicals (REACH)
IEC/EN 61558-2-16 (Annex BB)	Safety Isolating Transformer	Safety Isolating Transformers corresponding to Part 2-6 of the IEC/EN 61558

Approximate Dimensions

Attribute	Value
Width	48 mm (1.89 in.)
Height ⁽¹⁾	124 mm (4.88 in.)
Depth ⁽¹⁾	127 mm (5.0 in.) The DIN rail height must be added to the unit depth to calculate the total required installation depth.
Weight	830 g (1.83 lb) for 1606-XLE480ERL 850 g (1.87 lb) for 1606-XLE480ERZ
DIN rail	Use 35mm (1.38 in.) DIN-rails according to EN 60715 or EN 50022 with a height of 7.5 (.30 in.) or 15 mm (.60 in.)
Housing material	Body: Aluminum alloy Cover: zinc-plated steel
Installation clearances	Keep the following installation clearances: 40 mm (1.57 in.) on top, 20 mm (0.79 in.) on the bottom, 5 mm (.20 in.) on the left and right sides are recommended when the device is loaded permanently with more than 50% of the rated power. Increase this clearance to 15 mm (.60 in.) in case the adjacent device is a heat source (Example: another power supply).
Penetration protection	Small parts like screws with a diameter larger than 5mm (.20 in.)

(1) Without plug connectors.

Figure 25 - Front View 1606-XLE480ERL

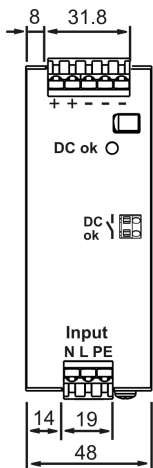

Figure 26 - Side View 1606-XLE480ERL

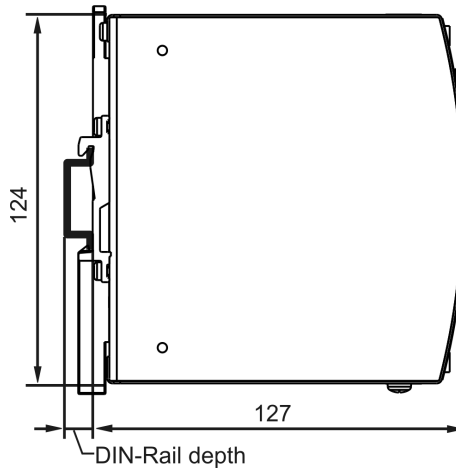

Figure 27 - Front view 1606-XLE480ERZ, -XLE480EDRZ -XLE480ECRZ

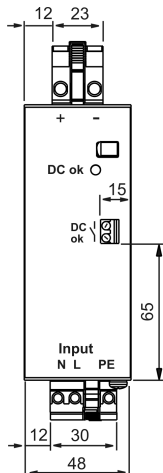
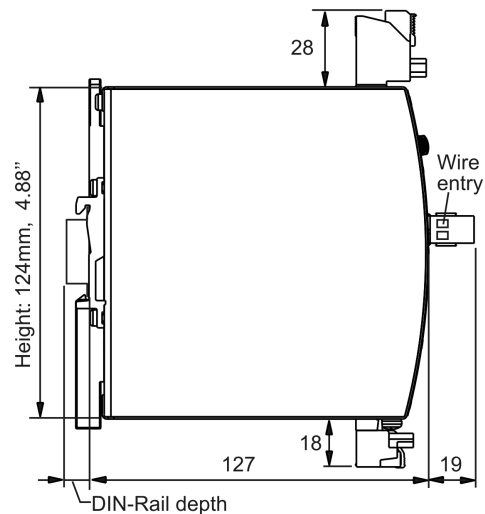

Figure 28 - Side view 1606-XLE480ERZ, -XLE480EDRZ -XLE480ECRZ



Applications Notes

Peak Current Capability

The unit can deliver peak currents (up to several milliseconds) which are higher than the specified short-term currents.

This helps to start current demanding loads. Solenoids, contactors and pneumatic modules often have a steady state coil and a pick-up coil. The inrush current demand of the pick-up coil is several times higher than the steady-state current and usually exceeds the nominal output current (including the Power Boost). The same situation applies when starting a capacitive load.

The peak current capability also ensures the safe operation of subsequent circuit breakers of load circuits. The load branches are often individually protected with circuit breakers or fuses. In case of a short or an overload in one branch circuit, the fuse or circuit breaker need a certain amount of over-current to open in a timely manner. This avoids voltage loss in adjacent circuits.

The extra current (peak current) is supplied by the power converter and the built-in large sized output capacitors of the power supply. The capacitors get discharged during such an event, which causes a voltage dip on the output. The following three examples show typical voltage dips for resistive loads:

Figure 29 - 40 A Peak Current for 50 ms, Typical (2x the Nominal Current)

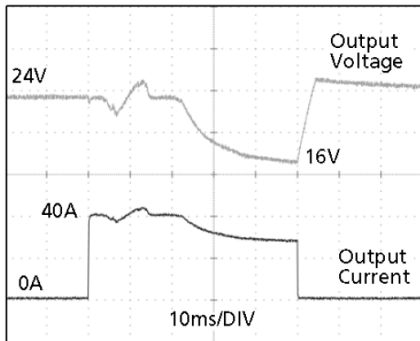

Figure 30 - 100 A Peak Current for 5 ms, Typical (5x the Nominal Current)

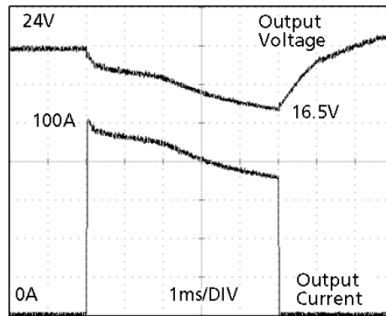
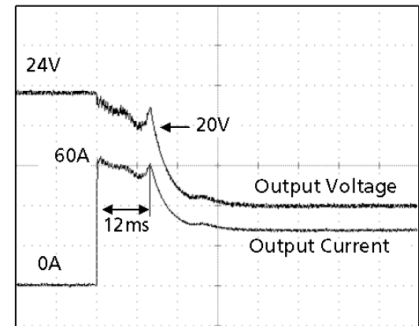

Figure 31 - 60 A Peak Current for 12 ms, Typical (3x the Nominal Current)



Peak Current Voltage Dips⁽¹⁾

Typ	from 24...16V	At 40 A for 50 ms, resistive load
Typ	from 24...21V	At 100 A for 2 ms, resistive load
Typ	from 24...16.5V	At 100 A for 5 ms, resistive load

(1) The DC OK relay might trigger when the voltage dips below 22V DC or longer than 1 ms.

Adjusting the Output Voltage

A voltage adjustment potentiometer can be found behind the flap on the front of the unit. However, it is not recommended to change the output voltage since load sharing between power supplies connected in parallel can only be achieved by a precise setting of the output voltages. The factory settings allow precise load sharing and only qualified personnel should change the adjustment potentiometer.

Attribute	Value	Notes
Lower end of the specified adjustment range		
Output voltage	Nom 24.0V	Due to the soft output voltage regulation characteristic (parallel mode feature) a setting to 24.0V results to an output voltage of 23.8V $\pm 0.2\%$ at 24 A and 25.0V $\pm 0.2\%$ at no load. See Figure 32 .
Output current	Min 24 A	At 45 °C (113 °F)
	Min 20 A	At 60 °C (140 °F)
	Min 15 A	At 70 °C (158 °F)
Reduce output current linearly between +At 45 °C (113 °F) and +70 °C.		
Upper end of the specified adjustment range		
Output voltage	Nom 28.0V	Due to the soft output voltage regulation characteristic (parallel mode feature) a setting to 28.0V results to an output voltage of 27.7V $\pm 0.2\%$ at 20.6A and 29.2V $\pm 0.2\%$ at no load. See Figure 32 .
Output current	Min 20.6 A	At 45 °C (113 °F)
	Min 17.1 A	At 60 °C (140 °F)
	Min 13.0 A	At 70 °C (158 °F)
Reduce output current linearly between +At 45 °C (113 °F) and +70 °C.		

The maximum output voltage can occur at the clockwise end position of the potentiometer due to tolerances is 30V. It is not guaranteed that this value can be achieved. The typical value is 29.5V.

Current values between 24...28V can be interpolated.

Figure 32 - Adjustment Range of the Output Voltage

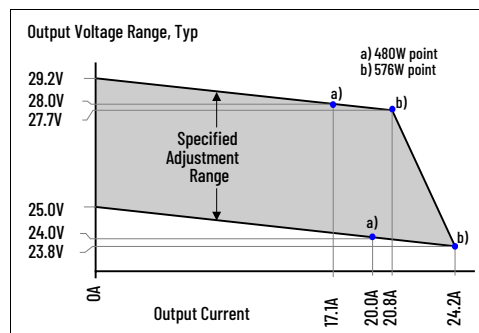

The output voltage shall only be changed when absolutely necessary. For example, battery charging, described next.

Charging of Batteries

This redundancy power supply is ideal for charging batteries due to the decoupling circuit built in to the output stage which does not require a fuse or diode between the power supply and the battery.

It can be used to charge sealed lead acid (SLA) or valve regulated lead acid (VRLA) lead batteries when following these instructions:

Set output voltage (measured at disconnected battery) very precisely to the end-of-charge voltage. Use the potentiometer, which is hidden behind the flap on the front of the unit. See [Adjusting the Output Voltage on page 26](#).

Battery Temperature	10 °C (50 °F)	20 °C (68°F)	30 °C (86°F)	40 °C (104°F)
End-of-charge	27.8V	27.5V	27.15V	26.8V

- Ensure that the ambient temperature of the power supply is below 40 °C.
- Use only matched batteries when connecting 12V types in series.
- The return current to the power supply (battery discharge current) is typically 11 mA when the power supply is switched off.

Output Circuit Breakers

Standard miniature circuit breakers are commonly used for AC-supply systems and may also be used on 24V branches.

MCB's are designed to protect wires and circuits. If the ampere value and the characteristics of the MCB are adapted to the wire size that is used, the wiring is considered as thermally safe regardless of whether the MCB opens or not.

To avoid voltage dips and under-voltage situations in adjacent 24V branches which are supplied by the same source, a fast (magnetic) tripping of the MCB is desired. A quick shutdown within 10ms is necessary corresponding roughly to the ride-through time of PLC's. This requires power supplies with high current reserves and large output capacitors.

Furthermore, the impedance of the faulty branch must be sufficiently small in order for the current to actually flow. The best current reserve in the power supply does not help if Ohm's law does not permit current flow. The following table has typical test results showing which B- and C-Characteristic MCBs magnetically trip depending on the wire cross section and wire length.

Figure 33 – Test Circuit

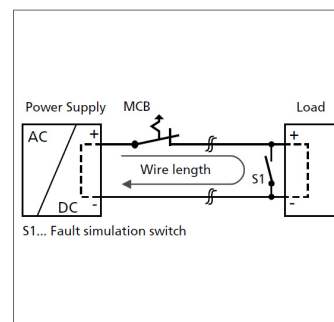

Maximal Wire Length ⁽¹⁾ for a Fast (magnetic) Tripping

	0.75 mm ²	1.0 mm ²	0.75 mm ²	0.75 mm ²
C-2A	34 m (111.5 ft)	45 m (148 ft)	64 m (210 ft)	101 m (331 ft)
C-3A	27 m (88.6 ft)	36 m (118 ft)	52 m (170.6 ft)	79 m (260 ft)
C-4A	19 m (62.4 ft)	26 m (85 ft)	35 m (114.8 ft)	56 m (184 ft)
C-6A	9 m (29.5 ft)	12 m (39.4 ft)	16 m (52.5 ft)	23 m (75.5 ft)
C-8A	4 m (13.1 ft)	8 m (26.25 ft)	12 m (39.4 ft)	18 m (59.1 ft)
C-10A	4 m (13.1 ft)	6 m (19.69 ft)	9 m (29.5 ft)	15 m (49.2 ft)
C-13A	2 m (6.56 ft)	3 m (9.8 ft)	4 m (13.1 ft)	5 m (16.4 ft)
B-6A	23 m (75.5 ft)	30 m (98.4 ft)	38 m (124.7 ft)	67 m (219.8 ft)
B-10A	11 m (36.1 ft)	14 m (45.9 ft)	21 m (68.9 ft)	32 m (105 ft)
B-13A	7 m (23 ft)	12 m (39.4 ft)	17 m (55.8 ft)	23 m (75.5 ft)
B-16A	4 m (13.1 ft)	6 m (19.69 ft)	8 m (26.25 ft)	11 m (36.1 ft)
B-20A	1 m (3.28 ft)	1 m (3.28 ft)	2 m (6.56 ft)	4 m (13.1 ft)

(1) Consider twice the distance to the load (or cable length) when calculating the total wire length (+ and - wire).

Series Operation

Power supplies of the same type can be connected in series for higher output voltages. It is possible to connect as many units in series as needed, providing the sum of the output voltage does not exceed 150V DC. Voltages with a potential above 60V DC must be installed with a protection against touching.

Avoid return voltage (for example, from a decelerating motor or battery) which is applied to the output terminals.

Keep an installation clearance of 15 mm (.05 in.) (left/right) between two power supplies and avoid installing the power supplies on top of each other. Do not use power supplies in series in mounting orientations other than the standard mounting orientation (input terminals on bottom of the unit).

Pay attention that leakage current, EMI, inrush current, harmonics will increase when using multiple power supplies.

Figure 34 - Series Operation

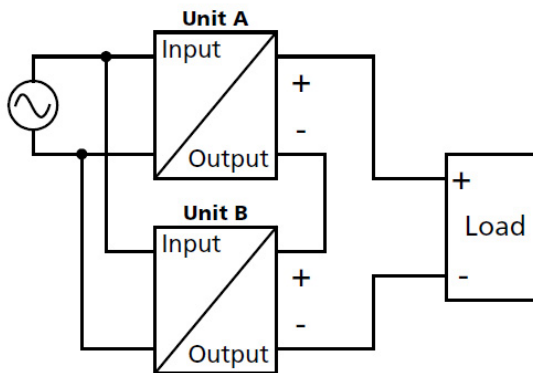

Parallel Use to Increase Output Power

Power supplies can be paralleled to increase the output power. For redundancy applications one extra power supply is always needed for sufficient output current in case one unit fails.

The unit is permanently set to “parallel use” mode in order to achieve load sharing between power supplies connected in parallel. The “Parallel use” mode regulates the output voltage in such a manner that the voltage at no load is approx. 4% higher than at nominal load.

Energize all units at the same time. It also might be necessary to cycle the input power (turn-off for at least five seconds), if the output was in overload or short circuits and the required output current is higher than the current of one unit.

Keep an installation clearance of 15mm (.05 in.)(left/right) between two power supplies and avoid installing the power supplies on top of each other.

Do not use power supplies in parallel in mounting orientations other than the standard mounting orientation (input terminals on bottom of the unit) or in any other condition where a derating of the output current is required (e.g. altitude).

Pay attention that leakage current, EMI, inrush current, harmonics will increase when using multiple power supplies.

Do not load paralleled power supplies with higher currents as shown in the following diagrams:

Figure 35 - Output Current Versus Ambient Temperature for Two Paralleled Units.

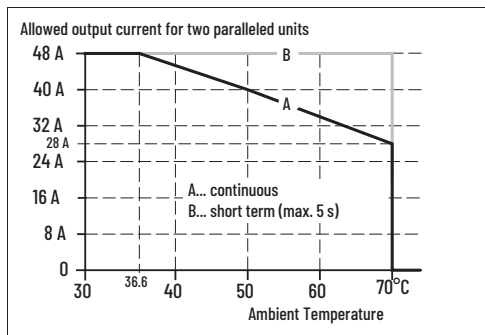
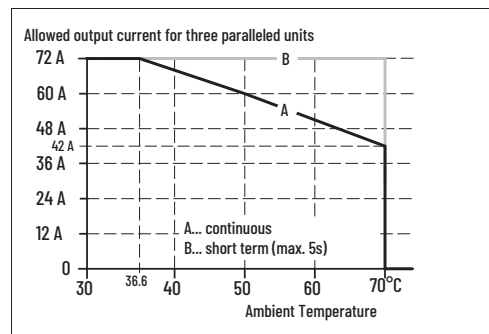

Figure 36 - Output Current Versus Ambient Temperature for Three Paralleled Units



Parallel Use For Redundancy

Power supplies can be paralleled for redundancy to gain higher system availability. The unit is already equipped with a MOSFET as decoupling device on the output to avoid, that a faulty unit becomes a load for the other power supplies and the output voltage cannot be maintained.

Recommendations for building redundant power systems:

- a. Use separate input fuses for each power supply.
- b. Monitor the individual power supply units by utilizing the built-in DC OK relay contacts on each power supply.

Figure 37 - Wiring Diagram, 1+1 Redundancy for 20 A Output Current

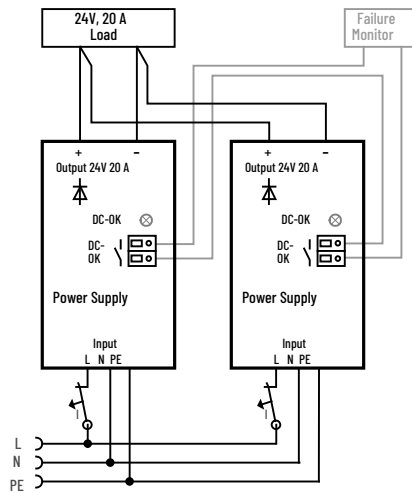
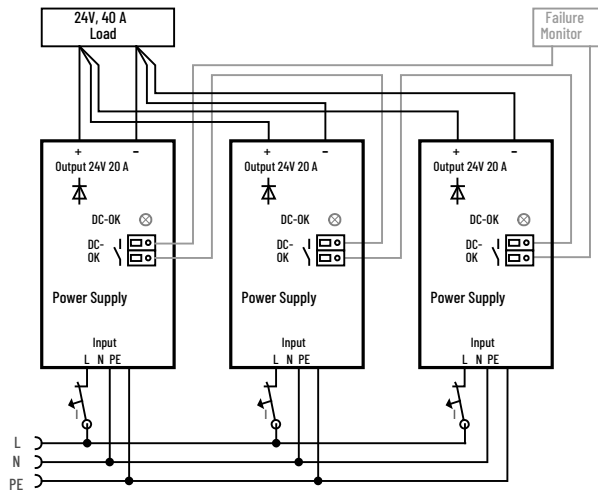

Figure 38 - Wiring Diagram, N+1 Redundancy for 40A Output Current^(a)



IMPORTANT Use separate mains systems for each power supply whenever it is possible.

(a) Observe the temperature derating requirements of [Figure 35](#) and [Figure 36](#) for n+1 redundancy applications.

Operation on Two Phases

The power supply can also be used on two-phases of a three-phase-system. Such a phase-to-phase connection is allowed as long as the supplying voltage is below $240V+10\%$.

The maximum allowed voltage between a Phase and the PE must be below 300V AC.

Figure 39 - Operation on Two Phases

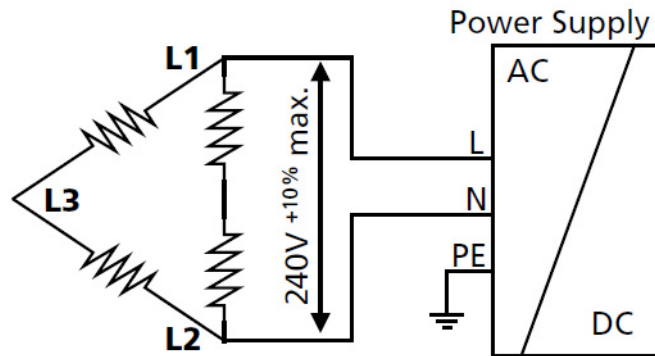

Use in a Tightly Sealed Enclosure

When the power supply is installed in a tightly sealed enclosure, the temperature inside the enclosure will be higher than outside. In such situations, the inside temperature defines the ambient temperature for the power supply.

The following measurement results can be used as a reference to estimate the temperature rise inside the enclosure.

The power supply is placed in the middle of the box, no other heat producing items are inside the box.

Attribute	Value
Enclosure	Rittal Typ IP66 Box PK 9519 100, plastic, 180x180x165mm
Load	24V, 16 A; (=80%) load is placed outside the box
Input	230V AC
Temperature inside enclosure	51.9 °C (125.4 °F) (in the middle of the right side of the power supply with a distance of 2 cm)
Temperature outside enclosure	25.6 °C (78.1 °F)
Temperature rise	26.3 K

Mounting Orientations

Mounting orientations other than all terminals on the bottom require a reduction in continuous output power or a limitation in the maximum allowed ambient temperature. The amount of reduction influences the lifetime expectancy of the power supply. Therefore, two different derating curves for continuous operation can be found below:

- Curve A1: Recommended output current.
- Curve A2: Max allowed output current (results in approximately half the lifetime expectancy of A1).

Figure 40 - Mounting Orientation A (Standard Orientation)

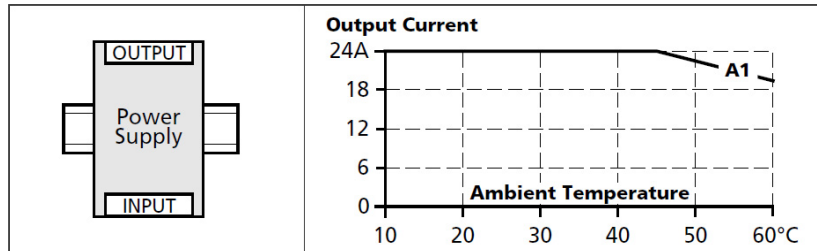

Figure 41 - Mounting Orientation B (Upside Down)

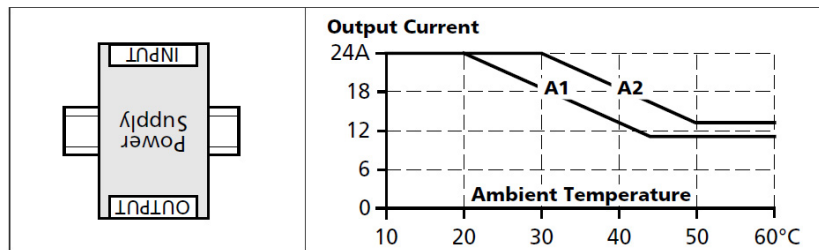

Figure 42 - Mounting Orientation C (Table-top Mounting)

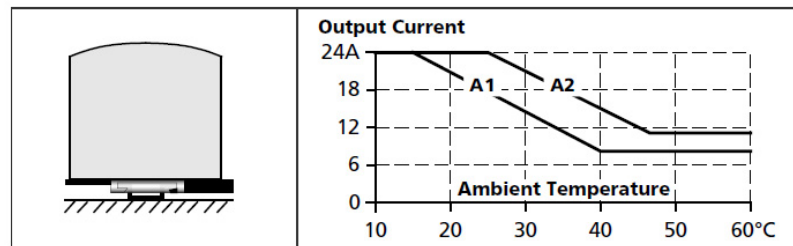

Figure 43 - Mounting Orientation D (Horizontal CW - Input on the Left)

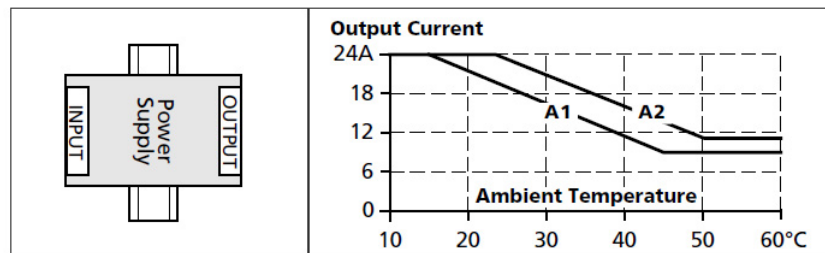
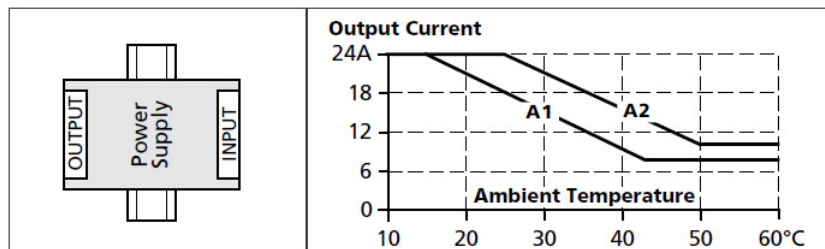

Figure 44 - Mounting Orientation E (Horizontal CCW - Input on the Right)



Additional Resources

These documents contain additional information concerning related products from Rockwell Automation.

Resource	Description
Power Supply Technical Data, publication 1606-TD002 .	Provides product selection, specifications, and dimensions information.
Industrial Components Preventive Maintenance, Enclosures, and Contact Ratings Specifications, publication IC-TD002	Provides a quick reference tool for Allen-Bradley industrial automation controls and assemblies.
Safety Guidelines for the Application, Installation, and Maintenance of Solid-state Control, publication SGI-1.1	Designed to harmonize with NEMA Standards Publication No. ICS 1.1-1987 and provides general guidelines for the application, installation, and maintenance of solid-state control in the form of individual devices or packaged assemblies incorporating solid-state components.
Industrial Automation Wiring and Grounding Guidelines, publication 1770-4.1	Provides general guidelines for installing a Rockwell Automation industrial system.
Product Certifications website, rok.auto/certifications .	Provides declarations of conformity, certificates, and other certification details.

You can view or download publications at rok.auto/literature.

Rockwell Automation Support

Use these resources to access support information.

Technical Support Center	Find help with how-to videos, FAQs, chat, user forums, and product notification updates.	rok.auto/support
Knowledgebase	Access Knowledgebase articles.	rok.auto/knowledgebase
Local Technical Support Phone Numbers	Locate the telephone number for your country.	rok.auto/phonesupport
Literature Library	Find installation instructions, manuals, brochures, and technical data publications.	rok.auto/literature
Product Compatibility and Download Center (PCDC)	Download firmware, associated files (such as AOP, EDS, and DTM), and access product release notes.	rok.auto/pcdc

Documentation Feedback

Your comments help us serve your documentation needs better. If you have any suggestions on how to improve our content, complete the form at rok.auto/docfeedback.

Waste Electrical and Electronic Equipment (WEEE)



At the end of life, this equipment should be collected separately from any unsorted municipal waste.





Rockwell Automation maintains current product environmental information on its website at rok.auto/pec.

Allen-Bradley, expanding human possibility, FactoryTalk, and Rockwell Automation are trademarks of Rockwell Automation, Inc.

EtherNet/IP is a trademark of ODVA, Inc.

Trademarks not belonging to Rockwell Automation are property of their respective companies.

Rockwell Otomasyon Ticaret A.Ş. Kar Plaza İş Merkezi E Blok Kat:6 34752, İçerenköy, İstanbul, Tel: +90 (216) 5698400 EEE Yönetmeliğine Uygundur

Connect with us.    

rockwellautomation.com ————— expanding **human possibility**[™]

AMERICAS: Rockwell Automation, 1201 South Second Street, Milwaukee, WI 53204-2496 USA, Tel: (1) 414.382.2000, Fax: (1) 414.382.4444

EUROPE/MIDDLE EAST/AFRICA: Rockwell Automation NV, Pegasus Park, De Kleetlaan 12a, 1831 Diegem, Belgium, Tel: (32) 2 663 0600, Fax: (32) 2 663 0640

ASIA PACIFIC: Rockwell Automation, Level 14, Core F, Cyberport 3, 100 Cyberport Road, Hong Kong, Tel: (852) 2887 4788, Fax: (852) 2508 1846