



Ultra1500 Digital Drives

(Catalog Numbers 2092-DA1, 2092-DA2, 2092-DA3, 2092-DA4, and 2092-DA5)

This Quick Start guide provides the basic information for installing and verifying the operational status of an Ultra1500™ with a compatible motor. This Quick Start is intended for qualified drive service personnel only.

For detailed and application related information about Ultra1500 drives, refer to the on-line help provided with v1.60 or higher of Ultraware™ software (catalog number 2098-UWCPG) and the *Ultra1500 Digital Drive User Manual* (publication 2092-UM001x-EN-E).

Set up your drive as easy as:

- Wire the drive.
- Configure using the Setup Wizard in Ultraware.
- Spin the motor.

Important User Information

Because of the variety of uses for the products described in this publication, those responsible for the application and use of this control equipment must satisfy themselves that all necessary steps have been taken to assure that each application and use meets all performance and safety requirements, including any applicable laws, regulations, codes and standards.

The illustrations, charts, sample programs and layout examples shown in this guide are intended solely for purposes of example. Since there are many variables and requirements associated with any particular installation, Allen-Bradley® does not assume responsibility or liability (to include intellectual property liability) for actual use based upon the examples shown in this publication.

Allen-Bradley publication SGI-IN001A-EN-P, *Safety Guidelines for the Application, Installation and Maintenance of Solid-State Control* (available from your local Allen-Bradley office), describes some important differences between solid-state equipment and electromechanical devices that should be taken into consideration when applying products such as those described in this publication.

Unpacking Your Ultra1500 Digital Drive

The box contains the following:

- One Ultra1500 drive (catalog numbers are listed above),
- Three removable plugs mounted on the power connectors of the drive,
- One connector tool for opening wire clamps on power connectors, and
- This Quick Start document.

Installation Checklist

Always adhere to the following installation guidelines:

Mechanical Checklist

- The ambient temperature of the drive must be in the range of 0°C to 50°C (32°F to 122°F).
- The air should be free of oil, corrosives, or electrically conductive contaminants.
- The humidity of the drive environment must not exceed 95%, and water must never condense on the drive.
- Ensure that adequate clearances are present above, below, and at the sides of the drive for ventilation (see Figure 1). Allow adequate clearance in front for proper cable bend radius.
- Size the drive enclosure adequately to properly manage the ambient temperature, after taking the drive power dissipation into consideration.
- Implementation of safety circuits and risk assessment is the responsibility of the machine builder.

Electrical Checklist

- Follow all applicable local codes and regulations to safely ground your system.
- Separate AC input power wiring and motor power cables from other control and motor feedback cables.
- When using transformer isolation of the input power, the secondary must be grounded. Transformers must be sized at double the sum of the output power of each axis.
- The electronic equipment, enclosure, machine frame, and motor housing should all be electrically bonded at high frequencies. Heavy braid wire should be used when mechanical bonding is not possible.
- In applications that repeatedly apply and remove main AC power to the drive, ensure that the cycling rate of the drive is not exceeded.
- AC line filters are recommended and should be located as close to the drive as possible.

Figure 1
Clearance Requirements for 2092 Drives

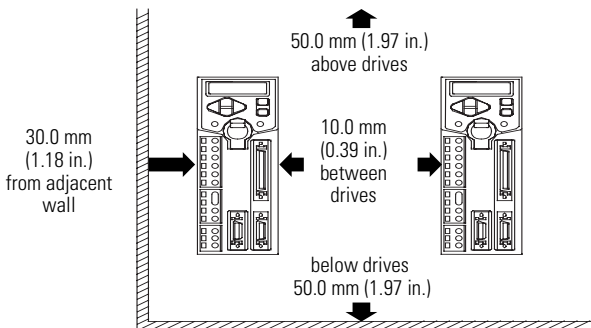

Drive Dimensions and Mounting Locations

Drive dimensions are shown in the following diagrams. Clearance requirements are shown on page 2.

Figure 2
Dimensional Outline Drawing for 2092-DA1 and 2092-DA2

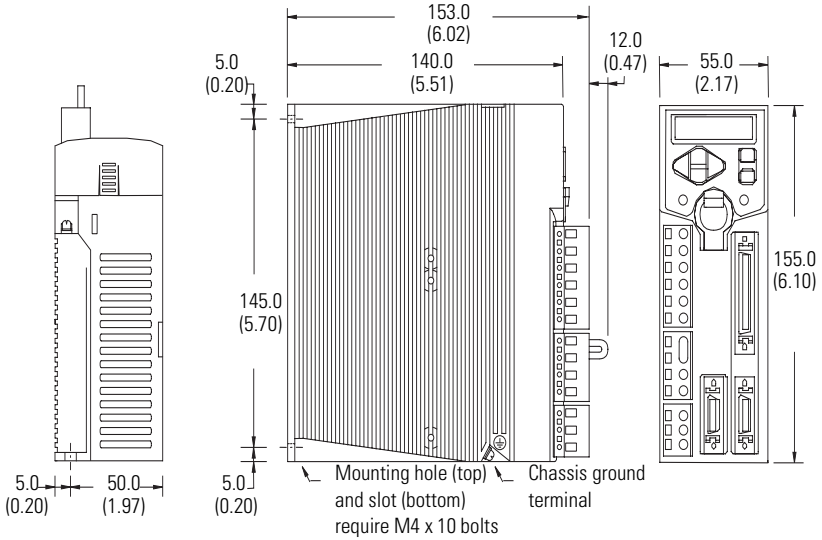

Dimensions are in millimeters (inches). Drives are designed to metric dimensions; inches are mathematical conversion.

Figure 3
Dimensional Outline Drawing for 2092-DA3

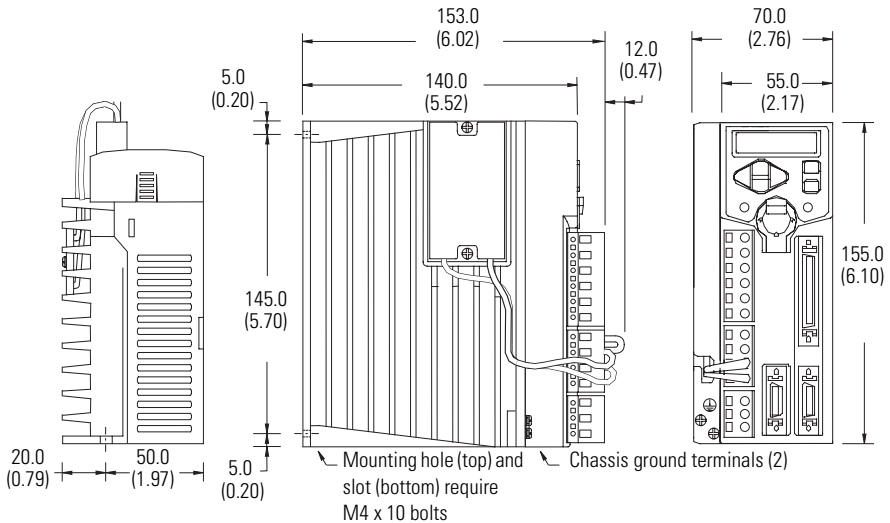

Dimensions are in millimeters (inches). Drives are designed to metric dimensions; inches are a mathematical conversion.

Figure 4
Dimensional Outline Drawing for 2092-DA4 and 2092-DA5

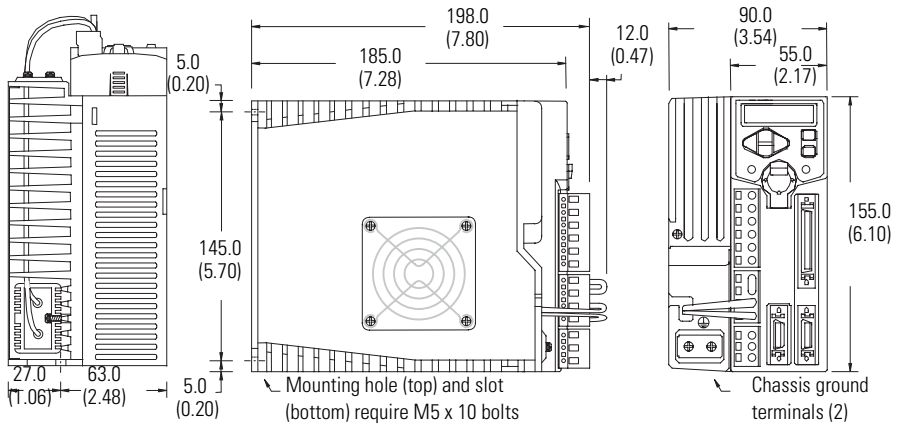

Dimensions are in millimeters (inches). Drives are designed to metric dimensions; inches are a mathematical conversion.

Power Wiring Diagram

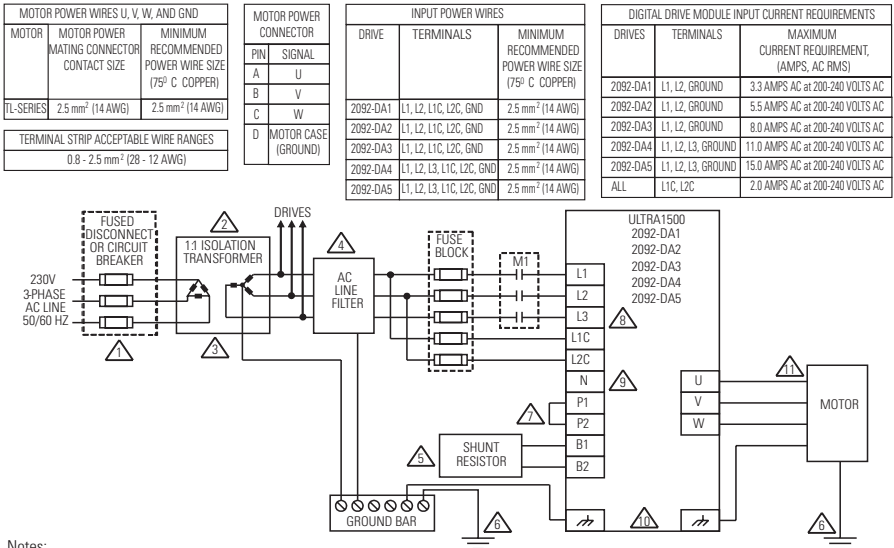

Notes:

1. A safety disconnecting device is required for maintenance and safety. Local regulations should be observed.
2. If using an isolation transformer, ensure the phase to neutral/ground voltage does not exceed the input ratings of the drive.
3. Isolation transformer is optional. If used, the secondary of the transformer must be grounded.
4. AC line filter and shielded motor cable are to be used for improving the drive module's electromagnetic compatibility (EMC), and are required to meet European EMC directive. CAUTION: AC line filters have large leakage currents and require discharge time upon power removal.
5. Wiring between the drive module and filter should be kept as short as possible. The common ground bus bar should be as close to the drive as possible.
6. Internal shunt resistor is present only on 2092-DA3, 2092-DA4, and 2092-DA5 drives. B1 and B2 should be left disconnected on 2092-DA1 and 2092-DA2 drives.
7. High-frequency grounding, using heavy braided wires, should connect together the electronic equipment, electrical enclosure, machine frame, and motor housing.
8. If the power factor or harmonic distortion needs improvement, the jumper from P1 to P2 can be replaced with an inductor.
9. 2092-DA1, 2092-DA2, and 2092-DA3 drives are single-phase AC input drives; input power is not connected to L3 on these drives.
10. DC Bus Voltage connection - not an AC power input.
11. 2092-DA1 and 2092-DA2 drives have one grounding screw on the heatsink. 2092-DA3, 2092-DA4, and 2092-DA5 drives have two grounding screws on the heatsink. Tighten the ground terminal screw(s) to 1.25 Nm (11 lbs-in.)
12. Refer to manual included with motor for power, feedback, and brake interconnect information (pinouts and/or wire colors).
13. Wire sizes are minimum recommended values. Local regulations should be observed.

I/O Interface Diagram

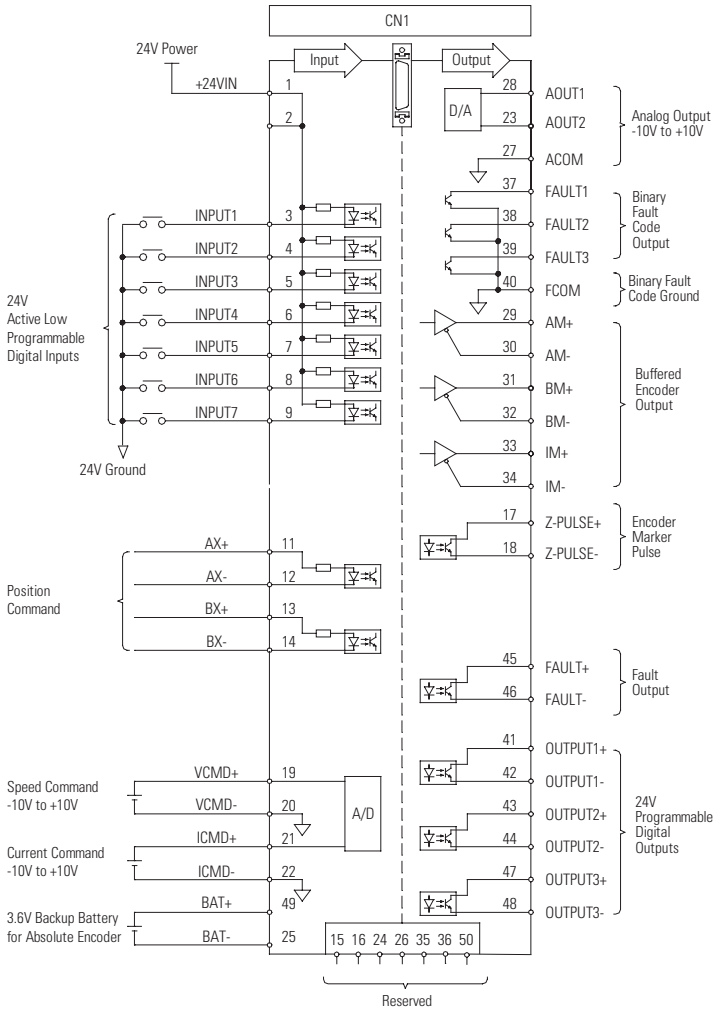

Drive Setup

The Setup Wizard found in the Commands menu of Ultraware software (v1.60 or higher) is a quick way to configure your Ultra1500 servo system. A step-by-step procedure assists in the selection of controls and motor to be configured with the Ultra1500 drive, and then tunes the assembled system.

For detailed hardware, interconnect, and application related information about Ultra1500 drives, refer to the following:

- The on-line help provided with Ultraware software, v1.60 or higher (catalog no. 2098-UWCPG).
- The *Ultra1500 Digital Drive User Manual* (publication 2092-UM001x-EN-E).

Figure 5
Ultra1500 Front Panel Display and Connections

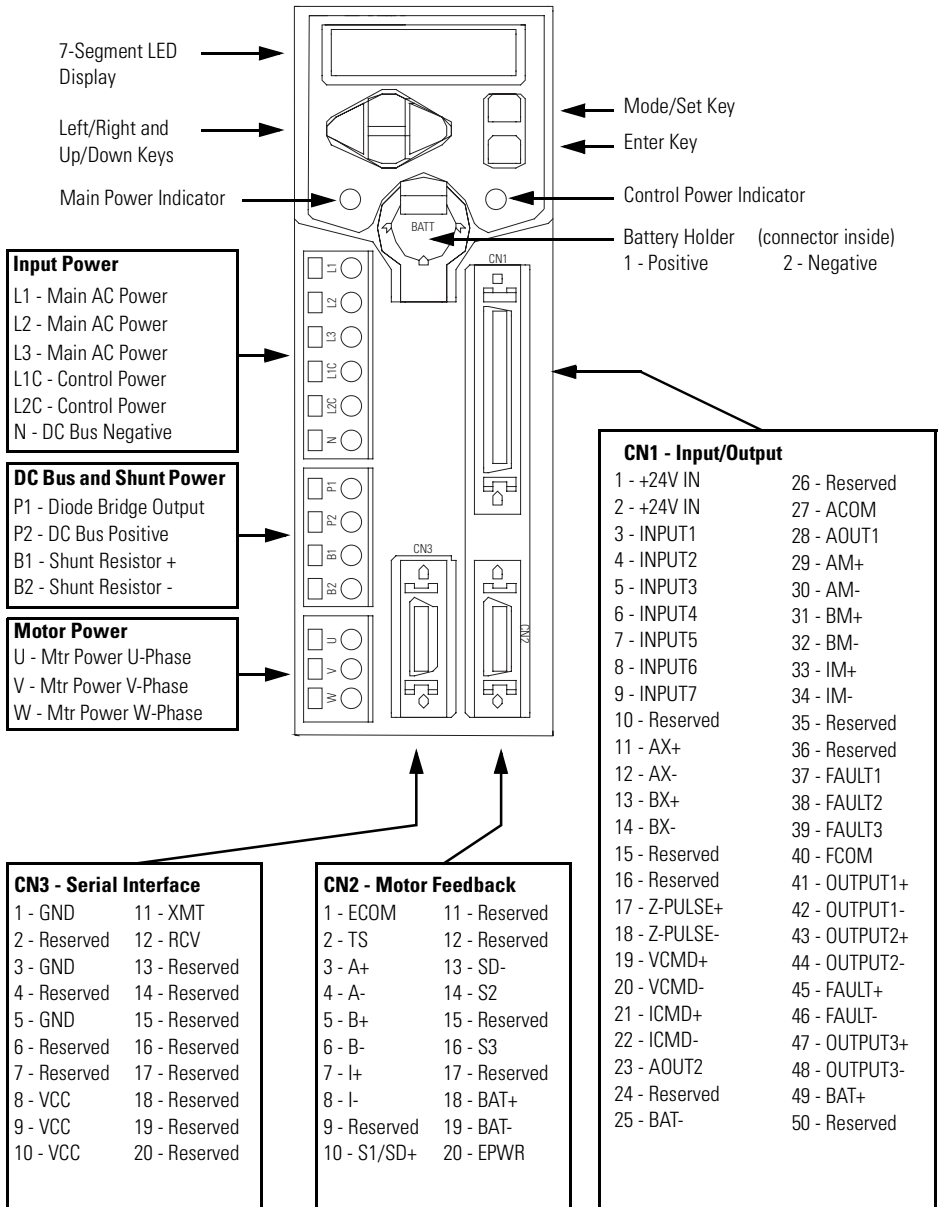

Mating Connectors

Connector	Type	Wire Size	A-B Connector Kit or Manufacturer P/N
Input Power	Single-row, spring clamp connectors with 7.5 mm spacing	2.5 - 0.8 mm ² (12 - 28 AWG) 8 mm (0.3 in.) of wire exposed	Wago 231-206/026-000 ¹
DC Bus and Shunt Power			Wago 231-204/026-000 ¹
Output (Motor) Power			Wago 231-203/026-000 ¹
CN1 - Input/Output	50-pin mini-D	0.2 mm ² (24 - 30 AWG)	9101-1476
CN2 - Motor Feedback	20-pin mini-D		9101-1477
CN3 - Serial Interface	20-pin mini-D		

¹ Tool (Wago 231-131) for opening individual cage clamps on above power connectors is supplied.

Drive Displays

The 7-segment display provides operational information when the drive is functioning, or warning/error messages when abnormalities are encountered.

Normal operational information consists of six characters that display data in three categories. The categories consist of a Control Mode (characters 0 and 1), a Row Display (2), and Status (3 to 5). Figure 6 depicts these categories and defines the information provided. Overtravel displays (see the table following Figure 6) occur if the drive detects an overtravel condition.

Figure 6
Operational Drive Displays

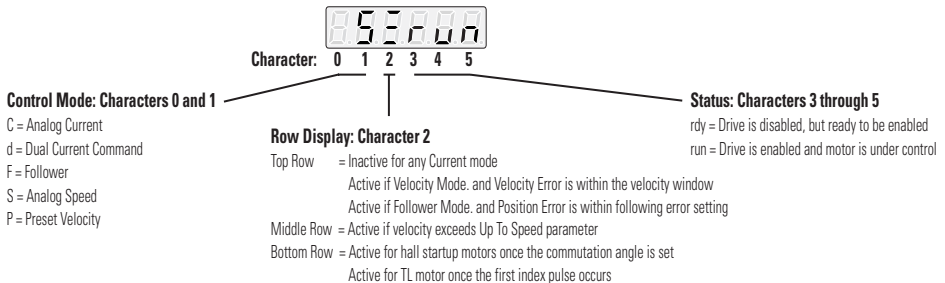

Overtravel Display	Possible Cause	Action/Solution
 Positive Overtravel	A Positive Overtravel condition is detected.	Apply motion in a negative direction to back off limit.
 Negative Overtravel	A Negative Overtravel condition is detected.	Apply motion in a positive direction to back off limit.

Warning and Error Displays

Warnings or errors are displayed by the drive as shown and explained in the following tables.

- Warnings are drive abnormalities that allow motor control to continue. The Warning display uses only the last three digits of the six-digit display.
- Errors are serious abnormalities that do not allow motor control. The Error display alternates between a three-digit error code and a six-digit text message.

Warning Display	Possible Cause	Action/Solution
Absolute Encoder Battery	3.2V or less output from encoder battery or external power supply.	Replace battery or verify external power supply. ¹
Power Up Overspeed	Control power is applied to the drive while the motor is in motion.	After verifying motor has stopped, recycle control power.
Over Current Command	Improper setting of analog current scale	Verify scaling parameter corresponds to analog signal range.
	System cannot meet motion profile	<ul style="list-style-type: none"> • Verify velocity loop tuning. • Verify system sizing.
	Incorrect current limit settings	Verify current limits do not restrict current to less than system capabilities.
Over Speed Command	Improper setting of analog velocity scale	Verify scaling parameter corresponds to analog signal range.
	System cannot meet motion profile	<ul style="list-style-type: none"> • Verify position loop tuning. • Verify system sizing.
Digital I/O Assignment	Inappropriate assignment of digital inputs or outputs	<ul style="list-style-type: none"> • If operated in preset mode, verify presets are assigned. • If operated in a normal/override mode, verify the override function is assigned.

¹ Battery replacement causes loss of absolute position. Homing may be necessary.

Error Code	Text Message	Possible Cause	Action/Solution
Motor Overtemperature		Motor thermal switch trips due to: <ul style="list-style-type: none"> • High motor ambient temperature, and/or • Excessive current 	<ul style="list-style-type: none"> • Operate within (not above) the continuous torque rating for the ambient temperature. • Lower ambient temperature, or increase motor cooling.
		Motor wiring error	Check motor wiring.
		Incorrect motor selection	Verify the proper motor has been selected.

Error Code	Text Message	Possible Cause	Action/Solution
E005 IPM Error	E1PnFE	Motor cables shorted	Verify continuity of motor power cable and connector.
		Motor winding shorted internally	Disconnect motor power cables from the motor. If the motor is difficult to turn by hand, it may need to be replaced.
		Drive temperature too high	<ul style="list-style-type: none"> Check for clogged vents or defective fan. Ensure cooling is not restricted by insufficient space around the drive.
		Operation above continuous power rating	<ul style="list-style-type: none"> Verify ambient temperature is not too high. Operate within the continuous power rating. Reduce acceleration rates.
		Drive has a bad IPM output, short circuit, or overcurrent	Remove all power and motors connections, then perform a continuity check from the DC bus to the U, V, and W motor terminals. If continuity exists, check for wire fibers between terminals, or send drive in for repair.
E009 Bus Undervoltage	E0UUE0	Low AC line/AC power input	<ul style="list-style-type: none"> Verify voltage level of the incoming AC power. Check AC power sources for glitches or line drop. Install uninterruptible power supply (UPS) on the AC input.
		Attempted to enable drive without main power active.	Apply main power before enabling drive.
E010 Bus Overvoltage	E0UUE0	Excessive regeneration of power (i.e., When the motor is driven by an external mechanical force, it may regenerate too much peak energy through the drive's power supply and the drive faults to save itself from an overload.)	<ul style="list-style-type: none"> Verify shunt circuit. Adjust motion profile to stay within the range of the regenerative resistor. Replace regenerative transistor. Replace drive.
		Excessive AC input voltage	Verify input is within specification.
E018 Motor Overspeed	E0U5PD	Motor speed exceeds maximum	<ul style="list-style-type: none"> Confirm encoder wiring. Retune drive system. Verify input gain of external speed or torque command.
E019 Excess Position Error	EP05EP	Position error exceeds permitted value	<ul style="list-style-type: none"> Increase following error limit. Check position loop tuning.
E022 Motor Continuous Current Overload	E0C0NL	The internal filter protecting the motor from overheating has tripped	<ul style="list-style-type: none"> Reduce acceleration rates. Reduce duty cycle (ON/OFF) of commanded motion. Increase time permitted for motion. Use larger drive and motor. Checking tuning.

Error Code	Text Message	Possible Cause	Action/Solution
E023	EdrvOVL Drive Overload	The motion application requires average drive current in excess of rated capability	<ul style="list-style-type: none"> Reduce acceleration rates. Reduce duty cycle (ON/OFF) of commanded motion. Increase time permitted for motion. Use larger drive and motor. Check tuning.
E028	EencRDE Encoder Data Range Error	Encoder not programmed correctly	Replace motor.
		Encoder memory corrupted	
E030	EencCOP Encoder Cable Open	Communication not established with an intelligent encoder.	<ul style="list-style-type: none"> Verify motor selection. Verify the motor supports automatic identification. Verify encoder wiring.
		Hall error	
E031	EencCPE Encoder Data Parameter Error	Encoder not programmed correctly	Replace motor.
		Encoder memory corrupted	
E036	EdrvOBT Drive Overtemperature	Excessive heat exists in the drive	<ul style="list-style-type: none"> Verify cooling fan operation (2092-DA4 and 2092-DA5 only). Check tuning. Reduce acceleration rate. Reduce duty cycle (ON/OFF) of commanded motion. Increase time permitted for motion. Use larger drive and motor.
E037	EACLF AC Line Loss	Poor quality power	Increase Ride Through time.
		Attempted to enable drive without main power active	Apply main power before enabling drive.
		Phase connection missing	Remove power and verify all physical connections.
		Fault Delay parameter is set too short	Increase the Fault Delay parameter setting.
E053	EPIInit User Parameter Initialization Error	Error in parameter memory storage	<ul style="list-style-type: none"> Reinitialize parameter. Reset drive to factory defaults.
E054	EofFSE Current Feedback Offset	Defective hardware	Replace drive.
E055	ECHSUM User Parameter Checksum Error	Checksum error	<ul style="list-style-type: none"> Confirm and reset parameter. Reset drive to factory defaults.
E056	ECPWFL Watchdog Timeout	Excessive system noise	Verify wiring and installation methods.
		Defective hardware	Replace drive.
E057	EHWPE PWM Hardware Error	Defective hardware	Contact A-B.

Error Code	Text Message	Possible Cause	Action/Solution
E058	ErRange User Parameter Range Error	Range of parameter is invalid	<ul style="list-style-type: none"> Enter parameter with value(s) within range. Reset drive to factory defaults.
E060	EdiInit Drive Initialization Error	Hardware error	Replace drive.
E075	ESHEOL Shunt Overload Protection	Power at regenerative resistor exceeds the permitted value	Adjust motion profile to stay within the range of the regenerative resistor.
		Shunt resistor is disconnected or damaged	<ul style="list-style-type: none"> Verify resistor connection. Verify resistance of shunt resistor.
E079	ESHEOL Shunt Overcurrent Protection	Shunt current exceeded allowable instantaneous value	<ul style="list-style-type: none"> Verify shunt is not shorted or damaged. Verify load energy is not excessive during deceleration.
E083	EAb5bE Absolute Encoder Battery Error	Encoder Backup Battery parameter is set to installed, but a battery is not installed.	Set Encoder Backup Battery parameter to Not Installed.
		Battery voltage is sensed below 2.7V dc.	<ul style="list-style-type: none"> Confirm battery voltage and connection. Replace battery.
E084	EAb5o5 Absolute Encoder Overspeed	Battery powered encoder is mechanically rotated at high speed while drive is powered down	<ul style="list-style-type: none"> Mechanically disengage motor from system. Cycle power to drive and reset alarm.
E085	EAb5cE Absolute Encoder Multi-turn Count Error	Noise in the encoder	Cycle power to drive and reset alarm.
		Defective encoder	Replace motor.
E086	EEn5cE Encoder Single-Turn Count Error	Noise in the encoder	Cycle power to drive and reset alarm.
		Defective encoder	Replace motor.
E100	ESSEUP Drive Set Up	The drive operating mode and motor selection are incompatible.	Change the operating mode and/or the motor selection, and reset the drive.
E101	ECABLE Motor Power Cable Open	Motor cable open	Verify power connection between motor and drive.
E102	E1a5oL Motor Instantaneous Current Overload	Motion profile requires a peak current for an excessive time interval	<ul style="list-style-type: none"> Verify motor wiring. Adjust accel/decel time. Confirm motor selection.
		Defective current feedback sensing	Verify phase currents.
E103	EAn5cH Motor Mismatch	Dynamic braking current of the selected motor exceeds twice the drive peak current rating	Install a different motor.

Error Code	Text Message	Possible Cause	Action/Solution
E10400	E.P.H.P.O.L. Continuous Power Overload	Motion application requires average drive power in excess of rated capability	<ul style="list-style-type: none"> • Reduce acceleration rates. • Reduce duty cycle (ON/OFF) of commanded motion. • Increase time permitted for motion. • Use larger drive and motor. • Check tuning.
E10500	E.E.N.C.P.P. Encoder Type Mismatch	Motor encoder signals do not match drive configuration	Verify motor selection.
E10600	E.E.R.C.C.C. Encoder Communication Error	Wiring between drive and encoder is faulty or disconnected, or EMI (noise) disrupts encoder signals.	<ul style="list-style-type: none"> • Verify encoder wiring. • Contact A-B.
E10700	E.S.E.F.C.C. Special Communication Error	Communications error between host and drive (noise)	<ul style="list-style-type: none"> • Verify serial cable. • Check for noise on serial interface.
E10800	E.C.H.F.P.P. Position Command Frequency Error	Input frequency limit exceeded	<ul style="list-style-type: none"> • Verify hardware type selected in the drive matches the physical hardware. • Change from open collector to line drive. • Reduce the speed command. • Apply gearing.

Drive Specifications

Drive	2092-DA1	2092-DA2	2092-DA3	2092-DA4	2092-DA5
Weight	0.9 kg (1.98 lbs)		1.2 kg (2.65 lbs)	2.1 kg (4.63 lbs)	
Temperature	0° C to 50° C (32° F to 122° F)				
Operating Shock, and Vibration	15 G, Half Sine, 11 ms 5 – 500 Hz @ 2.5 G, 0.381 mm (0.015 in.) maximum displacement				
Short Circuit Current Rating with No Fuse Restrictions	Suitable for use on a circuit capable of delivering not more than 5000 rms symmetrical amperes, 240 Volts maximum.				
Short Circuit Current Rating with Fuse Restrictions	Suitable for use on a circuit capable of delivering not more than 200,000 rms symmetrical amperes, 240 Volts maximum, when protected by high interrupt capacity, current limiting fuses UL198C (Class CC, G, J, L, R, T).				
Motor Overload Protection	Utilizes solid state motor overload protection which operates: <ul style="list-style-type: none"> • within 8 minutes at 200% overload. • within 20 seconds at 600% overload 				
Symbols Used on Drive	Ⓧ Protective ground conductor terminal				
Certification and Compliance ¹	UL [®] listed to U.S. and Canadian safety standards (UL 508C File E145959) CE and C-Tick marked for all applicable directives				

Main Input Power

Nominal Input Voltage (V_{rms}) ^{2,3}	200-240V, 1 phase, 50 or 60 Hz			200- 240V, 3 phase, 50 or 60 Hz	
Input Current (A_{rms})	3.3A	5.5A	8.0A	11.0A	15.0A
Maximum Inrush Current (0-peak)	200A				
Maximum Power Cycles/Minute	1 power cycle/2 minute interval				
DC Bus Discharge Time	3 minutes after removal of main AC power				

Control Input Power

Input Voltage (V_{rms}) ^{2,3}	200-240V, 1 phase, 50/60 Hz				
Input Current (A_{rms})	2.0A				
Maximum Inrush Current (0-peak)	75A				

Motor Output

Continuous Output Current (0-peak)	1.4A	2.4A	4.7A	10.7A	16.4A
Intermittent Output Current (0-peak)	3.4A	7.2A	11.3A	24.8A	43.4A
Continuous Output Power @ 240V _{ac}	400W	650W	1000W	3000W	4000W

Power Dissipation

Maximum Power Dissipation	50W	50W	50W +30W ⁴	100W+50W ⁴	150W+70W ⁴
---------------------------	-----	-----	-----------------------	-----------------------	-----------------------

¹ Refer to www.ab.com/certification/ce/doc for more information.

² Nominal values are listed. Absolute range is 180 to 264 V_{rms} .

³ The AC input voltage between any two input power pins (L1, L2, L3, L1C, L2C, and CHASSIS) must not exceed this rating. This note also applies to the CHASSIS ground connection, which implies that transformer secondaries must be grounded.

⁴ Maximum Power Dissipation includes dissipative power of drive plus the Continuous Shunt Power rating of the drive's internal shunt.

Drive	2092-DA1	2092-DA2	2092-DA3	2092-DA4	2092-DA5
-------	----------	----------	----------	----------	----------

Internal Shunt Power

Continuous Shunt Power	–	–	30W	50W	70W
Instantaneous Shunt Power	–	–	3000W	3000W	5000W

Digital Input/Output Specifications

Type	Active Low, current sinking
External Power Supply Requirements	Voltage: 21.6V to 26.4V Maximum Current Draw: 64 mA Note: Digital I/O is not powered by an internal supply, customer must connect an external power supply.

Analog Input/Output Specifications

Inputs	Voltage range is -10V to +10V Impedance of 10 k Ω . A/D conversion with 16-bit resolution
Outputs	Voltage range -10V to +10V Current output of up to 10 mA into a resistive load D/A conversion with 12-bit resolution

Motor Control Specifications

Feedback Device Power	5V supplied by drive for incremental and serial encoder devices.
Incremental Encoder Requirements	Differential drivers for A, B, Z, and single-ended Hall signals S1, S2, and S3 Maximum line frequency: 4,000,000 lines/second (16,000,000 counts second)

Fuse and Contactor Recommendations

Main Power Fuses ¹	2092-DA1	2092-DA2	2092-DA3	2092-DA4	2092-DA5
Recommended Fuse Group 1 ²	FNQ-R-7		FNQ-R-10	FNQ-R-15	FNQ-R-20
Recommended Fuse Group 2 ³	NA			LPJ-15	LPJ-20

Control Power Fuses ¹

Recommended Fuse Group 1 ⁴	FRS-R-2-1/2
Recommended Fuse Group 2 ²	FNQ-R-7-1/2
Recommended Fuse Group 3 ³	LPJ-6

Contactor ⁵	100-M05N _{xy}	100-M09N _{xy}	100-M12N _{xy}	100-C16 _{xy}	100-C23 _{xy}
------------------------	------------------------	------------------------	------------------------	-----------------------	-----------------------

¹ Fuses specified are Bussmann® fuses.

² FNQ-R fuses are described as Time-Delay Fuses, Class CC.

³ LPJ fuses are described as Dual-Element Time-Delay Fuses, Class J.

⁴ FRS-R fuses are described as Dual-Element Time-Delay Fuses, Class RK5.

⁵ For contactors: x represents coil voltage, and y represents number of contacts.

Accessories

Catalog Number or Item	Description and/or Specifications				
2090-DA-BAT	3.6V Battery with connector (for multi-turn encoder)				
AC Line Filters	2092-DA1	2092-DA2	2092-DA3	2092-DA4	2092-DA5
	2090-UXLF-106		2090-UXLF-110	2090-UXLF-HV323	
Connector Kits					
9101-1476	50 pin Mini-D Connector Kit (solder cup type) for CN1				
9101-1477	20 pin Mini-D Connector Kit (solder cup type) for CN2 and CN3				
Cables					
2090-DANFCT-Sxx ¹	Feedback Cable for TL-Series Motors, connectors both ends				
2090-DANBT-18Sxx ¹	Brake Cable for TL-Series Motors, ring lugs to drive				
2090-DANPT-16Sxx ¹	Power Cable for TL-Series Motors, ferruled leads to drive				
2090-DAIO-D50xx ¹	CN1 Control Cable, connector to drive, flying leads to controller				
2090-DAPC-D09xx ¹	PC Cable, connectors both ends				

¹ Cable length (xx) is specified in meters: xx = 01, 03, 09, etc. Consult *Motion Control Selection Guide* (GMC-SG001.x-EN-P) for available lengths.

Related Documentation

These publications provide additional information; specifically about Rockwell Automation drives. To obtain a copy, contact your local Rockwell Automation office or distributor, or access the documents on-line at www.rockwellautomation.com/literature.

For information about:	Read this document:	Publication Number
Ultra1500 drive configuration and operation	<i>Ultra1500 Digital Drive User Manual</i>	2092-UM001x-EN-E
Programming motion using Ultra1500 drives	Help files for v1.6 or higher of Ultraware	Ultraware CD (Ctlg. No. 2098-UWCPG)
A glossary of industrial automation terms and abbreviations	Allen-Bradley <i>Industrial Automation Glossary</i>	AG-7.1
How to minimize and control system-level noise.	<i>System Design for Control of Electrical Noise Reference Manual</i>	GMC-RM001x-EN-P
An overview of Allen-Bradley motion controls and systems, including this and other products	<i>Motion Control Selection Guide</i>	GMC-SG001x-EN-P
General guidelines for personal safety in the application, installation, and maintenance of solid state controls	<i>Safety Guidelines for the Application, Installation and Maintenance of Solid-State Control</i>	SGI-IN001A-EN-P
An article on wire sizes and types for grounding electrical equipment	<i>National Electrical Code</i>	Published by the National Fire Protection Association of Boston, MA

For more information refer to our web site: www.ab.com/motion

For Rockwell Automation Technical Support information refer to: www.ab.com/support or Tel: (1) 440.646.5800

Allen-Bradley is a registered trademarks of Rockwell Automation, Inc.

Bussman is a registered trademark of Cooper Industries, Inc.

UL is a registered trademark of Underwriters Laboratories, Inc.

Ultra1500 and Ultraware are trademarks of Rockwell Automation, Inc.

www.rockwellautomation.com

Power, Control and Information Solutions Headquarters

Americas: Rockwell Automation, 1201 South Second Street, Milwaukee, WI 53204-2496 USA, Tel: (1) 414.382.2000, Fax: (1) 414.382.4444

Europe/Middle East/Africa: Rockwell Automation, Vorstlaan/Boulevard du Souverain 36, 1170 Brussels, Belgium, Tel: (32) 2 663 0600, Fax: (32) 2 663 0640

Asia Pacific: Rockwell Automation, Level 14, Core F, Cyberport 3, 100 Cyberport Road, Hong Kong, Tel: (852) 2887 4788, Fax: (852) 2508 1846

Publication 2092-QS001D-EN-P — July 2005

PN 0013-2066-004

Supersedes publication 2092-QA001C-EN-P — July 2004

Copyright © 2005 Rockwell Automation, Inc. All rights reserved. Printed in the USA.