



**ALLEN-BRADLEY**

# **Bulletin 1336VT Adjustable Frequency AC Drive**

Programming Manual



## Important User Information

Because of the variety of uses for this equipment and because of the differences between this solid-state equipment and electromechanical equipment, the user of and those responsible for applying this equipment must satisfy themselves as to the acceptability of each application and use of the equipment. In no event will Allen-Bradley Company be responsible or liable for indirect or consequential damages resulting from the use or application of this equipment. Study the safety information carefully, before beginning any procedure.

The illustrations shown in this manual are intended solely to illustrate the text of this manual. Because of the many variables and requirements associated with any particular installation, the Allen-Bradley Company cannot assume responsibility or liability for actual use based upon the illustrative uses and applications.

No patent liability is assumed by Allen-Bradley Company with respect to use of information, circuits or equipment described in this text.

Reproduction of the content of this manual, in whole or in part, without written permission of the Allen-Bradley Company is prohibited.

Throughout this manual we use notes to make you aware of safety considerations:



**ATTENTION:** Identifies information about practices or circumstances that can lead to personal injury or death, property damage or economic loss.

---

Attentions help you:

- Identify a hazard.
- Avoid the hazard.
- Recognize the consequences.

**Important:** Identifies information that is especially important for successful application and understanding of the product.



**Shock Hazard** labels may be located on or inside the drive to alert people that dangerous voltage may be present.

---

<b>Local Parameter Programming</b> .....	<b>1-1</b>
At all Programming and Display Panels, parameters 0-50 and 70-89 may be viewed (Read) while the drive is running. Eight of these parameters display real-time events (such as present drive speed and output current) that cannot be changed (Written to). The remaining parameters may be changed as long as the drive isn't running. A decimal point displayed in the far right corner indicates that programming has been selected and that the enter button has been pressed. Parameter values may be changed when the decimal point is present. With the exception of Parameter 45 (which is programmable in 0.01 kHz increments), all Programming and Display Panels allow all frequency parameters to be programmed in 0.1 Hertz increments and all time parameters to be programmed in 1 second increments. ....	1-1
Four pushbuttons on all Programming and Display Panels are used for both viewing and programming parameters. ....	1-1
The PR pushbutton is used to switch from the operating display to the parameter viewing display. Once in the viewing display, the PR pushbutton is used to increment through the parameters. ....	1-1
The Enter pushbutton is used to switch from viewing to programming but only when Parameter 0 is displayed, and only if switch SW1 is set to allow parameter programming. When programming parameters, the Enter pushbutton is also used to store the displayed value. .	1-1
These buttons are only functional in the programming mode. When programming parameters, the increment and decrement pushbuttons are used to scroll up or down to the parameter value to be entered. Pressing both buttons simultaneously will end programming and return the drive to the operating display. ....	1-1
After exiting the programming mode, the stop command must be cycled to reset the drive and confirm that programming is complete. Failure to follow these instructions will result in an F11 (Operator Error) fault. ....	1-1
SW1 is a rocker switch only accessible on the chassis mounted Local Programming and Display Panel. The switch can be accessed only with the drive cover removed and may be used to disable the Enter pushbutton and control access to local programming. ....	1-2

<b>Local and Serial Port Parameters</b> Firmware Version 1.01-3.01 .....	<b>3-1</b>
<b>Serial Port Parameters</b> Firmware Version 1.01-3.01 .....	<b>4-1</b>
<b>Local and Serial Port Parameters</b> Firmware Version 2.01-3.01 .....	<b>5-1</b>
<b>% Load/Current Conversion .....</b>	<b>7-1</b>
<b>% Power/kW Conversion .....</b>	<b>8-1</b>
<b>Local and Serial Port Parameter Settings</b> Firmware Version 1.01-3.01 .....	<b>9-1</b>
<b>Serial Port Parameter Settings</b> Firmware Version 1.01-3.01 .....	<b>10-1</b>
<b>Local and Serial Port Parameter Settings</b> Firmware Version 2.01 and 3.01 .....	<b>11-1</b>

## Manual Objective

The 1336VT Programming Manual is designed to be read and used like an ordinary textbook. Read the manual once from the beginning in the order presented to gain basic knowledge about your drive. Each chapter builds upon information presented in the previous chapter. Become familiar with tasks that must be performed in a sequence for safety and successful completion. To assure successful installation and operation, the material presented must be thoroughly read and understood before proceeding. Particular attention must be directed to the Attention and Important statements throughout the manual.

This manual defines the parameter and parameter values used in 1336VT drives with Main Control Board Firmware Version 1.01 to 2.01, and Base Driver/Power Supply Board Firmware Versions 1.01 to 3.01. At the back of this manual is a parameter setting chart that provides minimum and maximum parameter values, factory parameter settings, and a place to record any settings that were changed during programming. Also provided is a detailed Run and Start Boost setup procedure in Appendix A.

**Important:** Read and use the Hardware Manual first. Retain this manual for future reference.

**Important:** The Handheld Programming Terminal (Cat. No. 1336-MOD-E1) firmware must be upgraded with Kit SP-148340 (Version 2.01) to be compatible with drive firmware Version 2.01 and 3.01. The Monitor Display (Cat. No. 1336-MOD-E2) firmware must be upgraded with Kit SP-148341 (Version 2.01) to be compatible with drive firmware Version 2.01 and 3.01.

**Manual Objective (cont.)**

Firmware versions are marked at two locations in the drive – on the Main Control Board and on the Base Driver/Power Supply Board.

For all drive ratings, the microprocessor chip U14 located on the Main Control Board has the following firmware identification:

- P/N XXXXXXV1.01 — Firmware Version 1.01.
- P/N XXXXXXV1.10 — Firmware Version 2.01.

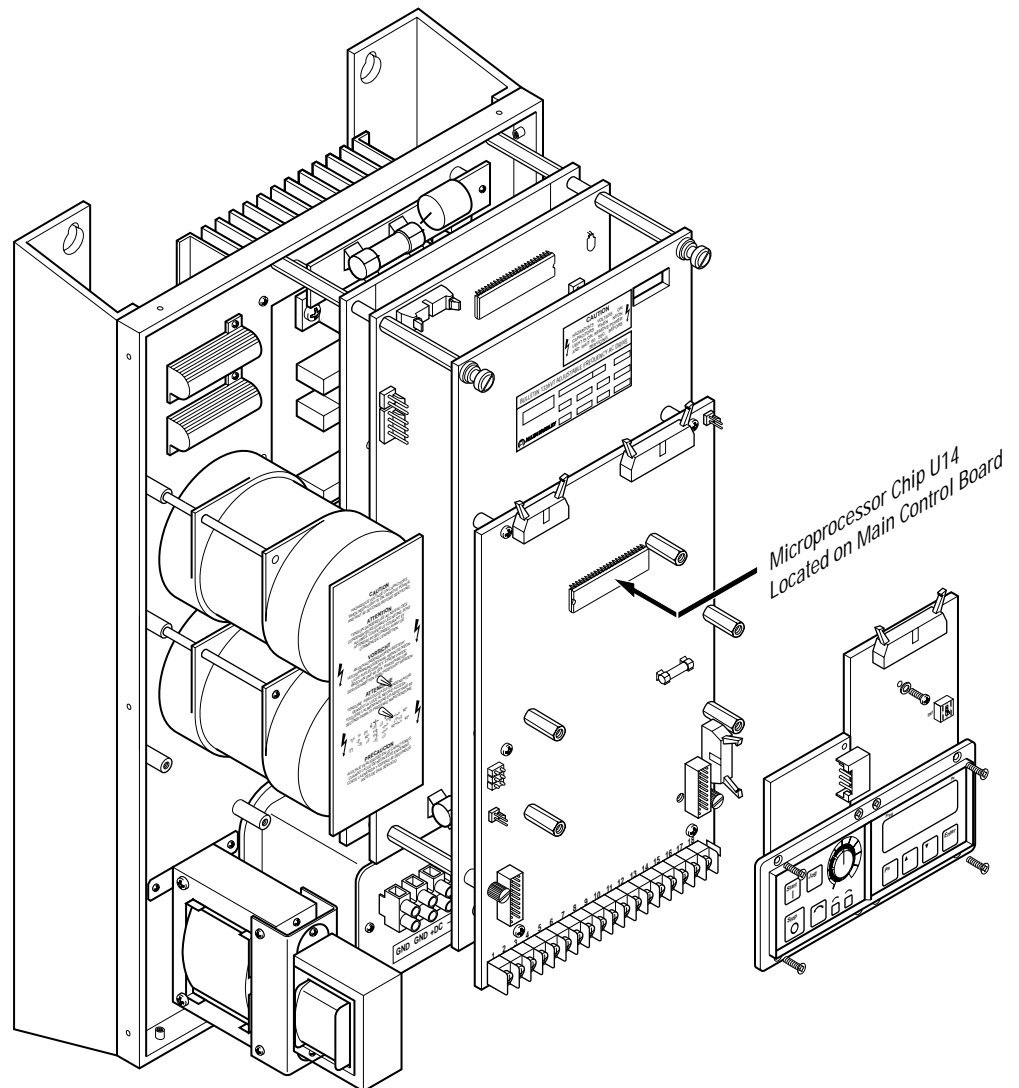

**Manual Objective (cont.)**

For 5-52 Amp ratings, microprocessor chip U21 located on the Base Driver/Power Supply Board has the following firmware identification:

- P/N XXXXXXV1.01 — Firmware Version 1.14.
- P/N XXXXXXV1.11 — Firmware Version 2.01.
- P/N XXXXXXV3.01 — Firmware Version 3.01.

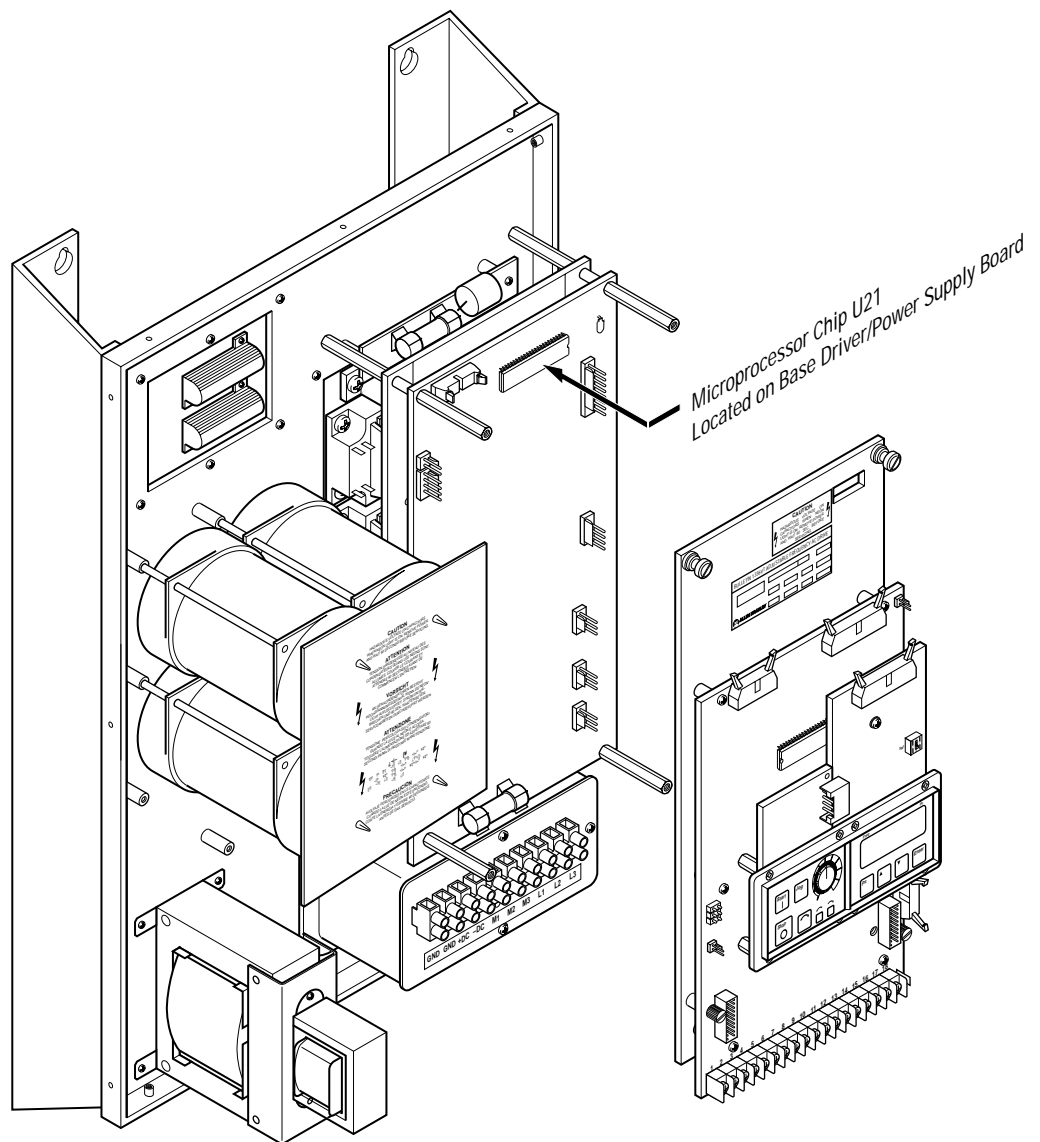

**Manual Objective (cont.)**

For 65-77 Amp ratings, microprocessor chip U2 located on the Base Driver/Power Supply Board has the following firmware identification:

- P/N XXXXXXV1.14 — Firmware Version 1.14.
- P/N XXXXXXV2.01 — Firmware Version 2.01.
- P/N XXXXXXV3.01 — Firmware Version 3.01.

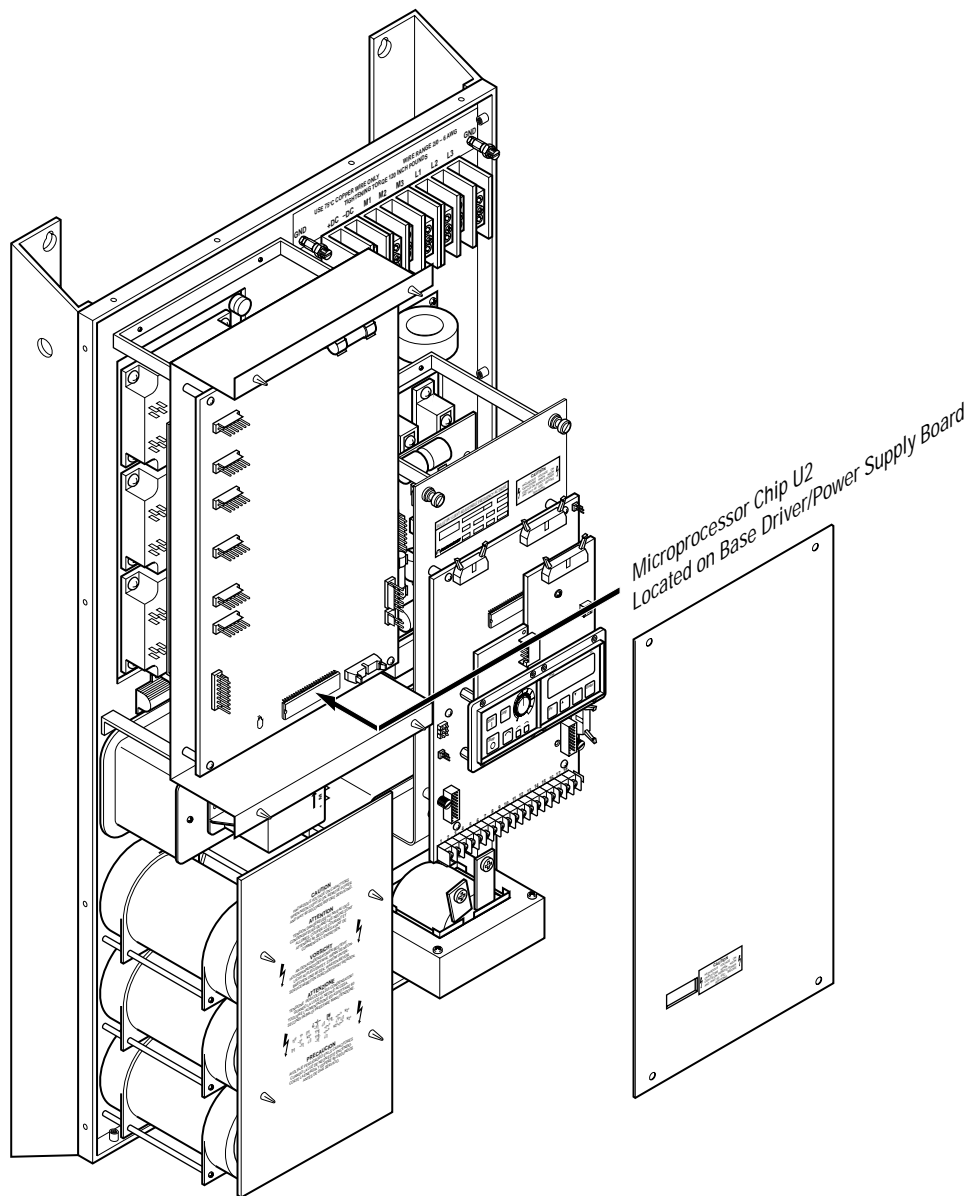

**Manual Objective (cont.)**

For 96-180 Amp ratings, microprocessor chip U2 located on the Base Driver/Power Supply Board has the following firmware identification:

- P/N XXXXXXV1.14 — Firmware Version 1.14.
- P/N XXXXXXV2.01 — Firmware Version 2.01.
- P/N XXXXXXV3.01 — Firmware Version 3.01.

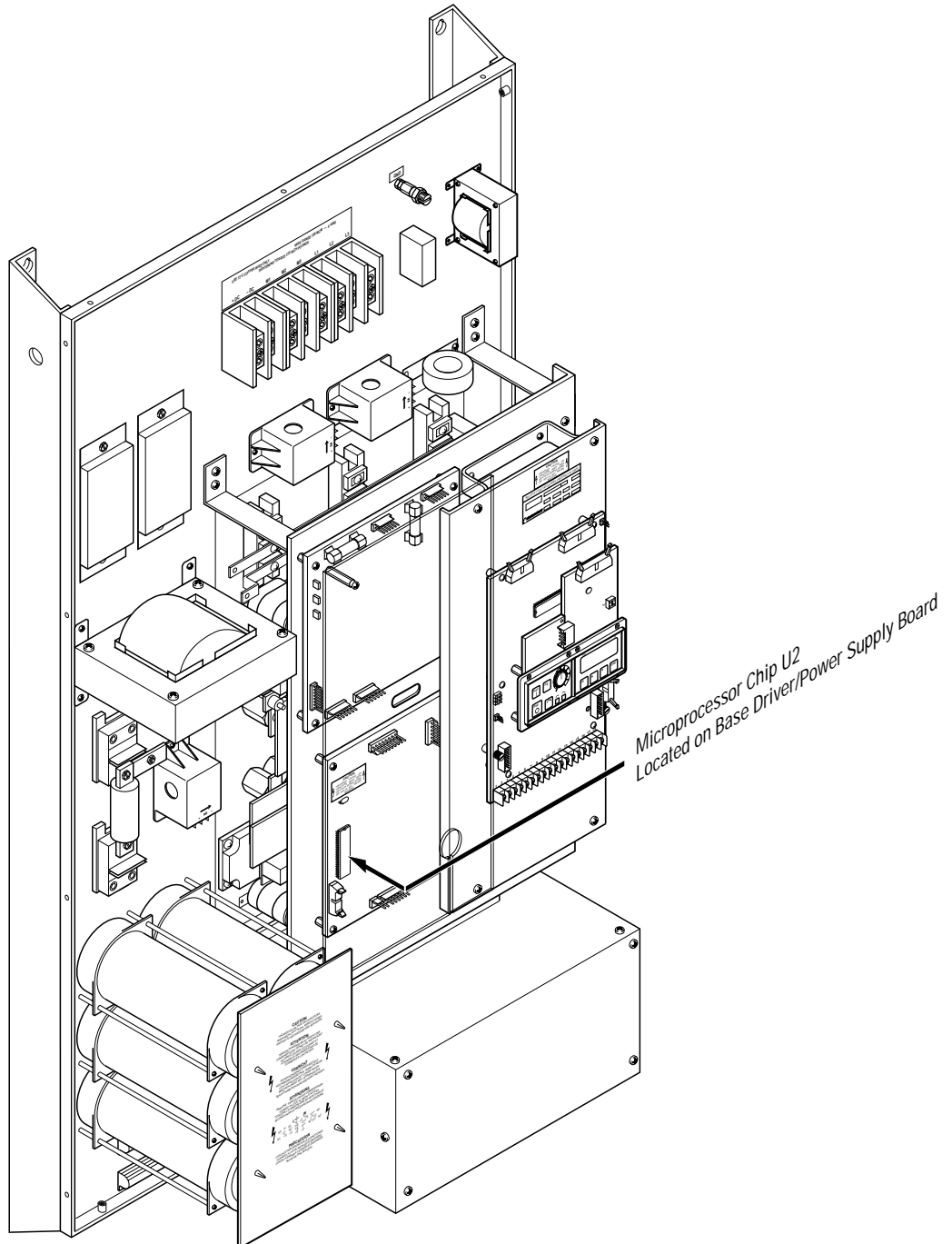

**Manual Objective (cont.)**

For 240-300 Amp ratings, microprocessor chip U2 located on the Base Driver/Power Supply Board has the following firmware identification:

- P/N XXXXXXV1.14 — Firmware Version 1.14.
- P/N XXXXXXV2.01 — Firmware Version 2.01.
- P/N XXXXXXV3.01 — Firmware Version 3.01.

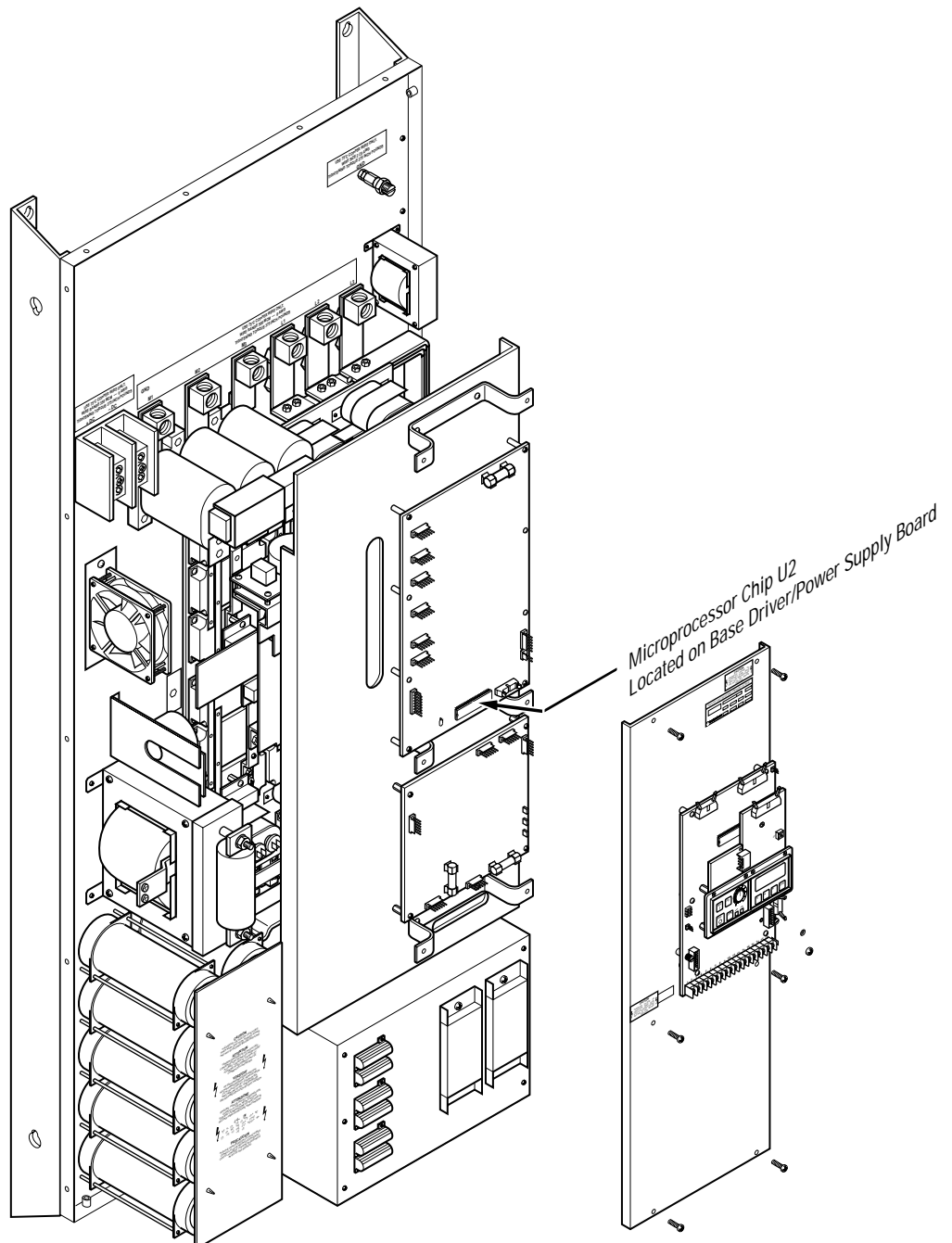

## Manual Objective (cont.)

This manual is meant to guide the user with interface, installation, setup and troubleshooting of a 1336VT. The contents are arranged in order from a general description to troubleshooting and maintenance. To assure successful installation and operation, the material presented must be thoroughly read and understood before proceeding. Particular attention must be directed to the Caution, Warning and Important statements contained within.

## Important Information about this Manual

This manual has been prepared primarily to support this product in a single application. It is a standard document that is intended to help the user understand the individual operating characteristics and limitations of this equipment including hazards associated with installation and setup procedures. Note the following points:

- This equipment has been designed to meet the requirements of a component in an integrated system.
- It must be noted that special considerations are to be given to characteristics of other peripheral solid-state control equipment and the cumulative impact on safety.
- Manufacturers and engineering groups responsible for specification or design of electrical control equipment must refer to applicable industry standards and codes for specific safety guidelines and interface requirements.
- In the actual factory environment, the user is responsible to assure compliance with applicable machine and operator safety codes or regulations which are beyond the scope and purpose of this document.

## General Precautions

In addition to the precautions listed throughout this manual, the following statements which are general to the system must be read and understood.



**ATTENTION:** Only personnel familiar with the 1336VT AC Drive and associated machinery should plan or implement the installation, start-up and subsequent maintenance of the system. Failure to comply may result in personal injury and/or equipment damage.



**ATTENTION:** An incorrectly applied or installed system can result in component damage or reduction in product life. Wiring or application errors, such as undersizing the motor, incorrect or inadequate AC supply, or excessive ambient temperatures may result in malfunction of the system.

---

## Local Parameter Programming

### Programming and Display Panel

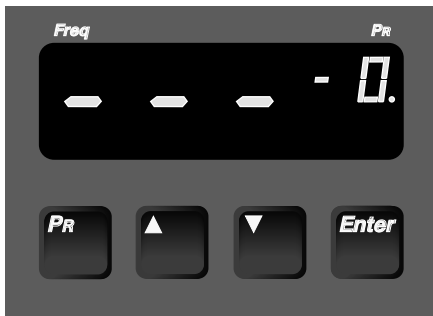

### Read and Write Restrictions

At all Programming and Display Panels, parameters 0-50 and 70-89 may be viewed (*Read*) while the drive is running. Eight of these parameters display real-time events (such as present drive speed and output current) that cannot be changed (*Written to*). The remaining parameters may be changed as long as the drive isn't running. A decimal point displayed in the far right corner indicates that programming has been selected and that the enter button has been pressed. Parameter values may be changed when the decimal point is present. With the exception of Parameter 45 (which is programmable in 0.01 kHz increments), all Programming and Display Panels allow all frequency parameters to be programmed in 0.1 Hertz increments and all time parameters to be programmed in 1 second increments.

Four pushbuttons on all Programming and Display Panels are used for both viewing and programming parameters.



The PR pushbutton is used to switch from the operating display to the parameter viewing display. Once in the viewing display, the PR pushbutton is used to increment through the parameters.



The Enter pushbutton is used to switch from viewing to programming but only when Parameter 0 is displayed, and only if switch SW1 is set to allow parameter programming. When programming parameters, the Enter pushbutton is also used to store the displayed value.



These buttons are only functional in the programming mode. When programming parameters, the increment and decrement pushbuttons are used to scroll up or down to the parameter value to be entered. Pressing both buttons simultaneously will end programming and return the drive to the operating display.

After exiting the programming mode, the stop command must be cycled to reset the drive and confirm that programming is complete. Failure to follow these instructions will result in an F11 (Operator Error) fault.

## SW1 Operation

SW1 is a rocker switch only accessible on the chassis mounted Local Programming and Display Panel. The switch can be accessed only with the drive cover removed and may be used to disable the Enter pushbutton and control access to local programming.

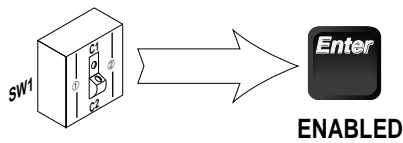

Enter button enabled — Access to programming allowed if SW1 is set to position C1.

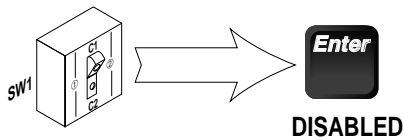

Enter button disabled — Access to programming not allowed if SW1 is set to position C2

## Serial Port Parameter Programming

### Read and Write Restrictions

Serial Port parameter programming may be accomplished by using the 1336-MOD-E1 or 1336-MOD-G2 through the 1336-MOD-S1 Serial Port Connector. Through the Serial Port Connector, all parameters may be viewed (Read) while the drive is running. Eight of these parameters display real-time events (such as present drive speed and output current) that cannot be changed (Written to). An additional 15 parameters are used to report drive status and operational codes that are not programmable. All remaining parameters may be changed while the drive is running. With the exception of Parameter 45 (which is programmable in 0.01 kHz increments), the Serial Port allows all frequency parameters to be programmed in 0.01 Hertz increments and all time parameters to be programmed in 0.01 second increments. Refer to your MOD option instructions for operation and setup.

## Local and Serial Port Parameters Firmware Version 1.01-3.01

The 1336VT drive logic uses a set of 90 user parameters to select and control drive operation. Seventy-one of these parameters are accessible through any of the Programming and Display Panels. All 90 are accessible through the Serial Port.

Initial values for each parameter have been preset at the factory and are shown in the following displays. Any interaction or preconditions required for setting parameters are included in the following descriptions.



When using any Programming and Display Panel, pressing the Enter pushbutton will access programming when parameter 0 is displayed. When using the chassis mounted Local Programming and Display Panel, switch SW1 on the panel must also be set to C1. In either case, in the programming mode a decimal point will be shown at the right edge of the display.



To store a changed value, the Enter pushbutton must be pressed first, if not, the previous value will be restored to memory.



To end programming, both the s t pushbuttons must be pressed and held down simultaneously.



After exiting the programming mode, the stop command must be cycled to reset the drive and confirm that programming is complete. The decimal point will not be displayed when not in the programming mode.

### Parameter 0 -- Parameter Mode

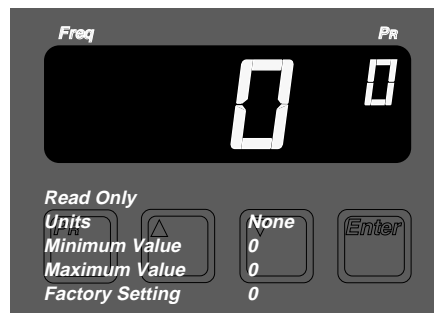

The first parameter displayed when either viewing or programming a parameter at a Programming and Display Panel.

### Parameter 1 -- Output Volts

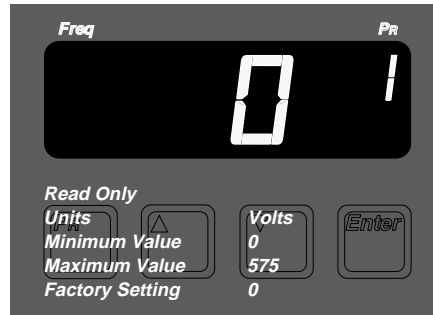

When this parameter is selected for viewing, the drive output voltage can be viewed while the drive is running.

### Parameter 2 — Output Current

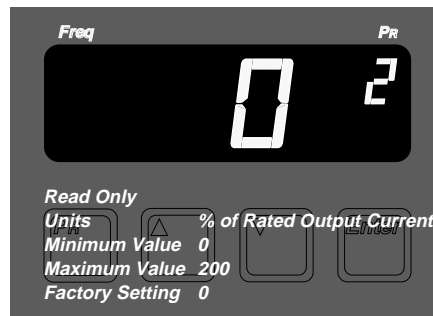

When this parameter is selected for viewing, the output current of the drive as a % of full load output current can be viewed while the drive is running. Refer to the % Load/Current Conversion Tables in Chapter 7 for quick conversions.

**Important:** The displayed output current is an approximate value calculated from drive internal calculations. Motor characteristics will affect the accuracy of the output current indication.

### Parameter 3 — Output Power

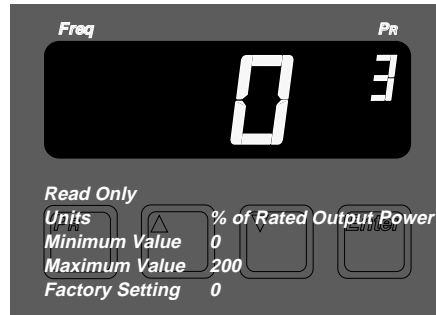

When this parameter is selected for viewing, the output power of the drive as a % of rated output power can be viewed while the drive is running. Refer to the % Power/HP Conversion Tables in Chapter 8, or the % Power/kW Conversion Tables in Chapter 9 for quick conversions.

**Important:** The displayed output current is an approximate value calculated from drive internal calculations. Motor characteristics will affect the accuracy of the output current indication.

### Parameter 4 -- Last Fault

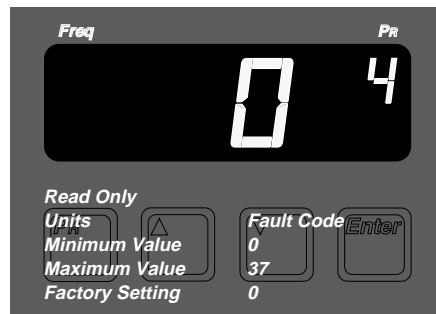

This parameter will always display the same value as shown in Parameter 86 even after the drive fault has been reset. Since Parameter displays 4 and 86 are identical but Parameter 86 is programmable, Parameter 4 will show whatever value has been entered in Parameter 86.

If a value has not been entered in Parameter 86, the Fault Code for the last drive fault that occurred will be shown. Both parameters are updated by the drive each time a new fault occurs. Refer to the 1336VT User Manual for Fault Code definitions.

## Parameter 5 — Frequency Select 1

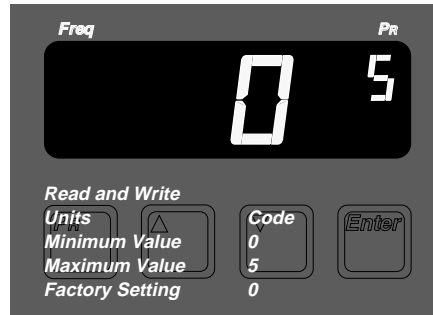

This parameter selects one of six possible sources to control drive output frequency when TB3 Terminal 27 is false. Either:

- 0** — A Control Panel speed potentiometer
- 1** — A 0 to +10V DC source at TB2
- 2** — A 4 to 20mA source at TB2
- 3** — A pulse train source at TB2
- 4** — A serial input source from 1336-MOD-G2 at the serial input port connector if 1336-MOD-S1 is installed.
- 5** — A remote speed potentiometer connected to TB2 Terminals 1, 2 & 3.

In addition to the selected parameter, other drive inputs may alter the source used for frequency control. Other sources include:

- Jog — Parameter 24
- Preset Frequency 1 — Parameter 27
- Preset Frequency 2 — Parameter 28
- Preset Frequency 3 — Parameter 29

This parameter may be programmed to only one of the six selectable values listed, **0** – **5**. Whenever Parameter 5 is selected, a value of **0** – **5** will be displayed. Since other sources can be the control source, the Operating Display however will always show the frequency source using the following code:

- 0** — Control Panel speed potentiometer
- 1** — 0 to +10V DC input
- 2** — 4 to 20mA input
- 3** — Pulse train input
- 4** — Serial input
- 5** — Remote speed pot input
- 6** — Jog
- 7** — Preset Frequency 1
- 8** — Preset Frequency 2
- 9** — Preset Speed 3 or if Parameter 72 is set to **1**, Preset Speeds 4-7.

Use the information provided in the 1336VT User Manual to determine what will be the drive speed source for various conditions.

## Parameter 6 — Frequency Select 2

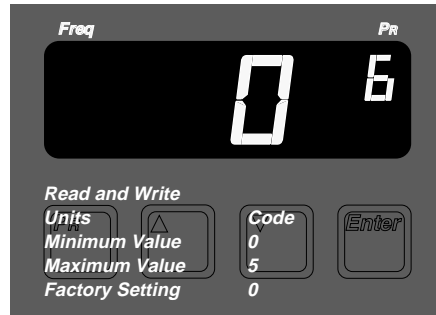

This parameter selects one of six possible sources to control the drive output frequency when Terminal 27 at TB3 is true. Either:

- 0** — A Control Panel speed potentiometer
- 1** — A 0 to +10V DC source at TB2
- 2** — A 4 to 20mA source at TB2
- 3** — A pulse train source at TB2
- 4** — A serial input source from 1336-MOD-G2 at the serial input port connector if 1336-MOD-S1 is installed.
- 5** — A remote speed potentiometer connected to TB2 Terminals 1, 2 & 3.

In addition to the selected parameter, other drive inputs may alter the source used for frequency control. Other sources include:

- Jog — Parameter 24
- Preset Frequency 1 — Parameter 27
- Preset Frequency 2 — Parameter 28
- Preset Frequency 3 — Parameter 29

This parameter may be programmed to only one of the six selectable values listed, **0** – **5**. Whenever Parameter 6 is selected, a value of **0** – **5** will be displayed. Since other sources can be the control source, the Operating Display however will always show the frequency source using the following code:

- 0** — Control Panel speed potentiometer
- 1** — 0 to +10V DC input
- 2** — 4 to 20mA input
- 3** — Pulse train input
- 4** — Serial input
- 5** — Remote speed pot input
- 6** — Jog
- 7** — Preset Frequency 1
- 8** — Preset Frequency 2
- 9** — Preset Speed 3 or if Parameter 72 is set to 1, Preset Speeds 4-7.

Use the information provided in the 1336VT Hardware User Manual to determine what will be the drive speed source for various conditions.

### Parameter 7 — Accel Time 1



This parameter determines the time that it will take the drive to ramp from 0 Hz to the maximum frequency programmed into Parameter 19. The drive output frequency will accelerate at a linear rate proportional to this setting for any frequency (speed) change unless one of the following conditions modify the rate:

Accel Time 2 is selected — see Parameter 30.

The MOPC setting is reached — see Parameter 36.

Dwell frequency is used — see Parameter 43.

### Parameter 8 — Decel Time 1



This parameter sets the time that it will take the drive to ramp from the maximum frequency programmed into Parameter 19 to 0 Hz. The drive output frequency will decelerate at a linear rate proportional to this setting for any frequency (speed) change unless one of the following conditions modify the rate:

Decel frequency hold is selected and a high bus voltage exists — see Parameter 11.

Decel time 2 is selected — see Parameter 31.

## Parameter 9 — DC Boost Select

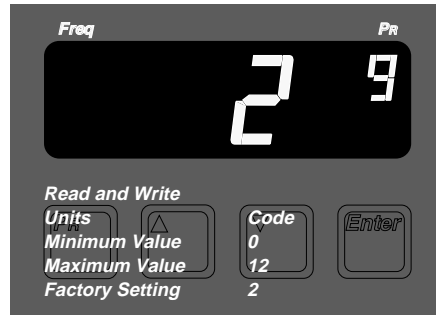

This parameter provides a selectable DC boost voltage to the motor at low drive frequency to allow the drive/motor combination to be adapted to various starting torque conditions. Usually increased starting torque requires more DC boost. High boost may produce unnecessary current at low frequency and contribute to motor overheating. Excessive boost may force the drive into MOPC resulting in poor drive performance. The optimum DC boost is the lowest level that will permit satisfactory starting torque in a properly sized motor and drive application.

Values **0** and **1** are especially reduced curves that also reduce the volts-per-hertz curve up to Base Frequency. These values are intended for use with drive/motor applications on fans and pumps where full rated motor torque is not required at reduced speeds.

Zero (**0**) produces zero boost at 0 Hz, and 30% of the Base Voltage set in Parameter 18 at 50% of the Base Frequency set in Parameter 17.

One (**1**) produces zero boost at 0 Hz, and 42% of the Base Voltage set in Parameter 18 at 50% of the Base Frequency set in Parameter 17.

Values **2** through **10** produce increasingly higher DC boost until the straight line volts-per-hertz curve set by Parameter 17 and 18 equals the set Boost Voltage.

- 2** = 0V DC boost
- 3** = 6V DC boost
- 4** = 12V DC boost
- 5** = 18V DC boost
- 6** = 24V DC boost
- 7** = 30V DC boost
- 8** = 36V DC boost
- 9** = 42V DC boost
- 10** = 48V DC boost

**11** is a custom volts-per-hertz and DC boost mode that uses Parameters 48, 49 and 50. Refer to these parameters for additional details.

**12** is also a custom volts-per-hertz and DC boost mode that uses Parameters 48 and 83. Refer to these parameters for additional details.

## Parameter 10 -- Stop Select

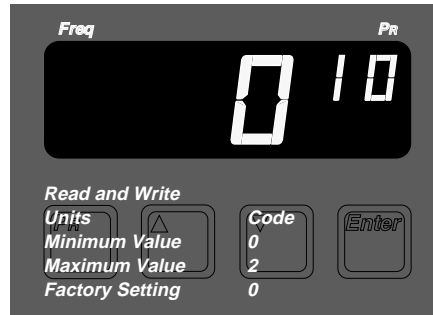

This parameter selects the stopping performance of the motor.

Zero (0) = coast-to-stop. The drive will shut off output frequency on receiving a Stop command to allow the motor to coast-to-stop. Set Parameter 12 to 0 seconds and Parameter 13 to 0 volts when Parameter 10 is set to 0.

One (1) = DC brake-to-stop. The drive will stop producing frequency on receiving a Stop Command and apply a DC Hold Voltage to the motor to reduce stopping time. The applied voltage and time of the DC brake action is set by DC hold Parameters 12 and 13. Excessive voltage may produce a motor current that exceeds the setting of Parameter 36, MOPC. Parameter 36 does not limit this current. If the drive is restarted after the DC Hold Time, the drive will start as normally programmed.

Two (2) = ramp-to-stop. Upon receiving a Stop command, the drive will begin to ramp the output frequency down to zero. The decel ramp followed will be either Decel Time 1 or Decel Time 2, whichever is selected. After the output frequency is reduced to zero, the drive will apply a DC hold voltage to the motor if Parameters 12 and 13 are set to values other than zero.



**ATTENTION:** The user has the ultimate responsibility to determine which stopping mode is best suited to the application and which stopping mode will meet applicable standards for operator safety on a particular application.

---

**Parameter 11 — Decel Frequency Hold**

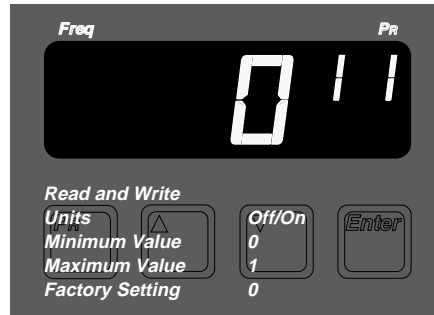

This parameter may be used to guard against overvoltage fault trips from occurring due to fast decel ramps. The status of this parameter selects the drive response to a condition where the DC bus level is rising towards the overvoltage trip point.

With Decel Frequency Hold set to **0**, drive logic continues to follow the decel ramp. If the bus voltage rises to 810V DC however, the drive will trip a bus overvoltage fault (F05).

With Decel Frequency Hold set to **1**, the drive logic will not follow the programmed decel ramp if the bus voltage rises above 110% of nominal bus voltage. Typically a rise in bus voltage is the result of decelerating at a fast rate. This causes the connected motor to regenerate energy back to the DC bus faster than the drive/motor can dissipate the energy. With the decel ramp inhibited, the regenerated energy will reduce and stop increasing the DC bus voltage. As the amount of regenerated energy decreases, the DC bus voltage decreases to below 110% of nominal bus voltage and allows the drive logic to continue its original decel ramp.

## Parameter 12 — DC Hold Time

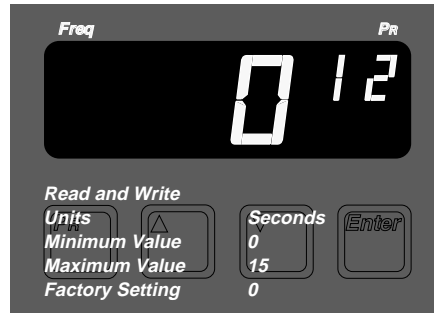

The time represented by this value affects drive stopping performance. Parameter 10 determines how this parameter value is used.

When Parameter 10 is set to **0**, Parameters 12 and 13 should also be set to **0**. When the drive receives a Stop command, DC Hold Time represents how long the last speed command value will be retained in memory. If the drive is restarted within this time frame, the drive resumes its last speed command without accelerating from zero speed. If the elapsed time between a Stop and a Start command is longer than the DC Hold Time, the drive will restart at zero speed and follow the standard start sequence.

When Parameter 10 is set to **1** and the drive receives a Stop command, drive output frequency to the motor stops. A DC Hold Voltage is sent to brake the motor for a time equal to the DC Hold Time. If a Start command is received within the DC Hold Time, the drive will remove DC Hold Voltage from the motor and re-accelerate back to set speed. If a Start command is received after the DC Hold Time, the drive will follow the standard start sequence.

When Parameter 10 is set to **2**, the drive output frequency will ramp-to-stop after which a DC Hold Voltage will be applied to the motor for a time equal to the DC Hold Time. If a Start command is received within the DC Hold Time, the drive will remove the DC Hold Voltage and accelerate from 0 Hz to set speed. If a Start command is received after the DC Hold Time, the drive will follow the standard start sequence.

### Parameter 13 — DC Hold Volts



The value of this parameter sets the DC Hold Voltage that is applied to the motor during the DC Hold Time set by Parameter 12.

The optimum setting for this parameter is a function of external variables — motor size, load inertia, friction load and other factors. It is recommended that this setting be the lowest value needed to achieve the required holding or braking action at zero speed. Voltages above rated motor nameplate value can produce high motor currents during the hold or brake cycle which may lead to motor overheating.



**ATTENTION:** A power interruption lasting longer than 500mS or a malfunction in the solid-state circuitry will cause a loss of holding or braking torque. If a hazard of injury due to movement of equipment or material exists, an auxiliary mechanical braking device must be used.

## Parameter 14 — Auto Restart

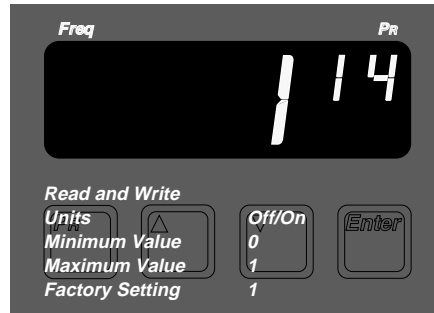

Auto Restart along with Parameters 40 and 85, affects the drive restart sequence after a line loss condition. Parameter 40 allows the sensing of a line power interrupt condition. Parameter 85 sets the number of times the drive will attempt to restart after a fault.

**Important:** Parameters 14 and 85 require two-wire control to allow an auto restart sequence to occur. 1336VT two-wire control requires that Logic Interface Option L1, L2 or L3 be installed in the drive.

When Auto Restart is set to **0**, the Auto Restart function is disabled. With Auto Restart disabled, a stop input must be cycled after F01 is displayed. If a code other than F01 is displayed, a fault has occurred. The fault code must first be cleared by cycling the stop input or power. The stop input must then be recycled after F01 is displayed.

If Auto Restart is set to **1** and Parameter 40 is set to **1**, the Auto Restart function is enabled. Should a line power loss occur, the drive will attempt to restart once power is restored. Should a fault still be present (other than F13-18 and F33), the number of times the drive will attempt to restart is determined by Parameter 85.

When auto restart is set to **1**, recycling a stop input is not required after F01 is displayed. When Auto Restart is enabled however, it inhibits F04, Bus Undervoltage, from occurring.

With a momentary start input supplied from any source, should a drive power loss occur, the drive will restart itself providing the DC bus has not decayed below 200V DC.



**ATTENTION:** Auto Restart operation may only be used as outlined in NFPA79, paragraph 6-14 (Exceptions 1, 2 and 3) for specialized applications. Equipment damage and/or personal injury may result if Parameter 14 settings are used in an inappropriate application.

### Parameter 15 — Factory Set

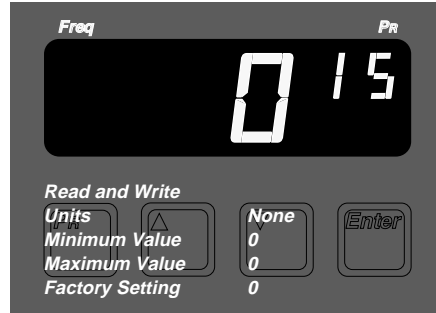

This parameter may be viewed but should not be changed from its factory setting.

### Parameter 16 — Minimum Frequency

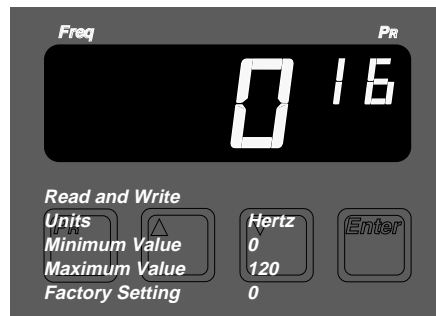

This parameter sets the minimum drive operating frequency. The only running conditions that can override the minimum frequency setting are Jog Frequency (Parameter 24) or Dwell Frequency (Parameter 43). Minimum Frequency also sets the offset or starting point for analog response signals. These include the local and remote potentiometers that may be used to control the drive output frequency. Minimum Frequency is produced at a potentiometer setting of zero. Minimum Frequency will also be produced with a voltage input of zero or a current input of 4mA unless Parameter 84, Analog Inverse is set to **1**.

### Parameter 17 — Base Frequency

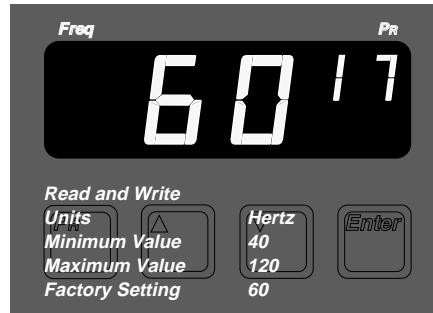

Parameters 17 and 18 are typically set to the nameplate values of the connected motor.

Parameter 17 in conjunction with Parameter 18 and the addition of DC Boost Select set by Parameters 9, 48, 49 and 50, determines the drive output volts-per-hertz slope up to Base Frequency. The value for Base Frequency must be greater than the Minimum Frequency set by Parameter 16 and Break Frequency set by Parameter 49 as shown on page 2-37.

### Parameter 18 — Base Volts

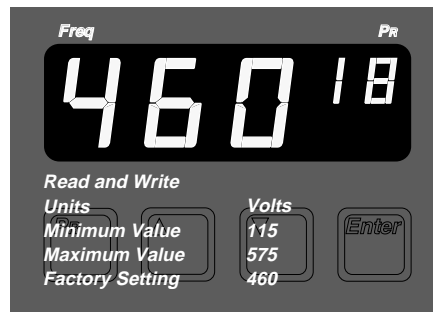

Parameters 17 and 18 are typically set to the nameplate values of the connected motor.

Parameter 18 in conjunction with Parameter 17 determines the drive output volts-per-hertz slope up to Base Frequency unless modified by Parameters 9, 20, 48, 49 and 50. Parameters 9, 48, 49 and 50 may modify the drive slope at startup, while Parameter 20 will limit the maximum drive voltage produced as shown on page 2-37.

**Parameter 19 — Maximum Frequency**

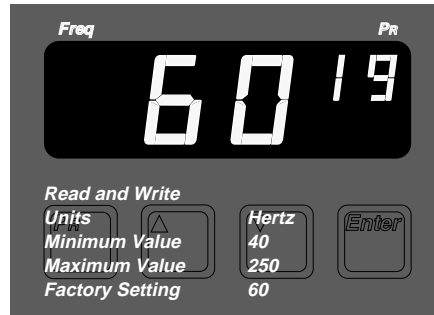

This parameter sets the highest frequency that the drive will produce when given a maximum speed command. The drive reaches this speed when a local or remote potentiometer or a digital speed command is at its maximum level unless Parameter 84 is set to **1**. That is:

- A +10V DC input at its maximum level.
- A 20mA input at its maximum level.
- A digital speed command at its maximum level.

— or if Parameter 84 (Analog Inverse) is enabled —

- A 0V DC input at its maximum level.
- A 4mA input at its maximum level.

Parameter 17 in conjunction with Parameter 18 and the addition of DC Boost Select set by Parameters 9, 48, 49, 50 and 83, determines the drive output volts-per-hertz slope up to Base Frequency. The value for Base Frequency must be greater than the Minimum Frequency set by Parameter 16 and Break Frequency set by Parameter 49 as shown on page 2-37.

If Parameter 19 is set to a value less than Parameter 17 (Base Frequency), drive output frequency will be limited to the value of Parameter 19 as shown on page 2-37.



**ATTENTION:** The drive must be stopped before changing Parameter 19. Decreasing Parameter 19 while the drive is running will produce a sudden change in drive output frequency. Sudden changes in drive output frequency may cause motor torque pulsations that can damage connected equipment.

### Parameter 20 — Maximum Volts

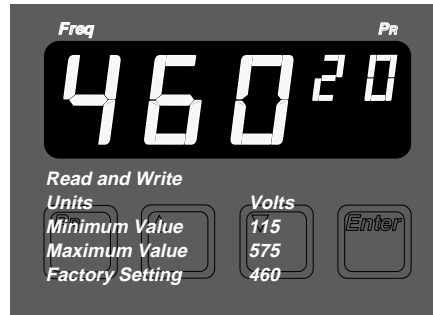

This parameter sets the maximum RMS output voltage of the drive. It may also be used to set the volts-per-hertz curve when the drive is operating between Base Frequency and Maximum Frequency. Beginning at Base Frequency (Parameter 17), drive output voltage will be directly proportional to drive output frequency along a line that starts at Base Voltage (set by Parameter 18), and extends to Maximum Frequency (set by Parameter 19).

This parameter permits the drive to be programmed for custom motor applications. In custom motor applications, the voltage above base speed may need to be controlled differently than below base speed. To be of practical use, the voltage at Base Frequency must be less than the drive Maximum Voltage. If Parameter 20 is set to a value less than Parameter 18 (Base Volts), drive output voltage will be limited to the value of Parameter 20 as shown on page 3-35. For additional information about custom motor applications, contact your A-B sales representative.

### Parameter 21 — Local Run

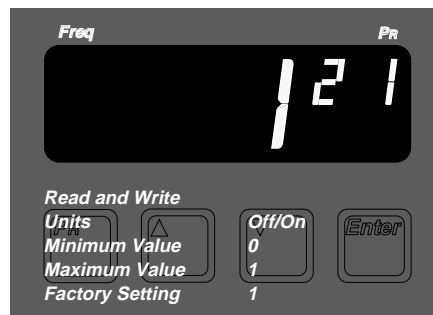

Parameter 21 allows the start pushbutton on an optional local or remote Control Panel to be enabled or disabled. This parameter does not affect any of the other Control Panel functions. All local and remote stop inputs remain active when this parameter is set to **0** or off.

When set to **0**, the drive will not accept a start command from the start pushbutton on the Control Panel. A start command from another source must be used.

When set to **1**, the drive will accept a start command from the Control Panel in addition to start commands from other sources. Enabling the Control Panel start pushbutton does not lock out start commands from other sources.

## Parameter 22 — Local Reverse



Parameter 22 selects the source that determines the direction of motor rotation.



When set to **0**, the direction of rotation is controlled by either the status of the reverse input at TB3 or through serial communications. The direction pushbutton on an optional Control Panel is not functional, but the direction LED display on the Control Panel is functional.



When set to **1**, the direction of rotation is controlled by the Control Panel direction pushbutton. Other sources of reversing control are disabled, and the direction of rotation cannot be changed by inputs from TB3 or through serial communications.

## Parameter 23 — Local Jog



Parameter 23 determines if an optional Control Panel jog pushbutton can jog the drive. The setting of this parameter will not disable jog commands from other sources and will not disable other functions on the Control Panel.

When set to **0**, the Control Panel jog function is disabled. The jog pushbutton on an optional Control Panel will have no affect, but the jog input at TB3 or serial communication command can jog the drive.

When set to **1**, the Control Panel jog function is enabled. The jog pushbutton on the Control Panel will jog the drive as long as it is pressed. Other sources of control will still be functional and jog inputs from TB3 or serial communications can jog the drive.

### Parameter 24 — Jog Frequency

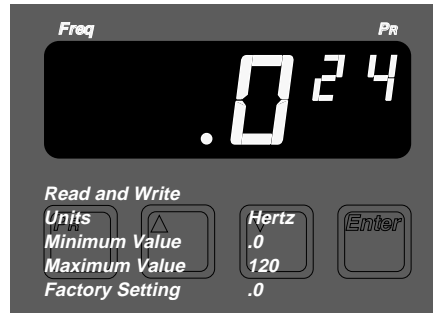

The value of this parameter is the speed reference frequency used when jog is commanded. Any time jog is commanded, the drive will ramp to this frequency. Upon removing the jog command, if no other motion command is present, the drive will follow the stopping mode selected in Parameter 10. This parameter may be lower than the Minimum Frequency set by Parameter 16, but will be limited by the Maximum Frequency set by Parameter 19.

### Parameter 25 — Analog Output

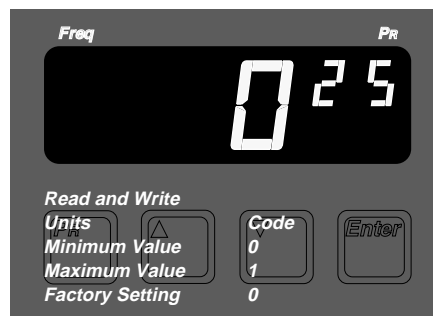

This parameter selects which one of the two possible output signals are used as the meter output at TB2, Terminal 9.

When set to **0**, the meter output is proportional to the actual output frequency of the drive.

When set to **1**, the meter output is proportional to the % of drive load current.

**Important:** The displayed load current is an approximate value calculated from drive internal feedback. Motor characteristics will affect the accuracy of the load current indication.

**Parameter 26 — Preset/2<sup>nd</sup> Accel**

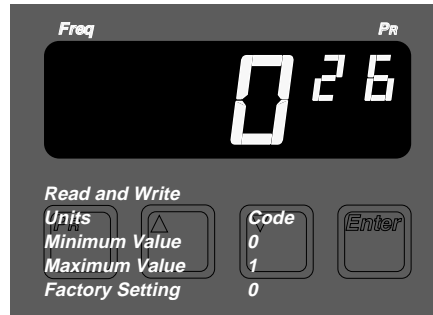

This parameter selects which drive function will be controlled by optional inputs SW1, SW2, Speed Select at terminal block TB3 and Parameter 72, Activate Parameters 73-76.

**Important:** The settings of Serial Input (Parameter 56) and Serial Mask (Parameter 57) will affect the selection of Preset Frequencies 1, 2, 3, 4, 5, 6 and 7. Bits 2 and 3 of Parameter 56 select the source for drive preset speed control. Bits 0 and 1 of Parameter 56 select the source for drive accel and decel control.

If Parameter 26 is set to **0**, accel and decel times will be set by Accel Time 1 (Parameter 7) and Decel Time 1 (Parameter 8). SW1, SW2, Speed Select and Parameter 72 will control the selection of Preset Frequencies as follows:

SW1	SW2	Speed Select	Parameter 72	Accel at Accel Time 1, Parameter 7 Decel at Decel Time 1, Parameter 8 Run at:
False	False	False	Off	Frequency Select 1, Parameter 5
True	False	False	Off	Preset Frequency 1, Parameter 27
False	True	False	Off	Preset Frequency 2, Parameter 28
True	True	False	Off	Preset Frequency 3, Parameter 29
False	False	True	Off	Frequency Select 2, Parameter 6
True	False	True	Off	Preset Frequency 1, Parameter 27
False	True	True	Off	Preset Frequency 2, Parameter 28
True	True	True	Off	Preset Frequency 3, Parameter 29
False	False	False	On	Frequency Select 1, Parameter 5
True	False	False	On	Preset Frequency 1, Parameter 27
False	True	False	On	Preset Frequency 2, Parameter 28
True	True	False	On	Preset Frequency 3, Parameter 29
False	False	True	On	Preset Frequency 4, Parameter 73
True	False	True	On	Preset Frequency 5, Parameter 74
False	True	True	On	Preset Frequency 6, Parameter 75
True	True	True	On	Preset Frequency 7, Parameter 76

**Important:** The settings of Serial Input (Parameter 56) and Serial Mask (Parameter 57) will affect the selection of Accel Times 1 and 2. Bits 0 and 1 of Parameter 56 select the source for drive accel and decel control. Bits 2 and 3 of Parameter 56 select the source for drive preset speed control.

**Parameter 26 — Preset/2<sup>nd</sup> Accel  
 (cont.)**

If Parameter 26 is set to **1**, SW1, SW2, Speed Select and Parameter 72 will control the selection of Run, Accel and Decel as follows:

SW1	SW2	Speed Select	Parameter 72	Run at Frequency Select 1, Parameter 5 Accel at: Decel at:
False	False	False	Off	Accel Time 1, Parameter 7 Decel Time 1, Parameter 8
True	False	False	Off	Accel Time 2, Parameter 30 Decel Time 1, Parameter 8
False	True	False	Off	Accel Time 1, Parameter 7 Decel Time 2, Parameter 31
True	True	False	Off	Accel Time 2, Parameter 30 Decel Time 2, Parameter 31
SW1	SW2	Speed Select	Parameter 72	Run at Frequency Select 2, Parameter 6 Accel at: Decel at:
False	False	True	Off	Accel Time 1, Parameter 7 Decel Time 1, Parameter 8
True	False	True	Off	Accel Time 2, Parameter 30 Decel Time 1, Parameter 8
False	True	True	Off	Accel Time 1, Parameter 7 Decel Time 2, Parameter 31
True	True	True	Off	Accel Time 2, Parameter 30 Decel Time 2, Parameter 31
SW1	SW2	Speed Select	Parameter 72	Run at Frequency Select 1, Parameter 5 Accel at: Decel at:
False	False	False	On	Accel Time 1, Parameter 7 Decel Time 1, Parameter 8
True	False	False	On	Accel Time 2, Parameter 30 Decel Time 1, Parameter 8
False	True	False	On	Accel Time 1, Parameter 7 Decel Time 2, Parameter 31
True	True	False	On	Accel Time 2, Parameter 30 Decel Time 2, Parameter 31
SW1	SW2	Speed Select	Parameter 72	Run at Preset Frequency 4, Parameter 73 Accel at: Decel at:
False	False	True	On	Accel Time 1, Parameter 7 Decel Time 1, Parameter 8
True	False	True	On	Accel Time 2, Parameter 30 Decel Time 1, Parameter 8
False	True	True	On	Accel Time 1, Parameter 7 Decel Time 2, Parameter 31
True	True	True	On	Accel Time 2, Parameter 30 Decel Time 2, Parameter 31

**Parameter 27 — Preset  
Frequency 1**

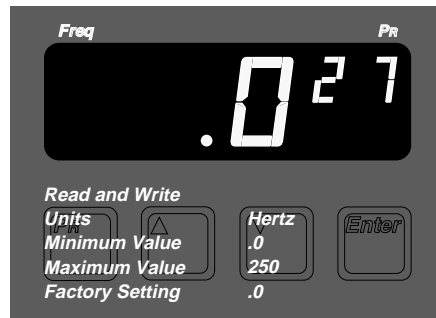

The value of this parameter is the command frequency when Preset Frequency 1 is selected.

**Parameter 28 — Preset  
Frequency 2**



The value of this parameter is the command frequency when Preset Frequency 2 is selected.

**Parameter 29 — Preset  
Frequency 3**

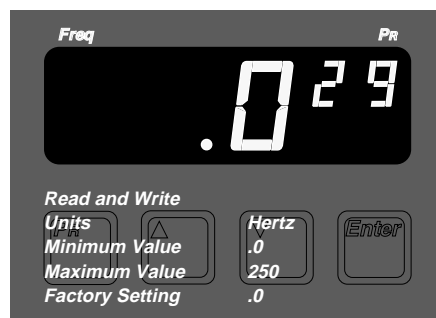

The value of this parameter is the command frequency when Preset Frequency 3 is selected.

### Parameter 30 — Accel Time 2



The value of this parameter is the time in seconds it will take the drive frequency to ramp from zero to the Maximum Frequency set by Parameter 19 when Accel Time 2 is selected.

### Parameter 31 — Decel Time 2

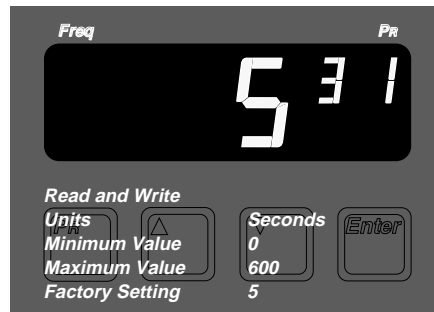

The value of this parameter is the time in seconds it will take the drive to ramp from the Maximum Frequency set by Parameter 19 to zero when Decel Time 2 is selected.

**Parameters 32-35**

Parameters 32 – 35 may be used to program up to three Skip Frequency Bands. Each band establishes a range of frequencies at which the drive will not operate. If the frequency source that is presently controlling the drive is within the band, the drive output frequency will stay slightly above or below the band until the frequency source changes to a frequency outside the band. The drive will then ramp up or down through the band to the desired frequency. Parameters 32, 33 and 34 are programmed for the center frequency of the bands.

**Parameter 32 — Skip Frequency 1**



**Parameter 33 — Skip Frequency 2**

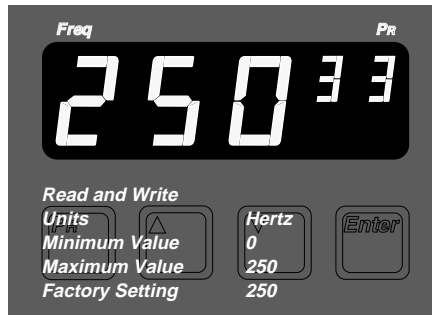

**Parameter 34 — Skip Frequency 3**

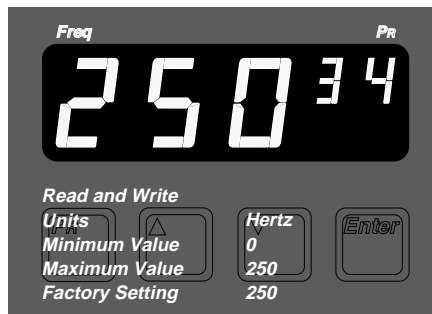

### Parameter 35 — Skip Frequency Band

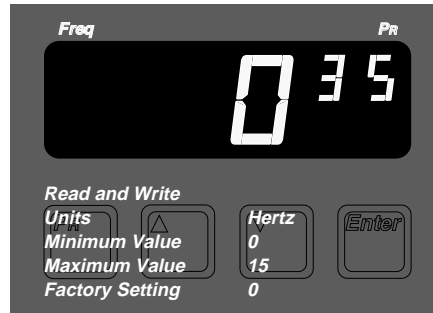

Parameter 35 is programmed for the Skip Frequency Band — the range of frequencies to skip. It is used for each of the skip frequency ranges programmed. The actual range will be the skip frequency (Parameter 32, 33 or 34) minus the value of Parameter 35, to the skip frequency plus the value of Parameter 35.

Example: If Parameter 32 = 30 Hz and Parameter 35 = 5 Hz, a skip frequency band from 25 Hz ( $30 - 5$ ) to 35 Hz ( $30 + 5$ ) will be generated.

If two or more of the skip frequencies are programmed with values that along with the Skip Frequency Band produce overlapping ranges, it will result in one large range.

Example: Parameter 32 = 20 Hz  
Parameter 33 = 30 Hz  
Parameter 34 = 50 Hz  
Parameter 35 = 6 Hz

These values establish two skip frequency ranges. One range is from 14 Hz ( $20 - 6$ ) to 36 Hz ( $30 + 6$ ). The other range is from 44 Hz ( $50 - 6$ ) to 56 Hz ( $50 + 6$ ). Since the upper limit of the first range ( $20 + 6 = 26$ ), is higher than the frequency at the lower limit of the second range ( $30 - 6 = 24$ ), they combine to form one large range.

## Parameter 36 — MOPC

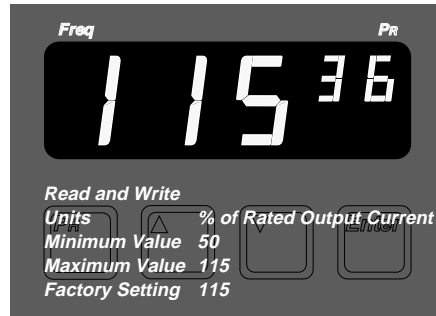

**Important:** Overload Current (Parameter 38) limits the drive output current independent of the setting of Parameter 36. The overload range available from the drive will be limited by the lower of the two settings. If the setting of Parameter 36 is greater than the setting of Parameter 38, an overload condition could occur before MOPC is activated.

The value of this parameter adjusts the Momentary Overload Protection Circuit setting of the drive in units of % of rated output current. When the drive output current attempts to exceed this value, the drive will respond by reducing frequency and voltage to limit drive output current to this value. Once output current is reduced below this value, the drive will ramp back to command frequency.

### Parameter 37 — Serial Baud Rate

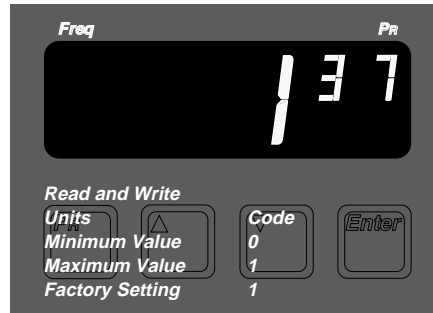

This parameter allows the baud rate for communicating with remote serial devices to be set to either 9600 (0) or 2400 (1) baud. Each time Parameter 37 is changed, power must be recycled to the drive before the new baud rate can be used.

The 9600 baud rate permits faster communications with remote serial devices and reduces update time. The 2400 baud rate provides slower communications, but improves communication accuracy with remote serial devices. If communication errors occur or erratic data is displayed, the slower baud rate should be used.

Serial devices are connected to the 1336-MOD-S1 Serial Port. The baud rate of the 1336-MOD-G2 Remote I/O Adapter must be set to match this parameter setting. The 1336-MOD-E1 Handheld Terminal and 1336-MOD-E2 Monitor Display, upon power up, automatically detect the setting of the drive baud rate and do not need to be reset to match Parameter 37.

## Parameter 38 — Overload Current

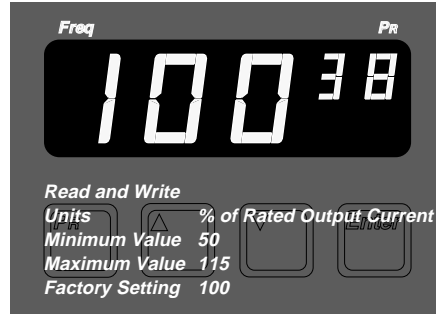

**Important:** MOPC Parameter 36 limits the drive output current independent of the setting of Parameter 38. The overload range available from the drive will be limited by the lower of the two settings. If the setting of Parameter 36 is greater than the setting of Parameter 38, an overload condition could occur before MOPC is activated.

When used with the branch circuit protection fuses recommended in the 1336VT User Manual, this parameter provides inverse timed overload protection designed to meet NEC and UL equivalent requirements. Parameter Settings for all ratings are listed in Chapter 6 — Overload Current Settings.

To approximate the  $I^2T$  motor thermal overload cutoff, timing starts when the output current rises above this parameter setting. Output current is then timed inversely proportional to the level of current above this setting. When the timed trip level is reached, the drive will fault, display Fault Code F07 and coast-to-stop.

### Parameter 38 Selection

The value of Parameter 38 is selected from the charts in Chapter 6 based on drive rating and approximate motor full load current rating. Enter the value found in the column labeled % corresponding to the correct data.

**Important:** The overload current setting is intended for use with single motor applications. When two or more motors are connected to the drive output, individual motor thermal overloads are recommended and Parameter 38 must be set to 100. The drive cannot detect or be programmed to monitor individual motor currents.

### Parameter 39 — Fault Clear

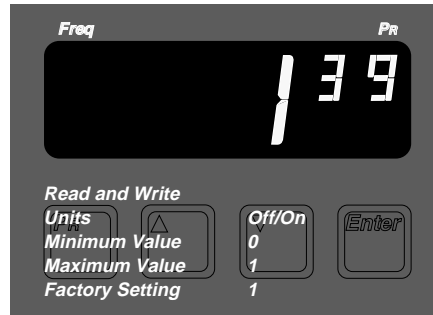

This parameter determines the sequence of events required to clear a Fault Code at the drive. The setting of Parameter 14, Auto Restart, will affect the sequence required to reset the drive after a fault has occurred. The setting of Parameter 40, Power Fault, will affect the sequence required to reset the drive after an AC 3-phase line power interruption has occurred.

If set to **0**, a Fault Code can only be cleared by removing input power from the drive, letting the bus discharge, then reapplying input power.

If set to **1**, a Fault Code can be cleared by either removing input power from the drive, letting the bus discharge then reapplying input power, or by causing the stop signal from an optional Control Panel or Terminal 20 of TB3 on the Logic Interface Board (MOD-L1, L2 or L3) to go false then true with a maintained false Start command.

If MOD-G2 Serial Communications, is being used, toggling the discrete stop bit will not perform this function, refer to Parameter 51.

## Parameter 40 — Power Fault

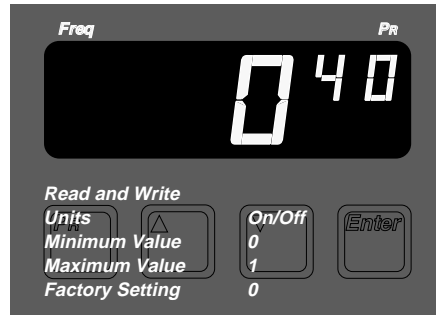

This parameter allows the sensing of a line power interrupt condition.

If set to **1**, only the following sequence can occur.

On interruption of input power to the drive, the drive will continue to operate from the stored energy of the DC bus until bus voltage drops below 85% of its nominal value. At this point, drive output is shut off and the DC bus will discharge slower. Operating logic status will be retained as long as bus voltage is above 388V DC.

If input power is restored and bus voltage rises above 85% of its nominal value, the drive will restore output power to the motor and continue to run. Should DC bus voltage fall below 388V DC however, a Bus Undervoltage Fault (F04) will be displayed.

If set to **0**, and additional Fault, Input Power Loss F03 may be displayed.

In addition to the above sequence, when the DC bus drops below 85% of its nominal value but remains above 388V DC, a 500 msec timer is started. If bus voltage does not rise above 85% of its nominal value before 500 msec, the drive will trip, shut down and display Fault F03. If input power is restored and bus voltage rises above 85% of its nominal level before 500 msec, the drive will resume operation and the timer will be reset.

## Parameter 41 — Motor Type

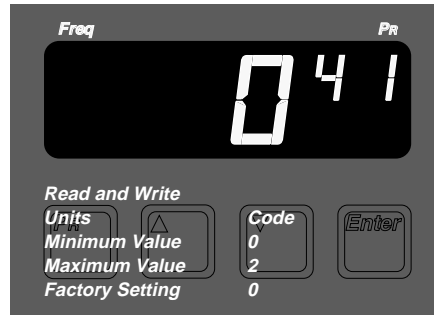

Parameter 41 allows one of three motor types to be selected for drive control:

- Induction by setting Parameter 41 to **0**.
- Synchronous reluctance by setting Parameter 41 to **1**.
- Synchronous Permanent Magnet by setting Parameter 41 to **2**.

The value of Parameter 41 directly effects the programming of drive Parameters 10 and 42.

When Parameter 41 is set to **2** (Synchronous Permanent Magnet Motor), Parameter 10 must not be set to 1 (DC Brake-to-Stop). This type of braking will reduce the field strength of the permanent magnets in the motor.

When Parameter 41 is set to a value of either **1** (Synchronous Reluctance), or **2** (Synchronous Permanent Magnet), Parameter 42 must be set to **0** (no slip compensation). Synchronous motors run without slip, and slip compensation will not allow the motor to run at synchronous speed.

If the value of Parameters 10, 41 and 42 are not compatible, the drive will detect it and Fault Code F11 (Operator Error), will appear when an attempt is made to start the drive.

The type of motor selected restricts other parameters. The following parameter settings must be used when selecting Parameter 41 Motor Type.

- Induction Motor — Parameter 41 = **0**
- Synchronous Reluctance Motor — Parameter 41 = **1**  
Parameter 42 = **0**
- Synchronous Permanent Magnet Motor — Parameter 41 = **2**  
Parameter 42 = **0**  
Parameter 10 = **0** or **2**

## Parameter 42 — Slip Compensation

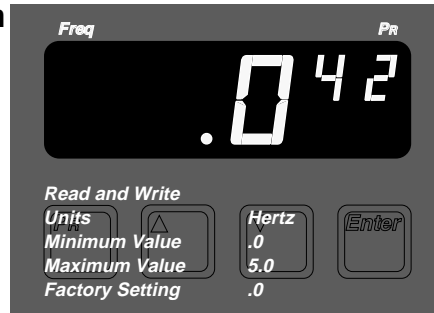

**Important:** Parameter 78, Traverse Period, must be set to **0** to allow Slip Compensation. If not, the drive will fault and display F37 — P-Jump Error.

Parameter 42 adds frequency to the drive output. This added frequency will be seen at the drive Output Frequency Display and will be shown even when the drive is set to zero speed. At Maximum Frequency however, Slip Comp will be clamped by the Maximum Frequency set by Parameter 19.

Slip Compensation is based on a percentage of drive output current and compensates for motor slip in an induction motor. Adding frequency to the drive output shifts the motor speed towards the synchronous speed of the motor. By setting Parameter 42, variations in motor speed due to changes in motor load can be reduced.

The amount of motor load and motor slip is sensed in the drive by monitoring drive output current. Slip compensation may be set from **0** to **5** Hertz. As the output current of the drive increases from zero to full load, the drive adds a portion of the slip compensation setting to the output frequency. If Parameter 66 (Output Frequency) is viewed, it will show the adjusted frequency — Parameter 65 (Command Frequency), plus a portion of Parameter 42 (Slip Compensation Frequency).

For example:

- At 25% of drive full load output current, one-quarter of the hertz set in Parameter 42 will be added to the output frequency of the drive.
- At 50% of drive full load output current, one-half of the hertz set in Parameter 42 will be added to the output frequency of the drive.
- At 75% of drive full load output current, three-quarters of the hertz set in Parameter 42 will be added to the output frequency of the drive.
- At 100% of drive output current, all of the hertz set in Parameter 42 will be added to the output frequency of the drive.

### Parameter 42 — Slip Compensation (cont.)

An “at speed” circuit in the drive monitors drive output frequency. As long as the input speed reference to the drive remains constant, the hertz set by Parameter 42 will be proportionally added to the drive output frequency. If the speed command to the drive is increased or decreased, slip compensation will not be added until the command speed matches the drive output frequency.

For a given command speed, Parameter 42, should be set to produce the minimum amount of variation in motor speed as the motor load varies.

If the motor speed decreases as motor load increases, the value of Parameter 42 should be increased. If the motor speed increases as motor load increases, the value of Parameter 42 should be decreased. If slip compensation for fully loaded motors is desired, an initial setting of **1.7** for Parameter 42 is recommended.

**Important:** Slip compensation cannot increase the drive output frequency above the Maximum Frequency set by Parameter 19. If Maximum Frequency was selected as the optimum full speed before Slip Compensation, Parameter 19 must be set higher to allow Slip Compensation to work at that frequency.

For example:

A typical operating range may be 0 to 60 Hz with Maximum Frequency, Parameter 19, set to **60** and Slip Compensation, Parameter 42, set to **1.7**. These settings will not allow the drive to add slip compensation at a commanded frequency of 60 Hz. The Maximum Frequency, Parameter 19, would have to be reset to **62** Hz to allow slip compensation to be effective at a commanded speed of 60 Hz.

### Parameter 43 — Dwell Frequency

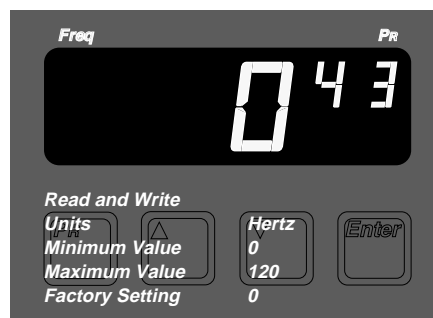

This parameter is not typically used in variable torque applications and should not be changed from its factory setting.

### Parameter 44 — Dwell Time

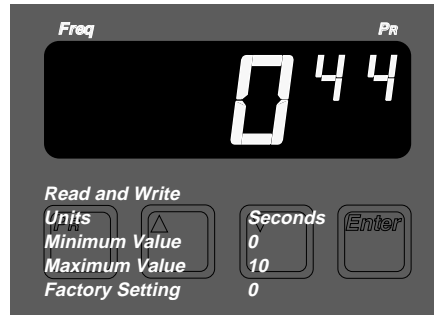

This function sets the time in seconds the drive will hold at the dwell frequency, Parameter 43.

### Parameter 45 — PWM Frequency



This parameter adjusts the minimum carrier frequency used to generate the PWM output waveform. In the range from 0 to 95 Hz, the carrier frequency will be 21 times the generated output frequency, but no less than this value. As an example, the factory setting of **0.4** is a 400 Hz carrier. This carrier will be used from 0 to approximately 19 Hz of drive output. Above 19 Hz, the carrier will change proportionally to the drive output frequency.

Increasing the PWM frequency usually reduces audible motor noise at low speeds, but may result in instability on lightly loaded motors. Reducing the PWM frequency improves motor stability, but may result in increased audible noise.

If the PWM frequency is changed while the drive is running, the drive will perform the PWM frequency change only when the output frequency is changed and not before.

### Parameter 46 — Pulse Scale Factor



This parameter establishes the input pulse ratio required to produce a proportional output command frequency when the pulse train input is selected. The command frequency is determined by dividing the pulse train frequency by the value set by Parameter 46. For example, at **64**, a pulse train input of 3,840 Hz produces a drive command frequency of  $3,840 \div 64$  or 60 Hz.

Maximum pulse input frequency =  $250(\text{Hz}) \times 255(\text{Scale}) = 63750$  pulses per second.

**Important:** The following use the drive pulse train input to control the drive output frequency and require that Parameter 46 be set to **64**:

- 1336-MOD-G1 — The BCD Interface Board
- 1336-MOD-N1 — The Isolated Signal Conditioner Board

### Parameter 47 -- Language

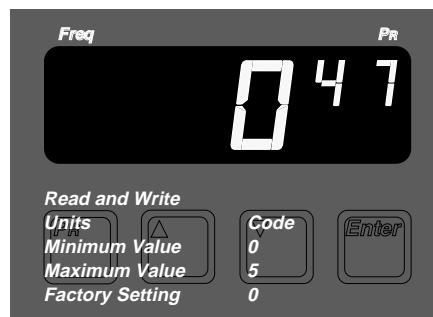

1336-MOD-E1, the Handheld Terminal, has the ability to display text in one of six languages. The setting of this parameter determines which language will be displayed.

- **0** = English
- **1** = French
- **2** = Spanish
- **3** = Italian
- **4** = German
- **5** = Japanese

## Parameters 48-50

**Important:** Parameters 48-50 may be used to program a custom volts-per-hertz curve for the 1336VT for special motor applications.

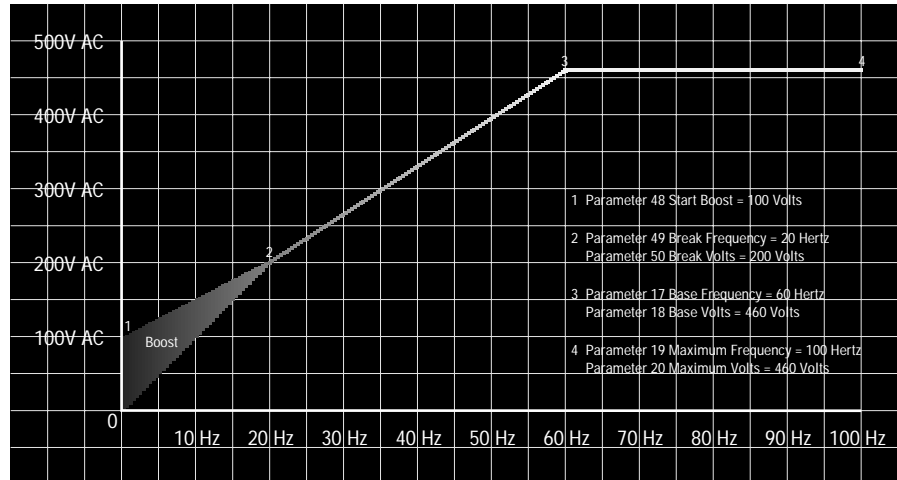

**Parameter 9 = 11 -- Custom Volts-per-Hertz**

## Parameter 48 -- Start Boost

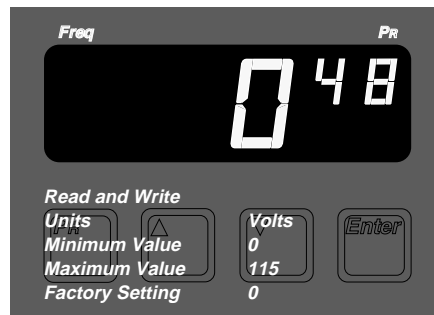

**Important:** If Run Boost (Parameter 83) is greater than Start Boost, the drive will fault and display F34 — Boost Error.

The parameter sets the drive boost voltage if Parameter 9 is set to **11**. This parameter along with Parameters 49 and 50 are used to construct a custom volts-per-hertz curve. If Parameter 83 (Run Boost) is required, this parameter must be set to a value greater than Run Boost and Parameter 9 must be set to **12**.

### Parameter 49 — Break Frequency

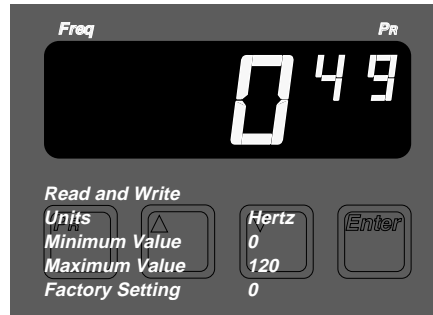

This parameter sets an intermediate frequency below Parameter 17 (Base Frequency), if Parameter 9 is set to **11**. This parameter along with Parameters 48 and 50 are used to construct a custom volts-per-hertz curve.

### Parameter 50 -- Break Volts

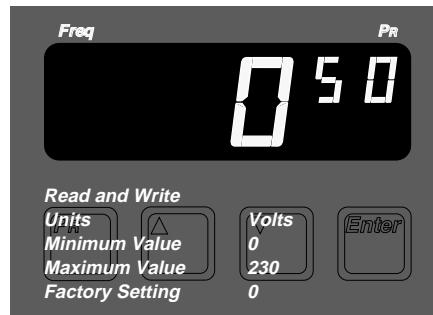

**Important:** If Parameter 50 is less than Parameter 48, the drive will fault and display F35 — Negative Slope.

This parameter sets an intermediate voltage below Parameter 18 (Base Volts), if Parameter 9 is set to **11**. This parameter along with Parameters 48 and 49 are used to construct a custom volts-per-hertz curve. This parameter setting should not be less than Parameter 48.

## Serial Port Parameters

### Firmware Version 1.01-3.01

Parameters 51-69 may only be accessed through options connected to the serial port connector, not through a Programming and Display Panel. For a description of serial port options that use the serial interface, reference the individual option instructions — 1336-MOD-E1, 1336-MOD-E2 and 1336-MOD-G2.

Initial values for each parameter have been preset at the factory and are listed in the following descriptions. Any interaction or preconditions required for setting parameters are also included in the following descriptions.

#### Parameter 51 — Clear Fault

<i>Read and Write</i>	
<i>Read Only</i>	<i>Code</i>
<i>Min Value</i>	0
<i>Max Value</i>	255
<i>Factory Setting</i>	0

This parameter allows the drive to clear a Fault through the serial interface. A BTW set value of from 0-255 will clear the Fault and reset the drive.

#### Parameter 52 -- Input Fault

<i>Read Only</i>	
<i>Units</i>	<i>Code</i>
<i>Min Value</i>	0
<i>Max Value</i>	99

This parameter stores the drive Fault Status for all drive faults. A listing of fault codes and definitions is provided in the 1336VT Hardware User Manual. The parameter value will indicate the number of the fault that is present or 0 if a fault is not present or has been cleared. This is the same value which is displayed at a Programming and Display Panel.

#### Parameter 53 — Drive Fault









<i>Read Only</i>	
<i>Units</i>	<i>Code</i>
<i>Min Value</i>	0
<i>Max Value</i>	99

This is an internal drive parameter used to report a Base Driver/Power Supply Board Fault Parameter 52. Only Base Driver/Power Supply Board fault codes are reported to Parameter 52 by Parameter 53. Non-Base Driver/Power Supply Board fault codes 1, 2, 8, 9, 10, 11, 29, 30, 31 and 33 are not be reported by Parameter 53.

### Parameter 54 — Local Input

<i>Read Only</i>	
<i>Units</i>	<i>Byte</i>
<i>Min Value</i>	0
<i>Max Value</i>	255

This parameter is an eight-bit word that reports the status of the pushbuttons on an optional Control or Programming and Display Panel.

<i>BIT 0</i>	
<i>BIT 1</i>	
<i>BIT 2</i>	
<i>BIT 3</i>	
<i>BIT 4</i>	
<i>BIT 5</i>	
<i>BIT 6</i>	
<i>BIT 7</i>	

0 = Off (not pressed)      1 = On (pressed)

### Parameter 55 — Remote Input

<i>Read Only</i>	
<i>Units</i>	<i>Byte</i>
<i>Min Value</i>	0
<i>Max Value</i>	255

This parameter is an eight-bit word. Each bit represents the status of the customer connection to remote terminal block TB3.

- BIT 0 — TERM 27 — Select speed
  - BIT 1 — TERM 28 — Auxiliary
  - BIT 2 — TERM 26 — SW2
  - BIT 3 — TERM 24 — SW1
  - BIT 4 — TERM 22 — Jog
  - BIT 5 — TERM 23 — Reverse
  - BIT 6 — TERM 20 — (not) Stop
  - BIT 7 — TERM 19 — Start
- 0 = Off (not present)      1 = On (present)

## Parameter 56 — Serial Input

<i>Read Only</i>	
<i>Units</i>	<i>Byte</i>
<i>Min Value</i>	0
<i>Max Value</i>	255

This parameter is the drive storage location for the Serial Input byte. This same byte is used to control the drive through the PLC Controller Output Image Table. This parameter is an eight-bit word where each bit represents the following parameter or control function.

The Serial Mask Parameter 57, controls whether these bits are used by the drive. The Serial Mask must first be set through PLC programmable controller block transfer before this byte will be accepted by the drive.

BIT 0 — Decel Time — **0** = select Decel Time 1, Parameter 8  
**1** = select Decel Time 2, Parameter 31

BIT 1 — Accel Time — **0** = select Accel Time 1, Parameter 7  
**1** = select Accel Time 2, Parameter 30

### **BITS 2 and 3 — Frequency Control**

If either Speed Select is false or Parameter 72 is set to **0** (Off), the combination of bits 2 and 3 selects Preset Frequency 1, 2 or 3, or Frequency Select 1 or 2 as follows:

BIT 2 = 0 and BIT 3 = **0** — select Frequency Select 1 or 2, Parameters 5 or 6

BIT 2 = 0 and BIT 3 = **1** — select Preset Frequency 1, Parameter 27

BIT 2 = 1 and BIT 3 = **0** — select Preset Frequency 2, Parameter 28

BIT 2 = 1 and BIT 3 = **1** — select Preset Frequency 3, Parameter 29

When both Speed Select is true and Parameter 72 is set to **1** (On), the combination of bits 2 and 3 selects Preset Frequency 4, 5, 6 or 7 as follows:

BIT 2 = 0 and BIT 3 = **0** — select Preset Frequency 4, Parameter 73

BIT 2 = 1 and BIT 3 = **0** — select Preset Frequency 5, Parameter 74

BIT 2 = 0 and BIT 3 = **1** — select Preset Frequency 6, Parameter 75

BIT 2 = 1 and BIT 3 = **1** — select Preset Frequency 7, Parameter 76

**Parameter 56 — Serial Input  
(cont.)**

BIT 4 — Jog	— <b>0</b> = select (not) Jog — continue last state <b>1</b> = select Jog at Jog Frequency, Parameter 24
BIT 5 — Direction	— <b>0</b> = select Forward <b>1</b> = select Reverse
BIT 6 — Stop	— <b>0</b> = select Stop <b>1</b> = select (not) Stop — continue last state
BIT 7 — Start	— <b>0</b> = select (not) Start — continue last state <b>1</b> = select Start



**ATTENTION:** Unexpected machine motion can cause injury or death. Do not use a Local or Remote Control Panel with option G2 or in any maintained serial control start application.

A maintained start input from the Serial Input Byte (Par 56, BIT 7) will affect Control Panel stop pushbutton operation. The drive will automatically restart after the Control Panel stop pushbutton is depressed and released.

---

## Parameter 57 — Serial Mask

<i>Read and Write</i>	
<i>Units</i>	<i>Byte</i>
<i>Min Value</i>	0
<i>Max Value</i>	255
<i>Factory Setting</i>	0

This parameter permits the masking of any one of the bits defined in Parameter 56. Each bit in this parameter must be set to 1 to allow the corresponding bit in Parameter 56 to be fully functional.

**Important:** If power is removed from the drive, a default state will occur resetting all bits in Parameter 57 to **0**.

BIT 0 — Decel Time — **0** = use SW2 at terminal block TB3 to select Decel Time 1 or 2. Bit 0 of Parameter 56 ignored.

**1** = use bit 0 of Parameter 56 to select Decel Time 1 or 2. SW2 at terminal block TB3 ignored.

BIT 1 — Accel Time — **0** = use SW1 at terminal block TB3 to select Accel Time 1 or 2. Bit 1 of Parameter 56 ignored.

**1** = use bit 1 of Parameter 56 to select Accel Time 1 or 2. SW2 at terminal block TB3 ignored.

BIT 2 — Frequency Control — **0** = use SW2 at terminal block TB3 to select Preset Frequency 1-7. Bit 2 of Parameter 56 ignored.

**1** = use bit 2 of Parameter 56 to select Preset Frequency 1-7. SW2 at terminal block TB3 ignored.

BIT 3 — Frequency Control — **0** = use SW1 at terminal block TB3 to select Preset Frequency 1-7. Bit 3 of Parameter 56 ignored.

**1** = use bit 3 of Parameter 56 to select Preset Frequency 1-7. SW1 at terminal block TB3 ignored.

**Parameter 57 — Serial Mask  
(cont.)**

BIT 4 — Jog

- **0** = drive will not accept Jog command bit
- **1** = Jog at Jog Frequency, Parameter 24, may be selected.

BIT 5 — Direction

- **0** = drive will not accept Direction command bit.
- **1** = direction change allowed.

BIT 6 — Stop

- **0** = data will not stop drive.
- **1** = data will stop drive.

BIT 7 — Start

- **0** = data will not start drive.
- **1** = data will start drive.

## Parameter 58 — Drive Command

<i>Read Only</i>	
<i>Units</i>	<i>Byte</i>
<i>Min Value</i>	0
<i>Max Value</i>	255

This parameter represents the status of various inputs that control the drive. It is an eight-bit word but only five bits contain actual status information.

- |                     |   |
|---------------------|---|
| BIT 0 — Direction   | — <b>0</b> = forward<br><b>1</b> = reverse  |
| BIT 1 — Enable      | — <b>0</b> = drive (not) enabled<br><b>1</b> = drive enabled                            |
| BIT 2 — Run         | — <b>0</b> = stop (Run command not present)<br><b>1</b> = run (Run command present)     |
| BIT 3 — Accel Time  | — <b>0</b> = use Accel Time 1, Parameter 7<br><b>1</b> = use Accel Time 2, Parameter 30 |
| BIT 4 — Decel Time  | — <b>0</b> = use Decel Time 1, Parameter 8<br><b>1</b> = use Decel Time 2, Parameter 31 |
| BIT 5 — not defined |   |
| BIT 6 — not defined |   |
| BIT 7 — not defined |   |

## Parameter 59 — Drive Status

<i>Read Only</i>	
<i>Units</i>	<i>Byte</i>
<i>Min Value</i>	0
<i>Max Value</i>	255

This parameter is an eight-bit word that corresponds to the status byte read by the PLC Controller input image table. It reports the actual operating status of the drive.

BIT 0 — Direction	— <b>0</b> = forward <b>1</b> = reverse
BIT 1 — Enable	— <b>0</b> = drive (not) enabled <b>1</b> = drive enabled
BIT 2 — Fault	— <b>0</b> = fault not present <b>1</b> = drive faulted
BIT 3 — Alarm	— <b>0</b> = alarm not present <b>1</b> = one of six alarms is present
BIT 4 — Run	— <b>0</b> = drive stopped <b>1</b> = drive running
BIT 5 — Set Speed	— <b>0</b> = drive not at Frequency Command, Parameter 65 <b>1</b> = drive is within Frequency Command limits, Parameter 65
BIT 6 — Accel	— <b>0</b> = drive is not accelerating <b>1</b> = drive is accelerating
BIT 7 — Decel	— <b>0</b> = drive is not decelerating <b>1</b> = drive is decelerating

## Parameter 60 — Drive Alarm

<i>Read Only</i>	
<i>Units</i>	<i>Byte</i>
<i>Min Value</i>	0
<i>Max Value</i>	255

This parameter is an eight-bit word that shows the status of the six possible drive alarm conditions.

- BIT 0 — Drive Output Current — **0** = output current below 115%  
**1** = output current above 115%
- BIT 1 — MOPC Limit — **0** = output current is below MOPC limit set by Parameter 36  
**1** = output current is above MOPC limit set by Parameter 36
- BIT 2 — High Bus Voltage — **0** = bus voltage below 110% of nominal input voltage  
**1** = bus voltage above 110% of nominal input voltage — Frequency Hold is active if Parameter 11 is set to 1
- BIT 3 — Low Bus Voltage — **0** = bus voltage above 85% of nominal input voltage  
**1** = bus voltage below 85% of nominal input voltage
- BIT 4 — not used
- BIT 5 — precharge — **0** = precharge complete  
**1** = precharge not complete
- BIT 6 — Auto Restart Alarm — **0** = Auto Restart function inactive  
**1** = Auto Restart function active (Refer to Parameter 85)
- BIT 7 — not used

## Parameter 61 — Drive Type

*Read Only*  
*Units*                      *Byte*  
*Min Value*                 0  
*Max Value*                 255

This parameter is an eight bit word that indicates the voltage and power rating of the drive.

BIT 7	BIT 6	BIT 5	BIT 4	BIT 3	BIT 2	BIT 1	BIT 0	
1	1	0	0	0	1	1	0	= B003 (380/415/460V AC)
1	1	0	0	0	1	1	1	= B005 (380/415/460V AC)
1	1	0	0	1	0	0	0	= B007 (380/415/460V AC)
1	1	0	0	1	0	0	1	= B010 (380/415/460V AC)
1	1	0	0	1	0	1	0	= B015 (380/415/460V AC)
1	1	0	0	1	0	1	1	= B020 (380/415/460V AC)
1	1	0	0	1	1	0	0	= B025 (380/415/460V AC)
1	1	0	0	1	1	0	1	= B030 (380/415/460V AC)
1	1	0	0	1	1	1	0	= B040 (380/415/460V AC)
1	1	0	0	1	1	1	1	= B050 (380/415/460V AC)
1	1	0	1	0	0	0	0	= B060 (380/415/460V AC)
1	1	0	1	0	0	0	1	= B075 (380/415/460V AC)
1	1	0	1	0	0	1	0	= B100 (380/415/460V AC)
1	1	0	1	0	0	1	1	= B125 (380/415/460V AC)
1	1	0	1	0	1	0	0	= B150 (380/415/460V AC)
1	1	0	1	0	1	0	1	= B200 (380/415/460V AC)
1	1	0	1	0	1	1	0	= B250 (380/415/460V AC)

### Parameter 62 — Frequency Source

<i>Read Only</i>	
<i>Units</i>	<i>Code</i>
<i>Min Value</i>	0
<i>Max Value</i>	13

This parameter reports to the drive which frequency source is currently being used to command the drive.

- 0** — Local speed pot
- 1** — 0 to +10V input
- 2** — 4 – 20mA input
- 3** — Pulse train input
- 4** — Serial input
- 5** — Remote speed pot input
- 6** — Jog selected
- 7** — Preset Speed 1
- 8** — Preset Speed 2
- 9** — Preset Speed 3
- 10** — Preset Speed 4
- 11** — Preset Speed 5
- 12** — Preset Speed 6
- 13** — Preset Speed 7

### Parameter 63 — Pulse Input

<i>Read and Write</i>	
<i>Units</i>	<i>Hertz</i>
<i>Min Value</i>	0.00
<i>Max Value</i>	250.00

This parameter represents the output frequency to be produced by the pulse input at TB2, Terminal 8.

### Parameter 64 — Serial Frequency

<i>Read and Write</i>	
<i>Units</i>	<i>Hertz</i>
<i>Min Value</i>	0.00
<i>Max Value</i>	250.00
<i>Factory Setting</i>	0.00

This parameter sets the output frequency that will be used as the Command Frequency when serial communication is used for speed commands.

**Parameter 65 — Command Frequency**

<i>Read Only</i>	
<i>Units</i>	<i>Hertz</i>
<i>Min Value</i>	<i>0.00</i>
<i>Max Value</i>	<i>250.00</i>

This parameter represents the present drive command frequency set by the current command source. The current command source will be indicated by a code from 0-9 and shown by selecting Parameters 5 or 6.

**Parameter 66 — Output Frequency**

<i>Read Only</i>	
<i>Units</i>	<i>Hertz</i>
<i>Min Value</i>	<i>0.00</i>
<i>Max Value</i>	<i>250.00</i>

This parameter represents and will display the actual output frequency of the drive and will change as programmed parameters interact with the Command Frequency, Parameter 65. It is used in the PLC Controller Discrete Transfer.

**Parameter 67— Output Pulses**

<i>Read Only</i>	
<i>Units</i>	<i>1 Rev/256</i>
<i>Min Value</i>	<i>0</i>
<i>Max Value</i>	<i>65535/256</i>

This parameter represents the angular position of the output waveform to 1 in 256 parts of an output cycle. It will continually increment from 0 to 65535 or 65535 to 0, then repeat as long as the drive is running.

**Parameter 68 — Serial Password**

<i>Read and Write</i>	
<i>Units</i>	<i>Code</i>
<i>Min Value</i>	<i>0</i>
<i>Max Value</i>	<i>9999</i>
<i>Factory Setting</i>	<i>0</i>

This parameter stores the access code used with the remote handheld programming device and is not intended to be used with remote I/O board programming. Once set, you can read the password only through RIO board programming.

**Parameter 69 — Reverse Status**

<i>Read and Write</i>	
<i>Units</i>	<i>Code</i>
<i>Min Value</i>	<i>0</i>
<i>Max Value</i>	<i>1</i>
<i>Factory Setting</i>	<i>0</i>

This parameter serves as a memory location for the direction of drive rotation as controlled by the Local Control Panel.

## Local and Serial Port Parameters Firmware Version 2.01-3.01

The remaining parameters — from 70 on up — are local and serial port parameters that may only be accessed with Firmware Version 2.01-3.01.

Initial values for each parameter have been preset at the factory and are listed in the following descriptions. Any interaction or preconditions required for setting parameters are also included in the following descriptions.

### Parameter 70 -- Base Driver Board Version



This parameter displays Firmware Version 3.01 located on the Base Driver Board in decimal format.

### Parameter 71 -- Control Board Version



This parameter displays Firmware Version 2.01 located on the Main Control Board in decimal format.

**Parameter 72 -- Activate  
Parameters 73-76**

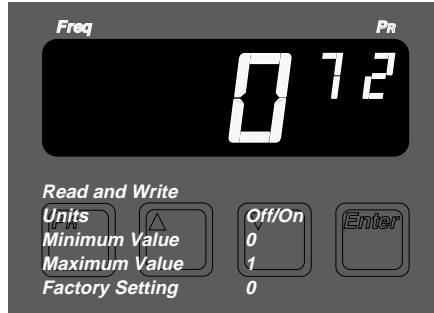

If set to **1**, this parameter will allow Preset Frequencies 73-76 to be used. Individual preset frequencies are selected by the setting of switches SW1 and SW2, and the Speed Select input at terminal block TB3 of the drive. A table listing SW1, SW2, and Speed Select combinations is shown in Chapter 3 — Parameter 26. If the serial input to the drive is used, Parameters 56 (Serial Input) and 57 (Serial Mask) will also determine the selection of Preset Frequencies 73-76.

**Parameter 73 -- Preset  
Frequency 4**

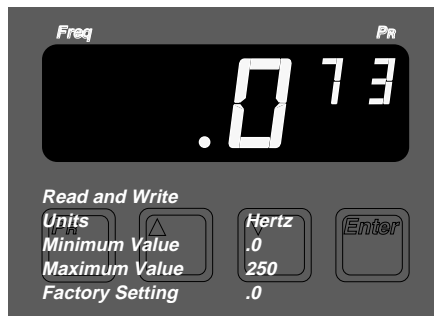

The value of this parameter is the command frequency when Preset Frequency 4 is selected.

**Parameter 74 -- Preset  
Frequency 5**

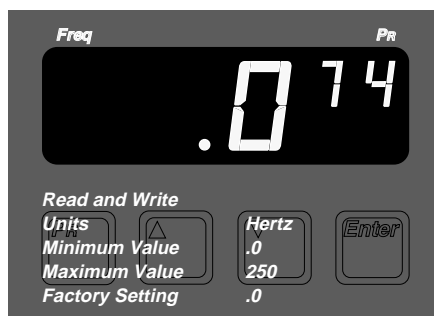

The value of this parameter is the command frequency when Preset Frequency 5 is selected.

**Parameter 75 -- Preset  
Frequency 6**

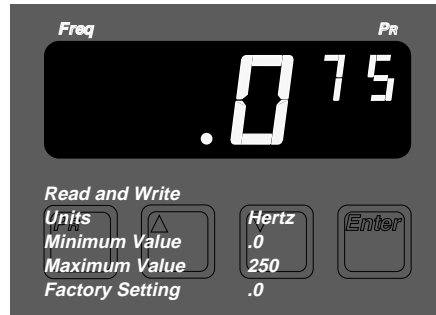

The value of this parameter is the command frequency when Preset Frequency 6 is selected.

**Parameter 76 -- Preset  
Frequency 7**

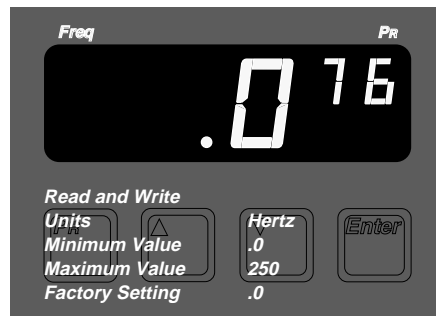

The value of this parameter is the command frequency when Preset Frequency 7 is selected.

**Parameter 77 -- Above  
Frequency  
Contact**

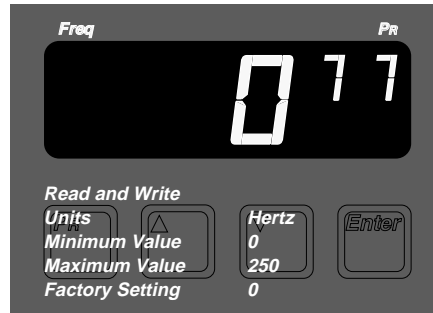

This parameter works in conjunction with terminals 10 and 11 of drive terminal block TB2. Terminals 10 and 11 allow an internal drive supplied at speed contact to be used in external circuits. The N.O. contact closes when the drive's output frequency reaches the command speed within  $\pm 0.5\%$  of maximum speed.

When Parameter 77 is set to zero, the parameter is turned off and the N.O. contact functions as described above.

When this parameter is set to a value other than zero, Parameter 77 provides a set point reference other than the drive's command speed. The N.O. contact will now close when the drive's output frequency is above the frequency set by Parameter 77. The contact will open when the drive's output frequency is at or below the frequency set by Parameter 77.

**Parameter 78 -- Traverse Period**

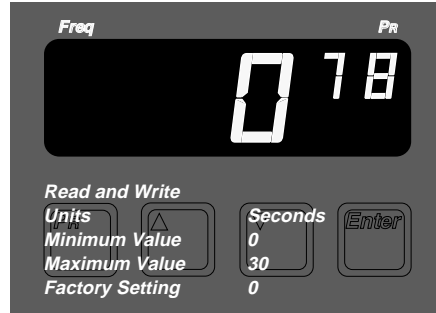

This parameter is not typically used in variable torque applications and should not be changed from its factory setting.

**Parameter 79 -- Maximum Traverse**

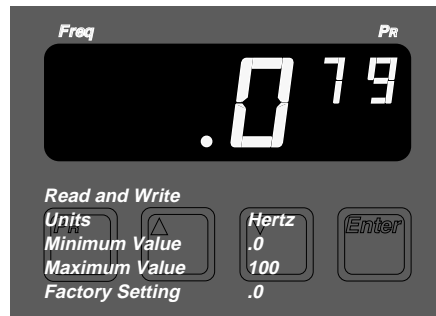

This parameter is not typically used in variable torque applications and should not be changed from its factory setting.

**Parameter 80 -- Inertia Compensation**



This parameter is not typically used in variable torque applications and should not be changed from its factory setting.

**Parameter 81 -- Soft Start/Stop Enable**

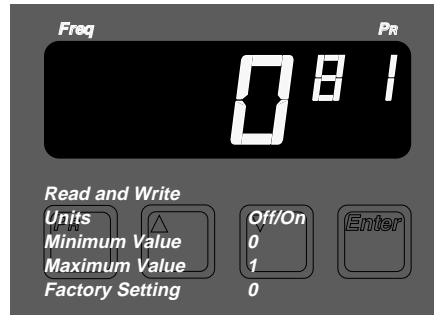

This parameter is currently not implemented.

**Parameter 82 -- Amp Limit Fault Enable**

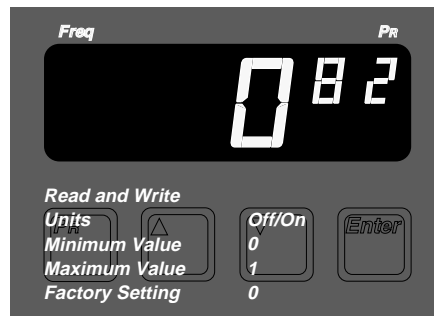

When enabled, exceeding the setting of Parameter 36 (MOPC) will cause a drive fault (F36 — Diagnostic Current Limit).

**Parameter 83 -- Run Boost**



**Important:** If Run Boost is greater than Start Boost (Parameter 48), the drive will fault and display F34 — Boost Error.

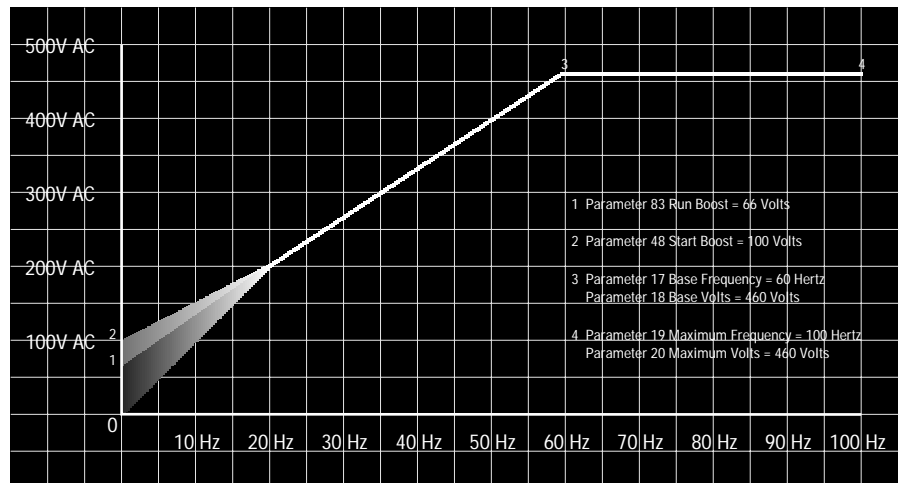

**Parameter 9 = 12 -- Run and Start Boost**

When Parameter 9 is set to **12** and this parameter is set to a value less than Start Boost but greater than zero, Run Boost will be enabled. Run Boost allows a secondary lower boost voltage to be used once the drive has reached command speed and the motor is no longer accelerating. When the motor is decelerating, the drive will use Run Boost, not Start Boost to reach the new command speed.

## Parameter 84 -- Analog Inverse

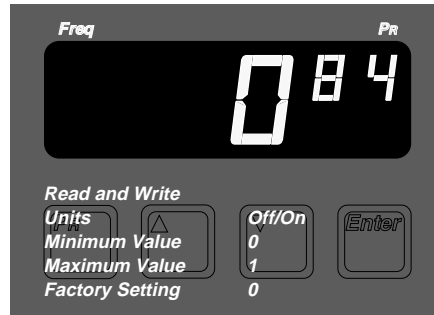

When this parameter is set to **0** (disabled), the 0-10V DC and 4-20mA analog inputs at terminal block TB2 in the drive will function as described in the User Manual.

When set to **1** (enabled), the 0-10V DC and 4-20mA analog inputs at TB2 will still function as described in the User Manual, but will produce an inverse signal. A 0V DC or 4mA signal will produce maximum drive output frequency as set by Parameter 19. A 10V DC or 20mA signal will produce minimum drive output frequency as set by Parameter 16.



**ATTENTION:** Unexpected machine acceleration can cause injury or death.

If Parameter 84 is enabled, a loss of the 4-20mA or 0-10V DC reference signal at drive terminal block TB2 will allow the drive to immediately accelerate to the maximum frequency set by Parameter 19.

Ensure that all control connection integrity is maintained and routinely inspected.

---

## Parameter 85 -- Restart Tries

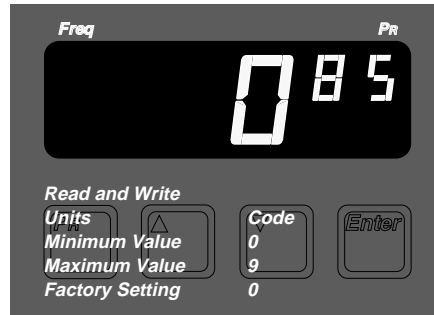

**Important:** Parameters 14 and 85 require two-wire control to allow an auto restart sequence to occur. 1336VT two-wire control requires that Logic Interface Option L1, L2 or L3 be installed in the drive.

With the exception of F13-F18 and F33, this parameter sets the number of times the drive will attempt to restart after a drive fault occurs. Drive restart attempts may be programmed from 0-9, but must be enabled by setting Parameter 14 to **1** (on).

When a fault occurs, an internal counter in drive logic is set to Restart Tries. Two timers will then start — A 20 second restart time delay and a 4 minute restart period.

When a fault occurs, the 20 second timer is started. When the 20 second delay is complete, an attempt to clear the fault is made. The internal counter is decremented 1 restart attempt, while the 4 minute period is decremented for the total restart time taken.

If the fault clears, the drive will restart. If more faults occur or the same fault reoccurs before the 4 minute timer expires, the 20 second timer is reset and the drive will again attempt to clear the fault.

This process will continue for the number of restart tries programmed until the 4 minute period expires. Once expired, fault F33 (Retries Exceeded) will occur and the drive must be reset manually.

## Parameters 86-89

Parameters 86-89 will store the last (4) faults that the drive has encountered. These buffers will be implemented in a cascading mode, that is when a different fault occurs, the following sequence will take place.

- Fault Buffer 0 will store the new fault.
- Fault Buffer 1 will store the fault from Fault Buffer 0.
- Fault Buffer 2 will store the fault from Fault Buffer 1.
- Fault Buffer 3 will store the fault from Fault Buffer 2.

— But only when a different fault occurs. Fault buffers will not cascade if the same fault occurs unless Parameter 86 has been programmed to zero.

**Important:** Parameters 86 and 4 will always display the same value. Parameters 86 and 4 will display the last fault received by the drive with one exception. Since Parameter 86 may also be programmed to store and display 0, if only one fault has occurred, Parameter 4 will display the value programmed into Parameter 86.

### Parameter 86 -- Fault Buffer 0



### Parameter 87 -- Fault Buffer 1

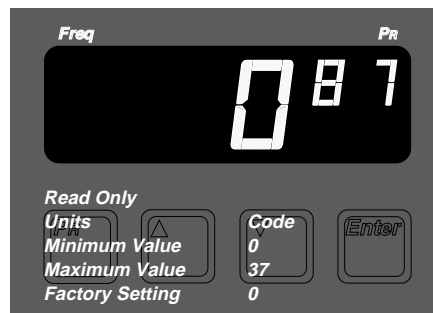

**Parameter 88 -- Fault Buffer 2**

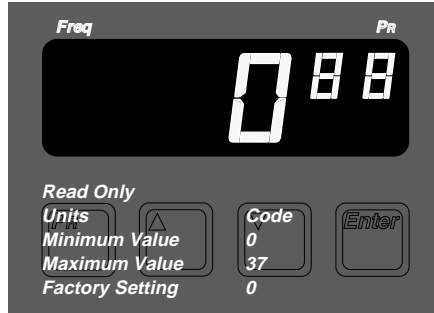

**Parameter 89 -- Fault Buffer 3**

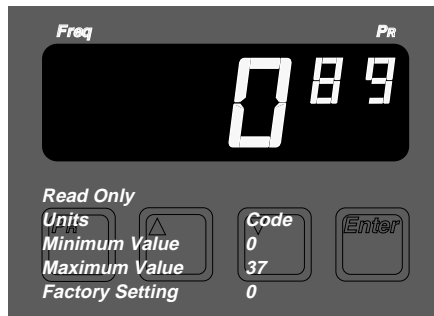

## Overload Current Settings

**Table 6 -- Overload Current Settings for 1336VT Drives**

---

Example: Drive rating = B003

Approximate Motor Full Load Current Rating = 3.05

Parameter 38 Setting = 61

---

Chapter 6  
Overload Current Settings

Table 6 -- Overload Current Settings for 1336VT Drives

Parameter 38 Setting	MOTOR FULL LOAD CURRENT RATING																
	B003	B005	B007	B010	B015	B020	B025	B030	B040	B050	B060	B075	B100	B125	B150	B200	B250
50	2.50	4.00	5.50	7.00	10.5	13.5	17.0	20.0	26.0	32.5	38.5	48	62	78	90	120	150
51	2.55	4.08	5.61	7.14	10.7	13.8	17.3	20.4	26.5	33.2	39.3	49	63	80	92	122	153
52	2.60	4.16	5.72	7.28	10.9	14.0	17.7	20.8	27.0	33.8	40.0	50	64	81	94	125	156
53	2.65	4.24	5.83	7.42	11.1	14.3	18.0	21.2	27.6	34.5	40.8	51	66	83	95	127	159
54	2.70	4.32	5.94	7.56	11.3	14.6	18.4	21.6	28.1	35.1	41.6	52	67	84	97	130	162
55	2.75	4.40	6.05	7.70	11.6	14.9	18.7	22.0	28.6	35.8	42.4	53	68	86	99	132	165
56	2.80	4.48	6.16	7.84	11.8	15.1	19.0	22.4	29.1	36.4	43.1	54	69	87	101	134	168
57	2.85	4.56	6.27	7.98	12.0	15.4	19.4	22.8	29.6	37.1	43.9	55	71	89	103	137	171
58	2.90	4.64	6.38	8.12	12.2	15.7	19.7	23.2	30.2	37.7	44.7	56	72	90	104	139	174
59	2.95	4.72	6.49	8.26	12.4	15.9	20.1	23.6	30.7	38.4	45.4	57	73	92	106	142	177
60	3.00	4.80	6.60	8.40	12.6	16.2	20.4	24.0	31.2	39.0	46.2	58	74	94	108	144	180
61	3.05	4.88	6.71	8.54	12.8	16.5	20.7	24.4	31.7	39.7	47.0	59	76	95	110	146	183
62	3.10	4.96	6.82	8.68	13.0	16.7	21.1	24.8	32.2	40.3	47.7	60	77	97	112	149	186
63	3.15	5.04	6.93	8.82	13.2	17.0	21.4	25.2	32.8	41.0	48.5	60	78	98	113	151	189
64	3.20	5.12	7.04	8.96	13.4	17.3	21.8	25.6	33.3	41.6	49.3	61	79	100	115	154	192
65	3.25	5.20	7.15	9.10	13.7	17.6	22.1	26.0	33.8	42.3	50.1	62	81	101	117	156	195
66	3.30	5.28	7.26	9.24	13.9	17.8	22.4	26.4	34.3	42.9	50.8	63	82	103	119	158	198
67	3.35	5.36	7.37	9.38	14.1	18.1	22.8	26.8	34.8	43.6	51.6	64	83	105	121	161	201
68	3.40	5.44	7.48	9.52	14.3	18.4	23.1	27.2	35.4	44.2	52.4	65	84	106	122	163	204
69	3.45	5.52	7.59	9.66	14.5	18.6	23.5	27.6	35.9	44.9	53.1	66	86	108	124	166	207
70	3.50	5.60	7.70	9.80	14.7	18.9	23.8	28.0	36.4	45.5	53.9	67	87	109	126	168	210
71	3.55	5.68	7.81	9.94	14.9	19.2	24.1	28.4	36.9	46.2	54.7	68	88	111	128	170	213
72	3.60	5.76	7.92	10.08	15.1	19.4	24.5	28.8	37.4	46.8	55.4	69	89	112	130	173	216
73	3.65	5.84	8.03	10.22	15.3	19.7	24.8	29.2	38.0	47.5	56.2	70	91	114	131	175	219
74	3.70	5.92	8.14	10.36	15.5	20.0	25.2	29.6	38.5	48.1	57.0	71	92	115	133	178	222
75	3.75	6.00	8.25	10.50	15.8	20.3	25.5	30.0	39.0	48.8	57.8	72	93	117	135	180	225
76	3.80	6.08	8.36	10.64	16.0	20.5	25.8	30.4	39.5	49.4	58.5	73	94	119	137	182	228
77	3.85	6.16	8.47	10.78	16.2	20.8	26.2	30.8	40.0	50.1	59.3	74	95	120	139	185	231
78	3.90	6.24	8.58	10.92	16.4	21.1	26.5	31.2	40.6	50.7	60.1	75	97	122	140	187	234
79	3.95	6.32	8.69	11.06	16.6	21.3	26.9	31.6	41.1	51.4	60.8	76	98	123	142	190	237
80	4.00	6.40	8.80	11.20	16.8	21.6	27.2	32.0	41.6	52.0	61.6	77	99	125	144	192	240
81	4.05	6.48	8.91	11.34	17.0	21.9	27.5	32.4	42.1	52.7	62.4	78	100	126	146	194	243
82	4.10	6.56	9.02	11.48	17.2	22.1	27.9	32.8	42.6	53.3	63.1	79	102	128	148	197	246
83	4.15	6.64	9.13	11.62	17.4	22.4	28.2	33.2	43.2	54.0	63.9	80	103	129	149	199	249
84	4.20	6.72	9.24	11.76	17.6	22.7	28.6	33.6	43.7	54.6	64.7	81	104	131	151	202	252
85	4.25	6.80	9.35	11.90	17.9	23.0	28.9	34.0	44.2	55.3	65.5	82	105	133	153	204	255
86	4.30	6.88	9.46	12.04	18.1	23.2	29.2	34.4	44.7	55.9	66.2	83	107	134	155	206	258
87	4.35	6.96	9.57	12.18	18.3	23.5	29.6	34.8	45.2	56.6	67.0	84	108	136	157	209	261
88	4.40	7.04	9.68	12.32	18.5	23.8	29.9	35.2	45.8	57.2	67.8	84	109	137	158	211	264
89	4.45	7.12	9.79	12.46	18.7	24.0	30.3	35.6	46.3	57.9	68.5	85	110	139	160	214	267
90	4.50	7.20	9.90	12.60	18.9	24.3	30.6	36.0	46.8	58.5	69.3	86	112	140	162	216	270
91	4.55	7.28	10.01	12.74	19.1	24.6	30.9	36.4	47.3	59.2	70.1	87	113	142	164	218	273
92	4.60	7.36	10.12	12.88	19.3	24.8	31.3	36.8	47.8	59.8	70.8	88	114	144	166	221	276
93	4.65	7.44	10.23	13.02	19.5	25.1	31.6	37.2	48.4	60.5	71.6	89	115	145	167	223	279
94	4.70	7.52	10.34	13.16	19.7	25.4	32.0	37.6	48.9	61.1	72.4	90	117	147	169	226	282
95	4.75	7.60	10.45	13.30	20.0	25.7	32.3	38.0	49.4	61.8	73.2	91	118	148	171	228	285
96	4.80	7.68	10.56	13.44	20.2	25.9	32.6	38.4	49.9	62.4	73.9	92	119	150	173	230	288
97	4.85	7.76	10.67	13.58	20.4	26.2	33.0	38.8	50.4	63.1	74.7	93	120	151	175	233	291
98	4.90	7.84	10.78	13.72	20.6	26.5	33.3	39.2	51.0	63.7	75.5	94	122	153	176	235	294
99	4.95	7.92	10.89	13.86	20.8	26.7	33.7	39.6	51.5	64.4	76.2	95	123	154	178	238	297
100	5.00	8.00	11.00	14.00	21.0	27.0	34.0	40.0	52.0	65.0	77.0	96	124	156	180	240	300
101	5.05	8.08	11.11	14.14	21.2	27.3	34.3	40.4	52.5	65.7	77.8	97	125	158	182	242	303
102	5.10	8.16	11.22	14.28	21.4	27.5	34.7	40.8	53.0	66.3	78.5	98	127	159	184	245	306
103	5.15	8.24	11.33	14.42	21.6	27.8	35.0	41.2	53.6	67.0	79.3	99	128	161	185	247	309
104	5.20	8.32	11.44	14.56	21.8	28.1	35.4	41.6	54.1	67.6	80.1	100	129	162	187	250	312
105	5.25	8.40	11.55	14.70	22.1	28.4	35.7	42.0	54.6	68.3	80.9	101	130	164	189	252	315
106	5.30	8.48	11.66	14.84	22.3	28.6	36.0	42.4	55.1	68.9	81.6	102	131	165	191	254	318
107	5.35	8.56	11.77	14.98	22.5	28.9	36.4	42.8	55.6	69.6	82.4	103	133	167	193	257	321
108	5.40	8.64	11.88	15.12	22.7	29.2	36.7	43.2	56.2	70.2	83.2	104	134	169	194	259	324
109	5.45	8.72	11.99	15.26	22.9	29.4	37.1	43.6	56.7	70.9	83.9	105	135	170	196	262	327
110	5.50	8.80	12.10	15.40	23.1	29.7	37.4	44.0	57.2	71.5	84.7	106	136	172	198	264	330
111	5.55	8.88	12.21	15.54	23.3	30.0	37.7	44.4	57.7	72.2	85.5	107	138	173	200	266	333
112	5.60	8.96	12.32	15.68	23.5	30.2	38.1	44.8	58.2	72.8	86.2	108	139	175	202	269	336
113	5.65	9.04	12.43	15.82	23.7	30.5	38.4	45.2	58.8	73.5	87.0	109	140	177	203	271	339
114	5.70	9.12	12.54	15.96	23.9	30.8	38.8	45.6	59.3	74.1	87.8	109	141	178	205	274	342
115	5.75	9.20	12.65	16.10	24.2	31.1	39.1	46.0	59.8	74.8	88.6	110	143	179	207	276	345

## % Load/Current Conversion

**Table 7 -- % Load/Current Conversion for 1336VT Drives**

Example: Parameter 2 = 52

Drive rating = B003

Rated Power = 52% = 50% + 2% = 2.5 + 0.1 = 2.6 Amps

%	B003	B005	B007	B010	B015	B020	B025	B030	B040	B050	B060	B075	B100	B125	B150	B200	B250
1	0.1	0.1	0.1	0.1	0.2	0.3	0.3	0.4	0.5	0.7	0.8	1.0	1.2	1.6	1.8	2.4	3.0
2	0.1	0.2	0.2	0.3	0.4	0.5	0.7	0.8	1.0	1.3	1.5	1.9	2.5	3.1	3.6	4.8	6.0
3	0.2	0.2	0.3	0.4	0.6	0.8	1.0	1.2	1.6	2.0	2.3	2.9	3.7	4.7	5.4	7.2	9.0
4	0.2	0.3	0.4	0.6	0.8	1.1	1.4	1.6	2.1	2.6	3.1	3.8	5.0	6.2	7.2	9.6	12.0
5	0.3	0.4	0.6	0.7	1.1	1.4	1.7	2.0	2.6	3.3	3.9	4.8	6.2	7.8	9.0	12.0	15.0
6	0.3	0.5	0.7	0.8	1.3	1.6	2.0	2.4	3.1	3.9	4.6	5.8	7.4	9.4	10.8	14.4	18.0
7	0.4	0.6	0.8	1.0	1.5	1.9	2.4	2.8	3.6	4.6	5.4	6.7	8.7	10.9	12.6	16.8	21.0
8	0.4	0.6	0.9	1.1	1.7	2.2	2.7	3.2	4.2	5.2	6.2	7.7	9.9	12.5	14.4	19.2	24.0
9	0.5	0.7	1.0	1.3	1.9	2.4	3.1	3.6	4.7	5.9	6.9	8.6	11.2	14.0	16.2	21.6	27.0
10	0.5	0.8	1.1	1.4	2.1	2.7	3.4	4.0	5.2	6.5	7.7	9.6	12.4	15.6	18.0	24.0	30.0
20	1.0	1.6	2.2	2.8	4.2	5.4	6.8	8.0	10.4	13.0	15.4	19.2	24.8	31.2	36.0	48.0	60.0
30	1.5	2.4	3.3	4.2	6.3	8.1	10.2	12.0	15.6	19.5	23.1	28.8	37.2	46.8	54.0	72.0	90.0
40	2.0	3.2	4.4	5.6	8.4	10.8	13.6	16.0	20.8	26.0	30.8	38.4	49.6	62.4	72.0	96.0	120.0
50	2.5	4.0	5.5	7.0	10.5	13.5	17.0	20.0	26.0	32.5	38.5	48.0	62.0	78.0	90.0	120.0	150.0
60	3.0	4.8	6.6	8.4	12.6	16.2	20.4	24.0	31.2	39.0	46.2	57.6	74.4	93.6	108.0	144.0	180.0
70	3.5	5.6	7.7	9.8	14.7	18.9	23.8	28.0	36.4	45.5	53.9	67.2	86.8	109.2	126.0	168.0	210.0
80	4.0	6.4	8.8	11.2	16.8	21.6	27.2	32.0	41.6	52.0	61.6	76.8	99.2	124.8	144.0	192.0	240.0
90	4.5	7.2	9.9	12.6	18.9	24.3	30.6	36.0	46.8	58.5	69.3	86.4	111.6	140.4	162.0	216.0	270.0
100	5.0	8.0	11.0	14.0	21.0	27.0	34.0	40.0	52.0	65.0	77.0	96.0	124.0	156.0	180.0	240.0	300.0
110	5.5	8.8	12.1	15.4	23.1	29.7	37.4	44.0	57.2	71.5	84.7	105.6	136.4	171.6	198.0	264.0	330.0

## % Power/kW Conversion

**Table 8 -- % Power/kW Conversion for 1336VT Drives**

Example: Parameter 3 = 36

Drive rating = B005

Rated Power = 36% = 30% + 6% = 1.1 + 0.2 = 1.3 kW

%	B003	B005	B007	B010	B015	B020	B025	B030	B040	B050	B060	B075	B100	B125	B150	B200	B250
1	0.02	0.04	0.06	0.07	0.11	0.15	0.19	0.22	0.30	0.37	0.45	0.56	0.75	0.93	1.12	1.49	1.87
2	0.04	0.07	0.11	0.15	0.22	0.30	0.37	0.45	0.60	0.75	0.90	1.12	1.49	1.87	2.24	2.98	3.73
3	0.07	0.11	0.17	0.22	0.34	0.45	0.56	0.67	0.90	1.12	1.34	1.68	2.24	2.80	3.36	4.48	5.60
4	0.09	0.15	0.22	0.30	0.45	0.60	0.75	0.90	1.19	1.49	1.79	2.24	2.98	3.73	4.48	5.97	7.46
5	0.11	0.19	0.28	0.37	0.56	0.75	0.93	1.12	1.49	1.87	2.24	2.80	3.73	4.66	5.60	7.46	9.33
6	0.13	0.22	0.34	0.45	0.67	0.90	1.12	1.34	1.79	2.24	2.69	3.36	4.48	5.60	6.71	8.95	11.19
7	0.16	0.26	0.39	0.52	0.78	1.04	1.31	1.57	2.09	2.61	3.13	3.92	5.22	6.53	7.83	10.44	13.06
8	0.18	0.30	0.45	0.60	0.90	1.19	1.49	1.79	2.39	2.98	3.58	4.48	5.97	7.46	8.95	11.94	14.92
9	0.20	0.34	0.50	0.67	1.01	1.34	1.68	2.01	2.69	3.36	4.03	5.04	6.71	8.39	10.07	13.43	16.79
10	0.22	0.37	0.56	0.75	1.12	1.49	1.87	2.24	2.98	3.73	4.48	5.60	7.46	9.33	11.19	14.92	18.65
20	0.45	0.75	1.12	1.49	2.24	2.98	3.73	4.48	5.97	7.46	8.95	11.19	14.92	18.65	22.38	29.84	37.30
30	0.67	1.12	1.68	2.24	3.36	4.48	5.60	6.71	8.95	11.19	13.43	16.79	22.38	27.98	33.57	44.76	55.95
40	0.90	1.49	2.24	2.98	4.48	5.97	7.46	8.95	11.94	14.92	17.90	22.38	29.84	37.30	44.76	59.68	74.60
50	1.12	1.87	2.80	3.73	5.60	7.46	9.33	11.19	14.92	18.65	22.38	27.98	37.30	46.63	55.95	74.60	93.25
60	1.34	2.24	3.36	4.48	6.71	8.95	11.19	13.43	17.90	22.38	26.86	33.57	44.76	55.95	67.14	89.52	111.90
70	1.57	2.61	3.92	5.22	7.83	10.44	13.06	15.67	20.89	26.11	31.33	39.17	52.22	65.28	78.33	104.44	130.55
80	1.79	2.98	4.48	5.97	8.95	11.94	14.92	17.90	23.87	29.84	35.81	44.76	59.68	74.60	89.52	119.36	149.20
90	2.01	3.36	5.04	6.71	10.07	13.43	16.79	20.14	26.86	33.57	40.28	50.36	67.14	83.93	100.71	134.28	167.85
100	2.24	3.73	5.60	7.46	11.19	14.92	18.65	22.38	29.84	37.30	44.76	55.95	74.60	93.25	111.90	149.20	186.50
110	2.46	4.10	6.15	8.21	12.31	16.41	20.52	24.62	32.82	41.03	49.24	61.55	82.06	102.58	123.09	164.12	205.15

## Local and Serial Port Parameter Settings Firmware Version 1.01-3.01

**Table 9 -- Parameter List for Parameters 0 to 50**

Parameters 0 to 50 can be accessed through either the local or serial port.

Parameter Number	Parameter Text	Units	Local Programming Panel Min/Max Values	Serial Port Min/Max Values	Factory Setting
0	PARAMETER MODE	None	0/0	0/0	0
1	OUTPUT VOLTS	Volts	0/575	0/575	0
2	OUTPUT CURRENT	% of Rated Output Current	0/200	0/200	0
3	OUTPUT POWER	% of Rated Output Power	0/200	0/200	0
4	LAST FAULT	Code	0/37	0/37	0
5	FREQUENCY SELECT 1	Code	0/5	0/5	0
6	FREQUENCY SELECT 2	Code	0/5	0/5	0
7	ACCEL TIME 1	Seconds	0/600	0.00/600.00	5
8	DECEL TIME 1	Seconds	0/600	0.00/600.00	5
9	DC BOOST SELECT	Code	0/1	0/12	2
10	STOP SELECT	Code	0/2	0/2	0
11	DECEL FREQUENCY HOLD	Off/On	0/1	0/1	0
12	DC HOLD TIME	Seconds	0/15	0/15	0
13	DC HOLD VOLTS	Volts	0/115	0/115	0
14	AUTO RESTART	Off/On	0/1	0/1	1
15	FACTORY SET -- DO NOT CHANGE	None	0/0	0/0	0
16	MINIMUM FREQUENCY	Hertz	0/120	0/120	0
17	BASE FREQUENCY	Hertz	40/120	40/120	60
18	BASE VOLTS	Volts	115/575	115/575	460
19	MAXIMUM FREQUENCY	Hertz	40/250	40/250	60
20	MAXIMUM VOLTS	Volts	115/575	115/575	460
21	LOCAL RUN	Off/On	0/1	0/1	1
22	LOCAL REVERSE	Off/On	0/1	0/1	1
23	LOCAL JOG	Off/On	0/1	0/1	1
24	JOG FREQUENCY	Hertz	.0/120	0.00/120.00	.0
25	ANALOG OUTPUT	Code	0/1	0/1	0
26	PRESET/2ND ACCEL	Code	0/1	0/1	0
27	PRESET FREQUENCY 1	Hertz	.0/250	0.00/250.00	.0
28	PRESET FREQUENCY 2	Hertz	.0/250	0.00/250.00	.0
29	PRESET FREQUENCY 3	Hertz	.0/250	0.00/250.00	.0

**Table 9 -- Parameter List for Parameters 0 to 50 (cont.)**

Parameter Number	Parameter Text	Units	Local Programming Panel Min/Max Values	Serial Port Min/Max Values	Factory Setting
30	ACCEL TIME 2	Seconds	0/600	0.00/600.00	5
31	DECEL TIME 2	Seconds	0/600	0.00/600.00	5
32	SKIP FREQUENCY 1	Hertz	0/250	0/250	250
33	SKIP FREQUENCY 2	Hertz	0/250	0/250	250
34	SKIP FREQUENCY 3	Hertz	0/250	0/250	250
35	SKIP FREQUENCY BAND	Hertz	0/15	0/15	0
36	MOPC	% of Rated Output Current	50/115	50/115	115
37	SERIAL BAUD RATE	Code	0/1	0/1	1
38	OVERLOAD CURRENT	% of Rated Output Current	50/115	50/115	100
39	FAULT CLEAR	Off/On	0/1	0/1	1
40	POWER FAULT	Off/On	0/1	0/1	0
41	MOTOR TYPE	Code	0/2	0/2	0
42	SLIP COMPENSATION	Hertz	.0/5.0	0.00/5.00	.0
43	DWELL FREQUENCY	Hertz	0/120	0/120	0
44	DWELL TIME	Seconds	0/10	0/10	0
45	PWM FREQUENCY	kHZ	.40/2.00	0.40/2.00	.40
46	PULSE SCALE FACTOR	Ratio	1/255	1/255	64
47	LANGUAGE	Code	0/5	0/5	0
48	START BOOST	Volts	0/115	0/115	0
49	BREAK FREQ	Hertz	0/120	0/120	0
50	BREAK VOLTS	Volts	0/230	0/230	0

## Serial Port Parameter Settings Firmware Version 1.01-3.01

**Table 10 -- Parameter List for Parameters 51 to 69**

Parameters 51 to 69 can be accessed only through the serial port.

Parameter Number	Parameter Text	Units	Serial Port Min/Max Values	Factory Setting
51	CLEAR FAULT	Code	0/255	0
52	INPUT FAULT	Code	0/99	---
53	DRIVE FAULT	Code	0/99	---
54	LOCAL INPUT	Byte	0/255	---
55	REMOTE INPUT	Byte	0/255	---
56	SERIAL INPUT	Byte	0/255	---
57	SERIAL MASK	Byte	0/255	0
58	DRIVE COMMAND	Byte	0/255	---
59	DRIVE STATUS	Byte	0/255	---
60	DRIVE ALARM	Byte	0/255	---
61	DRIVE TYPE	Byte	0/255	---
62	FREQUENCY SOURCE	Code	0/13	---
63	PULSE INPUT	Hertz	0.00/250.00	---
64	SERIAL FREQUENCY	Hertz	0.00/250.00	0.00
65	FREQUENCY COMMAND	Hertz	0.00/250.00	---
66	OUTPUT FREQUENCY	Hertz	0.00/250.00	---
67	OUTPUT PULSES	1 Rev/256	0/65535/256	---
68	SERIAL PASSWORD	Code	0/9999	0
69	REVERSE STATUS	Code	0/1	0

## Local and Serial Port Parameter Settings Firmware Version 2.01 and 3.01

**Table 11 -- Parameter List for Parameters 70 to 89**

Parameters 70 to 89 are local and serial port parameters that may only be accessed with Firmware Version 2.01 and 3.01.

Parameter Number	Parameter Text	Units	Local Programming Panel Min/Max Values	Serial Port Min/Max Values	Factory Setting
70	BASE DRIVER BOARD VERSION	Code	---	---	---
71	CONTROL BOARD VERSION	Code	---	---	---
72	ACTIVATE PARAMETERS 73-76	Off/On	0/1	0/1	0
73	PRESET FREQUENCY 4	Hertz	.0/250	0.00/250.00	.0
74	PRESET FREQUENCY 5	Hertz	.0/250	0.00/250.00	.0
75	PRESET FREQUENCY 6	Hertz	.0/250	0.00/250.00	.0
76	PRESET FREQUENCY 7	Hertz	.0/250	0.00/250.00	.0
77	ABOVE FREQUENCY CONTACT	Hertz	0/250	0/250	0
78	TRAVERSE PERIOD	Seconds	0/30	0.00/30.00	0
79	MAXIMUM TRAVERSE	Hertz	.0/100	0.00/100.00	.0
80	INERTIA COMPENSATION	Hertz	.0/20.0	0.00/20.00	.0
81	SOFT START/STOP ENABLE	Off/On	---	---	---
82	AMP LIMIT FAULT ENABLE	Off/On	0/1	0/1	0
83	RUN BOOST	Volts	0/115	0/115	0
84	ANALOG INVERSE	Off/On	0/1	0/1	0
85	RESTART TRIES	Code	0/9	0/9	0
86	FAULT BUFFER 0	Code	0/37	0/37	---
87	FAULT BUFFER 1	Code	0/37	0/37	---
88	FAULT BUFFER 2	Code	0/37	0/37	---
89	FAULT BUFFER 3	Code	0/37	0/37	---

## Start and Run Boost Settings

The following setup procedure may be used to maximize starting torque and minimize motor heating. The procedure is written for users who have the optional Handheld Terminal (HHT) or a Control Panel installed, and who are not using a 2-wire drive control scheme. For users without the optional HHT or Control Panel, respective external commands and signals must be substituted to simulate the operation of the HHT or a Control Panel.



**ATTENTION:** Become familiar with the equipment and read through the wiring, speed selection and adjustment sections of the User Manual before attempting to perform this setup procedure. Adjustments in this setup procedure will be made under load conditions with power applied both to the drive and motor.

Exercise extreme care when performing any drive programming. Failure to do so may result in equipment damage.

---

### Important:

1. Power must be applied to the drive when viewing or changing 1336VT parameters. Previous programming may effect the drive status when power is applied.
2. If option L1, L2 or L3 is installed, remote start circuits may be connected to TB3 on the Interface Board. Confirm that all circuits are in a de-energized state before applying power.
3. If you cannot complete a procedure, immediately refer to Chapter 10 — Fault Codes in the User Manual. Do not proceed. Determine the cause of the problem and correct the problem first, then return to the startup procedure.

## DC Boost

Usually increased starting torque requires more DC boost. High boost may produce unnecessary current at low frequency and contribute to motor overheating. Excessive boost may force the drive into MOPC resulting in poor drive performance. The optimum DC boost is the lowest level that will permit satisfactory starting torque in a properly sized motor and drive application.

## Start and Run Boost Settings

By using a combination of start and run boost, the following procedure provides a selectable DC boost voltage to the motor at low drive frequency. The correct boost combination will allow the drive and motor to adapt to the different starting torque conditions encountered in both low and high HP applications, while helping to prevent motor overheating.

## Parameters Used

Output Current — Parameter 2  
DC Boost Select — Parameter 9  
Start Boost — Parameter 48  
Preset Frequency — Parameters 27, 28, 29, 73, 74, 75 or 76  
Run Boost — Parameter 83

## Procedure

The following setup procedure is performed with the motor connected to the load. To optimize starting torque and help prevent motor overheating, perform all seven steps. Steps 1-3 are performed at low frequency settings (below 10 Hz) — Steps 4-7 at the highest operating frequency (typically 60 Hz).

1. Set DC boost (Parameter 9) to its factory setting of **2**, then set the local speed pot or one of the preset frequencies to a value below 10 Hz.

Start the drive.

The motor should accelerate to the value set.

2. If the motor does not accelerate smoothly, DC boost must be added to the motor. Gradually increase DC boost (Parameter 9) from **2** to **10** until set speed is reached.

**Procedure (cont.)**

100% Drive Output Current										
75% Drive Output Current										
50% Drive Output Current										
25% Drive Output Current										
Parameter 9 = DC Boost =	2 0V	3 6V	4 12V	5 18V	6 24V	7 30V	8 36V	9 42V	10 48V	

3. Once smooth acceleration is obtained, set DC boost (Parameter 9) to **2**, then **3, 4, 5, 6, 7, 8, 9** and finally **10**. Monitor and record drive output current (Parameter 2) at each setting in the graph above. Compare the values to those provided in the graph below.

- If boost voltage is too low, the motor will be under excited and not be able to develop full torque.
- If boost voltage is too high, motor windings may saturate and cause difficulty in starting.
- The optimum setting for developing high motor torque is shown in the graphs below.

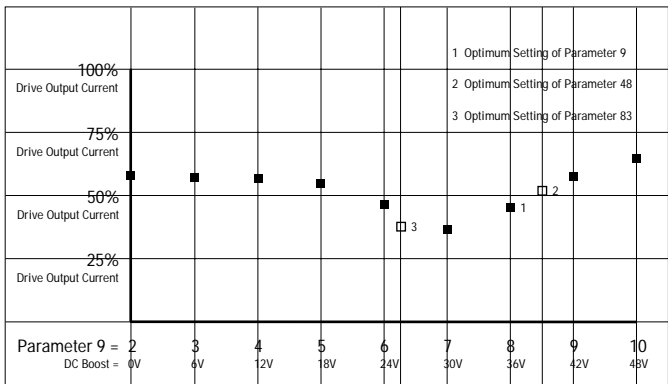

Typical Low HP Curve

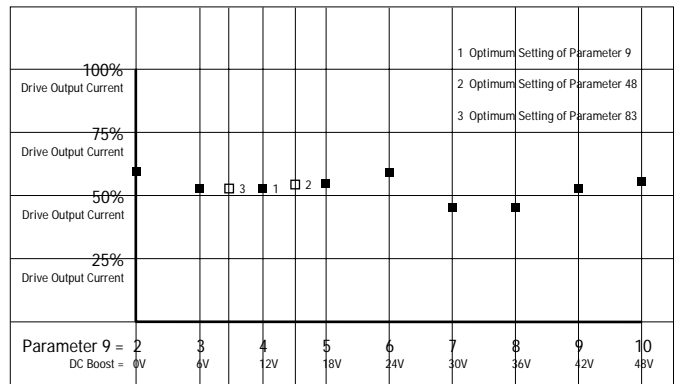

Typical High HP Curve

**Procedure (cont.)**

4. Stop the drive and set drive frequency to the highest operating point required by the application (typically 60 Hz).
  
5. Construct a custom start and run DC boost curve by setting Parameter 9 to **12**.
  - Set start boost (Parameter 48) to a value that will be 3 volts greater than the DC boost set in step 3.
  - Set run boost (Parameter 83) to  $\frac{2}{3}$  of the value of Parameter 48.
  
6. Start the drive.

The motor should accelerate smoothly to the maximum frequency. If not, starting torque may be optimized by increasing start boost (Parameter 48) in 1 volt increments.

7. Run the drive at the lowest speed required for the application. Monitor drive output current (Parameter 2 ) and record its value along the zero axis on the graph below.
  - Decrease then increase the run boost value set in Step 5 from -4 to +4V in 1V increments.
  - Monitor and record drive output current (Parameter 2) at each setting in the graph below.
  - To allow the motor to run cooler, set the final run boost value (Parameter 83) to the value that produces the lowest current.

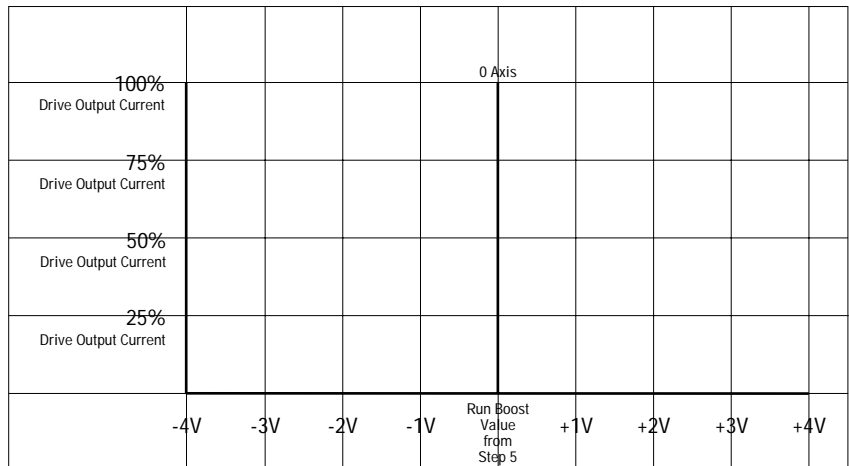



Allen-Bradley, a Rockwell Automation Business, has been helping its customers improve productivity and quality for more than 90 years. We design, manufacture and support a broad range of automation products worldwide. They include logic processors, power and motion control devices, operator interfaces, sensors and a variety of software. Rockwell is one of the world's leading technology companies.



## Worldwide representation.

Argentina • Australia • Austria • Bahrain • Belgium • Brazil • Bulgaria • Canada • Chile • China, PRC • Colombia • Costa Rica • Croatia • Cyprus • Czech Republic • Denmark • Ecuador • Egypt • El Salvador • Finland • France • Germany • Greece • Guatemala • Honduras • Hong Kong • Hungary • Iceland • India • Indonesia • Ireland • Israel • Italy • Jamaica • Japan • Jordan • Korea • Kuwait • Lebanon • Malaysia • Mexico • Netherlands • New Zealand • Norway • Pakistan • Peru • Philippines • Poland • Portugal • Puerto Rico • Qatar • Romania • Russia-CIS • Saudi Arabia • Singapore • Slovakia • Slovenia • South Africa, Republic • Spain • Sweden • Switzerland • Taiwan • Thailand • Turkey • United Arab Emirates • United Kingdom • United States • Uruguay • Venezuela • Yugoslavia

Allen-Bradley Headquarters, 1201 South Second Street, Milwaukee, WI 53204 USA, Tel: (1) 414 382-2000 Fax: (1) 414 382-4444