

## Power Cables

Catalog Number 2090-CPBM6DF-16AAxx,  
 2090-CPWM6DF-16AAxx, 2090-DANPT-16Sxx,  
 2090-XXNPH-16Sxx, 2090-XXNPHF-14Sxx, 2090-MCNPMP-6Sxx,  
 2090-XXNPMP-8Sxx, 2090-XXNPMF-10Sxx,  
 2090-XXNPMF-14Sxx, 2090-XXNPMF-16Sxx, 2090-XXNPN-16Sxx,  
 2090-XXNPT-16Sxx, 2090-XXNPY-16Sxx

<b>Topic</b>	<b>Page</b>
Before You Begin	1
Cable Installation Guidelines	2
Schematics and Connector Pinouts for Power Cables	3
2090-CPBM6DF-16AAxx	3
2090-CPWM6DF-16AAxx	4
2090-DANPT-16Sxx	4
2090-MCNPMP-6Sxx, 2090-XXNPMP-8Sxx, 2090-XXNPH-16Sxx, 2090-XXNPHF-14Sxx	5
2090-XXNPMF-10Sxx	5
2090-XXNPMF-14Sxx, 2090-XXNPMF-16Sxx	6
2090-XXNPMP-10Sxx, 2090-XXNPMP-14Sxx, 2090-XXNPMP-16Sxx	6
2090-XXNPN-16Sxx	7
2090-XXNPT-16Sxx	7
2090-XXNPY-16Sxx	7

### About This Publication

This publication provides cable schematics with wire color and connector pinouts for power cables used with Kinetix Motion Control products.

### Before You Begin

The Kinetix Motion Control Selection Guide, publication GMC-SG001, contains information on cable compatibility with specific drives and motors. It also provides information on the bend offset and bend radius for each cable. Refer to your drive manual for instructions to correctly interface the cables in this document to your drive and motor combination.

These publications are available from your local Rockwell Automation sales office or online at <http://www.literature.rockwellautomation.com>).

## Cable Installation Guidelines

Cables are stored and shipped in a coil, and they will retain this shape unless you allow the cable to straighten itself. To straighten a cable, hang a short cable from its mid-point or lay a long cable on the floor in a straight line. Any coiling that persists in the cable should relax within the next twenty-four hours. Doing this results in a cable that is easier to install.

---

**WARNING**

To avoid the hazard of electrical shock, ensure shielded power cables are grounded at a minimum of one point. Factory supplied cables have the following design features that prevent the build-up of electrical energy.

- the overall braid bonded to the connector housing,
- an exposed section of the overall braid, or
- a ground wire connected to the overall braid.

If the exposed cable braid or a ground wire is present, it should be connected to the power cable clamp, housing, or another suitable chassis ground on the drive.

Failure to observe these safety procedures could result in personal injury or equipment damage.

---

**WARNING**

Servo drive power must be turned off before connecting or disconnecting the cables to the motor, and if a cable is left disconnected at the motor end. Arcing or unexpected motion could occur if the brake, feedback, or power cables are connected or disconnected while power is applied to the servo drive.

Failure to observe these safety procedures could result in personal injury or damage to the motor and equipment.

---

**ATTENTION**

The examples in this publication show all the available connections, some of which may not be appropriate for your specific installation. Refer to your drive installation or user manual for wiring examples appropriate to your drive and motor application.

Do not connect unused wires. These unused wires may be trimmed and finished as necessary to prevent accidental contact with other wires or wire shields, or with a ground connection.

Failure to observe these safety procedures could result in personal injury or damage to the motor and equipment.

---

**ATTENTION**



Do not tightly gather or coil the excess length of a power cable. Heat is generated within a cable whenever power is applied. Always position a power cable so it may freely dissipate any heat.

A power cable should not be coiled, except for temporary use when building or testing a machine. If you temporarily coil a power cable, you must also derate the cable to meet local code or follow a authoritative directive, such as Engineering Section 310.15(C) of the NEC Handbook.

Failure to observe these safety procedures could result in personal injury or equipment damage.

Before bending a cable, verify that the correct offset from the connector is provided. This offset should be equal to or greater than one times (1x) the cable diameter.

All cables have a specified bend radius, and cables should not be bent with a radius that is tighter than the specified bend radius.

- Cables have a static or one-time bend radius of ten times (10x) the cable diameter.
- Flex cables have an operational bend radius of twelve times (12x) the cable diameter.

You may identify the connections for a cable by attaching a label around the outer insulation of each wire adjacent to the drive connection.

## Schematics and Connector Pinouts for Power Cables

These diagrams detail cable wiring and pinouts.

### 2090-CPBM6DF-16AAxx

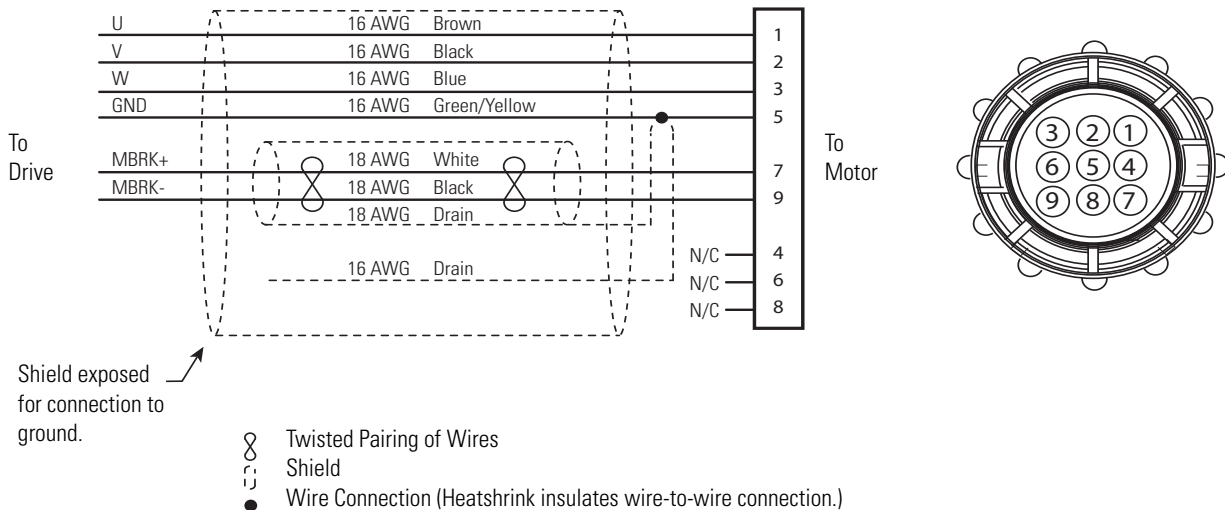

### 2090-CPWM6DF-16AAxx

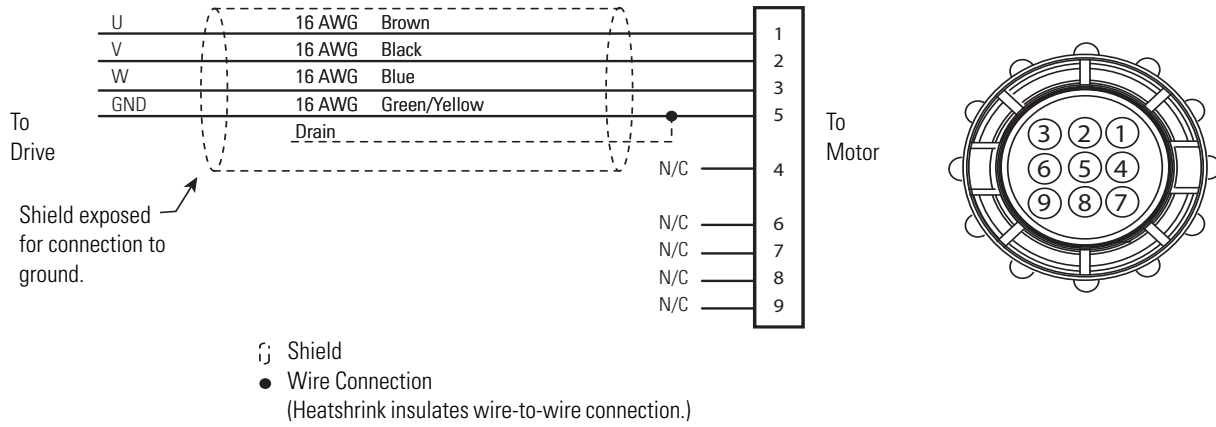

### 2090-DANPT-16Sxx

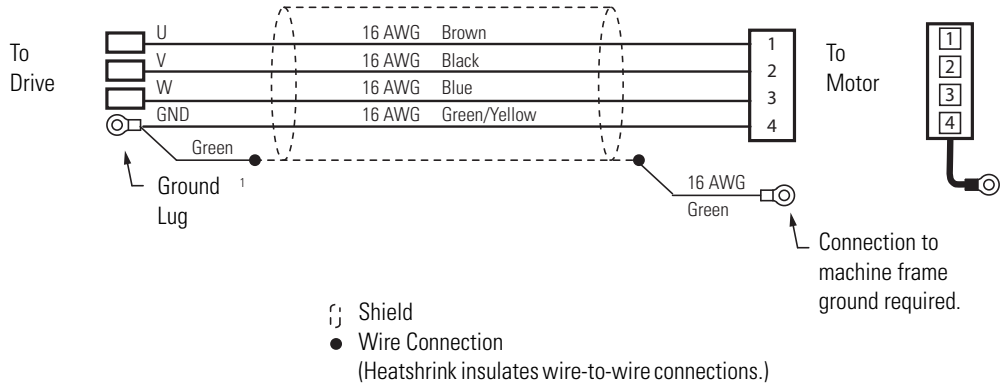

1 Ground lug is located on the heatsink of on the Ultra 1500 drive. Do NOT connect this wire to the N Terminal (DC Bus Neg) on the Ultra 1500 drive.

**2090-MCNPMP-6Sxx, 2090-XXNPMP-8Sxx, 2090-XXNPH-16Sxx,  
2090-XXNPHF-14Sxx**

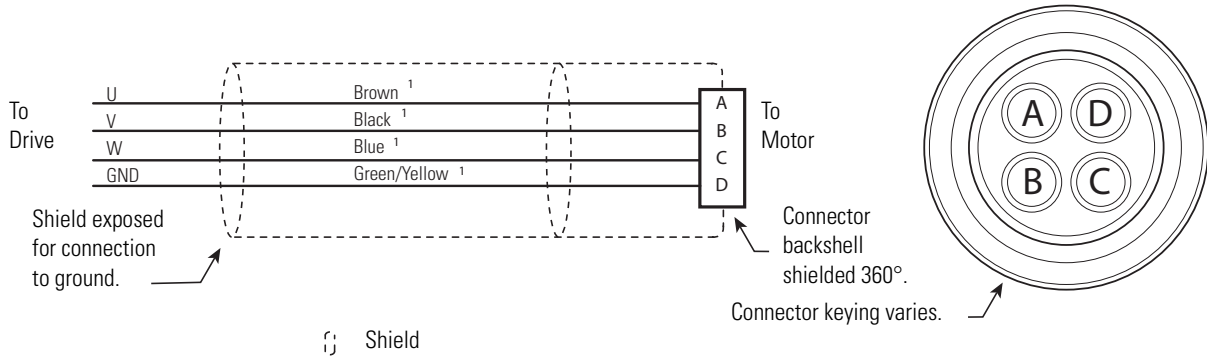

1 Power wire gauge (6, 8, 14, or 16 AWG) varies based on motor and power requirements. Refer to Kinetix Motion Control Selection Guide, publication GMC-SG001, for additional information.

**2090-XXNPMF-10Sxx**

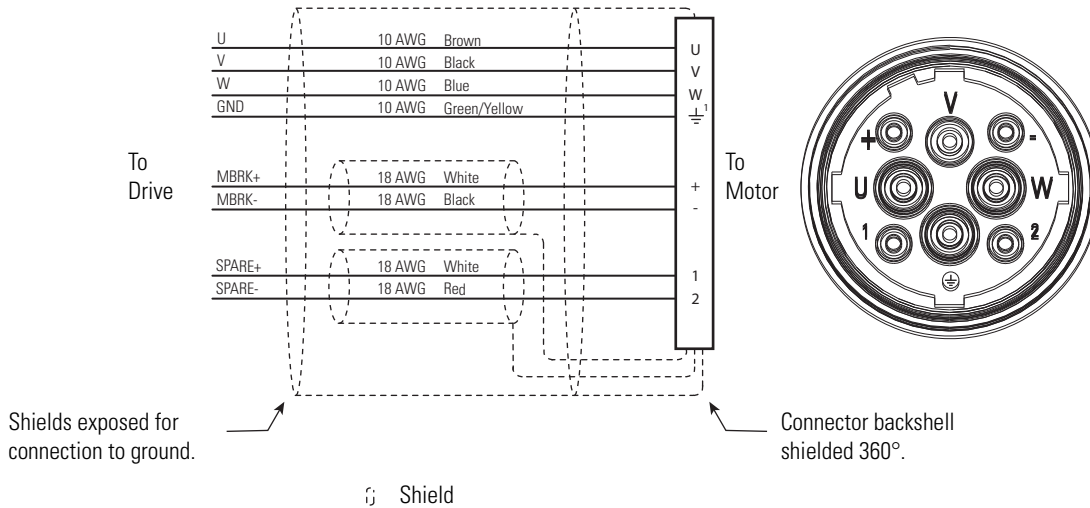

1 Contact  $\frac{\perp}{\perp}$  (GND) is connected to the backshell internal to the connector.

### 2090-XXNPMF-14S<sub>xx</sub>, 2090-XXNPMF-16S<sub>xx</sub>

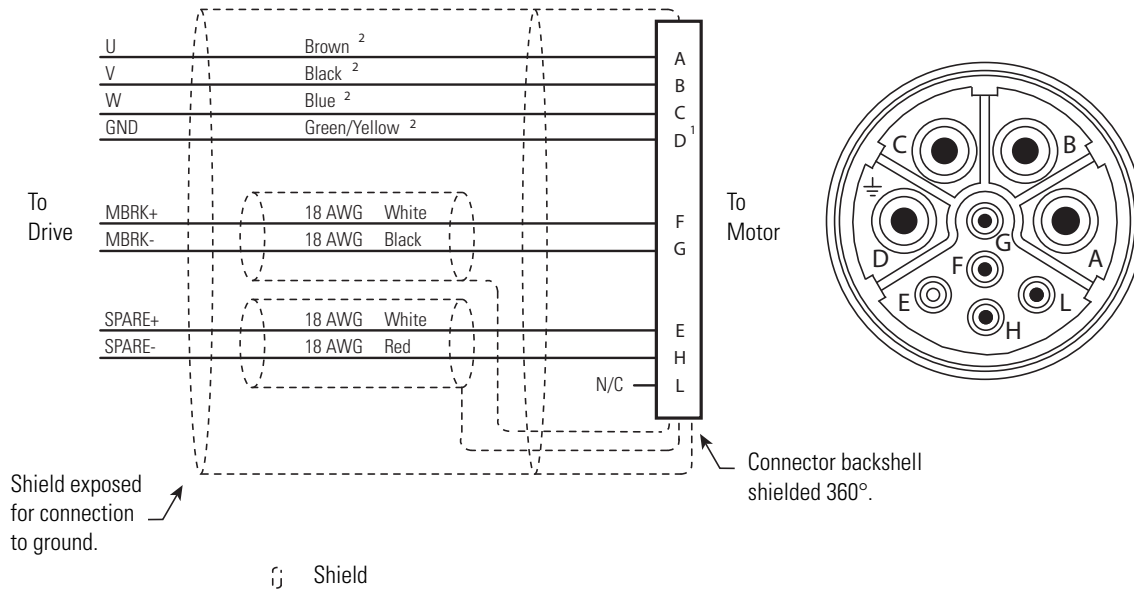

- 1 Contact D (GND) connection to the backshell is internal to the connector.
- 1 Power wire gauge (14 or 16 AWG) varies based on motor and power requirements. Refer to Kinetix Motion Control Selection Guide, publication GMC-SG001, for additional information.

### 2090-XXNPMP-10S<sub>xx</sub>, 2090-XXNPMP-14S<sub>xx</sub>, 2090-XXNPMP-16S<sub>xx</sub>

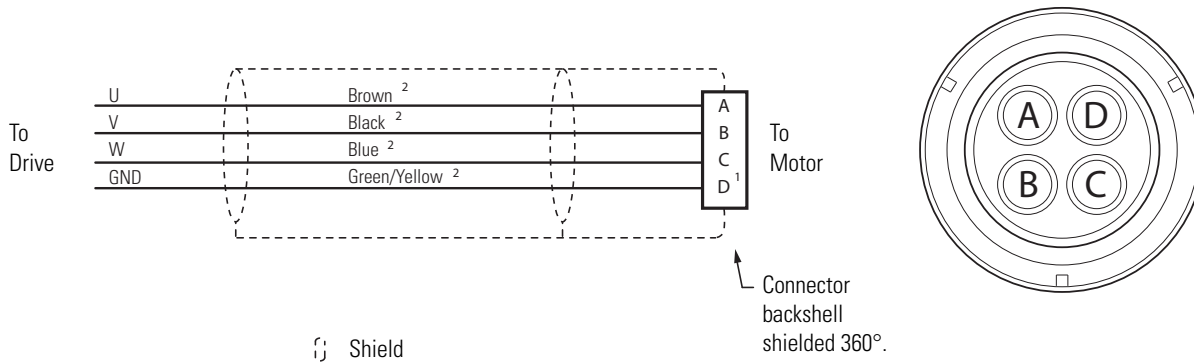

- 1 Contact D (GND) connection to the backshell is internal to the connector.
- 2 Power wire gauge (10, 14, or 16 AWG) varies based on motor and power requirements. Refer to Kinetix Motion Control Selection Guide, publication GMC-SG001, for additional information.

### 2090-XXNPN-16Sxx

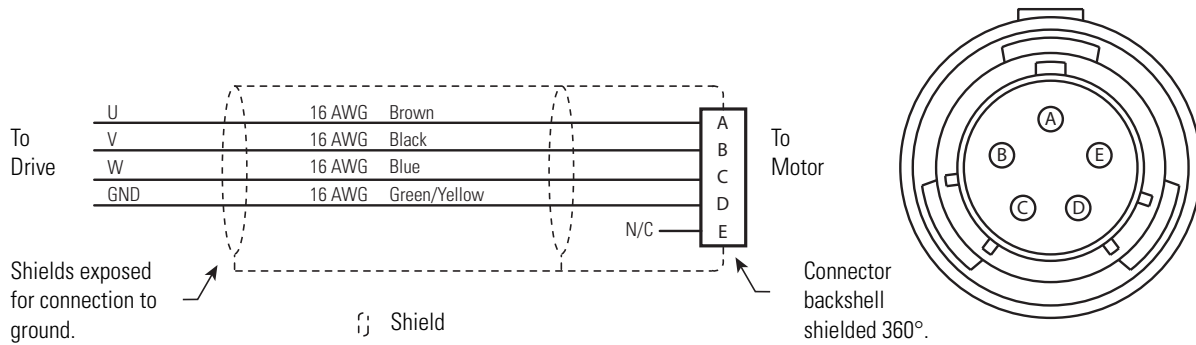

### 2090-XXNPT-16Sxx

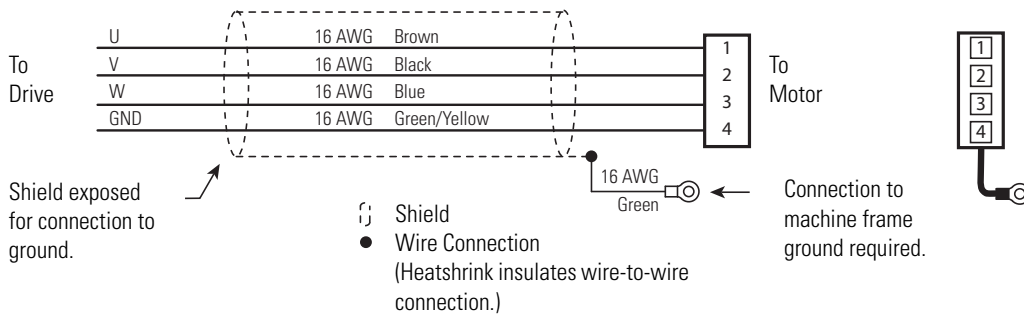

### 2090-XXNPY-16Sxx

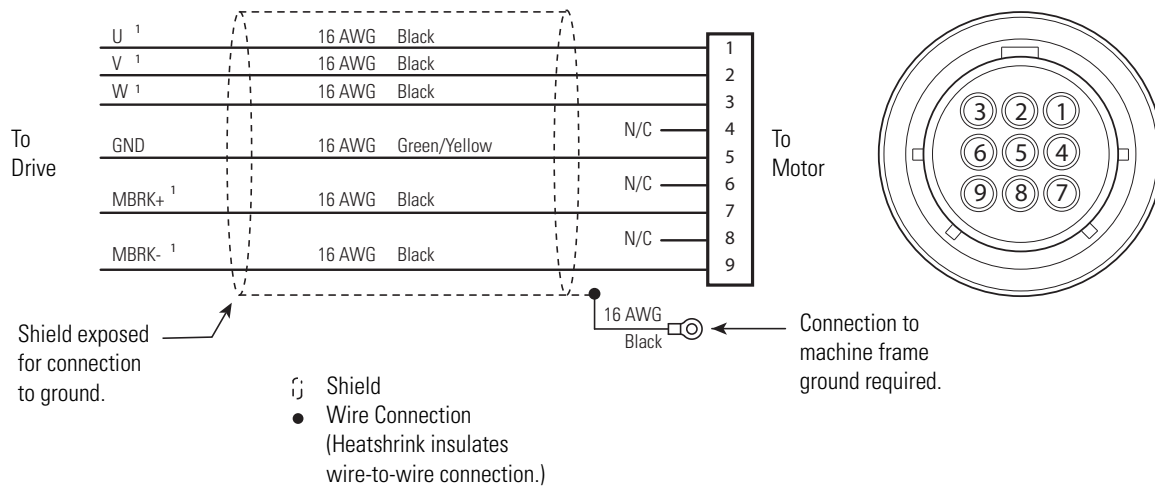

1 Each wire has its respective pin number printed on the wire insulation.

# Rockwell Automation Support

Rockwell Automation provides technical information on the Web to assist you in using its products. At <http://support.rockwellautomation.com>, you can find technical manuals, a knowledge base of FAQs, technical and application notes, sample code and links to software service packs, and a MySupport feature that you can customize to make the best use of these tools.

For an additional level of technical phone support for installation, configuration, and troubleshooting, we offer TechConnect support programs. For more information, contact your local distributor or Rockwell Automation representative, or visit <http://support.rockwellautomation.com>.

## Installation Assistance

If you experience a problem within the first 24 hours of installation, please review the information that's contained in this manual. You can also contact a special Customer Support number for initial help in getting your product up and running.

United States	1.440.646.3434 Monday – Friday, 8 a.m. – 5 p.m. EST
Outside United States	Please contact your local Rockwell Automation representative for any technical support issues.

## New Product Satisfaction Return

Rockwell Automation tests all of its products to ensure that they are fully operational when shipped from the manufacturing facility. However, if your product is not functioning and needs to be returned, follow these procedures.

United States	Contact your distributor. You must provide a Customer Support case number (call the phone number above to obtain one) to your distributor in order to complete the return process.
Outside United States	Please contact your local Rockwell Automation representative for the return procedure.

Allen-Bradley, Rockwell Automation, and TechConnect are trademarks of Rockwell Automation, Inc.

Trademarks not belonging to Rockwell Automation are property of their respective companies.

[www.rockwellautomation.com](http://www.rockwellautomation.com)

### Power, Control and Information Solutions Headquarters

Americas: Rockwell Automation, 1201 South Second Street, Milwaukee, WI 53204-2496 USA, Tel: (1) 414.382.2000, Fax: (1) 414.382.4444

Europe/Middle East/Africa: Rockwell Automation, Vorstlaan/Boulevard du Souverain 36, 1170 Brussels, Belgium, Tel: (32) 2 663 0600, Fax: (32) 2 663 0640

Asia Pacific: Rockwell Automation, Level 14, Core F, Cyberport 3, 100 Cyberport Road, Hong Kong, Tel: (852) 2887 4788, Fax: (852) 2508 1846

Publication 2090-PC001B-EN-P - June 2008

Supersedes Publication 2090-PC001A-EN-P - June 2008

PN-18471

Copyright © 2008 Rockwell Automation, Inc. All rights reserved. Printed in the U.S.A.