

## Kinetix VPF Food-Grade Servo Motors with 063...165 mm Frame Size

Catalog Numbers VPF-A0632, VPF-A0633, VPF-A0752, VPF-A0753, VPF-A1001, VPF-A1002, VPF-A1003, VPF-A1153, VPF-A1303, VPF-A1304, VPF-B0632, VPF-B0633, VPF-B0752, VPF-B0753, VPF-B1001, VPF-B1002, VPF-B1003, VPF-B1153, VPF-B1303, VPF-B1304, VPF-B1652

Topic	Page
Summary of Changes	1
About the Kinetix VPF Food-grade Motors	1
Catalog Number Explanation	2
Before You Install the Motor	2
Functional Safety	4
Motor Installation	5
Motor Dimensions (063 mm and 075 mm frame sizes)	7

Topic	Page
Motor Dimensions (100...165 mm frame sizes)	9
Connector Data	11
Load Force Ratings	11
Environmental Specifications	20
Motor Accessories	21
Additional Resources	22

### Summary of Changes

This publication contains the following new or updated information. This list includes substantive updates only and is not intended to reflect all changes. Translated versions are not always available for each revision.

Topic	Page
Updated speed, max for VPF motors: B0632F, B0633M, B0752E, and B0753F in the axial load force ratings tables.	12...20
Removed IP ratings. Replaced with a reference to <a href="#">KNX-TD001</a> .	20
Added compatibility to ArmorKinetix.	throughout
Updated document links, terms, and formats.	throughout

### About the Kinetix VPF Food-grade Motors

Kinetix® VPF food-grade motors feature single-turn or multi-turn high-resolution absolute encoders, and are available with or without 24V DC brakes. These compact brushless servo motors combine the characteristics of the Kinetix VPF low-inertia motors with unique features designed for food and beverage applications. The motors also have a corrosion-resistant stainless steel shaft and food-grade paint.

You are responsible for inspecting the equipment before accepting the shipment from the freight company. Check the items that you receive against your purchase order. Notify the carrier of shipping damage or missing items immediately. Store or operate your motor in a clean and dry location within the [Environmental Specifications on page 20](#).



**ATTENTION:** To avoid personal injury and damage to the motor, do not lift or handle the motor by the motor shaft. The cap on the shaft can come loose and cause you to drop the motor.

## Catalog Number Explanation

VP F - x xxx x x - x J 1 x A F

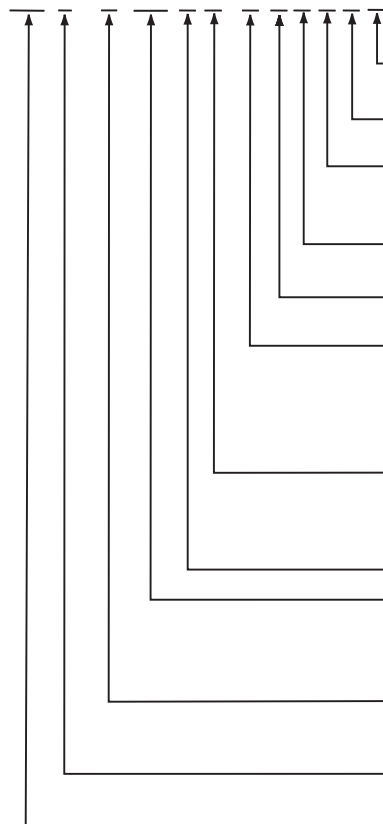

**Factory Options**

F= Food-grade shaft seal, Fluoroloy G4 (PTFE)

**Mounting Flange**

A = IEC metric, free mounting holes (type FF)

**Brake**

2 = No Brake  
4 = 24V DC Brake

**Connector**

1 = Single SpeedTec DIN connector, right angle, 315° rotatable

**Shaft Key**

J = Shaft key

**Feedback**

C = 18-bit absolute single-turn digital encoder (Hiperface DSL protocol)  
 P = 18-bit absolute multi-turn (4096 revolutions) digital encoder (Hiperface DSL protocol)  
 Q = 23-bit absolute multi-turn digital encoder (Hiperface DSL protocol) SIL2/PLD rated, 12-bit secondary safety channel<sup>(1)</sup>  
 W = 18-bit absolute multi-turn digital encoder (Hiperface DSL protocol) SIL2/PLD rated, 9-bit secondary safety channel<sup>(2)</sup>

**Rated Speed<sup>(3)</sup>**

A = 1500 rpm	D = 3000 rpm	M = 6000 rpm
B = 2000 rpm	E = 3500 rpm	T = 6750 rpm
C = 2500 rpm	F = 4500 rpm	U = 8000 rpm

**Magnet Stack Length (1, 2, 3, 4 stacks)<sup>(4)</sup>**

**Frame Size - Bolt Circle Diameter (BCD)**

063 = 63 mm	115 = 115 mm
075 = 75 mm	130 = 130 mm
100 = 100 mm	165 = 165 mm

**Voltage Class**

A = 200V  
B = 400V

**Series Type**

F = Food-grade enclosure (including food-grade shaft seal)

**Series**

VP = Permanent magnet rotary servo motors optimized to the ratings of Kinetix® 5500, Kinetix 5700, and ArmorKinetix® servo drives.

(1) This encoder option is available with only VPF-A/B100xx, VPF-A/B115xx, VPF-A/B130xx, and VPF-B165xx motor frame sizes.  
 (2) This encoder option is available with only VPF-B063xx and VPF-B075xx motor frame sizes.  
 (3) Rated speed hierarchy is only for comparative purposes. Use Motion Analyzer software to size and select motors for your application, and/or the torque/speed curves in the Kinetix 5500 Drive System Design Guide, publication [KNX-RM009](#) and the Kinetix 5700 Drive System Design Guide, publication [KNX-RM010](#).  
 (4) See [Motor Dimensions \(063 mm and 075 mm frame sizes\)](#) and [Motor Dimensions \(100...165 mm frame sizes\)](#) for dimensional changes (L, LB, LD, and LE) that result from the number of magnet stacks.

## Before You Install the Motor

Perform these inspection steps and review the guidelines for shaft seals, couplings and pulleys, and electrical noise prevention.

1. Remove the motor carefully from its shipping container.
2. Inspect the motor for any damage.
3. Examine the motor frame, front output shaft, and mounting pilot for any defects.
4. Notify the carrier of shipping damage immediately.



**ATTENTION:** Do not attempt to open and modify the motor beyond changing the connector orientation as described on [page 5](#). Only a qualified Rockwell Automation employee can service this motor.

## Remove the Shaft Cap

Remove the protective cap installed on the motor shaft with your hand or by prying it off with a screwdriver. Do not use a hammer or other tools as they can damage the motor shaft.

## Prolong Motor Life

Proper design and maintenance can increase the life of a servo motor. Follow these guidelines to maximize the life of a servo motor that is operated within the [Environmental Specifications](#):

- Create a drip loop in the single motor cable to carry liquids away from the connector.
- Whenever possible, provide shields that protect the motor housing, shaft, seals, and their junctions from contamination by foreign matter or fluids.
- Shaft seals are subject to wear and require periodic inspection and replacement. Replacement is recommended every 3 months, not to exceed 12 months, depending on use. See [Shaft Seal Kits on page 21](#) for more information.
- Inspect the motor and seals for damage or wear regularly. If you detect damage or excessive wear, replace the item.

## Shaft Seals

A shaft seal is required for Kinetix VPF food-grade motors. An IP66 or IP67 rating for the motor requires a shaft seal and Kinetix 2090 cables with environmentally sealed connectors.

See the following information on environmental ratings, shaft seals, and environmentally sealed connectors and cables compatible with the Kinetix VPF food-grade motors:

- See [Shaft Seal Kits on page 21](#) for seal kits compatible with your motor.
- See Kinetix Rotary Motion Specifications Technical Data, publication [KNX-TD001](#), for Kinetix 2090 cables with environmentally sealed connectors compatible with these motors.

## Couplings and Pulleys

Mechanical connections to the motor shaft, such as couplings and pulleys, require a torsionally rigid coupling or a reinforced timing belt. The high dynamic performance of servo motors can cause couplings, pulleys, or belts to loosen or slip over time. A loose or slipping connection causes system instability and can damage the motor shaft. All connections between the system and the servo motor shaft must be rigid to achieve acceptable response from the system. Periodically inspect connections to verify their rigidity.

When mounting couplings or pulleys to the motor shaft, verify that the connections are properly aligned and that axial and radial loads are within the specifications of the motor. See [Load Force Ratings on page 11](#) for guidelines to achieve 20,000 hours of motor bearing life.



**ATTENTION:** Damage can occur to the motor bearings and the feedback device if sharp impact is applied to the shaft during installation of couplings and pulleys. Damage to the feedback device can result from applying leverage to the motor mounting face when removing any devices mounted on the motor shaft. Do not strike the shaft, couplings, or pulleys with tools during installation or removal. Use a wheel puller to apply pressure from the user end of the shaft when removing any device from the motor shaft.

## Prevent Electrical Noise

Electromagnetic interference (EMI), commonly called electrical noise, can affect motor performance. Follow these guidelines to reduce the effects of EMI:

- Isolate the power transformers or install line filters on all AC input power lines.
- Use shielded cables.
- Shield signal cables from power wiring.
- Do not route motor cables over the vent openings on servo drives.
- Ground all equipment by using a single-point parallel ground system that employs ground bus-bars or large straps.
- If necessary, use additional electrical-noise reduction techniques to reduce EMI in noisy environments.

See System Design for Control of Electrical Noise Reference Manual, publication [GMC-RM001](#), for more information on reducing EMI.

## Install Cables

Proper cable routing and careful cable construction improves system electromagnetic compatibility (EMC).



**ATTENTION:** The overall shield on the single motor cable must be grounded to obtain an effective encoder signal. The encoder data signal is transmitted through an impedance-matched twisted-wire pair that requires effective shielding for optimum performance. Make sure that there is an effective connection between the cable shield and the drive system ground.

To install the single motor cable, observe these guidelines:

- Keep the cable length as short as possible.
- Ground the cable shield to prevent EMI from affecting other equipment.



**SHOCK HAZARD:** High voltage can be present on the shields of the single motor cable if the shields are not grounded. Verify that there is a connection to ground for all shields in the single motor cable.

## Functional Safety

Motors that are equipped with a Hiperface DSL® functional safety-rated feedback sensor are designed in compliance with the requirements of the following SICK STEGMANN GmbH documentation to maintain the functional safety rating of the feedback sensor attached. See [Catalog Number Explanation](#) for details about each option.

Motor Cat. No.	Feedback Sensor Functional-safety Reference Documentation (SICK STEGMANN GmbH)	
VPF-xxxxx-Q	HIPERFACE DSL Safety Manual, publication 8017596/YLRO	EFM50-2 Safe Motor Feedback Systems Operating Instructions, publication 8019321/2016-02-17
VPF-xxxxx-W		EKM36-2 Safe Motor Feedback Systems Operating Instructions, publication 8019481/2016-02-23

**IMPORTANT** In accordance with the feedback sensor manufacturer, you must mount a Hiperface DSL motor feedback system (used for a safety function) in an installation situation with a minimum protection class of IP54 according to standard IEC60529:1989 + A1:1999 + A2:2013.

## Certification

The TÜV Rheinland group has approved Kinetix VPF low-inertia servo motors equipped with functional-safety certified Hiperface DSL feedback sensors to enable a system to be capable of achieving a functional safety rating up to Performance Level d (PLd) and safety category 3 (CAT. 3) per EN ISO 13849, and SIL 2 per IEC 61508, EN 61800-5-2, and EN 62061 when used in conjunction with variable frequency drives that satisfy functional safety requirements of the Hiperface DSL Safety Manual (SICK STEGMANN GmbH, publication 8017596/YLRO).

To view the TÜV Rheinland certificate and other product certifications currently available from Rockwell Automation, go to [rok.auto/certifications](http://rok.auto/certifications).

## Important Safety Considerations

In addition to following the instructions throughout this document, you are responsible for the following:

- Complete a machine-level risk assessment.
- Certification of the machine to the desired EN ISO 13849 performance level or EN 62061 SIL level.
- Project management and proof testing in accordance with EN 61800-5-2.
- The safe-motor feedback system has a maximum Mission Time of 20 years. After this time, the feedback system must be taken out of service.
- The motor feedback system cannot support safety functions that are based on the absolute position without additional measures. In the case of safety functions that are based on the safe absolute position, the motor feedback system supplies only one channel without safety-related diagnostics upon powerup. You must implement a second channel by using other measures.
- The motor feedback system is not able to create a safe state for the drive system independently. The drive system creates the safe state as a response to an error displayed by the motor feedback system.
- To plan and use motors equipped with safety-rated feedback sensors requires technical skills that are not explained in this document.



**ATTENTION:** To avoid damage to the equipment, do not establish or remove electrical connections to the motor feedback system with the voltage switched on.

## Performance Level (PL) and Safety Integrity Level (SIL)

For safety-related control systems, Performance Level (PL), according to EN ISO 13849-1, and Safety Integrity Level (SIL) levels, according to IEC EN 61508 and EN 62061, include a rating of the system's ability to perform its safety functions. All of the safety related components of the control system must be included in a risk assessment and the determination of the achieved levels.

See the EN ISO 13849-1, IEC EN 61508, and EN 62061 standards for complete information on the requirements for PL and SIL determination.

## Safety Related Parameters

A motor that is equipped with a Hiperface DSL functional safety-rated feedback sensor is designed to maintain the functional safety rating of the feedback sensor attached. The safety parameters of the feedback sensors are as follows:

Attribute	Motor Cat. No.	
	VPF-xxxxx-WJ1xAF	VPF-xxxxx-QJ1xAF
SIL	SIL2 (IEC 61508), SIL CL2 (EN 62061)	
Probability of a Dangerous Failure per Hour (PFH)	4.0 E-08 1/h	3.80 E-08 1/h
Safety Category	CAT. 3 (EN ISO 13849)	
PL	PLd (EN ISO 13849)	

## Motor Installation

All motors include a mounting pilot for aligning the motor on a machine. To further protect the finish on the motor, it is recommended to insert the stainless steel washers that are included with Kinetix VPF motors. Motor installation must comply with all local regulations and use of equipment and installation practices that promote safety and electromagnetic compatibility. See the [Mounting Flange Washer Kits](#) for washer kit catalog numbers.

---

**IMPORTANT** Stainless steel washers inserted between the fastener head and motor flange are also recommended as a best mounting practice and are included with Kinetix VPF motors. It is recommended to insert stainless steel washers (smooth side on paint) between the fastener head and motor flange.

---



**ATTENTION:** Unmounted motors, disconnected mechanical couplings, loose shaft keys, and disconnected cables can be dangerous if power is applied. Identify (tag-out) disassembled equipment and restrict access to (lock-out) the electrical power. Before you apply power to the motor, remove the shaft key and other mechanical couplings that could be thrown from the shaft.

---



**ATTENTION:** Verify that cables are installed and restrained to prevent uneven tension or flexing at the connector. Provide support at 3 m (10 ft) intervals throughout the cable run. Excessive and uneven lateral force at the cable connector can result in the environmental seal opening and closing as the cable flexes.

---

## Change Connector Orientation

Kinetix VPF food-grade motors use a connector style that integrates the power, brake, and feedback signals within one connector. You can identify the connector style by the variable number in the motor catalog string. For example, in catalog number VPF-A1303F-CJ12AA, the **1** indicates a SpeedTec, right-angle, 315° rotatable connector (see [Catalog Number Explanation on page 2](#)).

The rotatable connector housing lets you move the connector into a position that best protects the connection from environmental contaminants and provides easy access.



**ATTENTION:** Connectors are designed to be rotated into a fixed position during motor installation and remain in that position without further adjustment. Strictly limit the applied forces and the number of times the connector is rotated to make sure that connectors meet the International Protection (IP) rating as outlined in [Environmental Specifications on page 20](#).

---



**ATTENTION:** Excessive force can damage the connector. Do not pull on the cable and do not use tools, such as pliers or locking pliers, to rotate the connector. Use your hands to rotate the connector.

---

Follow these steps to rotate a connector to a new position.

1. Mount and fully seat a mating cable on the motor connector.  
This step provides a larger area to grasp and extends the leverage force.
2. Grasp the mated connector and cable plug with your hands and slowly rotate the motor connector into the new position.
3. Remove the cable plug after the connector is aligned.

## Install the Motor

Perform these steps to install the motor.



**ATTENTION:** Damage can occur to the motor bearings and the feedback device if sharp impact is applied to the shaft during installation of couplings and pulleys. Damage to the feedback device can result from applying leverage to the motor mounting face when removing devices mounted on the motor shaft. Do not strike the shaft, couplings, or pulleys with tools during installation or removal. Use a wheel puller, to apply pressure from the user end of the shaft, when attempting to remove any device from the motor shaft.

---

1. Leave enough space around the motor so it can dissipate heat and stay within its specified operating temperature range. See [Environmental Specifications on page 20](#) for the operating temperature range.
- 

**IMPORTANT** Do not enclose the motor unless forced air is blown across the motor for cooling. A fan that blows air across the motor improves its performance. Keep other heat-producing devices away from the motor.

---

2. See [Load Force Ratings on page 11](#) to determine the maximum radial and axial shaft load ratings for your motor.
  3. Install the motor with the connector positioned beneath the motor housing.  
This position provides better environmental protection for the connector.
- 



**BURN HAZARD:** Outer surfaces of the motor can reach a high temperature, 125 °C (257 °F), during motor operation. Take precautions to prevent accidental contact with hot surfaces. Consider motor surface temperature when selecting the motor mating connections and cables.

---

4. Mount and align the motor.
5. Attach the single motor cable that transmits the power, feedback, and brake signals as described in the following steps.
  - a. Carefully align the cable connector with the motor connector.

The flat surface on the top of the motor connector and the flat surfaces on the cable connector must align for the cable connector to mate with the motor connector.



**ATTENTION:** Keyed connectors must be properly aligned and hand-tightened. Do not use tools, or apply excessive force, when mating the cable to the motor connector. If the connectors do not go together with light hand force, realign and try again.

---

- b. Hand-tighten the knurled collar one-quarter turn to fully seat the cable connector.



**ATTENTION:** The overall shield on the single motor cable must be grounded to obtain an effective encoder signal. The encoder data signal is transmitted through an impedance-matched twisted-wire pair that requires effective shielding for optimum performance. Be sure that there is an effective connection between the single-motor cable shield and the drive system ground.

---

- c. Form a drip loop in the cable to carry liquids away from the connectors.

# Motor Dimensions (063 mm and 075 mm frame sizes)

Dimensions are in mm (in.)

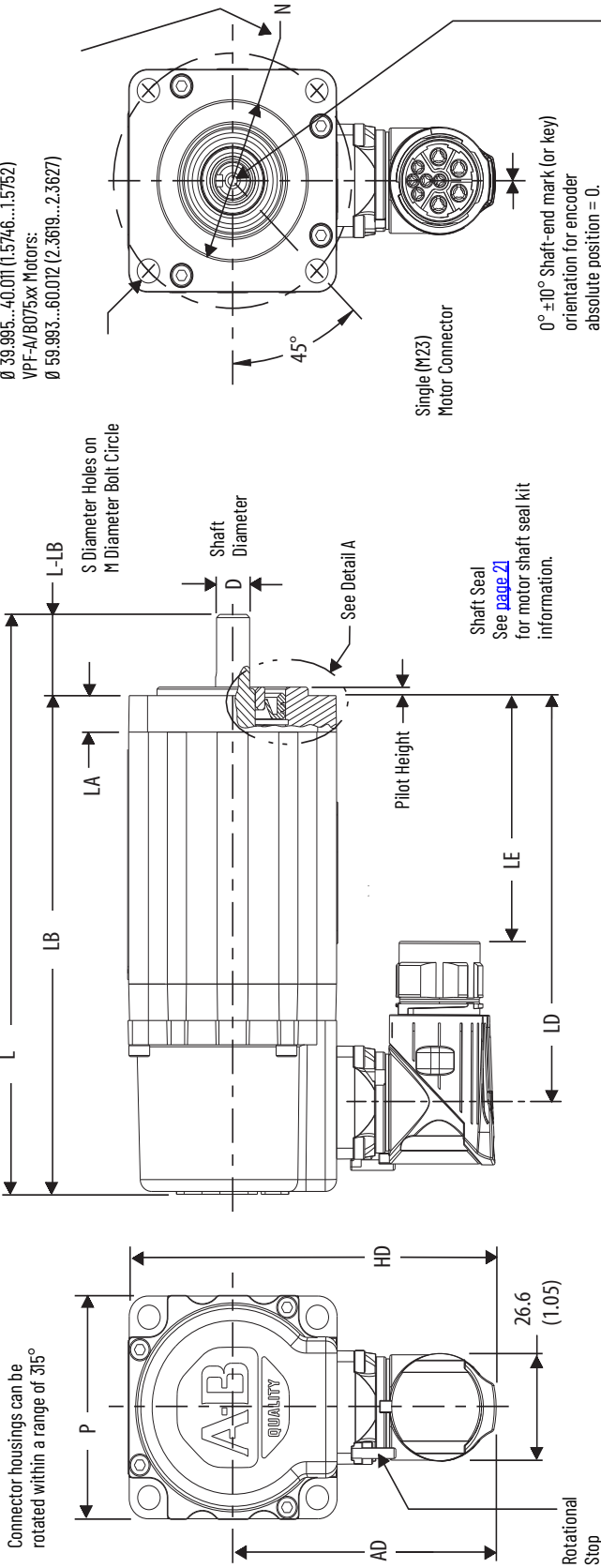

Pilot Diameter Tolerances  
 VPF-A/B063xx Motors:  
 $\varnothing\ 39.995\text{...}40.011\ (1.5746\text{...}1.5752)$   
 VPF-A/B075xx Motors:  
 $\varnothing\ 59.993\text{...}60.012\ (2.3619\text{...}2.3627)$

VPF-A/B075xx Motors:  
 Thread - M4 x 0.7-6H  
 Thread Depth - 10.0 (0.393)

Shaft End Threaded Hole  
 VPF-A/B063xx Motors:  
 Thread - M3 x 0.5-6H  
 Thread Depth - 9.0 (0.354)

Shaft Diameter Tolerances  
 VPF-A/B063xx Motors:  $\varnothing\ 8.998\text{...}9.007\ (0.3543\text{...}0.3546)$   
 VPF-A/B075xx Motors:  $\varnothing\ 10.997\text{...}11.008\ (0.4330\text{...}0.4334)$

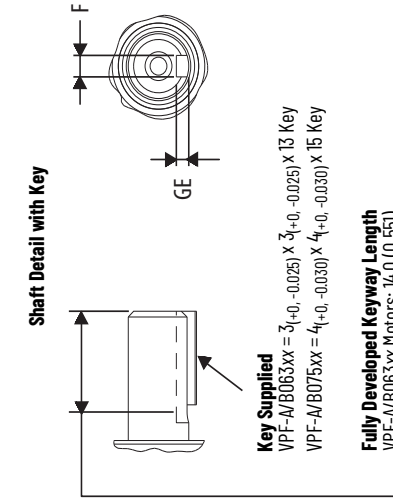

Shaft, Pilot, and Keyway Tolerances	VPF-A/B063xx	VPF-A/B075xx
Shaft Runout (T.I.R.) <sup>(1)</sup>	0.030 (0.0012)	0.035 (0.0014)
Pilot Eccentricity (T.I.R.)	0.08 (0.0031)	0.08 (0.0031)
Max Face Runout (T.I.R.)	0.08 (0.0031)	0.08 (0.0031)
Keyway Depth (GE)	1.80...1.90 (0.071...0.075)	2.50...2.60 (0.098...0.102)
Keyway Width (F)	2.97...2.996 (0.117...0.118)	3.970...4.000 (0.156...0.158)

(1) Total indicator runout (TIR).

**Motor Dimensions (063 mm and 075 mm frame sizes)**

Motor Cat. No.	AD mm (in.)	HD mm (in.)	LA mm (in.)	LD (1) mm (in.)	LE (1) mm (in.)	L (1) mm (in.)	LB (1) mm (in.)	L-LB (2) mm (in.)	D (3) mm (in.)	M mm (in.)	S (4) mm (in.)	N (3) mm (in.)	P mm (in.)	GE (3) mm (in.)	F (3) mm (in.)
VPF-AI/80632	69.5 (2.74)	97.0 (3.82)	9.0 (0.35)	125.2 (4.93)	85.3 (3.36)	168.1 (6.61)	148.1 (5.83)	20.0 (0.787)	9.0 (0.354)	63.0 (2.480)	5.80 (0.234)	40.0 (1.575)	55.0 (2.17)	1.90 (0.075)	3.0 (0.118)
				150.2 (5.91)	110.3 (4.34)	193.1 (7.59)	173.1 (6.81)								
VPF-AI/80752	77.0 (3.03)	112.0 (4.41)	9.0 (0.35)	127.0 (5.00)	87.1 (3.43)	172.9 (6.80)	149.9 (5.90)	23.0 (0.906)	11.0 (0.433)	75.0 (2.953)	5.80 (0.234)	60.0 (2.362)	70.0 (2.76)	2.60 (0.102)	4.0 (0.157)
				152.0 (5.98)	112.1 (4.41)	197.9 (7.79)	174.9 (6.89)								

(1) If ordering a VPF-AI/8063xx or VPF-AI/8075xx motor with brake, add 30.6 mm (1.20 in.) to dimension L, LB, LE, and LD.

(2) Tolerance for this dimension is ±0.7 mm (±0.028 in.).

(3) For keyway, shaft diameter, and pilot diameter tolerances, see the diagram or [Shaft, Pilot, and Keyway Tolerances](#) table above.

(4) Tolerance for this dimension is 0.3, -0.0 mm (±0.006 in.).

Motors are designed to metric dimensions. Inch dimensions are approximate conversions from millimeters. Dimensions without tolerances are for reference. Dimensions are for reference only and should not be used for manufacturing purposes.



# Motor Dimensions (100...165 mm frame sizes)

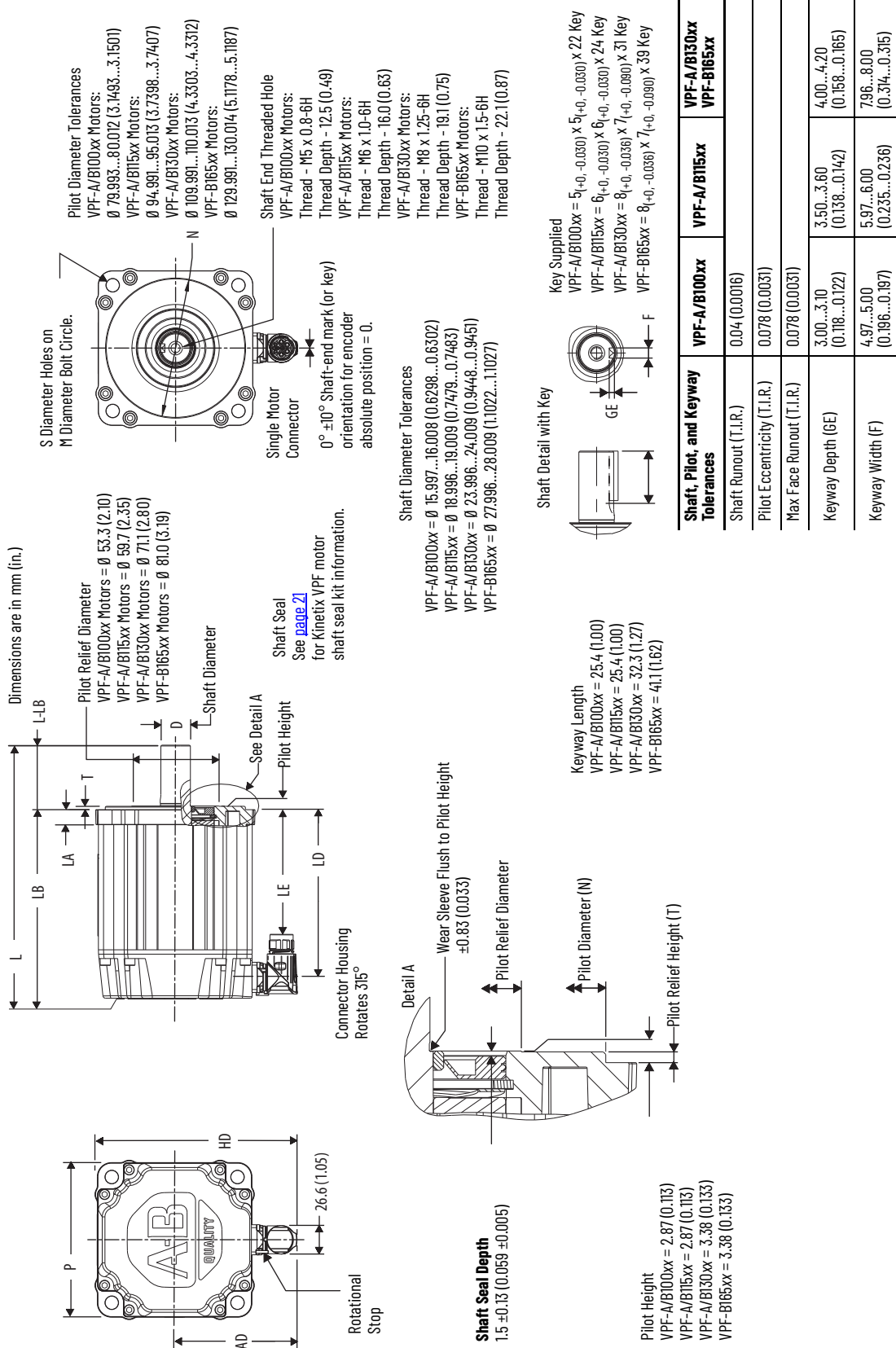

**Motor Dimensions (100...165 mm frame sizes)**

Motor Cat. No.	AD mm (in.)	HD mm (in.)	T mm (in.)	LA mm (in.)	LD (1) mm (in.)	LE (1) mm (in.)	L (1) mm (in.)	LB (1) mm (in.)	L-LB (2) mm (in.)	D (3) mm (in.)	H mm (in.)	S mm (in.)	N (3) mm (in.)	P mm (in.)	GE (3) mm (in.)	F (3) mm (in.)
VPF-A/B1001					108.7 (4.28)	88.9 (2.71)	189.8 (6.68)	129.8 (5.11)								
VPF-A/B1002	86.5 (3.40)	131.2 (5.17)	2.74 (0.108)	9.90 (0.39)	134.1 (5.28)	94.3 (3.71)	195.2 (7.68)	155.2 (6.11)	40.0 (1.575)	16.0 (0.630)	100.0 (3.937)	7.00 (4) (0.283)	80.0 (3.15)	89.4 (3.52)	3.0 (0.118)	5.0 (0.197)
VPF-A/B1003					159.5 (6.28)	119.7 (4.71)	220.6 (8.68)	180.6 (7.11)								
VPF-A/B1153	90.8 (3.58)	140.0 (5.51)	2.74 (0.108)	10.16 (0.40)	156.0 (6.14)	116.1 (4.57)	277.0 (8.54)	177.0 (6.97)	40.0 (1.575)	19.0 (0.748)	115.0 (4.528)	10.00 (4) (0.401)	95.0 (3.74)	98.3 (3.87)	3.5 (0.138)	6.0 (0.236)
VPF-A/B1303	99.6 (3.88)	155.4 (6.12)	2.74 (0.108)	12.19 (0.48)	159.3 (6.27)	119.4 (4.70)	230.3 (9.06)	180.3 (7.10)	50.0 (1.969)	24.0 (0.945)	130.0 (5.118)	10.00 (4) (0.401)	110.0 (4.331)	113.7 (4.48)	4.0 (0.158)	8.0 (0.315)
VPF-A/B1304					184.7 (7.27)	144.8 (5.70)	255.7 (10.06)	205.7 (8.10)								
VPF-B1652	113.3 (4.46)	185.0 (7.28)	3.12 (0.123)	14.0 (0.55)	206.2 (8.12)	166.4 (6.55)	286.4 (11.27)	226.4 (8.92)	60.0 (2.362)	28.0 (1.102)	165.0 (6.496)	12.00 (5) (0.481)	130.0 (5.118)	143.5 (5.65)	4.0 (0.158)	8.0 (0.315)

(1) If ordering a VPF-A/B100xx-xxx4xx motor with brake, add 34.5 mm (1.36 in.) to dimensions L, LB, LE, and LD.

If ordering a VPF-A/B115xx-xxx4xx motor with brake, add 48.5 mm (1.91 in.) to dimensions L, LB, LE, and LD.

If ordering a VPF-A/B130xx-xxx4xx motor with brake, add 48.5 mm (1.91 in.) to dimensions L, LB, LE, and LD.

If ordering a VPF-B165xx-xxx4xx motor with brake, add 51.5 mm (2.03 in.) to dimensions L, LB, LE, and LD.

(2) Tolerance for this dimension is ±0.7 mm (±0.028 in.).

(3) For keyway, shaft diameter, and pilot diameter tolerances, see the diagram or [Shaft, Pilot, and Keyway Tolerances](#) table on [page 9](#).

(4) Tolerance for this dimension is +0.36, -0.0 mm (±0.007 in.).

(5) Tolerance for this dimension is +0.43, -0.0 mm (±0.008 in.).

Motors are designed to metric dimensions. Inch dimensions are approximate conversions from millimeters. Dimensions without tolerances are for reference. Dimensions are for reference only and should not be used for manufacturing purposes.

## Connector Data

This section identifies the power, feedback, and brake pins on the motor connector.

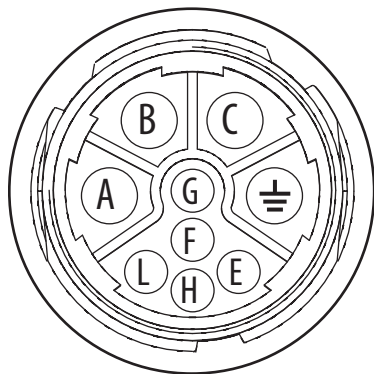

**M23 Motor Connector Pinouts**

Pin	High-resolution Encoder
A	Phase U
B	Phase V
C	Phase W
⊕	Ground
E	DATA+
F	MBRK+
G	MBRK-
H	DATA-
L	Reserved

## Load Force Ratings

Motors can operate with a sustained shaft load. The location and direction of radial and axial load forces are shown in the figure, and maximum load-rating values are in the tables.

### Load Forces on Shaft

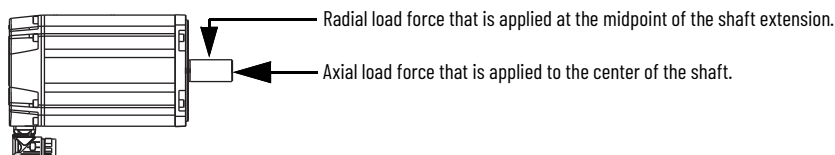

The following tables represent 20,000-hour  $L_{10}$  bearing fatigue life at various loads and speeds. This 20,000-hour bearing life does not account for possible application-specific life reduction, such as bearing grease contamination from external sources.

## Kinetix Food-grade Motors (063 mm and 075 mm frame size)

### Radial Load Force Ratings (maximum) for Non-brake Motors

Motor Cat. No. (1)	Speed, max rpm	rpm														
		500 kgf	1000 kgf	1500 kgf	2000 kgf	2500 kgf	3000 kgf	3500 kgf	4000 kgf	4500 kgf	5000 kgf	6000 kgf	6500 kgf	7000 kgf	7500 kgf	8000 kgf
VPF-A0632F	4800	-	28.9	25.2	-	-	21.0 *	-	-	-	17.1 *	-	-	-	-	-
VPF-A0633C	3000	38.1	30.3	27.4 *	-	-	21.0	-	-	-	-	-	-	-	-	-
VPF-A0633F	4500	38.1	-	26.4	-	-	21.0	-	-	18.3	-	-	-	-	-	-
VPF-A0752C	3300	36.1	28.6	25.9 *	-	-	-	19.2 *	-	-	-	-	-	-	-	-
VPF-A0752E	4800	36.1	28.6	-	-	21.8 *	-	-	-	-	17.0 *	-	-	-	-	-
VPF-A0753C	3300	37.8	30.0	27.5 *	-	-	-	20.2 *	-	-	-	-	-	-	-	-
VPF-A0753E	4600	37.8	30.0	-	-	23.3 *	-	-	-	-	18.0 *	-	-	-	-	-
VPF-B0632F	4600	-	28.9	25.2	-	-	21.0 *	-	-	-	17.1 *	-	-	-	-	-
VPF-B0632T	8000	-	-	-	22.9	-	-	-	18.2	-	-	-	15.6 *	-	-	14.4
VPF-B0633M	6700	-	30.3	-	24.0	-	-	-	19.2 *	-	-	-	-	15.9 *	-	-
VPF-B0633T	8000	-	-	26.4	-	-	21.0	-	-	-	-	16.8 *	-	-	-	15.1
VPF-B0752E	4900	36.1	28.6	-	-	22.0 *	-	-	-	-	17.0 *	-	-	-	-	-
VPF-B0752F	7000	-	28.6	-	22.7	-	-	19.3 *	-	-	-	-	-	15.0	-	-
VPF-B0752M	8000	-	-	25.0	-	-	20.8	-	-	-	16.8 *	-	-	-	-	14.3
VPF-B0753E	4500	37.8	30.0	-	23.8	-	-	-	-	18.2	-	-	-	-	-	-
VPF-B0753F	6600	-	30.0	-	23.8	-	-	20.6 *	-	-	-	-	16.1	-	-	-
VPF-B0753M	8000	-	-	26.2	-	-	19.8	-	-	-	18.0 *	-	-	-	-	15.0

(1) 1.0 kgf = 2.2 lbf or 9.8 N. An asterisk (\*) indicates a load rating that is measured at an rpm value that is less than the value listed for that column.

### Axial Load Force Ratings (maximum radial load) for Non-brake Motors

Motor Cat. No. (1)	Speed, max rpm	rpm														
		500 kgf	1000 kgf	1500 kgf	2000 kgf	2500 kgf	3000 kgf	3500 kgf	4000 kgf	4500 kgf	5000 kgf	6000 kgf	6500 kgf	7000 kgf	7500 kgf	8000 kgf
VPF-A0632F	4800	-	23.5	19.7	-	-	15.5 *	-	-	-	11.9 *	-	-	-	-	-
VPF-A0633C	3000	32.7	24.2	21.3 *	-	-	15.0	-	-	-	-	-	-	-	-	-
VPF-A0633F	4500	32.7	-	20.3	-	-	15.0	-	-	12.6	-	-	-	-	-	-
VPF-A0752C	3300	31.5	23.3	20.5 *	-	-	-	13.9 *	-	-	-	-	-	-	-	-
VPF-A0752E	4800	31.5	23.3	-	-	16.4 *	-	-	-	-	11.8 *	-	-	-	-	-
VPF-A0753C	3300	32.5	24.1	21.5 *	-	-	-	14.3 *	-	-	-	-	-	-	-	-
VPF-A0753E	4600	32.5	24.1	-	-	17.3 *	-	-	-	-	12.4 *	-	-	-	-	-
VPF-B0632F	4600	-	23.5	19.7	-	-	15.5 *	-	-	-	11.9 *	-	-	-	-	-
VPF-B0632T	8000	-	-	-	17.4	-	-	-	12.9	-	-	-	10.6	-	-	9.5
VPF-B0633M	6700	-	24.2	-	17.9	-	-	-	13.4 *	-	-	-	-	10.5 *	-	-
VPF-B0633T	8000	-	-	20.3	-	-	15.0	-	-	-	-	11.3 *	-	-	-	9.8
VPF-B0752E	4900	31.5	23.3	-	-	16.6 *	-	-	-	-	11.8 *	-	-	-	-	-
VPF-B0752F	7000	-	23.3	-	17.3	-	-	14.0 *	-	-	-	-	-	10.0	-	-
VPF-B0752M	8000	-	-	19.6	-	-	14.5	-	-	-	11.7 *	-	-	-	-	9.5
VPF-B0753E	4500	32.5	24.1	-	17.8	-	-	-	-	12.5	-	-	-	-	-	-
VPF-B0753F	6600	-	24.1	-	17.8	-	-	14.7 *	-	-	-	-	10.7	-	-	-
VPF-B0753M	8000	-	-	20.2	-	-	14.9	-	-	-	12.4 *	-	-	-	-	9.8

(1) 1.0 kgf = 2.2 lbf or 9.8 N. An asterisk (\*) indicates a load rating that is measured at an rpm value that is less than the value listed for that column.

**Axial Load Force Ratings (zero radial load) for Non-brake Motors**

Motor Cat. No. (1)	Speed, max rpm	rpm														
		500 kgf	1000 kgf	1500 kgf	2000 kgf	2500 kgf	3000 kgf	3500 kgf	4000 kgf	4500 kgf	5000 kgf	6000 kgf	6500 kgf	7000 kgf	7500 kgf	8000 kgf
VPF-A0632F	4800	-	27.5	23.0	-	-	18.1 *	-	-	-	13.9 *	-	-	-	-	-
VPF-A0633C	3000	37.1	27.5	24.1 *	-	-	17.1	-	-	-	-	-	-	-	-	-
VPF-A0633F	4500	37.1	-	23.0	-	-	17.1	-	-	14.3	-	-	-	-	-	-
VPF-A0752C	3300	37.1	27.5	24.1 *	-	-	-	16.4 *	-	-	-	-	-	-	-	-
VPF-A0752E	4800	37.1	27.5	-	-	19.3 *	-	-	-	-	13.9 *	-	-	-	-	-
VPF-A0753C	3300	37.1	27.5	24.5 *	-	-	-	16.4 *	-	-	-	-	-	-	-	-
VPF-A0753E	4600	37.1	27.5	-	-	19.7 *	-	-	-	-	14.2 *	-	-	-	-	-
VPF-B0632F	4600	-	27.5	23.0	-	-	18.1 *	-	-	-	13.9 *	-	-	-	-	-
VPF-B0632T	8000	-	-	-	20.3	-	-	-	15.1	-	-	-	12.4 *	-	-	11.1
VPF-B0633M	6700	-	27.5	-	20.3	-	-	-	15.2 *	-	-	-	-	11.9 *	-	-
VPF-B0633T	8000	-	-	23.0	-	-	17.1	-	-	-	-	12.8 *	-	-	-	11.1
VPF-B0752E	4900	37.1	27.5	-	-	19.5 *	-	-	-	-	13.9 *	-	-	-	-	-
VPF-B0752F	7000	-	27.5	-	20.3	-	-	-	16.5 *	-	-	-	-	-	11.8	-
VPF-B0752M	8000	-	-	23.0	-	-	17.1	-	-	-	13.8 *	-	-	-	-	11.1
VPF-B0753E	4500	37.1	27.5	-	20.3	-	-	-	-	14.3	-	-	-	-	-	-
VPF-B0753F	6600	-	27.5	-	20.3	-	-	-	16.8 *	-	-	-	-	12.2	-	-
VPF-B0753M	8000	-	-	23.0	-	-	17.1	-	-	-	14.2 *	-	-	-	-	11.1

(1) 1.0 kgf = 2.2 lbf or 9.8 N. An asterisk (\*) indicates a load rating that is measured at an rpm value that is less than the value listed for that column.

**Radial Load Force Ratings (maximum) for Brake Motors**

Motor Cat. No. (1)	Speed, max rpm	rpm														
		500 kgf	1000 kgf	1500 kgf	2000 kgf	2500 kgf	3000 kgf	3500 kgf	4000 kgf	4500 kgf	5000 kgf	6000 kgf	6500 kgf	7000 kgf	7500 kgf	8000 kgf
VPF-A0632F	4800	-	30.5	26.6	-	-	22.2 *	-	-	-	18.1 *	-	-	-	-	-
VPF-A0633C	3000	39.5	31.4	28.4 *	-	-	21.8	-	-	-	-	-	-	-	-	-
VPF-A0633F	4500	39.5	-	27.4	-	-	21.8	-	-	19.0	-	-	-	-	-	-
VPF-A0752C	3300	38.1	30.3	27.4	-	-	-	20.3 *	-	-	-	-	-	-	-	-
VPF-A0752E	4800	38.1	30.3	-	-	23.1 *	-	-	-	-	17.9 *	-	-	-	-	-
VPF-A0753C	3300	39.2	31.2	28.5 *	-	-	-	20.9 *	-	-	-	-	-	-	-	-
VPF-A0753E	4600	39.2	31.2	-	-	24.1 *	-	-	-	-	18.7 *	-	-	-	-	-
VPF-B0632F	4600	-	30.5	26.6	-	-	22.2 *	-	-	-	18.1 *	-	-	-	-	-
VPF-B0632T	8000	-	-	-	24.2	-	-	-	19.2	-	-	-	16.5 *	-	-	15.3
VPF-B0633M	6700	-	31.4	-	24.9	-	-	-	19.9 *	-	-	-	-	16.5 *	-	-
VPF-B0633T	8000	-	-	27.4	-	-	21.8	-	-	-	-	17.5 *	-	-	-	15.7
VPF-B0752E	4900	38.1	30.3	-	-	23.3 *	-	-	-	-	17.9 *	-	-	-	-	-
VPF-B0752F	7000	-	30.3	-	24.0	-	-	-	20.4 *	-	-	-	-	-	15.8	-
VPF-B0752M	8000	-	-	26.4	-	-	21.0	-	-	-	17.8 *	-	-	-	-	15.1
VPF-B0753E	4500	39.2	31.2	-	24.7	-	-	-	-	18.9	-	-	-	-	-	-
VPF-B0753F	6600	-	31.2	-	24.7	-	-	-	21.4 *	-	-	-	-	16.7	-	-
VPF-B0753M	8000	-	-	27.2	-	-	21.6	-	-	-	18.7 *	-	-	-	-	15.6

(1) 1.0 kgf = 2.2 lbf or 9.8 N. An asterisk (\*) indicates a load rating that is measured at an rpm value that is less than the value listed for that column.

**Axial Load Force Ratings (maximum radial load) for Brake Motors**

Motor Cat. No. (1)	Speed, max rpm	rpm														
		500 kgf	1000 kgf	1500 kgf	2000 kgf	2500 kgf	3000 kgf	3500 kgf	4000 kgf	4500 kgf	5000 kgf	6000 kgf	6500 kgf	7000 kgf	7500 kgf	8000 kgf
VPF-A0632F	4800	-	24.3	20.4	-	-	16.1 *	-	-	-	12.3 *	-	-	-	-	-
VPF-A0633C	3000	33.5	24.8	21.8 *	-	-	15.4	-	-	-	-	-	-	-	-	-
VPF-A0633F	4500	33.5	-	20.8	-	-	15.4	-	-	12.9	-	-	-	-	-	-
VPF-A0752C	3300	32.7	24.2	21.3 *	-	-	-	14.4 *	-	-	-	-	-	-	-	-
VPF-A0752E	4800	32.7	24.2	-	-	17.0 *	-	-	-	-	12.3 *	-	-	-	-	-
VPF-A0753C	3300	33.4	24.7	22.0 *	-	-	-	14.7 *	-	-	-	-	-	-	-	-
VPF-A0753E	4600	33.4	24.7	-	-	17.7 *	-	-	-	-	12.7 *	-	-	-	-	-
VPF-B0632F	4600	-	24.3	20.4	-	-	16.1 *	-	-	-	12.3 *	-	-	-	-	-
VPF-B0632T	8000	-	-	-	18.0	-	-	-	13.3	-	-	-	11.0 *	-	-	9.9
VPF-B0633M	6700	-	24.8	-	18.4	-	-	-	13.7 *	-	-	-	-	10.7 *	-	-
VPF-B0633T	8000	-	-	20.8	-	-	15.4	-	-	-	-	11.6 *	-	-	-	10.1
VPF-B0752E	4900	32.7	24.2	-	-	17.2 *	-	-	-	-	12.3 *	-	-	-	-	-
VPF-B0752F	7000	-	24.2	-	17.9	-	-	14.5 *	-	-	-	-	-	10.4	-	-
VPF-B0752M	8000	-	-	20.3	-	-	15.0	-	-	-	12.1 *	-	-	-	-	9.8
VPF-B0753E	4500	33.4	24.7	-	18.3	-	-	-	-	12.9	-	-	-	-	-	-
VPF-B0753F	6600	-	24.7	-	18.3	-	-	15.1 *	-	-	-	-	11.0	-	-	-
VPF-B0753M	8000	-	-	20.7	-	-	15.3	-	-	-	12.7 *	-	-	-	-	10.0

(1) 1.0 kgf = 2.2 lbf or 9.8 N. An asterisk (\*) indicates a load rating that is measured at an rpm value that is less than the value listed for that column.

**Axial Load Force Ratings (zero radial load) for Brake Motors**

Motor Cat. No. (1)	Speed, max rpm	rpm														
		500 kgf	1000 kgf	1500 kgf	2000 kgf	2500 kgf	3000 kgf	3500 kgf	4000 kgf	4500 kgf	5000 kgf	6000 kgf	6500 kgf	7000 kgf	7500 kgf	8000 kgf
VPF-A0632F	4800	-	27.5	23.0	-	-	18.1 *	-	-	-	13.9 *	-	-	-	-	-
VPF-A0633C	3000	37.1	27.5	24.1 *	-	-	17.1	-	-	-	-	-	-	-	-	-
VPF-A0633F	4500	37.1	-	23.0	-	-	17.1	-	-	14.3	-	-	-	-	-	-
VPF-A0752C	3300	37.1	27.5	24.1 *	-	-	-	16.4 *	-	-	-	-	-	-	-	-
VPF-A0752E	4800	37.1	27.5	-	-	19.3 *	-	-	-	-	13.9 *	-	-	-	-	-
VPF-A0753C	3300	37.1	27.5	24.5 *	-	-	-	16.4 *	-	-	-	-	-	-	-	-
VPF-A0753E	4600	37.1	27.5	-	-	19.7 *	-	-	-	-	14.2 *	-	-	-	-	-
VPF-B0632F	4600	-	27.5	23.0	-	-	18.1 *	-	-	-	13.9 *	-	-	-	-	-
VPF-B0632T	8000	-	-	-	20.3	-	-	-	15.1	-	-	-	12.4 *	-	-	11.1
VPF-B0633M	6700	-	27.5	-	20.3	-	-	-	15.2 *	-	-	-	-	11.9 *	-	-
VPF-B0633T	8000	-	-	23.0	-	-	17.1	-	-	-	-	12.8 *	-	-	-	11.1
VPF-B0752E	4900	37.1	27.5	-	-	19.5 *	-	-	-	-	13.9 *	-	-	-	-	-
VPF-B0752F	7000	-	27.5	-	20.3	-	-	16.5 *	-	-	-	-	-	11.8	-	-
VPF-B0752M	8000	-	-	23.0	-	-	17.1	-	-	-	13.8 *	-	-	-	-	11.1
VPF-B0753E	4500	37.1	27.5	-	20.3	-	-	-	-	14.3	-	-	-	-	-	-
VPF-B0753F	6600	-	27.5	-	20.3	-	-	16.8 *	-	-	-	-	12.2	-	-	-
VPF-B0753M	8000	-	-	23.0	-	-	17.1	-	-	-	14.2 *	-	-	-	-	11.1

(1) 1.0 kgf = 2.2 lbf or 9.8 N. An asterisk (\*) indicates a load rating that is measured at an rpm value that is less than the value listed for that column.

## Kinetix VPF Food-grade Motors (100...165 mm frame sizes)

### Radial Load Force Ratings (maximum) for Non-brake Motors

Motor Cat. No. (1)	Speed, max rpm	rpm														
		500 kgf	750 kgf	1000 kgf	1500 kgf	2000 kgf	2500 kgf	3000 kgf	3500 kgf	4000 kgf	4500 kgf	5000 kgf	5500 kgf	6000 kgf	6500 kgf	7000 kgf
VPF-A1001C	2800	79.1	-	62.8	-	49.8	-	44.6 *	-	-	-	-	-	-	-	-
VPF-A1001M	6500	-	-	-	54.9	-	46.3	-	-	-	38.0	-	-	-	33.6	-
VPF-A1002C	3000	87.9	-	69.7	-	55.4	-	48.4	-	-	-	-	-	-	-	-
VPF-A1002F	5000	-	-	69.7	60.9	-	-	48.4	-	-	-	40.8	-	-	-	-
VPF-A1003C	2250	93.6	-	74.3	64.9	-	56.7 *	-	-	-	-	-	-	-	-	-
VPF-A1003E	3750	93.6	-	74.3	-	59.0	-	-	-	47.8 *	-	-	-	-	-	-
VPF-A1003F	5500	-	-	-	64.9	-	54.8	-	-	46.8	-	-	42.1	-	-	-
VPF-A1153C	2300	106.4	-	84.5	73.8	-	64.0 *	-	-	-	-	-	-	-	-	-
VPF-A1303B	1950	132.9	-	105.5	92.2	84.4 *	-	-	-	-	-	-	-	-	-	-
VPF-A1303F	4000	-	-	105.5	-	83.7	-	73.1	-	66.5	-	-	-	-	-	-
VPF-A1304A	1600	140.2	122.5	112.2 *	-	95.2 *	-	-	-	-	-	-	-	-	-	-
VPF-A1304D	3000	140.2	-	111.3	-	88.3	-	77.2	-	-	-	-	-	-	-	-
VPF-B1001M	6000	-	-	-	-	49.8	-	43.5	-	39.6	-	-	-	34.6	-	-
VPF-B1002E	3300	87.9	-	69.7	-	55.4	-	-	46.8 *	-	-	-	-	-	-	-
VPF-B1002M	6000	-	-	-	60.9	-	-	48.4	-	-	42.2	-	-	38.4	-	-
VPF-B1003C	2500	93.6	-	74.3	64.9	-	54.8	-	-	-	-	-	-	-	-	-
VPF-B1003F	4750	-	-	74.3	64.9	-	-	51.5	-	-	-	44.2 *	-	-	-	-
VPF-B1003T	7000	-	-	-	64.9	-	54.8	-	-	-	45.0	-	-	-	-	38.9
VPF-B1153E	3200	106.4	-	84.5	-	67.0	-	-	57.3 *	-	-	-	-	-	-	-
VPF-B1153F	5000	-	-	84.5	-	67.0	-	58.6	-	-	-	49.4	-	-	-	-
VPF-B1303C	2250	132.9	-	105.5	92.2	-	80.5 *	-	-	-	-	-	-	-	-	-
VPF-B1303F	4000	-	-	105.5	-	83.7	-	74.0 *	-	66.5	-	-	-	-	-	-
VPF-B1304C	2150	140.2	-	111.3	99.5 *	-	86.2 *	-	-	-	-	-	-	-	-	-
VPF-B1304E	3500	-	-	111.3	97.2	-	84.3 *	-	73.3	-	-	-	-	-	-	-
VPF-B1652C	2700	180.7	-	143.4	125.3	-	-	103.0 *	-	-	-	-	-	-	-	-

(1) 1.0 kgf = 2.2 lbf or 9.8 N. An asterisk (\*) indicates a load rating that is measured at an rpm value that is less than the value listed for that column.

**Axial Load Force Ratings (maximum radial load) for Non-brake Motors**

Motor Cat. No. (1)	Speed, max rpm	rpm														
		500 kgf	750 kgf	1000 kgf	1500 kgf	2000 kgf	2500 kgf	3000 kgf	3500 kgf	4000 kgf	4500 kgf	5000 kgf	5500 kgf	6000 kgf	6500 kgf	7000 kgf
VPF-A1001C	2800	25.0	-	19.0	-	10.0	-	10.0 *	-	-	-	-	-	-	-	-
VPF-A1001M	6500	-	-	-	15.0	-	12.0	-	-	-	9.0	-	-	-	8.0	-
VPF-A1002C	3000	30.0	-	22.0	-	16.0	-	13.0	-	-	-	-	-	-	-	-
VPF-A1002F	5000	-	-	22.0	18.0	-	-	13.0	-	-	-	11.0	-	-	-	-
VPF-A1003C	2250	33.0	-	24.0	20.0	-	17.0 *	-	-	-	-	-	-	-	-	-
VPF-A1003E	3750	33.0	-	24.0	-	18.0	-	-	-	13.0 *	-	-	-	-	-	-
VPF-A1003F	5500	-	-	-	20.0	-	16.0	-	-	13.0	-	-	11.0	-	-	-
VPF-A1153C	2300	48.0	-	35.0	29.0	-	24.0 *	-	-	-	-	-	-	-	-	-
VPF-A1303B	1950	39.0	-	29.0	24.0	22.0 *	-	-	-	-	-	-	-	-	-	-
VPF-A1303F	4000	-	-	29.0	-	21.0	-	18.0	-	16.0	-	-	-	-	-	-
VPF-A1304A	1600	43.0	36.0	32.0 *	-	26.0 *	-	-	-	-	-	-	-	-	-	-
VPF-A1304D	3000	43.0	-	32.0	-	23.0	-	20.0	-	-	-	-	-	-	-	-
VPF-B1001M	6000	-	-	-	-	14.0	-	11.0	-	10.0	-	-	-	8.0	-	-
VPF-B1002E	3300	30.0	-	22.0	-	16.0	-	-	13.0 *	-	-	-	-	-	-	-
VPF-B1002M	6000	-	-	-	18.0	-	-	13.0	-	-	11.0	-	-	10.0	-	-
VPF-B1003C	2500	33.0	-	24.0	20.0	-	16.0	-	-	-	-	-	-	-	-	-
VPF-B1003F	4750	-	-	24.0	20.0	-	-	15.0	-	-	-	12.0 *	-	-	-	-
VPF-B1003T	7000	-	-	-	20.0	-	16.0	-	-	-	12.0	-	-	-	-	10.0
VPF-B1153E	3200	48.0	-	35.0	-	26.0	-	-	21.0 *	-	-	-	-	-	-	-
VPF-B1153F	5000	-	-	35.0	-	26.0	-	22.0	-	-	-	17.0	-	-	-	-
VPF-B1303C	2250	39.0	-	29.0	-	24.0	20.0 *	-	-	-	-	-	-	-	-	-
VPF-B1303F	4000	-	-	29.0	-	21.0	-	18.0 *	-	16.0	-	-	-	-	-	-
VPF-B1304C	2150	43.0	-	32.0	27.0 *	-	23.0 *	-	-	-	-	-	-	-	-	-
VPF-B1304E	3500	-	-	32.0	27.0	-	22.0 *	-	18.0	-	-	-	-	-	-	-
VPF-B1652C	2700	58.0	-	43.0	36.0	-	-	27.0 *	-	-	-	-	-	-	-	-

(1) 1.0 kgf = 2.2 lbf or 9.8 N. An asterisk (\*) indicates a load rating that is measured at an rpm value that is less than the value listed for that column.



**Axial Load Force Ratings (zero radial load) for Non-brake Motors**

Motor Cat. No. (1)	Speed, max rpm	rpm														
		500 kgf	750 kgf	1000 kgf	1500 kgf	2000 kgf	2500 kgf	3000 kgf	3500 kgf	4000 kgf	4500 kgf	5000 kgf	5500 kgf	6000 kgf	6500 kgf	7000 kgf
VPF-A1001C	2800	49.4	-	36.5	-	27.0	-	23.4 *	-	-	-	-	-	-	-	-
VPF-A1001M	6500	-	-	-	30.6	-	24.5	-	-	-	19.0	-	-	-	16.2	-
VPF-A1002C	3000	49.4	-	36.5	-	27.0	-	22.7	-	-	-	-	-	-	-	-
VPF-A1002F	5000	-	-	36.5	30.6	-	-	22.7	-	-	-	18.2	-	-	-	-
VPF-A1003C	2250	49.4	-	36.5	30.6	-	25.7 *	-	-	-	-	-	-	-	-	-
VPF-A1003E	3750	49.4	-	36.5	-	27.0	-	-	-	20.6 *	-	-	-	-	-	-
VPF-A1003F	5500	-	-	-	30.6	-	24.5	-	-	20.0	-	-	17.4	-	-	-
VPF-A1153C	2300	68.3	-	50.5	42.4	-	35.2 *	-	-	-	-	-	-	-	-	-
VPF-A1303B	1950	68.3	-	50.5	42.4	37.8 *	-	-	-	-	-	-	-	-	-	-
VPF-A1303F	4000	-	-	50.5	-	37.4	-	31.4	-	27.7	-	-	-	-	-	-
VPF-A1304A	1600	68.3	57.2	51.1 *	-	41.2 *	-	-	-	-	-	-	-	-	-	-
VPF-A1304D	3000	68.3	-	50.5	-	37.4	-	31.4	-	-	-	-	-	-	-	-
VPF-B1001M	6000	-	-	-	-	27.0	-	22.7	-	20.0	-	-	-	16.8	-	-
VPF-B1002E	3300	49.4	-	36.5	-	27.0	-	-	21.8 *	-	-	-	-	-	-	-
VPF-B1002M	6000	-	-	-	30.6	-	-	22.7	-	-	19.0	-	-	16.8	-	-
VPF-B1003C	2500	49.4	-	36.5	30.6	-	24.5	-	-	-	-	-	-	-	-	-
VPF-B1003F	4750	-	-	36.5	30.6	-	-	22.7	-	-	-	18.6 *	-	-	-	-
VPF-B1003T	7000	-	-	-	30.6	-	24.5	-	-	-	19.0	-	-	-	-	15.7
VPF-B1153E	3200	68.3	-	50.5	-	37.4	-	-	30.5 *	-	-	-	-	-	-	-
VPF-B1153F	5000	-	-	50.5	-	37.4	-	31.4	-	-	-	25.1	-	-	-	-
VPF-B1303C	2250	68.3	-	50.5	42.3	-	35.5 *	-	-	-	-	-	-	-	-	-
VPF-B1303F	4000	-	-	50.5	-	37.4	-	31.8 *	-	27.7	-	-	-	-	-	-
VPF-B1304C	2150	68.3	-	50.5	43.6 *	-	36.2 *	-	-	-	-	-	-	-	-	-
VPF-B1304E	3500	-	-	50.5	42.4	-	35.2 *	-	29.3	-	-	-	-	-	-	-
VPF-B1652C	2700	90.1	-	66.7	55.9	-	-	43.3 *	-	-	-	-	-	-	-	-

(1) 1.0 kgf = 2.2 lbf or 9.8 N. An asterisk (\*) indicates a load rating that is measured at an rpm value that is less than the value listed for that column.

Radial Load Force Ratings (maximum) for Brake Motors

Motor Cat. No. (1)	Speed, max rpm	rpm														
		500 kgf	750 kgf	1000 kgf	1500 kgf	2000 kgf	2500 kgf	3000 kgf	3500 kgf	4000 kgf	4500 kgf	5000 kgf	5500 kgf	6000 kgf	6500 kgf	7000 kgf
VPF-A1001C	2800	90.2	-	71.6	-	56.8	-	50.8 *	-	-	-	-	-	-	-	-
VPF-A1001M	6500	-	-	-	62.5	-	52.7	-	-	-	43.4	-	-	-	38.4	-
VPF-A1002C	3000	95.3	-	75.6	-	60.0	-	52.4	-	-	-	-	-	-	-	-
VPF-A1002F	5000	-	-	75.6	66.1	-	-	52.4	-	-	-	44.2	-	-	-	-
VPF-A1003C	2250	99.0	-	78.5	68.6	-	59.9 *	-	-	-	-	-	-	-	-	-
VPF-A1003E	3750	99.0	-	78.5	-	62.3	-	-	-	50.6 *	-	-	-	-	-	-
VPF-A1003F	5500	-	-	-	68.6	-	57.9	-	-	49.5	-	-	44.5	-	-	-
VPF-A1153C	2300	115.4	-	91.6	80.0	-	69.4 *	-	-	-	-	-	-	-	-	-
VPF-A1303B	1950	145.3	-	115.3	100.7	92.3 *	-	-	-	-	-	-	-	-	-	-
VPF-A1303F	4000	-	-	115.3	-	91.5	-	80.0	-	72.7	-	-	-	-	-	-
VPF-A1304A	1600	149.7	130.8	119.8 *	-	101.6 *	-	-	-	-	-	-	-	-	-	-
VPF-A1304D	3000	149.5	-	118.6	-	94.2	-	82.3	-	-	-	-	-	-	-	-
VPF-B1001M	6000	-	-	-	-	56.8	-	49.6	-	45.1	-	-	-	39.4	-	-
VPF-B1002E	3300	95.3	-	75.6	-	60.0	-	-	50.8 *	-	-	-	-	-	-	-
VPF-B1002M	6000	-	-	-	66.1	-	-	52.4	-	-	45.8	-	-	41.6	-	-
VPF-B1003C	2500	99.0	-	78.5	68.6	-	57.9	-	-	-	-	-	-	-	-	-
VPF-B1003F	4750	-	-	78.5	68.6	-	-	54.5	-	-	-	46.7 *	-	-	-	-
VPF-B1003T	7000	-	-	-	68.6	-	57.9	-	-	-	47.6	-	-	-	-	41.1
VPF-B1153E	3200	115.4	-	91.6	-	72.7	-	-	62.2 *	-	-	-	-	-	-	-
VPF-B1153F	5000	-	-	91.6	-	72.7	-	63.5	-	-	-	53.6	-	-	-	-
VPF-B1303C	2250	145.3	-	115.3	100.7	-	88.0 *	-	-	-	-	-	-	-	-	-
VPF-B1303F	4000	-	-	115.3	-	91.5	-	80.9 *	-	72.7	-	-	-	-	-	-
VPF-B1304C	2150	149.7	-	118.8	106.2 *	-	92.0 *	-	-	-	-	-	-	-	-	-
VPF-B1304E	3500	-	-	118.8	103.8	-	90.0 *	-	78.2	-	-	-	-	-	-	-
VPF-B1652C	2700	192.5	-	152.8	133.5	-	-	109.7 *	-	-	-	-	-	-	-	-

(1) 1.0 kgf = 2.2 lbf or 9.8 N. An asterisk (\*) indicates a load rating that is measured at an rpm value that is less than the value listed for that column.

## Axial Load Force Ratings (maximum radial load) for Brake Motors

Motor Cat. No. (1)	Speed, max rpm	rpm														
		500 kgf	750 kgf	1000 kgf	1500 kgf	2000 kgf	2500 kgf	3000 kgf	3500 kgf	4000 kgf	4500 kgf	5000 kgf	5500 kgf	6000 kgf	6500 kgf	7000 kgf
VPF-A1001C	2800	31.0	-	23.0	-	17.0	-	14.0 *	-	-	-	-	-	-	-	-
VPF-A1001M	6500	-	-	-	19.0	-	15.0	-	-	-	12.0	-	-	-	10.0	-
VPF-A1002C	3000	34.0	-	25.0	-	18.0	-	15.0	-	-	-	-	-	-	-	-
VPF-A1002F	5000	-	-	25.0	21.0	-	-	15.0	-	-	-	12.0	-	-	-	-
VPF-A1003C	2250	36.0	-	26.0	22.0	-	18.0 *	-	-	-	-	-	-	-	-	-
VPF-A1003E	3750	36.0	-	26.0	-	19.0	-	-	-	15.0 *	-	-	-	-	-	-
VPF-A1003F	5500	-	-	-	22.0	-	18.0	-	-	14.0	-	-	12.0	-	-	-
VPF-A1153C	2300	53.0	-	39.0	32.0	-	27.0 *	-	-	-	-	-	-	-	-	-
VPF-A1303B	1950	46.0	-	34.0	28.0	25.0 *	-	-	-	-	-	-	-	-	-	-
VPF-A1303F	4000	-	-	34.0	-	25.0	-	21.0	-	18.0	-	-	-	-	-	-
VPF-A1304A	1600	48.0	40.0	36.0 *	-	29.0 *	-	-	-	-	-	-	-	-	-	-
VPF-A1304D	3000	48.0	-	36.0	-	26.0	-	22.0	-	-	-	-	-	-	-	-
VPF-B1001M	6000	-	-	-	-	17.0	-	14.0	-	12.0	-	-	-	10.0	-	-
VPF-B1002E	3300	34.0	-	25.0	-	18.0	-	-	15.0 *	-	-	-	-	-	-	-
VPF-B1002M	6000	-	-	-	21.0	-	-	15.0	-	-	13.0	-	-	11.0	-	-
VPF-B1003C	2500	36.0	-	26.0	22.0	-	18.0	-	-	-	-	-	-	-	-	-
VPF-B1003F	4750	-	-	26.0	22.0	-	-	16.0	-	-	-	13.0 *	-	-	-	-
VPF-B1003T	7000	-	-	-	22.0	-	18.0	-	-	-	13.0	-	-	-	-	11.0
VPF-B1153E	3200	53.0	-	39.0	-	29.0	-	-	23.0*	-	-	-	-	-	-	-
VPF-B1153F	5000	-	-	39.0	-	29.0	-	24.0	-	-	-	19.0	-	-	-	-
VPF-B1303C	2250	46.0	-	34.0	28.0	-	24.0 *	-	-	-	-	-	-	-	-	-
VPF-B1303F	4000	-	-	34.0	-	25.0	-	21.0 *	-	18.0	-	-	-	-	-	-
VPF-B1304C	2150	48.0	-	36.0	31.0 *	-	25.0 *	-	-	-	-	-	-	-	-	-
VPF-B1304E	3500	-	-	36.0	30.0	-	25.0 *	-	20.0	-	-	-	-	-	-	-
VPF-B1652C	2700	64.0	-	47.0	39.0	-	-	30.0 *	-	-	-	-	-	-	-	-

(1) 1.0 kgf = 2.2 lbf or 9.8 N. An asterisk (\*) indicates a load rating that is measured at an rpm value that is less than the value listed for that column.

**Axial Load Force Ratings (zero radial load) for Brake Motors**

Motor Cat. No. <sup>(1)</sup>	Speed, max rpm	rpm														
		500 kgf	750 kgf	1000 kgf	1500 kgf	2000 kgf	2500 kgf	3000 kgf	3500 kgf	4000 kgf	4500 kgf	5000 kgf	5500 kgf	6000 kgf	6500 kgf	7000 kgf
VPF-A1001C	2800	49.4	-	36.5	-	27.0	-	23.4 *	-	-	-	-	-	-	-	-
VPF-A1001M	6500	-	-	-	30.6	-	24.5	-	-	-	19.0	-	-	-	16.2	-
VPF-A1002C	3000	49.4	-	36.5	-	27.0	-	22.7	-	-	-	-	-	-	-	-
VPF-A1002F	5000	-	-	36.5	30.6	-	-	22.7	-	-	-	18.2	-	-	-	-
VPF-A1003C	2250	49.4	-	36.5	30.6	-	25.7 *	-	-	-	-	-	-	-	-	-
VPF-A1003E	3750	49.4	-	36.5	-	27.0	-	-	-	20.6 *	-	-	-	-	-	-
VPF-A1003F	5500	-	-	-	30.6	-	24.5	-	-	20.0	-	-	17.4	-	-	-
VPF-A1153C	2300	68.3	-	50.5	42.4	-	35.2 *	-	-	-	-	-	-	-	-	-
VPF-A1303B	1950	68.3	-	50.5	42.4	37.8 *	-	-	-	-	-	-	-	-	-	-
VPF-A1303F	4000	-	-	50.5	-	37.4	-	31.4	-	27.7	-	-	-	-	-	-
VPF-A1304A	1600	68.3	57.2	51.1 *	-	41.2 *	-	-	-	-	-	-	-	-	-	-
VPF-A1304D	3000	68.3	-	50.5	-	37.4	-	31.4	-	-	-	-	-	-	-	-
VPF-B1001M	6000	-	-	-	-	27.0	-	22.7	-	20.0	-	-	-	16.8	-	-
VPF-B1002E	3300	49.4	-	36.5	-	27.0	-	-	21.8 *	-	-	-	-	-	-	-
VPF-B1002M	6000	-	-	-	30.6	-	-	22.7	-	-	19.0	-	-	16.8	-	-
VPF-B1003C	2500	49.4	-	36.5	30.6	-	24.5	-	-	-	-	-	-	-	-	-
VPF-B1003F	4750	-	-	36.5	30.6	-	-	22.7	-	-	-	18.6 *	-	-	-	-
VPF-B1003T	7000	-	-	-	30.6	-	24.5	-	-	-	19.0	-	-	-	-	15.7
VPF-B1153E	3200	68.3	-	50.5	-	37.4	-	-	30.5 *	-	-	-	-	-	-	-
VPF-B1153F	5000	-	-	50.5	-	37.4	-	31.4	-	-	-	25.1	-	-	-	-
VPF-B1303C	2250	68.3	-	50.5	42.4	-	35.5 *	-	-	-	-	-	-	-	-	-
VPF-B1303F	4000	-	-	50.5	-	37.4	-	31.8 *	-	27.7	-	-	-	-	-	-
VPF-B1304C	2150	68.3	-	50.5	43.6 *	-	36.2 *	-	-	-	-	-	-	-	-	-
VPF-B1304E	3500	-	-	50.5	42.4	-	35.2 *	-	29.3	-	-	-	-	-	-	-
VPF-B1652C	2700	90.1	-	66.7	55.9	-	-	43.3 *	-	-	-	-	-	-	-	-

(1) 1.0 kgf = 2.2 lbf or 9.8 N. An asterisk (\*) indicates a load rating that is measured at an rpm value that is less than the value listed for that column.

**Environmental Specifications**

Attribute	Value
Temperature, operating	0...40 °C (32...104 °F) <sup>(1)</sup>
Temperature, storage	-30...+70 °C (-22...+158 °F)
Relative humidity, storage	5...90% noncondensing
Atmosphere, storage	Noncorrosive
IP Ratings <sup>(2)(3)</sup>	See Kinetix Rotary Motion Specifications, publication <a href="#">KNX-TD001</a>

- (1) To obtain this thermal rating, mount the motor on a surface with heat dissipation equivalent to the size of an aluminum heatsink as listed here.  
 Frame 063 mm, 203.2 x 203.2 x 6.35 mm (8 x 8 x 0.25 in.)  
 Frame 075 mm, 254.0 x 254.0 x 6.35 mm (10 x 10 x 0.25 in.)  
 Frames 100...165 mm, 304.8 x 304.8 x 12.7 mm (12 x 12 x 0.5 in.)
- (2) The motors are dual rated with International Protection Codes (IP Ratings) for environmental protection. The motor rating excludes any reduction in the rating resulting from cables or their plugs.
- (3) The shaft seal kit is required to provide the specified IP rating for the motor. A system level rating is also dependent on the IP rating of the cable. See [Additional Resources on page 22](#) for shaft-seal installation instructions.

See the Kinetix Rotary and Linear Motion Cable Specifications Technical Data, publication [KNX-TD004](#), for connector kit catalog numbers.

## Motor Accessories

The following accessories are available for Kinetix food-grade servo motors.

### Kinetix 2090 Single Motor Cables

Factory-manufactured single motor cables are required with Kinetix VPF food-grade motors. Single motor cables are designed to effectively isolate the power and feedback or brake signals, within the cable. Single motor cables are available in configurable standard-cable lengths, and provide environmental and shield termination.

Contact your nearest Rockwell Automation sales office or see the Kinetix Rotary and Linear Motion Cable Specifications Technical Data, publication [KNX-TD004](#), for information about available Kinetix 2090 single motor cables.

### Shaft Seal Kits

Shaft seal kits are available as are replacement kits for field installation. A shaft seal provides a barrier that prevents moisture and particles from entering the motor bearings. Kinetix VPF food-grade motors are shipped with a Fluoroloy G4 (PTFE) shaft seal installed and kits include a lubricant to reduce wear.

**IMPORTANT** Shaft seals are subject to wear and require periodic inspection and replacement. Replacement is recommended every 3 months, not to exceed 12 months, depending on use. Shaft seals must be lubricated with a food-grade grease.

### Shaft Seal Kit Catalog Numbers

Motor Cat. No.	Shaft Seal Kit Cat. No.
VPF-A063xx and VPF-B063xx	VPF-SSN-F063075
VPF-A075xx and VPF-B075xx	
VPF-A100xx and VPF-B100xx	MPF-SST-A3B3
VPF-A115xx and VPF-B115xx	MPF-SST-A4B4
VPF-A130xx and VPF-B130xx	MPF-SST-A45B45
VPF-B165xx	MPF-SST-F165

See the Shaft-seal Kit Installation Instructions, publication [2090-IN012](#), for instructions on how to install a shaft seal.

### Positive Air-pressure Accessory Kit

A positive air-pressure kit (catalog number VPF-AIR-PURGE) is available for field installation on the M23 connector. Positive air pressure that is applied to the motor provides an extra level of protection against the ingress of foreign substances and moisture. The kit replaces the M23 connector cap, provides a replacement O-ring, and includes installation instructions.

You must supply these items with the sealing plug:

- Plastic tubing must be 4 mm (5/32 in.) OD Teflon™ fluorinated ethylene propylene (FEP) tubing.
- Air that is supplied to the motor must not exceed 0.1 bar (1.45 psi).



**ATTENTION:** Excessive air pressure or improper filtering of air can result in damage to the motor. Air that is supplied to the motor must be clean, dry, and of instrument quality. Maximum air pressure is 0.1 bar (1.45 psi). Failure to observe these safety procedures can result in personal injury or damage to equipment.

### Positive Air-pressure Kit Installation on the M23 Connector

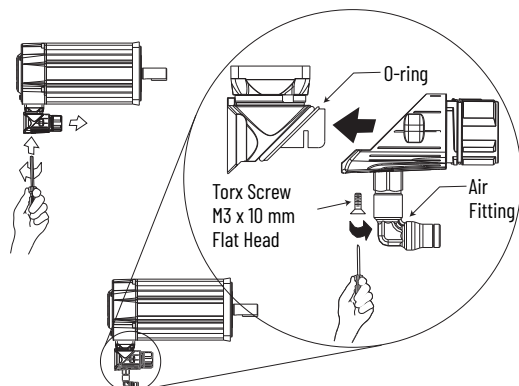

## Mounting Flange Washer Kits

Stainless steel washers inserted between the fastener head and motor flange are recommended as a best mounting practice and are included with Kinetix VPF motors. Replacement kits are also available.

**IMPORTANT** Stainless steel washers inserted between the fastener head and motor flange are also recommended as a best mounting practice and are included with Kinetix VPF motors. It is recommended to insert stainless steel washers (smooth side on paint) between the fastener head and motor flange.

### Washer Kit Catalog Numbers

Washer Kit Cat. No.	Motor Cat. No.
VPF-WSHR-F063075	VPF-A/B063xx
	VPF-A/B075xx
VPF-WSHR-F100	VPF-A/B100xx
VPF-WSHR-F115	VPF-A/B115xx
VPF-WSHR-F130	VPF-A/B130xx
VPF-WSHR-F165	VPF-B165xx

See the Kinetix VPF Food-grade Washer Kits Installation Instructions, publication [VPF-IN002](#), for an illustration.

## Additional Resources

These documents contain additional information concerning related products from Rockwell Automation. You can view or download publications at [rok.auto/literature](http://rok.auto/literature).

Resource	Description
Kinetix Rotary Motion Specifications Technical Data, publication <a href="#">KNX-TD001</a>	Provides product specifications for Kinetix VPL, VPC, VPF, VPH, VPS, Kinetix MPL, MPM, MPF, MPS; Kinetix TL and TLY, Kinetix RDB, Kinetix MMA, and Kinetix HPK rotary motors.
Kinetix 5700, 5500, 5300, 5100, and ArmorKinetix Servo Drives Specifications, publication <a href="#">KNX-TD003</a>	Provides product specifications for Kinetix Integrated Motion over EtherNet/IP™, Integrated Motion over sercos interface, EtherNet/IP networking, and component servo drive families.
Kinetix Rotary and Linear Motion Cable Specifications, publication <a href="#">KNX-TD004</a>	Product specifications for Kinetix 2090 motor and interface cables.
Kinetix 5500 Servo Drives User Manual, publication <a href="#">2198-UM001</a>	Provides information to install, configure, start up, and troubleshoot a Kinetix servo drive system with a servo motor.
Kinetix 5700 Servo Drives User Manual, publication <a href="#">2198-UM002</a>	
ArmorKinetix System User Manual, publication <a href="#">2198-UM006</a>	
Kinetix 5500 Drive System Design Guide, publication <a href="#">KNX-RM009</a>	Information on drive system components and accessory items you need for your Kinetix or ArmorKinetix drive/motor combination.
Kinetix 5700 Drive System Design Guide, publication <a href="#">KNX-RM010</a>	
Shaft Seal Kit Installation Instructions, publication <a href="#">2090-IN012</a>	Information on the installation of a shaft seal on this and other servo motors.
System Design for Control of Electrical Noise Reference Manual, publication <a href="#">GMC-RM001</a>	Information, examples, and techniques that are designed to minimize system failures that are caused by electrical noise.
Kinetix Food-grade Washer Kits Installation Instructions, publication <a href="#">VPF-IN002</a>	Information on stainless steel washers installed with the mounting fasteners on Kinetix VPF motors.
Product Certifications website, <a href="http://rok.auto/certifications">rok.auto/certifications</a>	Provides declarations of conformity, certificates, and other certification details.
Allen-Bradley Industrial Automation Glossary, publication <a href="#">AG-7.1</a>	A glossary of industrial automation terms and abbreviations.

**Notes:**

## Rockwell Automation Support

Use these resources to access support information.

<b>Technical Support Center</b>	Find help with how-to videos, FAQs, chat, user forums, Knowledgebase, and product notification updates.	<a href="http://rok.auto/support">rok.auto/support</a>
<b>Local Technical Support Phone Numbers</b>	Locate the telephone number for your country.	<a href="http://rok.auto/phonesupport">rok.auto/phonesupport</a>
<b>Technical Documentation Center</b>	Quickly access and download technical specifications, installation instructions, and user manuals.	<a href="http://rok.auto/techdocs">rok.auto/techdocs</a>
<b>Literature Library</b>	Find installation instructions, manuals, brochures, and technical data publications.	<a href="http://rok.auto/literature">rok.auto/literature</a>
<b>Product Compatibility and Download Center (PCDC)</b>	Download firmware, associated files (such as AOP, EDS, and DTM), and access product release notes.	<a href="http://rok.auto/pcdc">rok.auto/pcdc</a>

## Documentation Feedback

Your comments help us serve your documentation needs better. If you have any suggestions on how to improve our content, complete the form at [rok.auto/docfeedback](http://rok.auto/docfeedback).



## Waste Electrical and Electronic Equipment (WEEE)



At the end of life, this equipment should be collected separately from any unsorted municipal waste.

Rockwell Automation maintains current product environmental compliance information on its website at [rok.auto/pec](http://rok.auto/pec).

Rockwell Otomasyon Ticaret A.Ş. Kar Plaza İş Merkezi E Blok Kat:6 34752 İçerenköy, İstanbul, Tel: +90 (216) 5698400 EEE Yönetmeliğine Uygundur

Connect with us.    

[rockwellautomation.com](http://rockwellautomation.com)

expanding **human possibility**<sup>®</sup>

AMERICAS: Rockwell Automation, 1201 South Second Street, Milwaukee, WI 53204-2496 USA, Tel: (1) 414.382.2000

EUROPE/MIDDLE EAST/AFRICA: Rockwell Automation NV, Pegasus Park, De Kleetlaan 12a, 1831 Diegem, Belgium, Tel: (32) 2663 0600

ASIA PACIFIC: Rockwell Automation SEA Pte Ltd, 2 Corporation Road, #04-05, Main Lobby, Corporation Place, Singapore 618494, Tel: (65) 6510 6608

UNITED KINGDOM: Rockwell Automation Ltd., Pitfield, Kiln Farm, Milton Keynes, MK11 3DR, United Kingdom, Tel: (44)(1908) 838-800

Allen-Bradley, ArmorKinetix, expanding human possibility, Kinetix, and Rockwell Automation are trademarks of Rockwell Automation, Inc.

EtherNet/IP is a trademark of ODVA.

Trademarks not belonging to Rockwell Automation are property of their respective companies.

Publication VPF-INO01D-EN-P - September 2024 | Supersedes Publication VPF-INO01C-EN-P - August 2016

Copyright © 2024 Rockwell Automation, Inc. All rights reserved. Printed in the U.S.A.