

XM-320 Position Module

Catalog Number 1440-TPS02-01RB

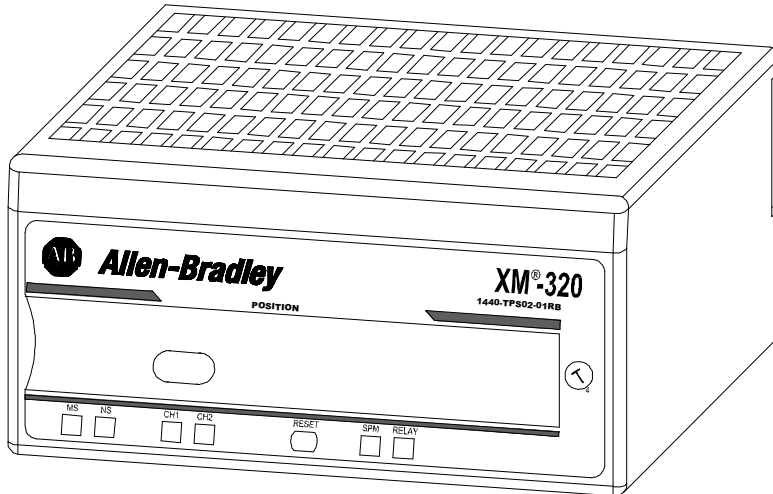

Topic	Page
Environment and Enclosure	3
European Hazardous Location Approval	4
North American Hazardous Location Approval	5
Mount the Module	6
Module Indicators	7
Self-Test	8
Reset Switch	9
Install the XM Serial Configuration Utility Software	9
Specifications	10
Additional Resources	12



Important User Information

Read this document and the documents listed in the additional resources section about installation, configuration, and operation of this equipment before you install, configure, operate, or maintain this product. Users are required to familiarize themselves with installation and wiring instructions in addition to requirements of all applicable codes, laws, and standards.

Activities including installation, adjustments, putting into service, use, assembly, disassembly, and maintenance are required to be carried out by suitably trained personnel in accordance with applicable code of practice.

If this equipment is used in a manner not specified by the manufacturer, the protection provided by the equipment may be impaired.

In no event will Rockwell Automation, Inc. be responsible or liable for indirect or consequential damages resulting from the use or application of this equipment.

The examples and diagrams in this manual are included solely for illustrative purposes. Because of the many variables and requirements associated with any particular installation, Rockwell Automation, Inc. cannot assume responsibility or liability for actual use based on the examples and diagrams.

No patent liability is assumed by Rockwell Automation, Inc. with respect to use of information, circuits, equipment, or software described in this manual.

Reproduction of the contents of this manual, in whole or in part, without written permission of Rockwell Automation, Inc., is prohibited.

Throughout this manual, when necessary, we use notes to make you aware of safety considerations.



WARNING: Identifies information about practices or circumstances that can cause an explosion in a hazardous environment, which may lead to personal injury or death, property damage, or economic loss.



ATTENTION: Identifies information about practices or circumstances that can lead to personal injury or death, property damage, or economic loss. Attentions help you identify a hazard, avoid a hazard, and recognize the consequence.

IMPORTANT

Identifies information that is critical for successful application and understanding of the product.

Labels may also be on or inside the equipment to provide specific precautions.



SHOCK HAZARD: Labels may be on or inside the equipment, for example, a drive or motor, to alert people that dangerous voltage may be present.



BURN HAZARD: Labels may be on or inside the equipment, for example, a drive or motor, to alert people that surfaces may reach dangerous temperatures.



ARC FLASH HAZARD: Labels may be on or inside the equipment, for example, a motor control center, to alert people to potential Arc Flash. Arc Flash will cause severe injury or death. Wear proper Personal Protective Equipment (PPE). Follow ALL Regulatory requirements for safe work practices and for Personal Protective Equipment (PPE).

Environment and Enclosure



ATTENTION: This equipment is intended for use in a Pollution Degree 2 industrial environment, in overvoltage Category II applications (as defined in IEC 60664-1), at altitudes up to 2000 m (6562 ft) without derating.

This equipment is not intended for use in residential environments and may not provide adequate protection to radio communication services in such environments.

This equipment is supplied as open-type equipment. It must be mounted within an enclosure that is suitably designed for those specific environmental conditions that will be present and appropriately designed to prevent personal injury resulting from accessibility to live parts. The enclosure must have suitable flame-retardant properties to prevent or minimize the spread of flame, complying with a flame spread rating of 5VA or be approved for the application if nonmetallic. The interior of the enclosure must be accessible only by the use of a tool. Subsequent sections of this publication may contain additional information regarding specific enclosure type ratings that are required to comply with certain product safety certifications.

In addition to this publication, see the following:

- Industrial Automation Wiring and Grounding Guidelines, publication [1770-4.1](#), for additional installation requirements
- NEMA Standard 250 and IEC 60529, as applicable, for explanations of the degrees of protection provided by enclosures



ATTENTION: To comply with UL/CSA restrictions and the CE Low Voltage Directive (LVD), all connections to this equipment must be powered from a single source compliant with the following:

- A Listed Class 2 power supply, or a Listed ITE safety extra low voltage (SELV) power supply with the 1440-5AFUSEKIT fuse kit, or a protected extra low voltage (PELV) power supply certified to 60950 with the 1440-5AFUSEKIT fuse kit.
- The same power source must power any device to which the module is connected via its side connector⁽¹⁾ or any of its non-isolated circuits that include: power, XMbus, 4 . . 20 mA outputs, and setpoint multiplier circuits.⁽²⁾

(1) Power transmission across the XM module side connector must not exceed 3 A.

(2) These circuits are all functionally isolated, but do not have adequate insulation to satisfy the isolation requirements of some electrical safety standards. Therefore the ground requirements for the circuits, specified in the individual user's manuals, must still be applied.

Prevent Electrostatic Discharge



ATTENTION: This equipment is sensitive to electrostatic discharge, which can cause internal damage and affect normal operation. Follow these guidelines when you handle this equipment:

- Touch a grounded object to discharge potential static.
- Wear an approved grounding wriststrap.
- Do not touch connectors or pins on component boards.
- Do not touch circuit components inside the equipment.
- Use a static-safe workstation, if available.
- Store the equipment in appropriate static-safe packaging when not in use.



ATTENTION: The serial communication port is intended for temporary local-programming purposes only and **not** intended for permanent connection. The serial cable and power connections are not to exceed 3.0 m (9.84 ft):

- This product is intended to be mounted to a well-grounded mounting surface such as a metal panel or DIN rail. For DIN rail mounting, use zinc plated yellow-chromate steel DIN rail to assure proper grounding. The use of other DIN rail materials (for example, aluminum or plastic) that can corrode, oxidize, or are poor conductors, can result in improper or intermittent grounding. Secure DIN rail to mounting surface approximately every 200 mm (7.8 in.) and use end-anchors appropriately.
- Do not remove or replace a terminal base unit while power is applied. Interruption of the backplane can result in unintentional operation or machine motion.
- This module is designed so you can remove and insert it under power. However, when you remove or insert the module with power applied, I/O attached to the module can change states due to its input/output signal changing conditions. Take special care when using this feature.

IMPORTANT

Install the overlay slide label to protect the serial connector and electronics when the serial port is not in use.

European Hazardous Location Approval

The following applies when the product bears the Ex Marking

This equipment is intended for use in potentially explosive atmospheres as defined by European Union Directive 94/9/EC and has been found to comply with the Essential Health and Safety Requirements relating to the design and construction of Category 3 equipment intended for use in Zone 2 potentially explosive atmospheres, given in Annex II to this Directive.

Compliance with the Essential Health and Safety Requirements has been assured by compliance with EN 60079-0, EN 60079-15 and EN 60079-11.



WARNING: The installation of the XM-320 module includes the following warnings:

- This equipment must be mounted in an ATEX-certified enclosure with a minimum ingress protection rating of at least IP54 (as defined in IEC60529), and used in an environment of not more than Pollution Degree 2 (as defined in IEC 60664-1) when applied in Zone 2 environments. The enclosure must have a tool-removable cover or door.
 - This equipment must be used within its specified ratings defined by Rockwell Automation.
 - Provision must be made to prevent the rated voltage from being exceeded by transient disturbances of more than 140% of the rated voltage when applied in Zone 2 environments.
 - This equipment must be used only with ATEX-certified Allen-Bradley terminal base units.
 - Secure any external connections that mate to this equipment by using screws, sliding latches, threaded connectors, or other means provided with this product.
 - Do not disconnect equipment unless power has been removed or the area is known to be nonhazardous.
 - Connection of the modules to barriers and/or sensors located in dangerous areas is the responsibility of the user.
 - The XM-320 module must be installed in accordance with specification control sheets 48238-HAZ and 48239-HAZ.
-

North American Hazardous Location Approval

The following information applies when operating this equipment in hazardous locations.	Informations sur l'utilisation de cet équipement en environnements dangereux.	
<p>Products marked "CL I, DIV 2, GP A, B, C, D" are suitable for use in Class I Division 2 Groups A, B, C, D, Hazardous Locations and nonhazardous locations only. Each product is supplied with markings on the rating nameplate indicating the hazardous location temperature code. When combining products within a system, the most adverse temperature code (lowest "T" number) may be used to help determine the overall temperature code of the system. Combinations of equipment in your system are subject to investigation by the local Authority Having Jurisdiction at the time of installation.</p>	<p>Les produits marqués "CL I, DIV 2, GP A, B, C, D" ne conviennent qu'à une utilisation en environnements de Classe I Division 2 Groupes A, B, C, D dangereux et non dangereux. Chaque produit est livré avec des marquages sur sa plaque d'identification qui indiquent le code de température pour les environnements dangereux. Lorsque plusieurs produits sont combinés dans un système, le code de température le plus défavorable (code de température le plus faible) peut être utilisé pour déterminer le code de température global du système. Les combinaisons d'équipements dans le système sont sujettes à inspection par les autorités locales qualifiées au moment de l'installation.</p>	
	<p>EXPLOSION HAZARD -</p> <ul style="list-style-type: none"> Do not disconnect equipment unless power has been removed or the area is known to be nonhazardous. Do not disconnect connections to this equipment unless power has been removed or the area is known to be nonhazardous. Secure any external connections that mate to this equipment by using screws, sliding latches, threaded connectors, or other means provided with this product. Substitution of components may impair suitability for Class I, Division 2. If this product contains batteries, they must only be changed in an area known to be nonhazardous. 	<p>RISQUE D'EXPLOSION –</p> <ul style="list-style-type: none"> Couper le courant ou s'assurer que l'environnement est classé non dangereux avant de débrancher l'équipement. Couper le courant ou s'assurer que l'environnement est classé non dangereux avant de débrancher les connecteurs. Fixer tous les connecteurs externes reliés à cet équipement à l'aide de vis, loquets coulissants, connecteurs filetés ou autres moyens fournis avec ce produit. La substitution de composants peut rendre cet équipement inadapté à une utilisation en environnement de Classe I, Division 2. S'assurer que l'environnement est classé non dangereux avant de changer les piles.



WARNING: The installation of the XM-320 module includes the following warnings:

- When you insert or remove the module while power is on, an electrical arc can occur. This could cause an explosion in hazardous location installations. Be sure that power is removed or the area is nonhazardous before proceeding.
- If you connect or disconnect the serial cable with power applied to this module or the serial device on the other end of the cable, an electrical arc can occur. This could cause an explosion in hazardous location installations. Be sure that power is removed or the area is nonhazardous before proceeding.
- If you connect or disconnect the XMBus cable with power applied to this module or any device on the network, an electrical arc can occur. This could cause an explosion in hazardous location installations. Be sure that power is removed or the area is nonhazardous before proceeding.
- If you connect or disconnect wiring while the field-side power is on, an electrical arc can occur. This could cause an explosion in hazardous location installations. Be sure that power is removed or the area is nonhazardous before proceeding.
- When you press the reset button while power is on, an electrical arc can occur. This could cause an explosion in hazardous location installations. Be sure that power is removed or the area is nonhazardous before proceeding.
- Wiring to or from the XM-320 module, which enters or leaves the system enclosure, must utilize wiring methods suitable for Class I, Division 2 Hazardous Locations, as appropriate for the installation in accordance with the following product drawings:
 - Without Barriers - 48238-HAZ
 - With Barriers - 48239-HAZ

Mount the Module

The XM® 320 mounts on a XM-941 terminal base unit, catalog number 1440-TB-B. We recommend that you mount the module after you have connected the wiring on the terminal base unit. Refer to the XM-941 Terminal Base Installation Instruction, publication [GMSI10-IN021](#), or the XM-320 Position Module User Guide, publication [GMSI10-UM005](#), for wiring information.



ATTENTION: The XM-320 module is compatible only with the XM-941 terminal base unit. Verify that the keyswitch on the terminal base unit is at position 4 for the XM-320 module.

Do not attempt to install XM-320 modules on other terminal base units.

Do not change the position of the keyswitch after wiring the XM-941 terminal base unit.

1. Make certain the keyswitch (A) on the terminal base unit (C) is at position 4 as required for the XM-320 module.

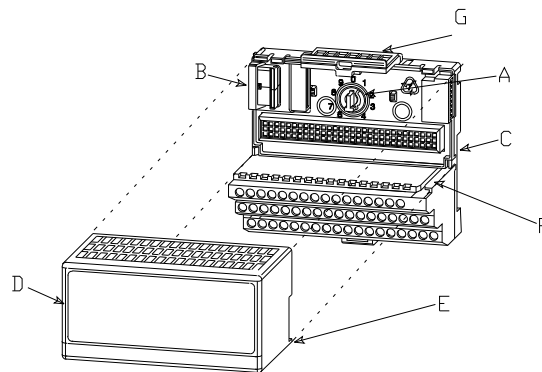

2. Make certain the side connector (B) is pushed all the way to the left.
You cannot install the module unless the connector is fully extended.
3. Make sure that the pins on the bottom of the module are straight so they align properly with the connector in the terminal base unit.
4. Position the module (D) with its alignment bar (E) aligned with the groove (F) on the terminal base unit.
5. Press firmly and evenly to seat the module in the terminal base unit.
The module is seated when the latching mechanism (G) is locked into the module.
6. Repeat the above steps to install the next module in its terminal base unit.

All grounds in the system must be tied to the same point of the same grounding electrode system.

Maintain a 2.54 cm (1 in.) minimum clearance between the module and adjacent equipment. There are no orientation restrictions.

Module Indicators

The XM-320 has six status indicators, which are on top of the module.

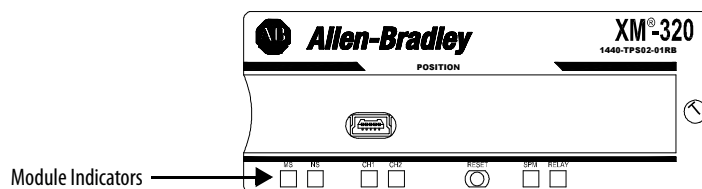

Module Status (MS) Indicator

Color	State	Description
No color	Off	No power applied to the module.
Green	Flashing Red	Module performing power-up self-test.
	Flashing	Module operating in Program mode. ⁽¹⁾
	Solid	Module operating in Run mode. ⁽²⁾
Red	Flashing	<ul style="list-style-type: none"> Application firmware is invalid or not loaded. Download firmware to the module. Firmware download is currently in progress.
	Solid	An unrecoverable fault has occurred. It is possible that the module must be repaired or replaced.

(1) Program mode - Typically this occurs when the module configuration settings are being updated with the Serial Configuration Utility. In Program mode, the module does not perform its normal functions. The signal processing/measurement process is stopped, and the status of the alarms is set to the disarm state to prevent a false alert or danger status.

(2) Run mode - In Run mode, the module collects measurement data and monitors each measurement device.

Network Status (NS) Indicator

Color	State	Description
No color	Off	Module is not online: <ul style="list-style-type: none"> Module is autobauding. No power applied to the module; look at Module Status indicator.
Green	Flashing	Module is online (DeviceNet network) but no connections are currently established. ⁽¹⁾
	Solid	Module is online with connections currently established.
Red	Flashing	One or more I/O connections are in the timed-out-state.
	Solid	Failed communication (duplicate MAC ID or bus-off).

(1) Normal operation when the module is not a slave to an XM-320, programmable controller, or other master device.

Channel 1 and Channel 2 Status Indicator

Color	State	Description
No color	Off	<ul style="list-style-type: none"> Normal operation with alarm limits on the channel. No power applied to the module; look at Module Status indicator.
Yellow	Solid	An alert level alarm condition exists on the channel (and no transducer fault or danger level alarm condition exists).
Red	Solid	A danger level alarm condition exists on the channel (and no transducer fault condition exists).
	Flashing	A transducer fault condition exists on the channel.

Setpoint Multiplier Indicator

Color	State	Description
Yellow	Off	Setpoint multiplier is not in effect.
	Solid	Setpoint multiplier is in effect.

Relay Indicator

Color	State	Description
Red	Off	On-board relay is not activated.
	Solid	On-board relay is activated.

Self-Test

The XM-320 module performs a self-test at powerup. The self-test includes a status indicator test and a device test. During the status indicator test, the indicators are turned on independently and in sequence for approximately 0.25 seconds.

The device test occurs after the status indicator test. The Module Status (MS) indicator is used to indicate the status of the device self-test.

MS Indicator State	Description
Flashing red and green	Device self-test is in progress.
Solid green or flashing green	Device self-test completed successfully, and the firmware is valid and running.
Flashing red	Device self-test completed, the hardware is OK, but the firmware is invalid. Or, the firmware download is in progress.
Solid red	Unrecoverable fault, hardware failure, or Boot Loader program corruption.

Reset Switch

The XM-320 module has an external reset switch on top of the module. The Reset switch can be used to reset all latched relays, including the relays in the Relay Expansion module when it is attached to the XM-320 module.

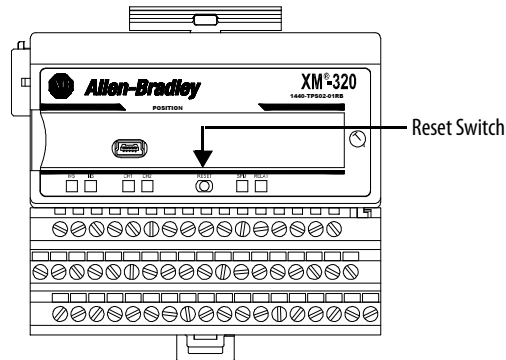

IMPORTANT The Reset switch resets the relays only if the input is no longer in alarm or the condition that caused the alarm is no longer present.

Install the XM Serial Configuration Utility Software

The XM Documentation and Configuration Utility CD is packaged with the XM modules. It contains the XM Serial Configuration Utility software, a set of user guides, hazardous location installation drawings, and electronic data sheet (EDS) files that are used by network configuration tools such as RSNetWorx™ for DeviceNet software. The user guides are in portable document format (PDF), and must be viewed with Adobe Acrobat Reader software.

To install the XM Serial Configuration Utility software, follow these steps.

1. Insert the XM Documentation and Configuration Utility CD-ROM into the CD-ROM drive.

If autorun is	Then
Enabled	The Setup program starts automatically and the XM Serial Configuration Utility opening screen appears.
Disabled	Follow these steps. 1. Click Start, and then click Run. The Run dialog box appears. 2. In the Open box, type <code>x:\autorun</code> , where x is the letter of the drive containing the XM Documentation and Configuration Utility CD-ROM. 3. Click OK. The XM Serial Configuration Utility opening screen appears.

2. Follow the instructions that appear to install the XM Serial Configuration Utility.
3. When you are finished installing the software, remove the XM Documentation and Configuration Utility CD-ROM from the CD-ROM drives; store it in a safe place.

Specifications

The following table lists the technical specifications for the XM-320 module.

Attribute	XM-320
Temperature, operating IEC 60068-2-1 (Test Ad, Operating Cold), IEC 60068-2-2 (Test Bd, Operating Dry Heat), IEC 60068-2-14 (Test Nb, Operating Thermal Shock)	-20...65 °C (-4...149 °F)
Temperature, surrounding air, max	65 °C (149 °F)
Temperature, nonoperating IEC 60068-2-1 (Test Ab, Unpackaged Nonoperating Cold), IEC 60068-2-2 (Test Bb, Unpackaged Nonoperating Dry Heat), IEC 60068-2-14 (Test Na, Unpackaged Nonoperating Thermal Shock)	-40...85 °C (-40...185 °F)
Relative humidity IEC 60068-2-30 (Test Db, Unpackaged Damp Heat)	5...95% noncondensing
Vibration IEC 60068-2-6 (Test Fc, Operating)	2 g @ 10...500 Hz
Shock, operating IEC 60068-2-27 (Test Ea, Unpackaged Shock)	15 g
Shock, nonoperating IEC 60068-2-27 (Test Ea, Unpackaged Shock)	20 g
Emissions CISPR 11 (IEC 61000-6-4)	Class A
ESD immunity IEC 61000-4-2	8 kV contact discharges 8 kV air discharges
Radiated RF immunity IEC 61000-4-3	10V/m with 1 kHz sine-wave 80% AM from 80...2000 MHz 10V/m with 200 Hz 50% Pulse 100% AM at 900 MHz 10V/m with 200 Hz 50% Pulse 100% AM at 1890 MHz 3V/m with 1 kHz sine-wave 80% AM from 2000...2700 MHz
EFT/B immunity IEC 61000-4-4	±2 kV at 5 kHz on power ports ±1 kV at 5 kHz on relay and shielded signal ports ±1 kV at 5 kHz on XMBus port
Surge transient immunity IEC 61000-4-5	±1 kV line-earth(CM) on relay ports ±2 kV line-earth(CM) on shielded signal ports ±2 kV line-earth(CM) on XMBus port
Conducted RF immunity	IEC 61000-4-6: 10V rms with 1 kHz sine-wave 80% AM from 150 kHz...80 MHz
Enclosure type rating	None (open-style)
Voltages/ranges	Supply: 24V DC, 0.2 A max, Class 2/SELV Relay: 120V AC, 50/60Hz, 0.5 A resistive 110V DC, 0.3 A resistive 30V DC, 1.0 A resistive
Power dissipation	5.3 W max
External over-current protection	440-5AFUSEKIT for SELV/PELV power sources

Attribute	XM-320
Isolation voltage	250V (continuous), Basic Insulation Type, relay to all other circuits. Isolation between other circuits is not rated. Type tested at 1500V AC for 60 s
Wiring category ⁽¹⁾	2 - on relay and shielded signal ports 3 - on Serial and power ports 2 - on XMbus ports
Wire type	Signal connections: shielded Power and relay connections: unshielded
Pilot duty rating	Relay port: Not rated
North American temp code	T4A
IEC temp code	T4

(1) Use this Conductor Category information for planning conductor routing. Refer to Industrial Automation Wiring and Grounding Guidelines, publication [1770-4.1](#).

Certifications

Certification ⁽¹⁾ (when product is marked)	Description
c-UL-us	UL Listed Industrial Control Equipment, certified for US and Canada. See UL File E234338.
c-CSA-us	CSA Certified Process Control Equipment for Class I, Division 2 Group A,B,C,D Hazardous Locations, certified for US and Canada. See CSA File 150115.
CE	European Union 2004/108/EC EMC Directive, compliant with: <ul style="list-style-type: none"> EN 61326-1; Meas./Control/Lab., Industrial Requirements EN 61000-6-2; Industrial Immunity EN 61000-6-4; Industrial Emissions EN 61131-2; Programmable Controllers (Clause 8, Zone A & B) European Union 2006/95/EC LVD, compliant with: <ul style="list-style-type: none"> EN 61131-2; Programmable Controllers (Clause 11)
C-Tick	Australian Radiocommunications Act, compliant with: <ul style="list-style-type: none"> AS/NZS CISPR 11; Industrial Emissions
Ex	European Union 94/9/EC ATEX Directive, compliant with: <ul style="list-style-type: none"> EN 60079-15; Potentially Explosive Atmospheres, Protection "n" EN 60079-11; Explosive Atmospheres, Protection "i" EN 60079-0; General Requirements II 3 G Ex nAC [ic] IIC T4X Gc when used at or below 60V AC or 75V DC
KC	Korean Registration of Broadcasting and Communications Equipment, compliant with: <ul style="list-style-type: none"> Article 58-2 of Radio Waves Act, Clause 3

(1) See the Product Certification link at <http://www.rockwellautomation.com> for Declarations of Conformity, Certificates, and other certification details.

Additional Resources

For more information on the products described in this publication, use these resources.

Resource	Description
1440 XM Monitoring Modules Specifications Technical Data, publication 1440-TD001	Provides technical specifications for the 1440 series of monitoring modules.
XM-320 Position Module User Guide, publication GMS110-UM005	Provides information about how to install and configure the XM-320 Position Module, along with technical specifications and DeviceNet information and objects for the module.

You can view or download Rockwell Automation publications at <http://www.rockwellautomation.com/literature/>. To order paper copies of technical documentation, contact your local Allen-Bradley distributor or Rockwell Automation sales representative.

Allen-Bradley, Rockwell Software, Rockwell Automation, XM, RSNetWorx, and LISTEN.THINK.SOLVE. are trademarks of Rockwell Automation, Inc.

Trademarks not belonging to Rockwell Automation are property of their respective companies.

Rockwell Otomasyon Ticaret A.Ş., Kar Plaza İş Merkezi E Blok Kat:6 34752 İçerenköy, İstanbul, Tel: +90 (216) 5698400

www.rockwellautomation.com

Power, Control and Information Solutions Headquarters

Americas: Rockwell Automation, 1201 South Second Street, Milwaukee, WI 53204-2496 USA, Tel: (1) 414.382.2000, Fax: (1) 414.382.4444

Europe/Middle East/Africa: Rockwell Automation NV, Pegasus Park, De Kleetlaan 12a, 1831 Diegem, Belgium, Tel: (32) 2 663 0600, Fax: (32) 2 663 0640

Asia Pacific: Rockwell Automation, Level 14, Core F, Cyberport 3, 100 Cyberport Road, Hong Kong, Tel: (852) 2887 4788, Fax: (852) 2508 1846

Publication ENMON-IN320H-EN-P - February 2014

Supersedes Publication ENMON-IN320G-EN-P - October 2012

PN-210602

Copyright © 2014 Rockwell Automation, Inc. All rights reserved. Printed in the U.S.A.