

# PowerFlex 755 Common DC Input Drives, Frames 8...10 Interlock Assembly and Precharge Assembly Left-front Cover Retrofit Kit

Catalog Numbers 20G14x, 21G14x

Topic	Page
General Precautions	1
Before You Begin	1
Install the Retrofit Kit	2
Additional Resources	11

This retrofit kit can be used to improve the access to the molded case switch (SW1) on common DC input drives for lock-out, tag-out procedures. Install this kit only on DC input with precharge modules with catalog numbers 20-750-P5-C770D740 and 20-750-P5-E510F500.

## General Precautions



### ATTENTION:

- Only qualified personnel familiar with adjustable frequency AC drives and associated machinery should plan or implement the installation, start-up and subsequent maintenance of the system. Failure to comply may result in personal injury and/or equipment damage.
- This drive contains ESD (Electrostatic Discharge) sensitive parts and assemblies. Static control precautions are required when you install, test, service, or repair this assembly. Component damage may result if ESD control procedures are not followed. If you are not familiar with static control procedures, reference Guarding Against Electrostatic Damage, publication 8000-4.5.2 or any other applicable ESD protection handbook.

## Before You Begin

Before you install the retrofit kit, complete these tasks:

- Review the parts list and verify that you have all items that are listed, page [2](#)
- Gather the tools that are required to install the kit, page [2](#)

## Kit Parts List

This kit contains the following parts.

- DC precharge left-front cover with access panel
- DC bus guard
- Interlock assembly
- L-bracket and two M5 x 14 mm hexalobular screws

## Required Tools

Tool Description	Details
Allen socket wrench	2.5 mm
ESD-protected place of work	Work surface, Floor cover, seat, and ground connections
ESD-protective clothing	Wrist wrap, shoes, overall clothing (coat)
Flash light	–
Hexalobular screw driver/bit	#20, #25
Multi-meter	Digital multi-meter, capable of AC and DC voltage, continuity, resistance, capacitance measurements, and forward diode bias tests. Fluke model 87 III or equivalent.
Nose pliers	–
Phillips screw driver / bit	#1

## Install the Retrofit Kit

Follow these steps to install the interlock assembly and precharge assembly, left cover retrofit kit.

## Remove Power from the Drive



**ATTENTION:** To avoid an electric shock hazard, verify that the voltage on the bus capacitors has discharged completely before servicing. Measure the DC bus voltage at the -DC and +DC TESTPOINT sockets on the front of the power module (show in the illustration in [step 3](#)).

Remove power before you remove or make cable connections. When you remove or insert a cable connector with power applied, an electrical arc may occur. An electrical arc may cause these system events, which can cause personal injury or property damage.

- An erroneous signal to system field devices, which can cause unintended machine motion
- An explosion in a hazardous environment

Electrical arcing causes excessive wear to contacts on both the module and its mating connector. Worn contacts can create electrical resistance.

1. Turn off and lock out all input power, including any external power sources (such as an AFE or other DC power source).
2. Wait 15 minutes and verify that there is no voltage at the drive input-power terminals.

3. Measure the DC bus voltage at the -DC and +DC TESTPOINT sockets on the front of the power module.

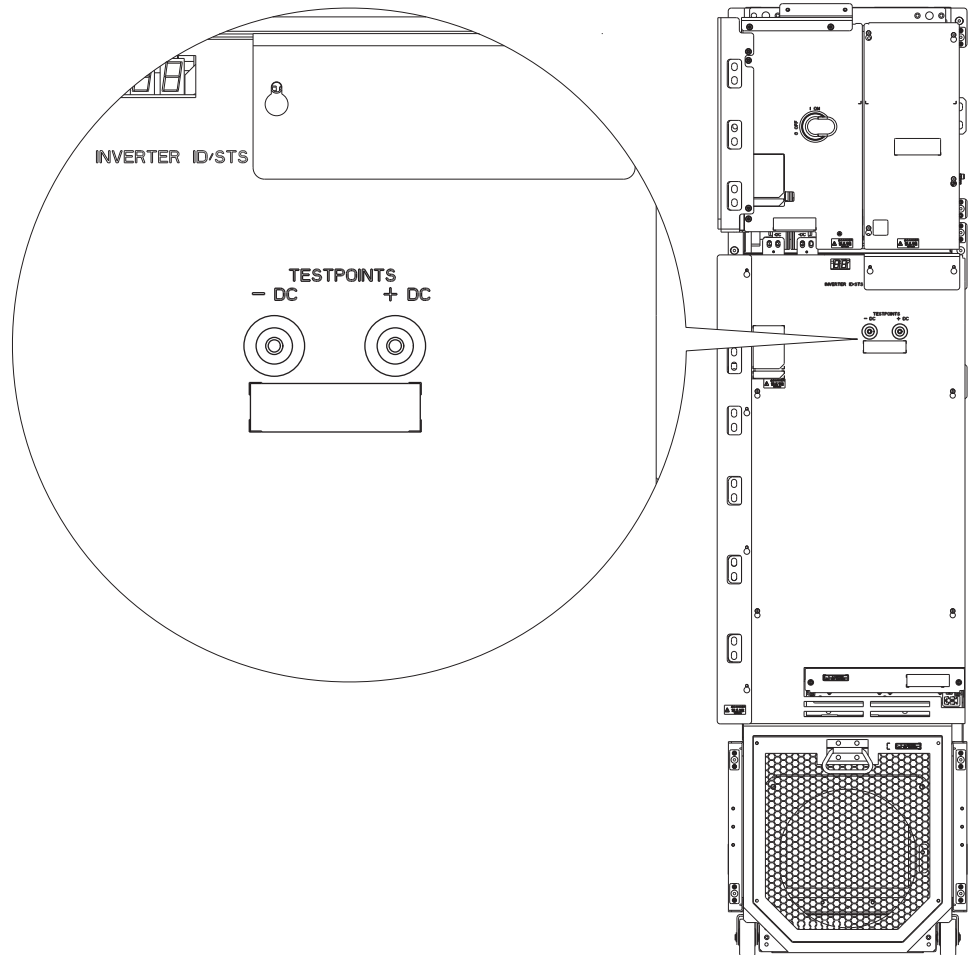



**ATTENTION:** To avoid an electric shock hazard when servicing the drive, a means for Lockout/Tagout of the external, single-phase 120/240V and, if present, 120V uninterruptible power supply sources must be provided.

4. Turn off and lock the drive circuit breaker SW5 (if used).
5. Turn off the drive disconnect switch SW2.

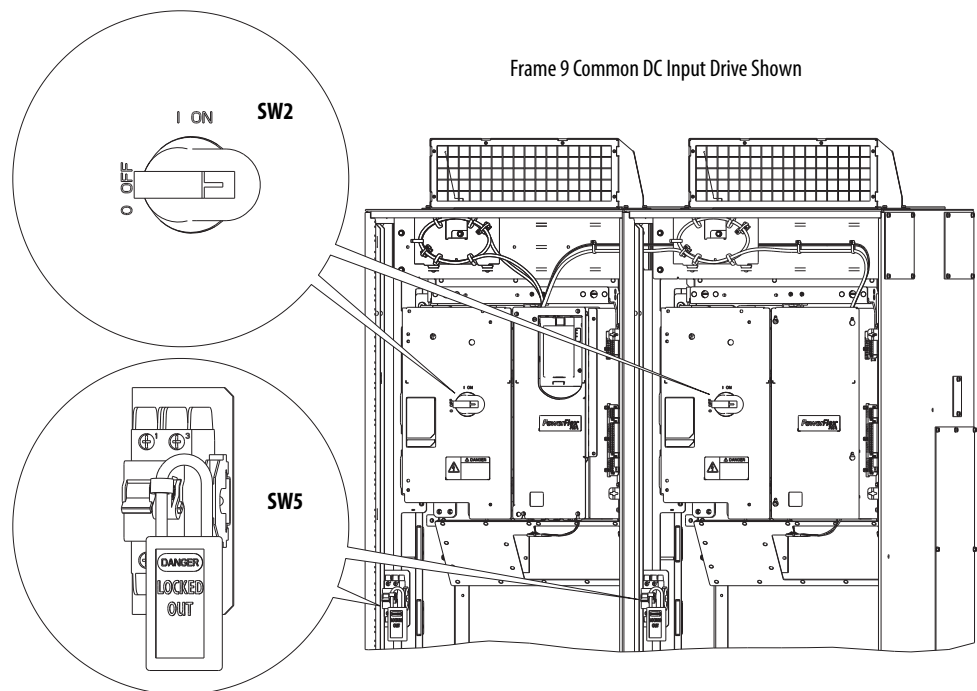

## Remove the DC Precharge Left-front Cover and Disconnect Switch Handle and Handle Shaft

1. Remove only the four M5 x 14 mm screws that secure the DC precharge left-front cover to the assembly and remove the cover and top and left guards.
2. Remove the four M5 x 14 mm screws that secure the top and left guards to the cover, and remove the guards. Retain the guards and screws for reuse.

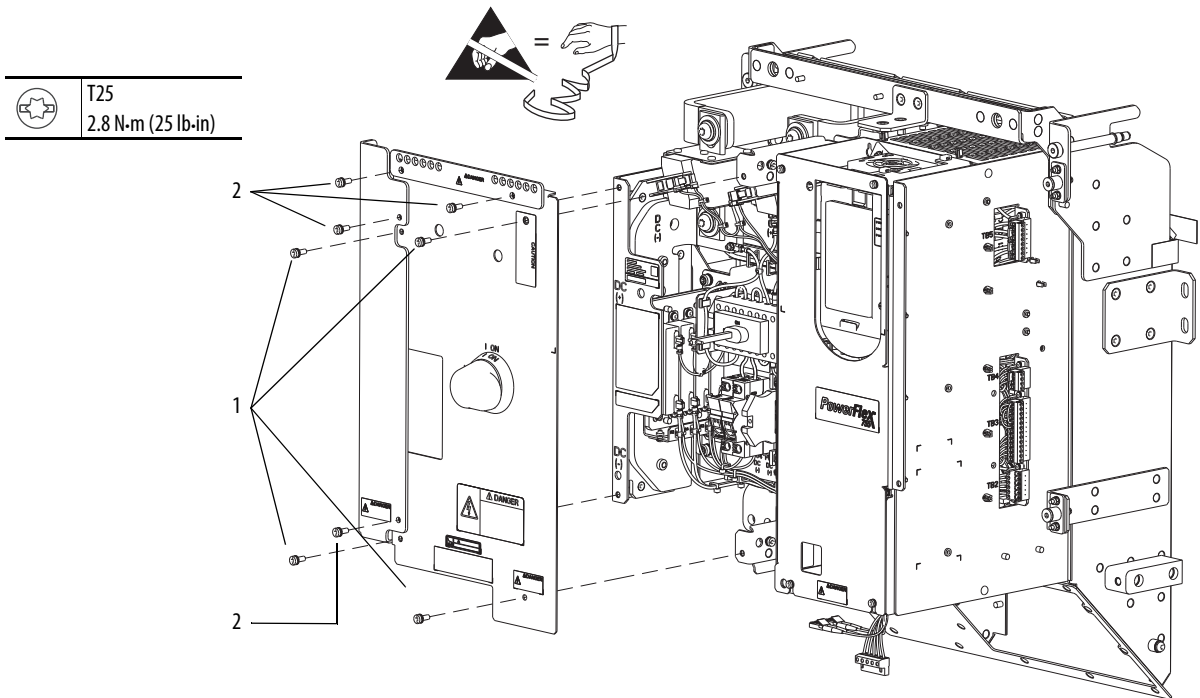

3. Remove the two M4 x 12 mm hexalobular screws and washers that secure the rotary disconnect on/off handle to the front cover and remove the handle. Retain the handle, screws, and washers for reuse.

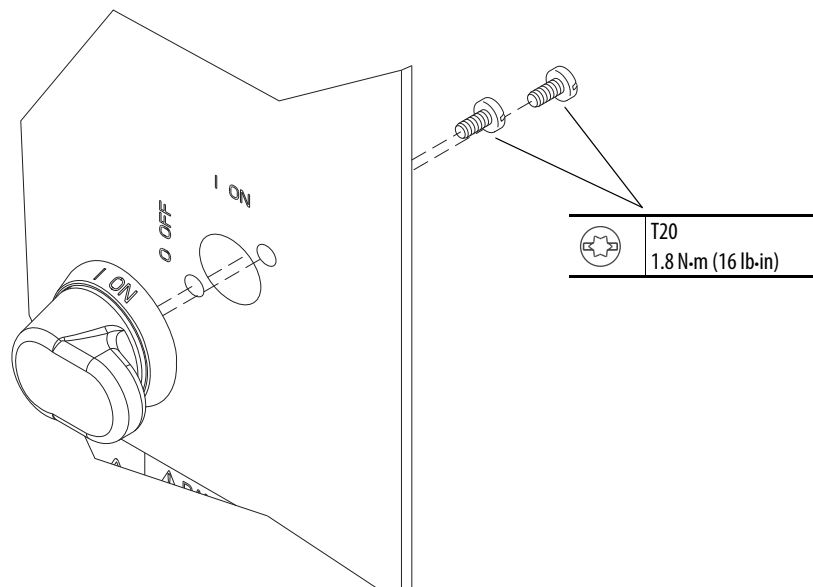

4. Loosen the hexagonal screw that secures the disconnect handle shaft to the disconnect switch and remove the handle.

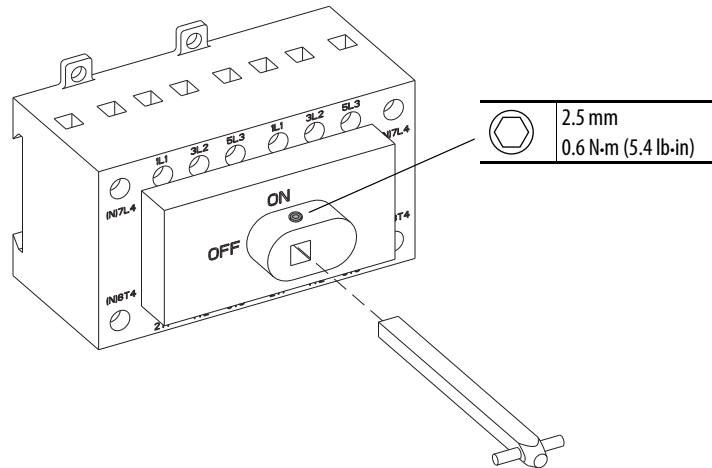

### Install the New Disconnect Switch Interlock Assembly

1. Complete steps a....d to install the interlock assembly on the disconnect handle shaft.
  - a. Position the interlock rod (A) under the clamp assembly (as shown in the illustration).
  - b. Position the set screw (B) to the right of the clamp assembly.
  - c. Position the pins (C) on the disconnect handle shaft vertically and slide the base of the shaft through the square opening in the clamp assembly.

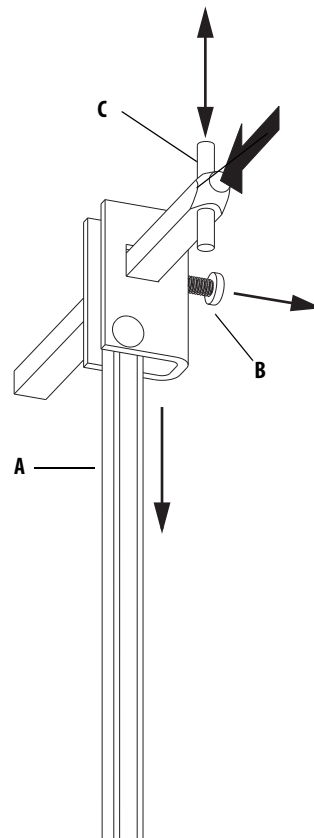

- d. Position the back of the interlock clamp assembly 34 mm (1.33 in.) from the base of the shaft and tighten the M3 x 1.5 mm set screw.

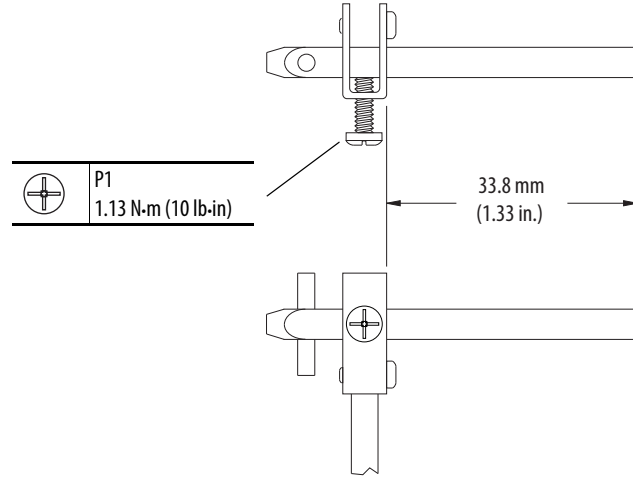

2. With the interlock rod (D) positioned below the handle shaft, fully insert the handle shaft (E) into the receptacle on the disconnect switch.

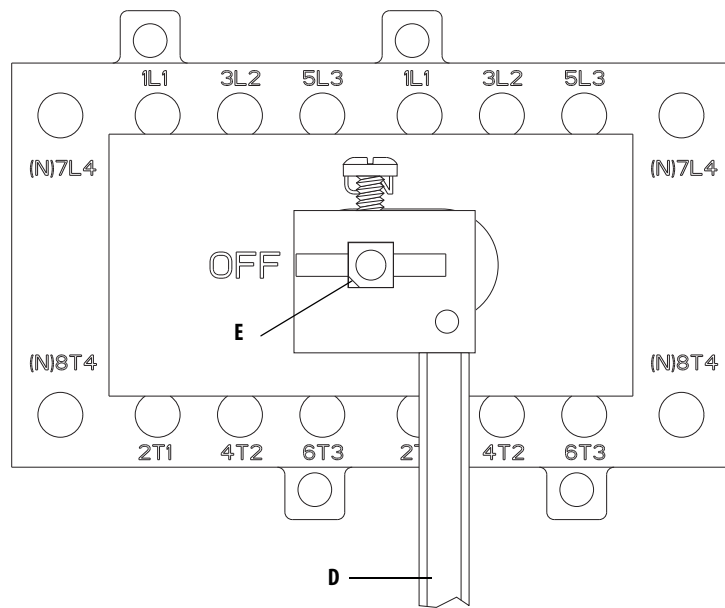

3. Secure the handle shaft in place by using the set screw on the disconnect switch.

See [step 4](#) of Remove the DC Precharge Left-front Cover and Disconnect Switch Handle and Handle Shaft on page [5](#) for recommended torque.

## Replace the DC Bus Guard

1. By using a pliers, remove the four cable tie mounts, which secure the resistor wires, from the back of the existing DC bus guard.
2. Loosen the two M4 x 12 mm hexalobular screws that secure the clear, plastic shield to the front of the DC bus guard and remove the plastic panel. Retain this panel for reuse.
3. Loosen the two M4 x 12 mm hexalobular screws that secure the sheet metal DC bus guard to the resistor assembly and remove and discard the guard.

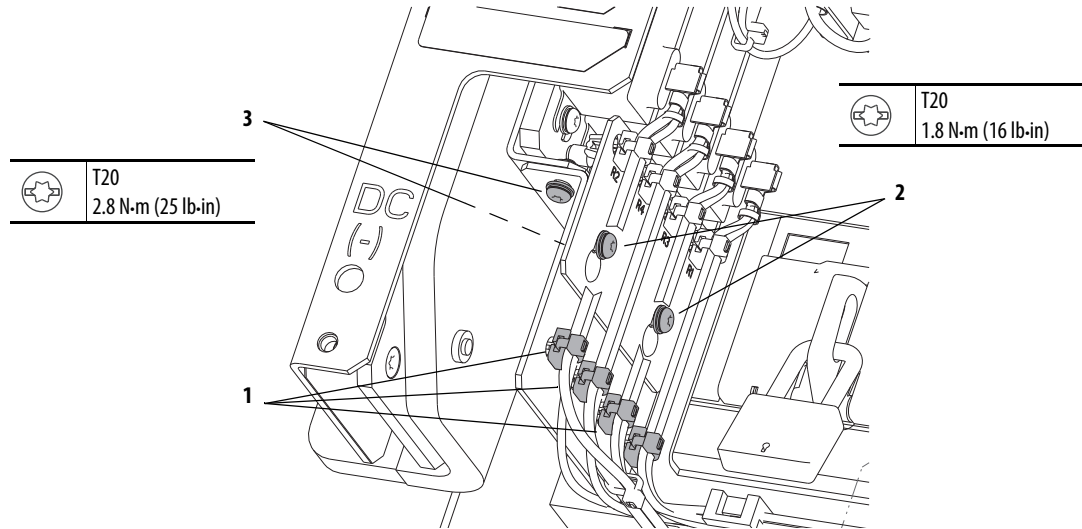

4. Place the new sheet metal DC bus guard on the resistor assembly and secure the guard by tightening the two existing screws.
5. Place the clear, plastic shield on the new DC bus guard and secure the shield by tightening the existing screws.
6. Fully insert the four cable tie mounts, which secure the resistor wires, into the holes on the new DC bus guard.

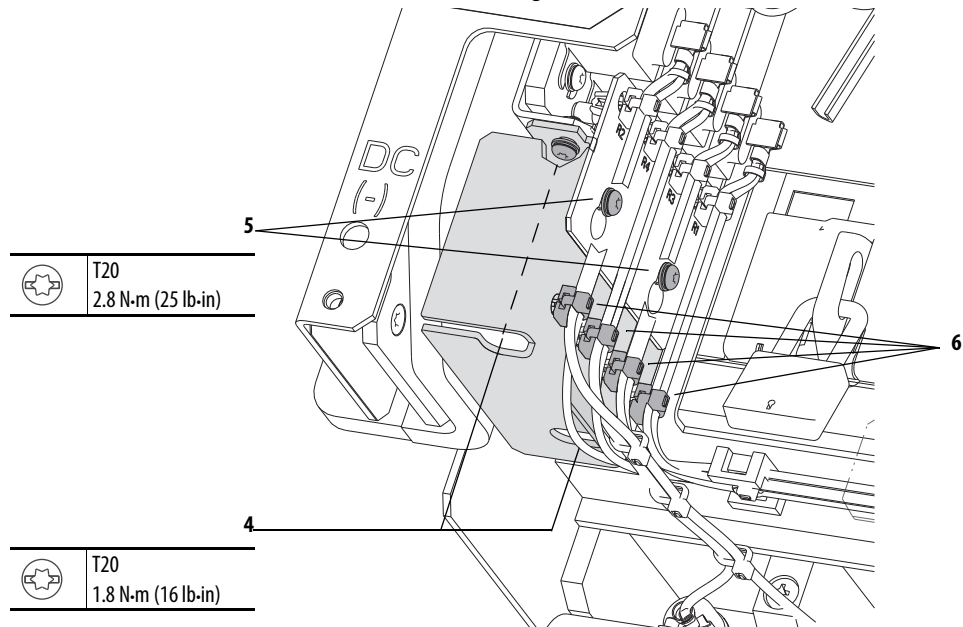



## Install the Rotary Disconnect Handle and New DC Precharge Cover

1. Secure the existing rotary on/off disconnect handle to the new DC precharge assembly left front cover by using the two M4 x 8 mm long screws and washers.

See [step 3](#) of Remove the DC Precharge Left-front Cover and Disconnect Switch Handle and Handle Shaft on page [5](#) for recommended torque.

2. Secure the two clear plastic guards to the new DC precharge assembly left front cover by using the four existing M5 x 14 mm screws.

See [step 2](#) of Remove the DC Precharge Left-front Cover and Disconnect Switch Handle and Handle Shaft on page [5](#) for recommended torque.

3. Set the rotary on/off handle and the disconnect handle shaft to the “off” position.

The disconnect handle shaft is in the “off” position when the pins on the end of the shaft are oriented horizontally.

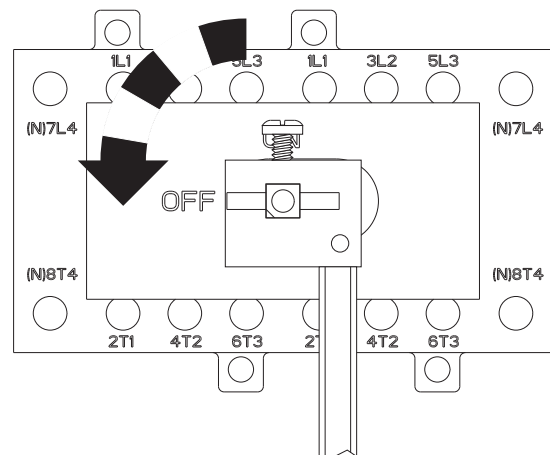
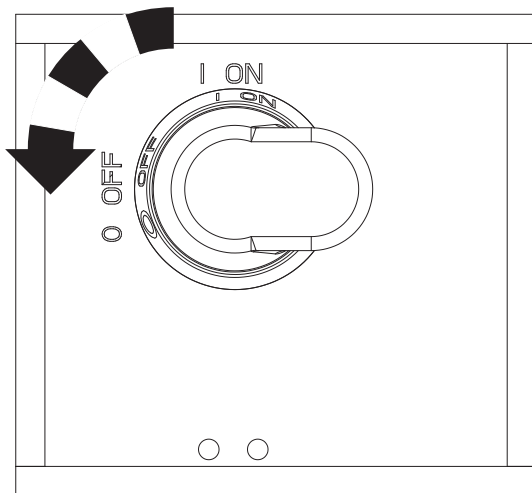

4. Align the rotary disconnect handle and shaft and place the new front cover on the DC precharge unit.
5. Secure the front cover by using the existing screws.

See [step 2](#) of Remove the DC Precharge Left-front Cover and Disconnect Switch Handle and Handle Shaft on page [5](#) for recommended torque.

## Install the Interlock Bracket

1. Loosen the two hexalobular screws that secure the circuit-breaker access door to the left front cover and lower the door.

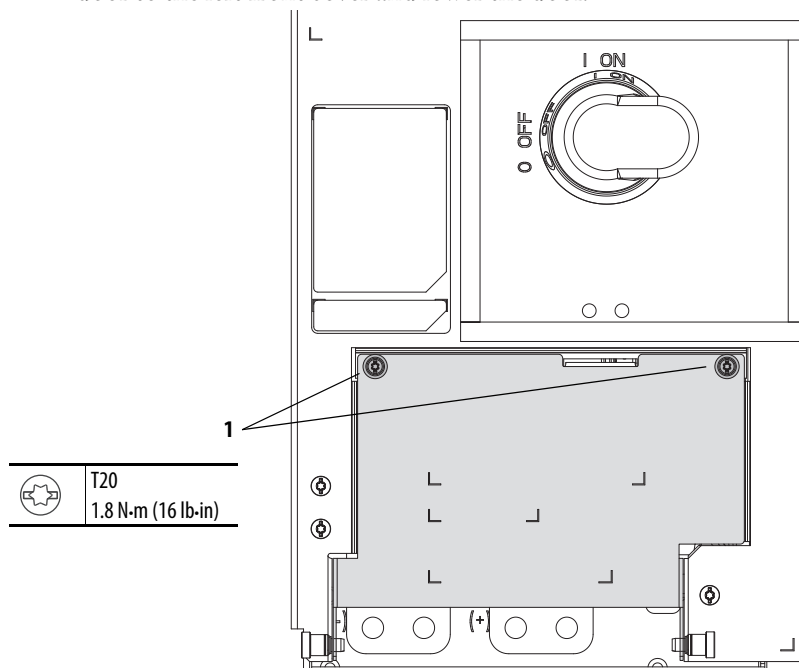

2. Position the L-bracket with the square opening on top and the screw holes to the front and flush with the back of the cover.

**IMPORTANT** The interlock rod behind the cover must fit into the square opening on the top of the L-bracket (as shown in the illustration).

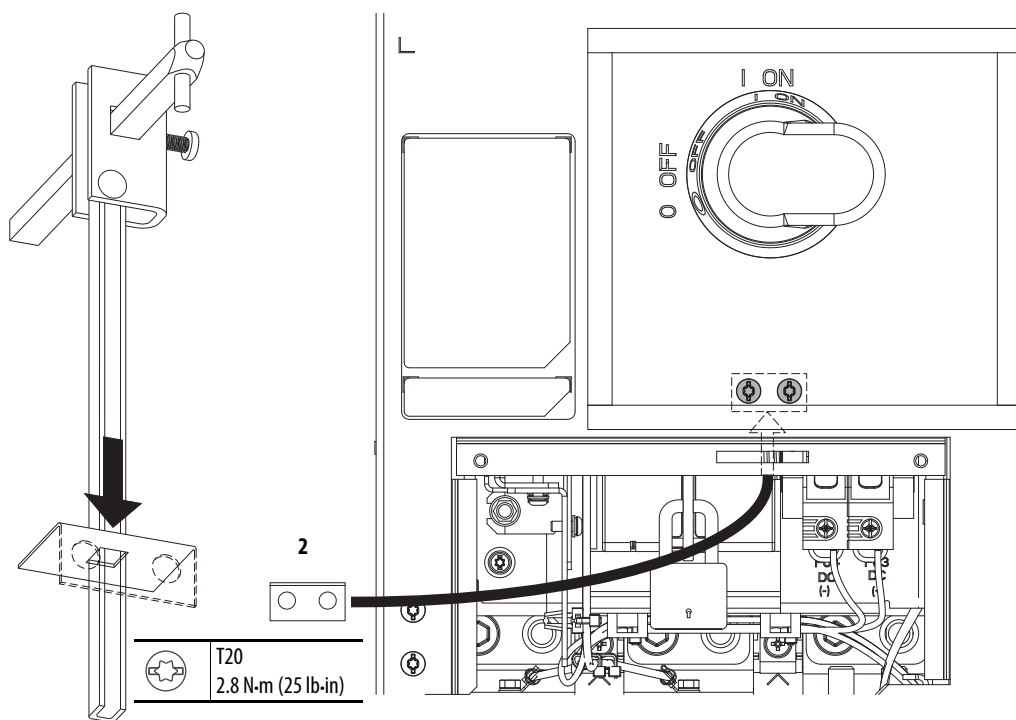

3. Secure the L-bracket by using the two M5 x 14 mm hexalobular screws that are provided in the kit.
4. Close and secure the circuit-breaker access door.
5. Move the disconnect handle to the “ON” position.
6. Verify that the circuit- breaker access door cannot be opened.
7. Secure the circuit-breaker access door by tightening the two hexalobular screws.

## Additional Resources

These documents contain additional information concerning related products from Rockwell Automation.

Resource	Description
PowerFlex® 750-Series AC Drives, Frame 8 and Larger Hardware Service Manual, publication <a href="#">750-TG001</a>	Provides a recommended preventative maintenance schedule, major component test and hardware replacement procedures, and schematic diagrams for frame 8 and larger PowerFlex 750-Series AC drives.
Product Certifications website, <a href="http://www.ab.com">http://www.ab.com</a>	Provides declarations of conformity, certificates, and other certification details.

You can view or download publications at <http://www.rockwellautomation.com/literature/>. To order paper copies of technical documentation, contact your local Allen-Bradley distributor or Rockwell Automation sales representative.

## Rockwell Automation Support

Rockwell Automation provides technical information on the Web to assist you in using its products.

At <http://www.rockwellautomation.com/support> you can find technical and application notes, sample code, and links to software service packs. You can also visit our Support Center at <https://rockwellautomation.custhelp.com/> for software updates, support chats and forums, technical information, FAQs, and to sign up for product notification updates.

In addition, we offer multiple support programs for installation, configuration, and troubleshooting. For more information, contact your local distributor or Rockwell Automation representative, or visit <http://www.rockwellautomation.com/services/online-phone>.

## Installation Assistance

If you experience a problem within the first 24 hours of installation, review the information that is contained in this manual. You can contact Customer Support for initial help in getting your product up and running.

United States or Canada	1.440.646.3434
Outside United States or Canada	Use the <a href="#">Worldwide Locator</a> at <a href="http://www.rockwellautomation.com/rockwellautomation/support/overview.page">http://www.rockwellautomation.com/rockwellautomation/support/overview.page</a> , or contact your local Rockwell Automation representative.

## New Product Satisfaction Return

Rockwell Automation tests all of its products to help ensure that they are fully operational when shipped from the manufacturing facility. However, if your product is not functioning and needs to be returned, follow these procedures.

United States	Contact your distributor. You must provide a Customer Support case number (call the phone number above to obtain one) to your distributor to complete the return process.
Outside United States	Please contact your local Rockwell Automation representative for the return procedure.

## Documentation Feedback

Your comments will help us serve your documentation needs better. If you have any suggestions on how to improve this document, complete this form, publication [RA-DU002](#), available at <http://www.rockwellautomation.com/literature/>.

U.S. Allen-Bradley Drives Technical Support - Tel: (1) 262.512.8176, Fax: (1) 262.512.2222, E-mail: [support@drives.ra.rockwell.com](mailto:support@drives.ra.rockwell.com)  
Online: [www.ab.com/support/abdrives](http://www.ab.com/support/abdrives).

Rockwell Automation maintains current product environmental information on its website at <http://www.rockwellautomation.com/rockwellautomation/about-us/sustainability-ethics/product-environmental-compliance.page>.

Allen-Bradley, PowerFlex, Rockwell Software, and Rockwell Automation are trademarks of Rockwell Automation, Inc.  
Trademarks not belonging to Rockwell Automation are property of their respective companies.

Rockwell Otomasyon Ticaret A.Ş., Kar Plaza İş Merkezi E Blok Kat:6 34752 İçerenköy, İstanbul, Tel: +90 (216) 5698400

**[www.rockwellautomation.com](http://www.rockwellautomation.com)**

### Power, Control and Information Solutions Headquarters

Americas: Rockwell Automation, 1201 South Second Street, Milwaukee, WI 53204-2496 USA, Tel: (1) 414.382.2000, Fax: (1) 414.382.4444  
Europe/Middle East/Africa: Rockwell Automation NV, Pegasus Park, De Kleetlaan 12a, 1831 Diegem, Belgium, Tel: (32) 2 663 0600, Fax: (32) 2 663 0640  
Asia Pacific: Rockwell Automation, Level 14, Core F, Cyberport 3, 100 Cyberport Road, Hong Kong, Tel: (852) 2887 4788, Fax: (852) 2508 1846