

# Installation Instructions

Original Instructions



**Allen-Bradley**  
by ROCKWELL AUTOMATION



## Sliding Bolt Actuator

Catalog Number 440G-A27163

Installation must be in accordance with the following steps and implemented by suitably competent personnel. This device is intended to be part of the safety-related control system of a machine.

Before installation, perform a risk assessment to determine whether the specifications of this device are suitable for all operational and environmental characteristics of the machine to which it is to be fitted.

At regular intervals during the life of the unit, check whether these characteristics remain valid and inspect this device for evidence of accelerated wear, material degradation, or tampering. If necessary, replace the device. The manufacturer cannot accept responsibility for a failure of this device if the procedures are not implemented or if it is used outside the recommended specifications in this document.

The actuator is not to be used as a mechanical stop. Guard stops and guides must be fitted.

Exposure to shock and/or vibration in excess of those stated in IEC 68 part: 2-6/7 should be prevented.

Adherence to the recommended maintenance instructions forms part of the warranty.



**ATTENTION:** Do not defeat, tamper, remove, or bypass this unit. Severe injury to personnel could result.

## Summary of Changes

This publication contains the following new or updated information. This list includes substantive updates only and is not intended to reflect all changes.

Topic	Page
Updated Specifications table.	1
Added screw torque to Installation section.	1
Added 440T Prosafe Slamlock measurements to <a href="#">Figure 2</a> .	1
Updated <a href="#">Figure 3</a> .	2

## Product Overview

The 440G sliding bolt actuator is a manually operated, sliding actuator for use with Guardmaster® Trojan™ 5, Trojan 5 GD2, 440G-MT, TLS-GD2, and Prosafe® Slamlock™ interlock switches. When in a suitable application, the actuator can be extended to operate an interlock switch or when fully retracted can be locked off with 1...3 padlocks.

## Specifications

Attribute	440G-A27163
Material	Housing: Aluminum Actuator/handle: Stainless steel/mild steel
Weight, approximate	580 g (1.25 lb)
Color	Self-colored
Mechanical life	1 x 10 <sup>6</sup>
Mounting screws	4 x M5 10 mm (0.39 in.) deep tapped holes

## Installation

Use M5 screws and torque to 5 N•m (3.69 lb•ft).

Figure 1 - Mounting

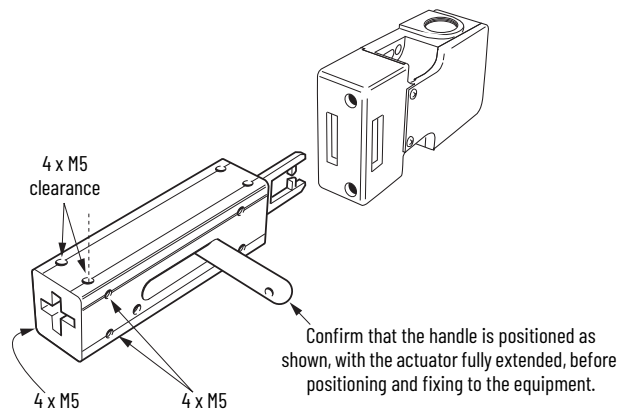
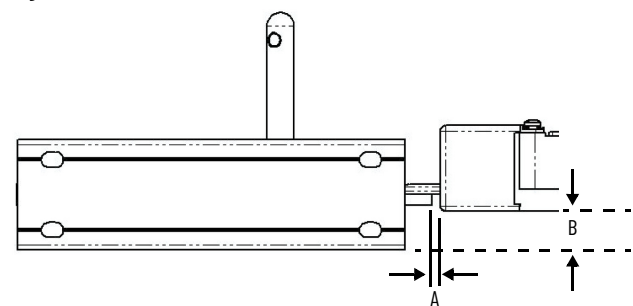
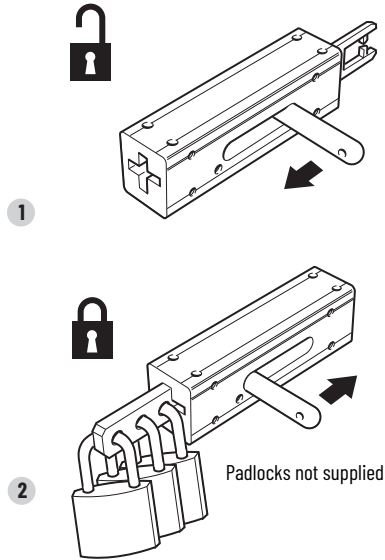

Figure 2 - Insertion and Offset



Item	Description	Distance [mm (in.)]
A	Actuator insertion distance	<ul style="list-style-type: none"> <li>Trojan 5: 7...9 (0.28...0.35)</li> <li>Trojan 5 GD2: 1...3 (0.04...0.12)</li> <li>TLS GD2: 1...3 (0.04...0.12)</li> <li>440G-MT: 0...2 (0...0.08)</li> <li>440T Prosafe Slamlock: 1...4 (0.04...0.16)</li> </ul>
B	Offset	<ul style="list-style-type: none"> <li>TLS GD2: 14.55 (0.57)</li> <li>440G-MT: 10.85 (0.43)</li> <li>440T Prosafe Slamlock: 14.55 (0.57)</li> </ul>

## Operation



## Approximate Dimensions

Figure 3 - Sliding Bolt Actuator Dimensions [mm (in.)]

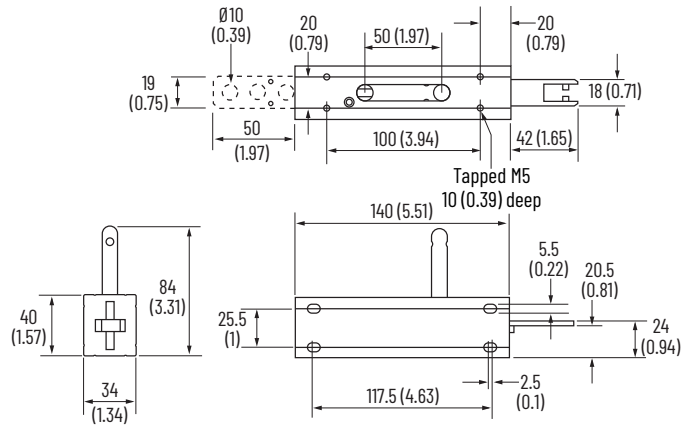

## Maintenance

Check alignment of actuator to switch. Also check for signs of abuse or damage and replace if apparent. Verify that the actuator is firmly fixed in position and operates smoothly.

## Repair

If there is any malfunction or damage, no attempts at repair should be made. The unit should be replaced before machine operation is allowed.

**IMPORTANT** Do not dismantle the unit.

## Waste Electrical and Electronic Equipment (WEEE)







At the end of life, this equipment should be collected separately from any unsorted municipal waste.

Rockwell Automation maintains current product environmental compliance information on its website at [rok.auto/pec](http://rok.auto/pec).

Your comments help us serve your documentation needs better. If you have any suggestions on how to improve our content, complete the form at [rok.auto/docfeedback](http://rok.auto/docfeedback).

For technical support, visit [rok.auto/support](http://rok.auto/support).

Rockwell Otomasyon Ticaret A.Ş. Kar Plaza İş Merkezi E Blok Kat:6 34752, İçerenköy, İstanbul, Tel: +90 (216) 5698400 EEE Yönetmeliğine Uygundur

Connect with us.    

[rockwellautomation.com](http://rockwellautomation.com) — expanding human possibility®

AMERICAS: Rockwell Automation, 1201 South Second Street, Milwaukee, WI 53204-2496 USA, Tel: (1) 414.382.2000, Fax: (1) 414.382.4444

EUROPE/MIDDLE EAST/AFRICA: Rockwell Automation NV, Pegasus Park, De Kleetlaan 12a, 1831 Diegem, Belgium, Tel: (32) 2 663 0600, Fax: (32) 2 663 0640

ASIA PACIFIC: Rockwell Automation, Level 14, Core F, Cyberport 3, 100 Cyberport Road, Hong Kong, Tel: (852) 2887 4788, Fax: (852) 2508 1846

Allen-Bradley, expanding human possibility, Guardmaster, Prosafe, Rockwell Automation, Slamlock, and Trojan are trademarks of Rockwell Automation, Inc. Trademarks not belonging to Rockwell Automation are property of their respective companies.

Publication 440G-IN020A-EN-P - August 2021 | Supersedes Publication ACTUAT-IN002B-EN-P - October 2005  
Copyright © 2021 Rockwell Automation, Inc. All rights reserved. Printed in the U.S.A.



77563

77563 Ver 06