

## 440G-MZ Guardmaster Safety Switches

Catalog Numbers 440G-MZS20SNRJ, 440G-MZS20UNRJ, 440G-MZS20SNLJ, 440G-MZS20UNLJ



**ATTENTION:** Read this document and the documents that are listed in [Additional Resources on page 5](#) about installation, configuration, and operation of this equipment before you install, configure, operate, or maintain this product. Users are required to familiarize themselves with installation and wiring instructions, and requirements of all applicable codes, laws, and standards. Only suitably trained personnel must perform activities including installation, adjustments, commissioning, use, assembly, disassembly, and maintenance in accordance with applicable code of practice. If this equipment is used in a manner that the manufacturer does not specify, the protection that is provided by the equipment may be impaired.

Topic	Page
Introduction	1
Installation	2
Commissioning – Unique Coded Models	2
Auxiliary Release	3
Approximate Dimensions	3
Pin Assignment	4
Connection in a GuardLink System	4
Specifications	4
Status Indicators	5
Lock Command	5
Catalog Number Explanation	5
Accessories	5
Additional Resources	5

### Introduction



**ATTENTION:** Do not attempt to install this device unless the installation instructions have been studied and understood. This document acts as a guide for a typical installation and is available in some languages at [rok.auto/literature](http://rok.auto/literature). A user manual is also available (see [Additional Resources on page 5](#)).

**Figure 1 - Assembly Overview**

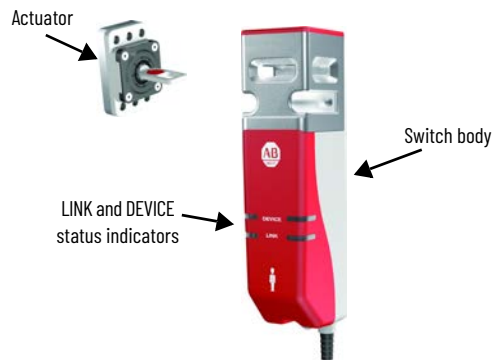

The 440G-MZ Guardmaster® Guard Locking Switch locks a guard door in the closed position and does not release it until the hazardous machine functions that are covered by the guard are in a safe condition. The safety control system only allows the hazardous machine functions to operate when the guard is closed and locked.

Qualified personnel must install the switch in accordance with these instructions.



**ATTENTION:** This device is intended to be part of the safety-related control system of a machine. Before installation, a risk assessment must be performed to determine whether the specifications of this device are suitable for all foreseeable operational and environmental characteristics of the application. See [Specifications on page 4](#) for certification information and ratings.

Use appropriate screws, bolts, or nuts that are fitted with tools to mount the switch and actuators to avoid the risk of tampering. Do not over torque the mounting hardware.

## Installation



**ATTENTION:** Do not defeat, tamper, remove, or bypass this unit. Severe injury to personnel could result. The presence of spare actuators can compromise the integrity of the safety systems. Personal injury or death, property damage, or economic loss can result. Appropriate management controls, working procedures, and alternative protective measures should be introduced to control their use and availability.

**Figure 2 - Required Mounting Hardware for Switch and Actuator**



### IMPORTANT

Washers are not required and if used can cause the mounting holes on the switch body to crack. If standard thread locking compound is used on the mounting screws of the switch body, check the manufacturer's specification. Many standard thread-locking compounds can attack the plastic feet of the switch body, which can cause stress cracks. It is recommended to use cyanoacrylate-type thread-locking compounds.

**Figure 3 - Actuator Function**

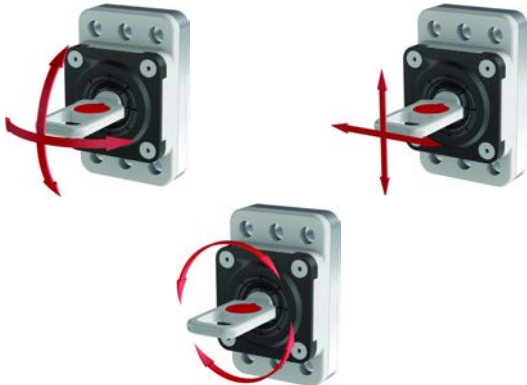

The flexible actuator bends, rotates, and slides to accommodate guard door misalignment (Figure 3). For optimal performance, verify that the locking bolt can enter and withdraw from the tongue actuator without binding. A separately mounted door latch is recommended to avoid door misalignment.

**Figure 4 - Orientation of Assembled Switch**



## Minimum Distance Between Switches

If a pair of 440G-MZ safety switches are mounted too close to one another, the two magnetic fields interact causing crosstalk, which results in nuisance faults and false operation.

A minimum of 100 mm (3.94 in.) must separate a pair of switches to help achieve correct operation.

This restriction applies to any pair of Guardmaster safety switches that use RFID sensing technology, including 440N-Z SensaGuard™ interlocks, or TLS-Z and 440G-LZ guard locking switches.

**Figure 5 - Minimum Distance between Switches [mm (in.)]**

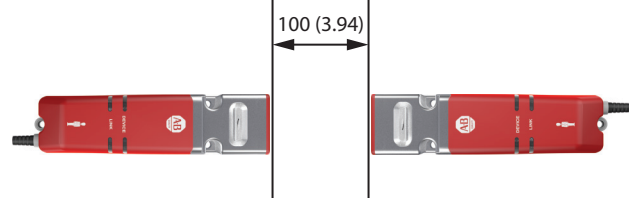

**Figure 6 - Three Directions of Approach**



## Commissioning – Unique Coded Models

The actuator teach process is not performed at the factory and must be performed when the switch is first put into use. After the first-time learn, this process can be repeated up to seven more times with unique coded replacement actuators.

During commissioning, connect the switch as shown in Figure 7.

**Figure 7 - Wiring**

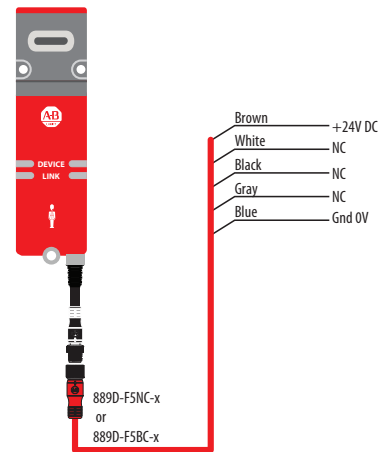

## First Time Learn

Apply power to the switch without the actuator present. After the switch completes the power sequence (approximately 8 seconds), the status indicator flashes green eight times, which indicates the total number of times a new actuator can be learned. This status indicator sequence repeats until an actuator is inserted in the switch (in the guard closed position).

Table 1 - Commissioning Process for Unique Coded Switches

Step	State	Approximate Duration	LED Indicators
1	Actuator Present	15 s	<ul style="list-style-type: none"> <li>Flashing 8x green, repeating <sup>(1)</sup></li> <li>Solid red (learning a replacement actuator)</li> </ul>
2	Verifying Actuator	15 s	Flashing red/green, slow
3	Programming Switch	15 s	Flashing red/green, fast
4	Program Finalization	15 s	Flashing green (number of times a new actuator can be learned)
5	Run Mode <sup>(2)</sup>	—	Solid red

(1) Out of box condition only.

(2) When teaching an actuator, the switch must be unlocked to insert the actuator. At the completing program finalization, the switch remains unlocked and in the safe state.

**IMPORTANT** After teaching a new actuator, a power cycle is required to complete the process.

## Learn Additional Replacement Actuators

The switch automatically starts a new teach process (Table 1) when a unique coded replacement actuator is inserted in the switch (in the guard closed position).

**IMPORTANT** When the switch learns a new actuator, it no longer recognizes previously learned actuators.

## Lock the Actuator Code

If the actuator is removed from the switch and then reinserted into the switch during the 15-second Program Finalization stage (see Step 4 in Table 1), this action triggers the switch to LOCK the actuator code. This action can be performed during any of the eight unique coded actuator learn cycles.

**IMPORTANT** After a unique coded actuator is locked using this method, the switch cannot learn additional replacement actuators for the remaining life of the switch. If the actuator is lost or damaged, the switch must be replaced.

## Error Codes

The following indicator patterns repeat until a Power Off/On cycle is completed.

Status/Diagnostic Indicator	Error Code
Red-red-red-green	Cannot learn a standard actuator
Red-red-red-green-green	Actuator already learned
Red-red-red-green-green-green	Bad RFID; actuator moved out of range
Red-red-red-green-green-green-green	Exceeded learning eight actuators
Red-red-red-green-green-green-green-green	Unit locked: cannot learn another actuator

## Auxiliary Release

Operation of the auxiliary release causes a fault condition.

To reset the switch, cycle the power or issue a RESET command over the link in a GuardLink® safety system.

Figure 8 - Auxiliary Release Operation [mm (in.)]

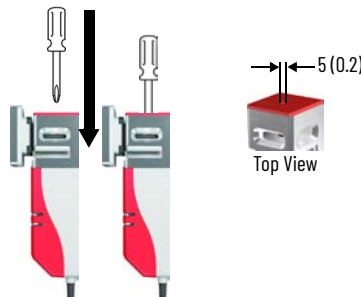

## Approximate Dimensions

Figure 9 - Switch Body [mm (in.)]

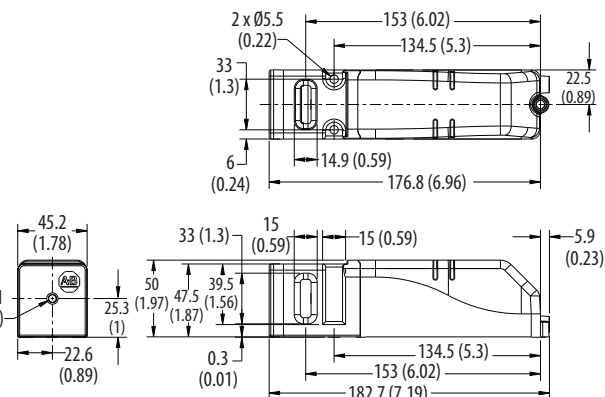
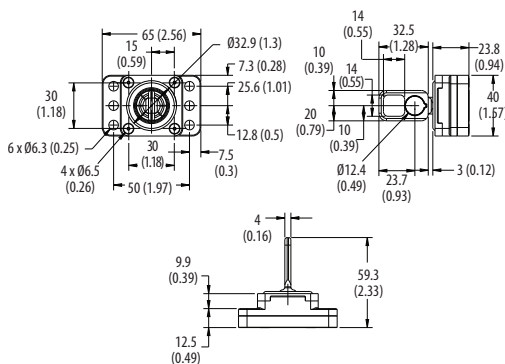

Figure 10 - Actuator [mm (in.)]



## Pin Assignment

Table 2 - 5-pin Micro (M12) <sup>(1)</sup>



Pin	Color	Function	
		OSSD Mode	GuardLink Mode
1	Brown	+24V	+24V
2	White	Safety A	Safety In
3	Blue	0V	0V
4	Black	Safety B	Safety Out
5	Gray	Lock Command	Command, Lock, and Unlock (CLU)

(1) The recommended cordset is catalog number 889D-F5AC-2 (2 m [6.5 ft]). For additional lengths, replace the 2 with 5 [5 m (16.4 ft)] or 10 [10 m (32.8 ft)] for standard cable lengths. The recommended patchcord for use with ArmorBlock® Guard Safety I/O is the 2 m (6.5 ft) catalog number 889D-F5ACDM-2. Replace the 2 with 0M3 [0.98 ft], 1 [1 m (3.28 ft)], 5 [5 m (16.4 ft)], or 10 [10 m (32.8 ft)] for standard cable lengths.

## Connection in a GuardLink System

The 440G-MZ safety switch can be connected to a GuardLink system via a passive tap (catalog number 440S-PF5D shown in Figure 11) or a passive power tap (catalog number 440S-PF5D4).

Figure 11 - Connect 440G-MZ Switch to a GuardLink System with a Passive Tap

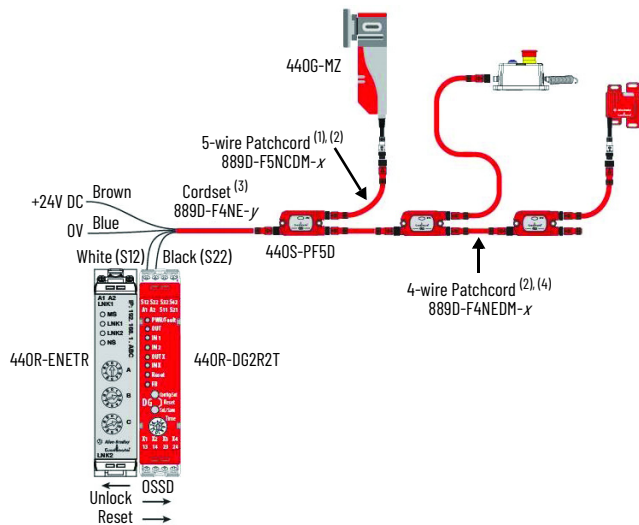

- 10 m (32.8 ft) length, max.
- Replace *x* with 0M3 (300 mm [0.98 ft]), 0M6 (600 mm [1.97 ft]), 1 (1 m [3.3 ft]), 2 (2 m [6.6 ft]), 5 (5 m [16.4 ft]), or 10 (10 m [32.8 ft]) for standard cable lengths.
- Replace *y* in order number with 2 (2 m [6.6 ft]), 5 (5 m [16.4 ft]), 10 (10 m [32.8 ft]), 15 (15 m [49.2 ft]), 20 (20 m [65.6 ft]), or 30 (30 m [98.4 ft]) for standard cable lengths.
- 30 m (98.4 ft) length, max

## Specifications

Attribute	Value
Standards	IEC 60947-5-3, IEC 61508, ISO 13849-1, IEC 62061, ISO 14119, UL 508
Safety classification	Type 4 interlocking device with guard locking per ISO 14119 with low (standard) and high (unique) coding per ISO 14119 Suitable for use in applications up to and including PLe Cat 4 per ISO 13849-1, SIL CL 3 per IEC 62061, and SIL 3 per IEC 61508.
Functional safety data	See publication <a href="#">SAFETY-SR001</a>
Certifications	CE Marked for all applicable EU directives, c-UL-us, TÜV
<b>Operating Characteristics</b>	
Torque for M5 mounting of switch and actuator mounting bracket	2 N•m (17.7 lb•in) max
Locking bolt alignment tolerance X, Y, Z	±5 mm (0.2 in.) max
Holding force $F_{max}$ (ISO 14119)	3250 N
Holding force $F_{zh}$ (ISO 14119)	2500 N
Output current, max (each output)	200 mA
Quiescent power consumption, locked or unlocked	1.5 W
Lock signal current	1 mA
Peak current and duration, at turn on or after lock/unlock operation	150 mA for approximately 800 ms following lock/unlock operation.
Steady state current, max	OSSD mode: 40 mA GL mode: 50 mA
Operating voltage $U_e$	24V DC +10% / -15% Class 2 PELV
Operating cycle frequency, max	0.2 Hz
Dwell time between subsequent locking/unlocking	2.5 s
Response time (Off) (IEC 60947-5-3)	275 ms
Start up time (availability)	8 s
Utilization category (IEC 60947-5-2)	DC-13 24V 200 mA
Insulation voltage $U_i$ (IEC 60947-5-1)	75V
Impulse withstand voltage $U_{imp}$ (IEC 60947-5-1)	1 kV
Pollution degree (IEC 60947-5-1)	3
Auxiliary release	Built in
Protection class (IEC 61140)	Class II
Mechanical life	500,000 cycles
<b>Outputs (Guard door is closed and locked)</b>	
Safety outputs	2 x PNP, 0.2 A max / ON (+24V DC)
<b>Environmental</b>	
Operating temperature	0...55 °C (32...131 °F)
Storage temperature	-25...+75 °C (-13...+167 °F)
Operating humidity	5...95%, noncondensing
Enclosure ingress rating	IP65, IP66, IP67, IP69K
Shock and vibration	IEC 60068-2-27, 30 g (1.1 oz), 11 ms/IEC 60068-2-6, 10...55 Hz, 1 mm (0.4 in.)
Radio frequency/EMC	IEC 60947-5-3, FCC-1 (Parts 18 and 15), RED
<b>General</b>	
Materials	<ul style="list-style-type: none"> <li>Switch: Housing - ABS, front brace - SS304 (machined), SS316 (cast)</li> <li>Actuator: Housing and housing cover - SS304, spring - SS302, grommet - nitrile rubber, screws - stainless steel, tongue - SS410</li> <li>Brackets: High Strength Low Alloy Steel</li> <li>Padlock Accessory: SS410</li> </ul>
Weight	<ul style="list-style-type: none"> <li>Switch: 0.75 kg (1.7 lb)</li> <li>Actuator: 0.27 kg (0.6 lb)</li> <li>Actuator L mounting bracket: 0.27 kg (0.6 lb)</li> <li>Actuator Z bracket: 0.54 kg (1.2 lb)</li> <li>Switch L bracket: 1 kg (2.2 lb)</li> </ul>
Protection Type	Short-circuit, current limitation, overload, reverse polarity, overvoltage (up to 60V max), thermal shutdown/restart

## Status Indicators

Table 3 - Output Status and LED Indication

Guard Status	Lock Command	Lock Status	Device Indicator <sup>(1)</sup>	Output Status		State
				OSSD Mode (Safety A and B)	Guardlink Mode (Safety Out)	
Open or Closed	Unlock	Unlocked	Solid red	Off	Off	Safe
Open	Lock	Unlocked	Flashing amber	Off	Off	Ready. Close guard door to lock.
Closed	Lock	Locked	Solid green	On	On	Operational
Open or Closed	Lock or Unlock	Locked or Unlocked	Flashing red	Off	Off	Fault present. Cycle power or issue a RESET command over the link in a Guardlink system <sup>(2)</sup>

(1) The LINK status indicator is OFF in OSSD mode, and conditional on the status of other devices in Guardlink mode. See publication [440R-UM015](#) for information about the operation of a GuardLink safety system.

(2) See publication [440G-UM004](#) for additional information about Diagnostic and Fault Codes.

## Lock Command

Table 4 - Lock Command Function (OSSD mode)

Lock Type	OSSD Mode	Cat. No.
Power to Release	24V = Unlock 0V = Lock	440G-MZS20*NR*
Power to Lock	0V = Unlock 24V = Lock	440G-MZS20*NL*

**IMPORTANT** In Guardlink mode, LOCK and UNLOCK commands are sent via the GuardLink CLU signal. This function is the same for both Power to Release and Power to Lock models.





## Catalog Number Explanation

440G-MZS      20      S      N      R      J  
                          a      b      c      d      e

a		b		c	
Outputs (Safety/Auxiliary)		Actuator Code		Auxiliary Type	
Code	Description	Code	Description	Code	Description
20	Two safety/no aux	S	Standard code	N	No auxiliary
		U	Unique code		

d		e	
Lock Type		Connection Type	
Code	Description	Code	Description
R	Power to Release	J	M12 5-pin
L	Power to Lock		

## Accessories

Description			Catalog No.
Standard code actuator (Low level to EN ISO 14119)			440G-MZAS
Unique code actuator (High level to EN ISO 14119)			440G-MZAU
	Actuator mounting bracket	L-shaped	440G-MZAM1
		Z-shaped	440G-MZAM2
	Switch mounting bracket		440G-MZAM3
	Padlock accessory		440G-MZAL

## Additional Resources

These documents contain additional information concerning related products from Rockwell Automation.

Resource	Description
440G-MZ Guard Locking Switch User Manual, publication <a href="#">440G-UM004</a>	Provides general guidelines for installing a Rockwell Automation® guard locking switch.
Guardmaster DG Safety Relay and GuardLink System User Manual, publication <a href="#">440R-UM015</a>	Provides general guidelines for configuring a Rockwell Automation Guardlink safety system.
Industrial Automation Wiring and Grounding Guidelines, publication <a href="#">1770-4.1</a>	Provides general guidelines for installing a Rockwell Automation industrial system.
Product Certifications website: <a href="http://rok.auto/certifications">rok.auto/certifications</a>	Provides declarations of conformity, certificates, and other certification details.

You can view or download publications at [rok.auto/literature](http://rok.auto/literature).

## Waste Electrical and Electronic Equipment (WEEE)







At the end of life, this equipment should be collected separately from any unsorted municipal waste.

Rockwell Automation maintains current product environmental information on its website at [rok.auto/pec](http://rok.auto/pec).

Your comments help us serve your documentation needs better. If you have any suggestions on how to improve our content, complete the form at [rok.auto/docfeedback](http://rok.auto/docfeedback).  
For technical support, visit [rok.auto/support](http://rok.auto/support).

Rockwell Otomasyon Ticaret A.Ş. Kar Plaza İş Merkezi E Blok Kat:6 34752 İçerenköy, İstanbul, Tel: +90 (216) 5698400 EEE Yönetmeliğine Uygundur

Connect with us.    

[rockwellautomation.com](http://rockwellautomation.com)

expanding **human possibility**<sup>™</sup>

AMERICAS: Rockwell Automation, 1201 South Second Street, Milwaukee, WI 53204-2496 USA, Tel: (1) 414.382.2000, Fax: (1) 414.382.4444

EUROPE/MIDDLE EAST/AFRICA: Rockwell Automation NV, Pegasus Park, De Kleetlaan 12a, 1831 Diegem, Belgium, Tel: (32) 2 663 0600, Fax: (32) 2 663 0640

ASIA PACIFIC: Rockwell Automation, Level 14, Core F, Cyberport 3, 100 Cyberport Road, Hong Kong, Tel: (852) 2887 4788, Fax: (852) 2508 1846

Allen-Bradley, ArmorBlock, expanding human possibility, GuardLink, Guardmaster, Rockwell Automation, Rockwell Software, and SensaGuard are trademarks of Rockwell Automation, Inc.

Trademarks not belonging to Rockwell Automation are property of their respective companies.



PN-539600

Publication 440G-IN018B-EN-P - April 2020 | Supersedes Publication 440G-IN018A-EN-P-February 2020  
Copyright © 2020 Rockwell Automation, Inc. All rights reserved. Printed in the U.S.A.

PN-539600  
10005220453 Ver 01