



PowerFlex[®] 700L Frame 2 Common Mode Choke Kit

(Catalog Number SK-L1-CHK2-F2)

Where this Kit is Used

The SK-L1-CHK2-F2 Common Mode Choke Kit must be installed with PowerFlex 700L Frame 2 drives for CE compliance (EN 61800-3). When installed at the drive AC power input and drive motor output, the common mode choke kit helps to guard against interference with other electrical equipment (programmable controllers, sensors, analog circuits, etc.).

What This Kit Contains

Each Common Mode Choke Kit includes two Common Mode cores with integral mounting brackets for the input power cables and two clamps for the shielded motor cable.

Installation Guidelines

Each assembly should be mounted as close to the drive as possible while leaving sufficient distance between the assembly and the drive to provide clearance for cables and leads to be installed at the drive. Mounting dimensions for the choke assembly are provided at the back of this publication.

Mounting and Wiring

To install the choke assembly, follow these steps:



ATTENTION: To avoid an electric shock hazard, verify that the voltage on the bus capacitors has completely discharged before performing any work on the drive. After removing power to the drive, wait 5 minutes for the bus capacitors to discharge. Remove the cover of the drive. Measure the DC bus voltage at the DC+ TESTPOINT and DC- TESTPOINT sockets on the front of the drive beneath the drive cover. The voltage must be zero.

1. Turn off and lock out input power. Wait 5 minutes.

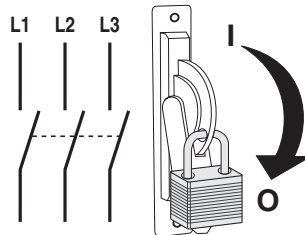

2. Verify that there is no voltage at the drive's AC input power terminals.

3. Remove the cover of the drive. Loosen the five (5) captive screws and pull the cover off the drive. Set the cover aside to be reinstalled later.
4. Measure the DC bus voltage at the DC+ TESTPOINT and DC- TESTPOINT sockets on the front of the power module chassis. The voltage must be zero.

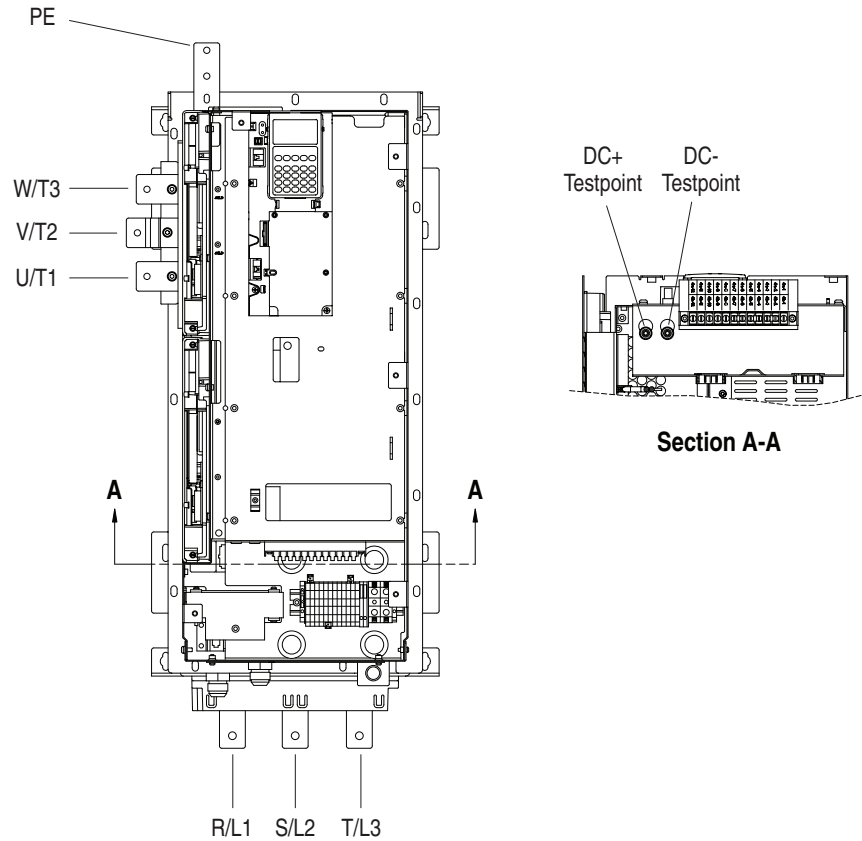

5. Mount the clamp assembly for the motor output on a metal surface near the top left of the drive using M8 hardware. Leave sufficient clearance between the clamp assembly and the drive terminals to allow access to the terminals and provide proper bend radius for the leads.
6. Terminate the motor leads at the U/T1, V/T2, and W/T3 connections on the motor as shown in [Figure 1](#). A properly sized ground conductor from the motor frame is also required. The ground conductor is routed around (not through) the clamp assembly and connected to the drive's PE earth ground terminal.
7. Remove the motor cable insulation and fold back the shield over the cable insulation. Clamp the shield and cable into the assembly ([Figure 2](#)). Terminate at the drive's U/T1, V/T2, and W/T3 terminals. **Note:** When using a second motor cable, use the additional clamp provided.

Figure 1 Power Wiring Connections Through Choke Assemblies to the Drive

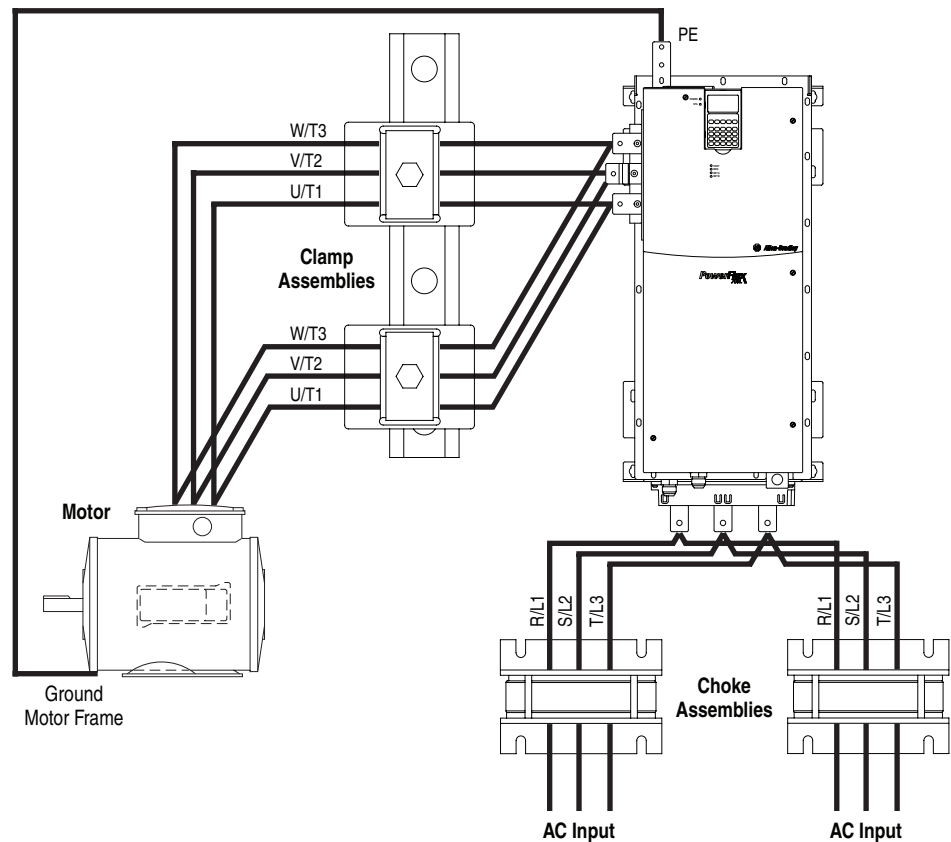
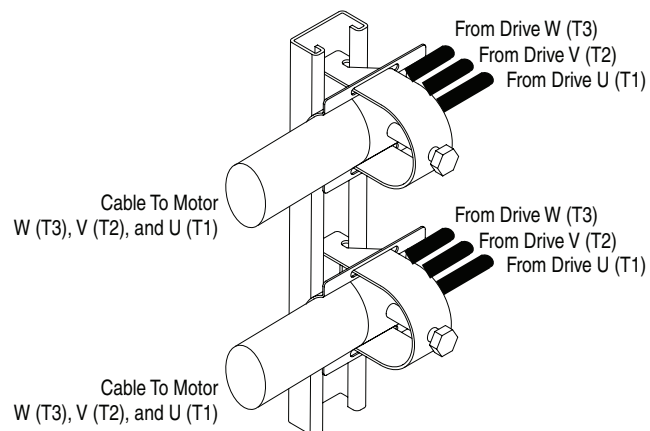
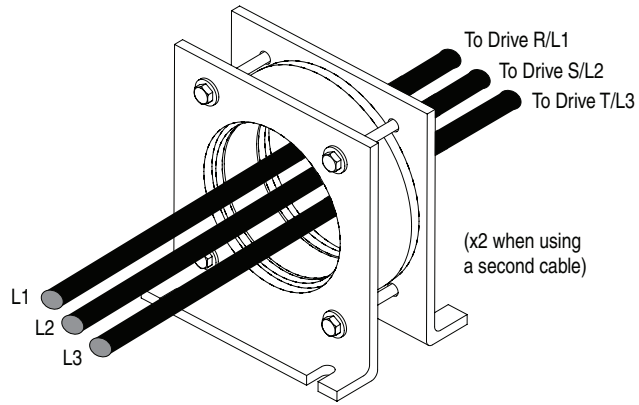

Figure 2 Motor Output Power Leads through Clamp Assembly



8. Mount the choke assembly for the AC input power to the drive on a metal surface near the bottom of the drive using M8 hardware. Leave sufficient clearance between the choke assembly and the drive terminals to allow access to the terminals and provide proper bend radius for the leads.
9. Run the AC input power leads to the drive straight through the choke assembly ([Figure 3](#)) and terminate at the R/L1, S/L2, and T/L3 drive terminals. **Note:** When using two cables for each phase, pass each cable through a choke assembly.

Figure 3 AC Input Power Leads through Choke Assembly



10. Replace the drive cover.

Choke Assembly Mounting Dimensions

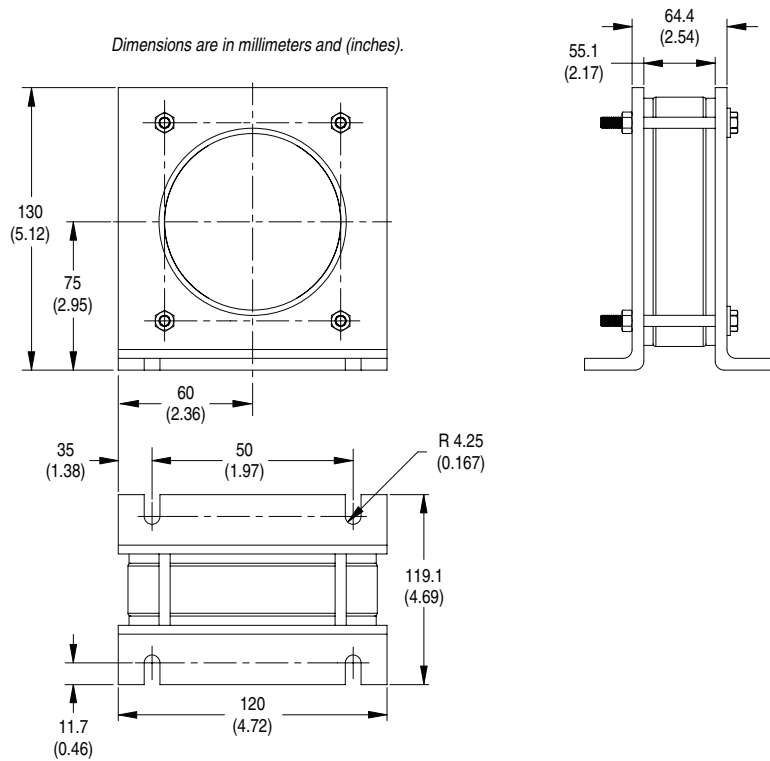

U.S. Allen-Bradley Drives Technical Support - Tel: (1) 262.512.8176, Fax: (1) 262.512.2222, Email: support@drives.ra.rockwell.com, Online: www.ab.com/support/abdrives

www.rockwellautomation.com

Power, Control and Information Solutions Headquarters

Americas: Rockwell Automation, 1201 South Second Street, Milwaukee, WI 53204-2496 USA, Tel: (1) 414.382.2000, Fax: (1) 414.382.4444

Europe/Middle East/Africa: Rockwell Automation, Vorstlaan/Boulevard du Souverain 36, 1170 Brussels, Belgium, Tel: (32) 2 663 0600, Fax: (32) 2 663 0640

Asia Pacific: Rockwell Automation, Level 14, Core F, Cyberport 3, 100 Cyberport Road, Hong Kong, Tel: (852) 2887 4788, Fax: (852) 2508 1846