

Kinetix 300 EtherNet/IP Indexing Servo Drives

Catalog Numbers 2097-V31PRO, 2097-V31PR2, 2097-V32PRO, 2097-V32PR2, 2097-V32PR4, 2097-V33PR1, 2097-V33PR3, 2097-V33PR5, 2097-V33PR6, 2097-V34PR3, 2097-V34PR5, 2097-V34PR6

| Topic | Page |
|--------------------------------|------|
| About the Kinetix 300 Drives | 1 |
| Important User Information | 2 |
| Catalog Number Explanation | 3 |
| Before You Begin | 4 |
| Safety Information | 4 |
| Install the Kinetix 300 Drive | 5 |
| Connector Data | 7 |
| Power Wiring Requirements | 12 |
| Motor Overload Protection | 15 |
| Circuit Breaker/Fuse Selection | 16 |
| Additional Resources | 19 |

About the Kinetix 300 Drives

Kinetix® 300 EtherNet/IP indexing servo drives provide an Ethernet-enabled solution for applications with output power requirements in the range of 0.4...3.0 kW (2...12 A rms).

See the Kinetix 300 EtherNet/IP Indexing Servo Drives User Manual, publication [2097-UM001](#), for detailed information on how to wire, apply power, troubleshoot, and integrate with ControlLogix®, CompactLogix™, or MicroLogix™ controller platforms.

Important User Information

Read this document and the documents listed in the additional resources section about installation, configuration, and operation of this equipment before you install, configure, operate, or maintain this product. Users are required to familiarize themselves with installation and wiring instructions in addition to requirements of all applicable codes, laws, and standards.

Activities including installation, adjustments, putting into service, use, assembly, disassembly, and maintenance are required to be carried out by suitably trained personnel in accordance with applicable code of practice.

If this equipment is used in a manner not specified by the manufacturer, the protection provided by the equipment may be impaired.

In no event will Rockwell Automation, Inc. be responsible or liable for indirect or consequential damages resulting from the use or application of this equipment.

The examples and diagrams in this manual are included solely for illustrative purposes. Because of the many variables and requirements associated with any particular installation, Rockwell Automation, Inc. cannot assume responsibility or liability for actual use based on the examples and diagrams.

No patent liability is assumed by Rockwell Automation, Inc. with respect to use of information, circuits, equipment, or software described in this manual.

Reproduction of the contents of this manual, in whole or in part, without written permission of Rockwell Automation, Inc., is prohibited.

Throughout this manual, when necessary, we use notes to make you aware of safety considerations.



WARNING: Identifies information about practices or circumstances that can cause an explosion in a hazardous environment, which may lead to personal injury or death, property damage, or economic loss.



ATTENTION: Identifies information about practices or circumstances that can lead to personal injury or death, property damage, or economic loss. Attentions help you identify a hazard, avoid a hazard, and recognize the consequence.

IMPORTANT Identifies information that is critical for successful application and understanding of the product.

Labels may also be on or inside the equipment to provide specific precautions.



SHOCK HAZARD: Labels may be on or inside the equipment, for example, a drive or motor, to alert people that dangerous voltage may be present.



BURN HAZARD: Labels may be on or inside the equipment, for example, a drive or motor, to alert people that surfaces may reach dangerous temperatures.



ARC FLASH HAZARD: Labels may be on or inside the equipment, for example, a motor control center, to alert people to potential Arc Flash. Arc Flash will cause severe injury or death. Wear proper Personal Protective Equipment (PPE). Follow ALL Regulatory requirements for safe work practices and for Personal Protective Equipment (PPE).

Catalog Number Explanation

This publication applies to the following Kinetix 300 drives.

Kinetix 300 Drives (single-phase)

| Cat. No. | Input Voltage | Continuous Output Current A (0-pk) | Features |
|-------------|---------------|------------------------------------|--|
| 2097-V31PRO | 120/240V, 1 Ø | 2.8 | <ul style="list-style-type: none"> 120V Doubler mode Safe torque-off |
| 2097-V31PR2 | | 5.7 | |
| 2097-V32PRO | 240V, 1 Ø | 2.8 | <ul style="list-style-type: none"> Integrated AC line filter Safe torque-off |
| 2097-V32PR2 | | 5.7 | |
| 2097-V32PR4 | | 11.3 | |

Kinetix 300 Drives (single- or three-phase)

| Cat. No. | Input Voltage | Continuous Output Current A (0-pk) | Features |
|-------------|-------------------------------------|------------------------------------|-----------------|
| 2097-V33PR1 | 120V, 1 Ø 240V, 1 Ø 240V, 3 Ø | 2.8 | Safe torque-off |
| 2097-V33PR3 | | 5.7 | |
| 2097-V33PR5 | | 11.3 | |
| 2097-V33PR6 | | 17.0 | |

Kinetix 300 Drives (three-phase)

| Cat. No. | Input Voltage | Continuous Output Current A (0-pk) | Features |
|-------------|---------------|------------------------------------|-----------------|
| 2097-V34PR3 | 480V, 3 Ø | 2.8 | Safe torque-off |
| 2097-V34PR5 | | 5.7 | |
| 2097-V34PR6 | | 8.5 | |

Before You Begin

Remove all packing material, wedges, and braces from within and around the components. After unpacking, check the item nameplate catalog number against the purchase order.

Parts List

The Kinetix 300 drive ships with the following:

- General-purpose power input (IPD) header, back-up power (BP) header, shunt resistor, and DC bus (BC) header, motor power (MP) header, and safe torque-off (STO) header
- A ground clamp that also provides strain relief for motor power cable
- These installation instructions, publication [2097-IN001](#)

TIP The connector kit for motor feedback (catalog number 2090-K2CK-D15M) is not provided. Replacement connector sets (catalog number 2097-CONN1) are also available. See the Kinetix Motion Accessories Specifications Technical Data, publication [GMC-TD004](#), for more information.

Safety Information



SHOCK HAZARD: Capacitors retain charge for approximately 300 s after power is removed. Disconnect incoming power and wait at least five minutes before touching the drive. Failure to observe this precaution could result in severe bodily injury or loss of life.



RISQUE DE CHOC: Les condensateurs restent sous charge pendant environ 300 secondes après une coupure de courant. Couper l'alimentation et patienter pendant au moins 5 minutes avant de toucher l'entraînement. Le non-respect de cette précaution peut entraîner des blessures corporelles graves ou la mort.



WARNING: The opening of branch-circuit protective device can be an indication that a fault has been interrupted. To reduce the risk of fire or electric shock, parts that carry current and other components of the controller must be examined and replaced if damaged.



AVERTISSEMENT: Le déclenchement du dispositif de protection du circuit de dérivation peut être dû à une coupure qui résulte d'un courant de défaut. Pour limiter le risque d'incendie ou de choc électrique, examiner les pièces porteuses de courant et les autres éléments du contrôleur et les remplacer s'ils sont endommagés. En cas de grillage de l'élément traverse par le courant dans un relais de surcharge, le relais tout entier doit être remplacé.

Install the Kinetix 300 Drive

These procedures assume that you have prepared your panel, and understand how to bond your system. For installation instructions regarding equipment and accessories that are not included here, refer to the instructions that came with those products



SHOCK HAZARD: To avoid hazard of electrical shock, mount and wire the Kinetix 300 drive before you apply power. Once power is applied, connector terminals can have voltage present even when not in use.



ATTENTION: Plan the installation of your system so that you can cut, drill, tap, and weld with the system removed from the enclosure. Because the system is open-type construction, be careful to keep metal debris from falling into it. Metal debris or other foreign matter can become lodged in the circuitry and result in damage to components.

Mount the Kinetix 300 Drive

Follow these steps to mount the drive.

1. Observe these clearance requirements when mounting the drive to the panel.

IMPORTANT Mount the module in an upright position as shown. Do not mount the module on its side.

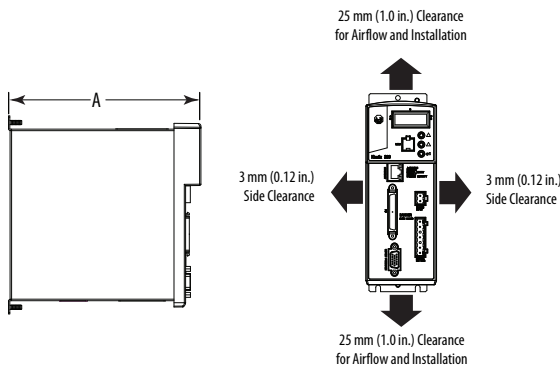

- Extra clearance and different hole patterns are required for side mount and rear mount AC line filters. See the table and step 2 for more details.
- More clearance is required depending on the other accessories installed.
- More clearance is required for the cable and wires that are connected to the top, front, and bottom of the drive.
- An extra 150 mm (6.0 in.) clearance is required when the drive is mounted next to noise sensitive equipment or clean wireways.

See page 6 for Kinetix 300 drive dimensions.

| Drive Cat. No. | A mm (in.) |
|----------------|---------------------------|
| 2097-V31PRO | 185 (7.29) |
| 2097-V31PR2 | |
| 2097-V32PRO | 230 (9.04) |
| 2097-V32PR2 | |
| 2097-V32PR4 | 185 (7.29) ⁽¹⁾ |
| 2097-V33PR1 | |
| 2097-V33PR3 | 230 (9.04) |
| 2097-V33PR5 | |
| 2097-V33PR6 | 185 (7.29) ⁽¹⁾ |
| 2097-V34PR3 | |
| 2097-V34PR5 | 230 (9.04) |
| 2097-V34PR6 | |

(1) If you are using an AC line filter, add 50 mm (2 in.).

- Mount the Kinetix 300 drive to the cabinet subpanel with an M4 (#6-32) steel machine screw torqued to 1.1 N•m (9.8 lb•in).

For catalog numbers 2097-V33PR1, 2097-V33PR3, 2097-V33PR5, 2097-V34PR3, and 2097-V34PR5 that use an AC line filter, refer to the AC Line Filter Installation Instructions, publication [2097-IN003](#), for the subpanel mounting hole pattern.

Kinetix 300 Drive Mounting Dimensions

Dimensions are in mm (in.).

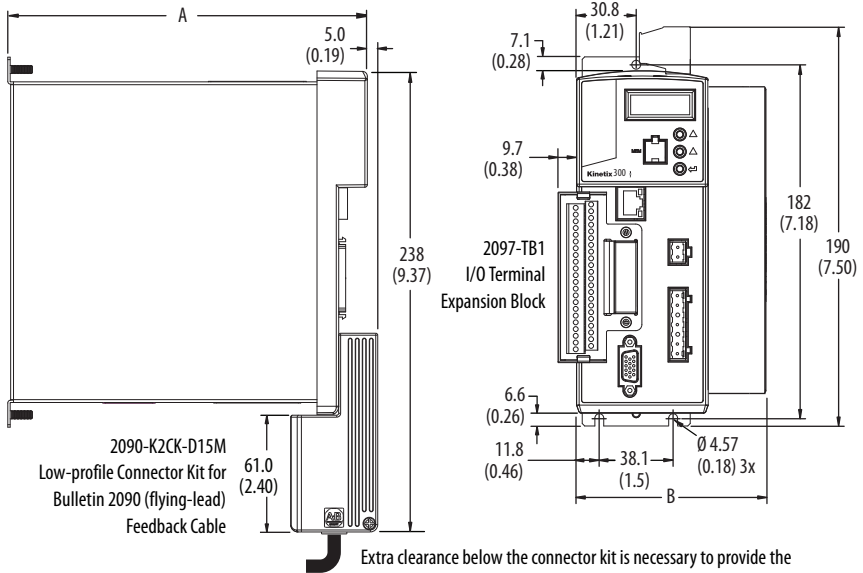

| Cat. No. | Dimensions mm (in.) | |
|-------------|---------------------|-------------|
| | A | B |
| 2097-V31PR0 | 185.1 (7.29) | 68.0 (2.68) |
| 2097-V31PR2 | 185.1 (7.29) | 68.5 (2.70) |
| 2097-V32PR0 | 229.6 (9.04) | 68.0 (2.68) |
| 2097-V32PR2 | 229.6 (9.04) | 68.5 (2.70) |
| 2097-V32PR4 | 229.6 (9.04) | 86.8 (3.42) |
| 2097-V33PR1 | 185.1 (7.29) | 68.0 (2.68) |

| Cat. No. | Dimensions mm (in.) | |
|-------------|---------------------|-------------|
| | A | B |
| 2097-V33PR3 | 185.1 (7.29) | 68.5 (2.70) |
| 2097-V33PR5 | 185.1 (7.29) | 94.4 (3.72) |
| 2097-V33PR6 | 229.6 (9.04) | 68.0 (2.68) |
| 2097-V34PR3 | 185.1 (7.29) | 68.5 (2.70) |
| 2097-V34PR5 | 185.1 (7.29) | 94.4 (3.72) |
| 2097-V34PR6 | 229.6 (9.04) | 68.0 (2.68) |

Connector Data

Use this illustration to identify the Kinetix 300 drive features and indicators.

Kinetix 300 Drive Features and Indicators

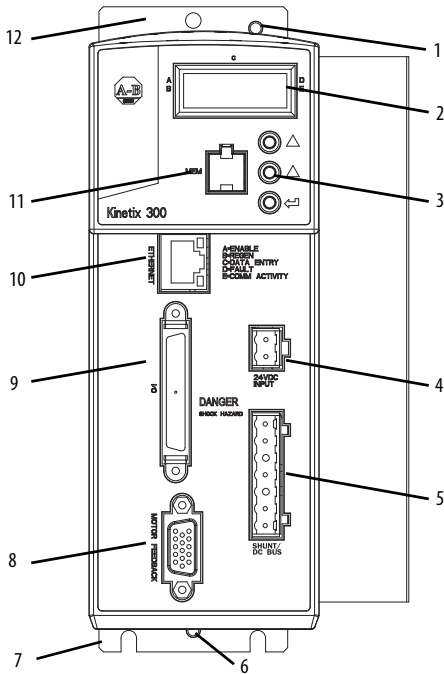

| Item | Description |
|------|--|
| 1 | Ground lug |
| 2 | Status and diagnostic display |
| 3 | Display-control push buttons (3) |
| 4 | Back-up power (BP) connector |
| 5 | Shunt resistor and DC bus (BC) connector |
| 6 | Ground lug |
| 7 | Bottom mounting flange |
| 8 | Motor feedback (MF) connector |
| 9 | I/O (IOD) connector |
| 10 | Ethernet communication port (Port 1) |
| 11 | Memory module |
| 12 | Top mounting flange |
| 13 | Mains (IPD) connector |
| 14 | Motor power (MP) connector |
| 15 | Safe torque-off (STO) connector |
| 16 | Heat sink (on some models) |

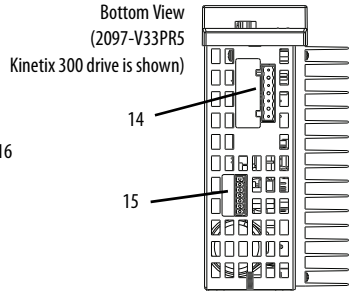
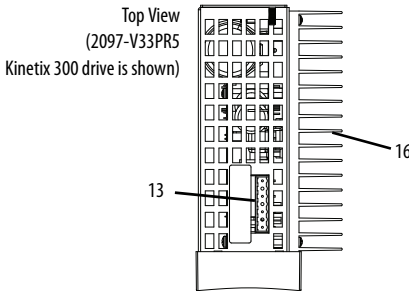

Kinetix 300 Drive Connectors

| Designator | Description | Connector |
|------------|--------------------------------|------------------------------------|
| IPD | AC mains input power | 4-position plug/header |
| PORT1 | Ethernet communication port | RJ45 Ethernet |
| IOD | I/O | SCSI 50-pin high-density connector |
| MF | Motor feedback | 15-pin high-density D-shell (male) |
| BP | Back-up power | 2-pin quick-connect terminal block |
| BC | Shunt resistor and DC bus | 5-pin quick-connect terminal block |
| MP | Motor power | 6-pin quick-connect terminal block |
| STO | Safe torque-off (STO) terminal | 6-pin quick-connect terminal block |

Mains (IPD) Connector Pinout

| IPD Designator | Description | Signal |
|----------------|------------------------------|--------|
| L3 | AC power in (3-phase models) | L3 |
| L2 | AC power in | L2 |
| L1 | AC power in | L1 |
| PE | Protective earth (ground) | PE |

Pin Orientation for 8-pin Ethernet Communication Port (port 1)

| Port 1 Pin | Description | Signal |
|------------|---------------------------------|--------|
| 1 | Transmit port (+) data terminal | + TX |
| 2 | Transmit port (-) data terminal | - TX |
| 3 | Receive port (+) data terminal | + RX |
| 4 | – | – |
| 5 | – | – |
| 6 | Receive port (-) data terminal | - RX |
| 7 | – | – |
| 8 | – | – |

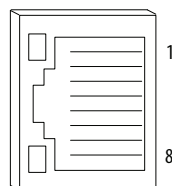

I/O (IOD) Connector Pinout

| IOD Pin | Description | Signal |
|---------|-------------------------------------|----------|
| 1 | Master encoder A+/Step+ input | MA+ |
| 2 | Master encoder A-/Step- input | MA- |
| 3 | Master encoder B+/Direction+ input | MB+ |
| 4 | Master encoder B-/Direction- input | MB- |
| 5 | Drive logic common | GND |
| 6 | Reserved | – |
| 7 | Buffered encoder output: channel A+ | BA+ |
| 8 | Buffered encoder output: channel A- | BA- |
| 9 | Buffered encoder output: channel B+ | BB+ |
| 10 | Buffered encoder output: channel B- | BB- |
| 11 | Buffered encoder output: channel Z+ | BZ+ |
| 12 | Buffered encoder output: channel Z- | BZ- |
| 13...21 | Reserved | – |
| 22 | Analog common | ACOM |
| 23 | Analog output (max 10 mA) | A0 |
| 24 | Positive (+) of analog signal input | AIN1+ |
| 25 | Negative (-) of analog signal input | AIN1- |
| 26 | Digital input group ACOM terminal | IN_A_COM |
| 27 | Digital input A1 | IN_A1 |
| 28 | Digital input A2 | IN_A2 |
| 29 | Digital input A3 | IN_A3 |
| 30 | Digital input A4 | IN_A4 |
| 31 | Digital input group BCOM terminal | IN_B_COM |
| 32 | Digital input B1 | IN_B1 |
| 33 | Digital input B2 | IN_B2 |
| 34 | Digital input B3 | IN_B3 |
| 35 | Digital input B4 | IN_B4 |
| 36 | Digital input Group CCOM Terminal | IN_C_COM |
| 37 | Digital input C1 | IN_C1 |
| 38 | Digital input C2 | IN_C2 |
| 39 | Digital input C3 | IN_C3 |

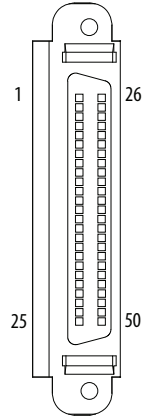

I/O (IOD) Connector Pinout (continued)

| IOD Pin | Description | Signal |
|---------|----------------------------------|--------|
| 40 | Digital input C4 | IN_C4 |
| 41 | Ready output collector | RDY+ |
| 42 | Ready output emitter | RDY- |
| 43 | Programmable output #1 collector | OUT1-C |
| 44 | Programmable output #1 emitter | OUT1-E |
| 45 | Programmable output #2 collector | OUT2-C |
| 46 | Programmable output #2 emitter | OUT2-E |
| 47 | Programmable output #3 collector | OUT3-C |
| 48 | Programmable output #3 emitter | OUT3-E |
| 49 | Programmable output #4 collector | OUT4-C |
| 50 | Programmable output #4 emitter | OUT4-E |

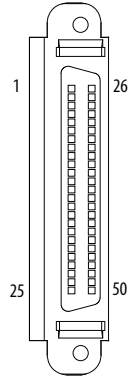

Control Power Back-up (BP) Connector Pinout

| BP Designator | Description | Signal |
|---------------|----------------------------|---------|
| +24V | Positive 24V DC | +24V DC |
| -24V | 24V DC power supply return | Return |

Shunt Resistor and DC Bus (BC) Pinout

| BC Designator | Description | Signal |
|---------------|------------------------------------|--------|
| + | Positive DC bus and shunt resistor | + |
| + | | + |
| SH | Shunt resistor | SH |
| - | Negative DC bus | - |
| - | | - |

Motor Power (MP) Pinout

| MP Designator | Description | Signal |
|---------------|---------------------------|--------|
| PE | Protective earth (ground) | PE |
| W | Motor power out | W |
| V | Motor power out | V |
| U | Motor power out | U |

Motor Feedback (MF) Connector Pinout

| MF Pin | Description ⁽¹⁾ | Signal |
|--------|---|------------------------|
| 1 | Sine differential input+ AM+ differential input+ | SIN+ AM+ |
| 2 | Sine differential input- AM- differential input- | SIN- AM- |
| 3 | Cosine differential input+ BM+ differential input+ | COS+ BM+ |
| 4 | Cosine differential input- BM- differential input- | COS- BM- |
| 5 | Data differential input + Index pulse+ | DATA+ IM+ |
| 6 | Common | ECOM |
| 7 | Encoder power (+9V) | EPWR_9V ⁽¹⁾ |
| 8 | Single-ended 5V Hall effect commutation | S3 |
| 9 | Reserved | — |
| 10 | Data differential input - Index pulse- | DATA- IM- |
| 11 | Motor thermal switch (normally closed) ⁽²⁾ | TS |
| 12 | Single-ended 5V Hall effect commutation | S1 |
| 13 | Single-ended 5V Hall effect commutation | S2 |
| 14 | Encoder power (+5V) | EPWR_5V ⁽¹⁾ |
| 15 | Reserved | — |

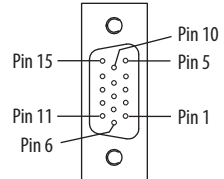

(1) Determine which power supply your encoder requires and connect to only the specified supply. Do not make connections to both.

(2) Not applicable unless motor has integrated thermal protection.



ATTENTION: To avoid damage to components, determine which power supply your encoder requires and connect encoder power to either the 5V or 9V supply, but not both.

Safe Torque-off (STO) Pinout

| STO Pin | Description | Signal |
|---------|------------------------------------|-----------------|
| 1 | +24V DC output from the drive | +24V DC Control |
| 2 | +24V DC output common | Control COM |
| 3 | Safety status | Safety Status |
| 4 | Safety input 1 (+24V DC to enable) | Safety Input 1 |
| 5 | Safety common | Safety COM |
| 6 | Safety input 2 (+24V DC to enable) | Safety Input 2 |

The Kinetix 300 drives ship with the safe torque-off circuitry enabled. Connect the safe torque-off inputs to a safety circuit or install motion-allowed jumpers to obtain motion. See the Kinetix 300 EtherNet/IP Indexing Servo Drives User Manual, publication [2097-UM001](#), for details.

Power Wiring Requirements

Wire must be copper with 75 °C (167 °F) minimum rating. The phase connections of the main AC power are arbitrary and an earth-ground connection is required for safe and proper operation.

IMPORTANT The National Electrical Code and local electrical codes take precedence over the values and methods provided.

Kinetix 300 Drive Power-Wiring Requirements

| Cat. No. | Description | Terminals | | Recommended Wire Size mm ² (AWG) | Strip Length mm (in.) | Torque Value N·m (lb·in) |
|--|-------------------|----------------------|--------|--|--------------------------|-----------------------------|
| | | Pin | Signal | | | |
| 2097-V31PRO 2097-V32PRO 2097-V32PR2 2097-V33PR1 2097-V33PR3 2097-V34PR3 2097-V34PR5 2097-V34PR6 | Mains input power | L3 L2 L1 PE | | 2.5 (14) | 7 (0.28) | 0.5 (4.5) |
| 2097-V32PR4 2097-V33PR5 | | | | 4.0 (12) | | |
| 2097-V31PR2 2097-V33PR6 | | | | 6.0 (10) | | |

Kinetix 300 Drive Power-Wiring Requirements (continued)

| Cat. No. | Description | Terminals | | Recommended Wire Size mm ² (AWG) | Strip Length mm (in.) | Torque Value N·m (lb·in) |
|---|--|--|---|--|--------------------------|-----------------------------|
| | | Pin | Signal | | | |
| 2097-V31PRO 2097-V32PRO 2097-V32PR2 2097-V32PR4 2097-V33PR1 2097-V33PR3 2097-V33PR5 2097-V34PR3 2097-V34PR5 2097-V34PR6 2097-V31PR2 | Motor power | | PE W V U | 2.5 (14) | 7 (0.28) | 0.5 (4.5) |
| 2097-V33PR6 | | | | 4.0 (12) | 7 (0.28) | 0.5 (4.5) |
| 2097-V31PRO 2097-V32PRO 2097-V32PR2 2097-V32PR4 2097-V33PR1 2097-V33PR3 2097-V33PR5 2097-V34PR3 2097-V34PR5 2097-V34PR6 2097-V31PR2 | Shunt resistor and DC bus ⁽¹⁾ | | + + SH - - | 2.5 (14) | 7 (0.28) | 0.5 (4.5) |
| 2097-V33PR6 | | | | 4.0 (12) | 7 (0.28) | 0.5 (4.5) |
| 2097-V3xPRx | Control back-up power | | +24V DC Return | | | |
| 2097-V3xPRx | Safe torque-off | STO-1 ⁽²⁾ STO-2 ⁽²⁾ STO-3 STO-4 STO-5 STO-6 | +24V DC Control Control COM Safety Status Safety Input 1 Safety COM Safety Input 2 | 1.5 (16) | 6 (0.25) | 0.5 (4.5) |

(1) Use only for shunt on.

(2) Use only for bypassing the STO circuit.

**ATTENTION:** To avoid personal injury and equipment damage, make sure

- Installation complies with specifications regarding wire types, conductor sizes, branch circuit protection, and disconnect devices. The National Electrical Code (NEC) and local codes outline provisions for safely installing electrical equipment.
- Motor power connectors are used only for connection purposes. Do not use motor power connectors to turn the unit on and off.
- Shielded power cables are grounded to help prevent potentially high voltages on the shield.

Ground Your Kinetix 300 Drive to the Subpanel

If the Kinetix 300 drive is mounted on a painted subpanel, ground to a bonded cabinet-ground bus with a braided ground strap or 4.0 mm² (12 AWG) solid-copper wire, 100 mm (3.9 in.) long.

Connect the Braided Ground Strap

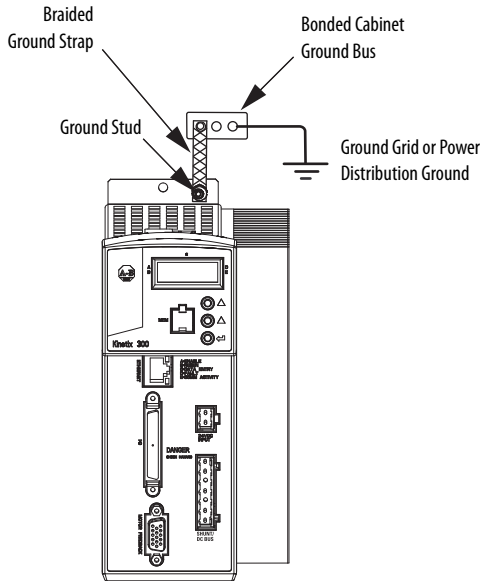

For dimensions, see [Kinetix 300 Drive Mounting Dimensions](#) on [page 6](#).

Kinetix 300 Drive Motor-power Wire Shielding

A motor-power ground clamp and two #6-32 x 1 screws are supplied with the Kinetix 300 drive. Install the supplied motor-power ground clamp within 50...75 mm (2...3 in.) of the drive by using the two #6-32 x 1 screws.

Motor-power Ground Clamp Installation

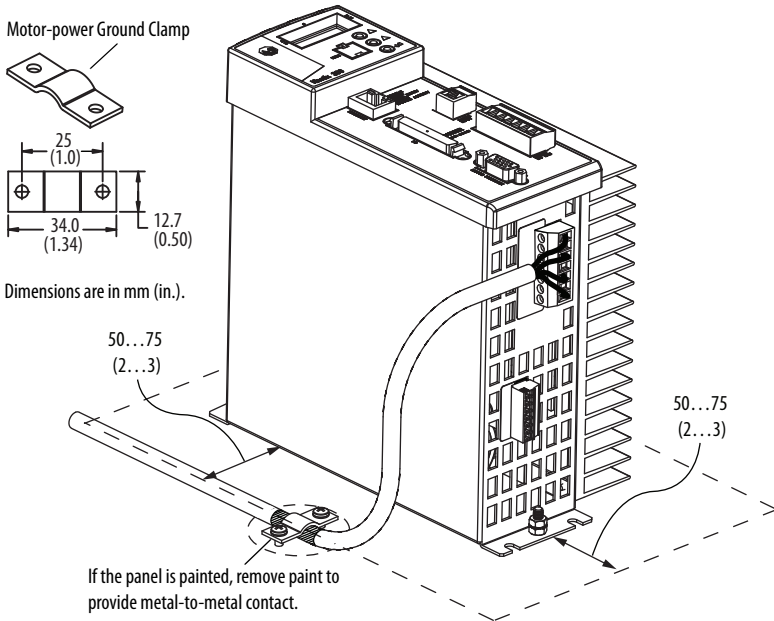

Motor Overload Protection

This servo drive uses solid-state motor overload protection that operates in accordance with UL 508C. Motor overload protection algorithms (thermal memory) predict actual motor temperature that is based on operating conditions as long as control power is continuously applied. However, when control power is removed, thermal memory is not retained.

This drive also provides an input for an external temperature sensor or thermistor device, which is embedded in the motor, to support the UL requirement for motor overload protection.

The drive supports some motors that do not contain temperature sensors or thermistors; therefore, motor overload protection against excessive consecutive motor overloads followed by power-up is not supported.

This servo drive meets the following UL 508C requirements for solid-state overload protection.

| Motor Overload Protection Trip Point | Value |
|--------------------------------------|---------------|
| Ultimately | 100% overload |
| Within 8 minutes | 200% overload |
| Within 20 seconds | 600% overload |



ATTENTION: Avoid overheating damage to your motor from excessive and successive motor overload faults by following the motor and drive-combination wiring diagram that is provided in the user manual.

See your servo drive user manual for the interconnect diagram that illustrates the wiring between your motor and drive.

Circuit Breaker/Fuse Selection

The Kinetix 300 drives use internal solid-state motor short-circuit protection. When protected by suitable branch circuit protection the drives are rated for use on a circuit that can deliver up to 100,000 A.

See Kinetix 300 Drive Power Specifications in Kinetix Servo Drives Specifications Technical Data, publication [GMC-TD003](#) for input current and inrush current specifications for your Kinetix 300 drive.

See [Circuit Breaker/Fuse Specifications](#) on page [17](#) and page [18](#) for recommended circuit breakers and fuses.

Circuit Breaker/Fuse Specifications

The following fuses and Allen-Bradley® circuit breakers are recommended for use with 2097-VxxPRx drives.

Fuse and Circuit Breaker Specifications for UL Applications

| Cat. No. | Drive Voltage | Phase | Fuses (Bussmann) Cat. No. | Miniature CB ⁽¹⁾ Cat. No. | Motor Protection CB, ⁽¹⁾⁽²⁾ Self-protected CMC Cat. No. |
|-------------|---------------|--------------------------------|---------------------------|--------------------------------------|--|
| 2097-V31PRO | 120V | Single-phase (voltage doubler) | KTK-R-20 (20A) | 1489-M1C200 | 140M-D8E-C20 |
| | 120/240V | Single-phase | KTK-R-10 (10A) | 1489-M1C100 | 140M-C2E-C10 |
| 2097-V31PR2 | 120V | Single-phase (voltage doubler) | KTK-R-30 (30A) | 1489-M1C300 | 140M-F8E-C32 |
| | 120/240V | Single-phase | KTK-R-20 (20A) | 1489-M1C200 | 140M-D8E-C20 |
| 2097-V32PRO | 240V | Single-phase | KTK-R-20 (20A) | 1489-M1C150 | 140M-D8E-C16 |
| 2097-V32PR2 | | | KTK-R-20 (20A) | 1489-M1C200 | 140M-D8E-C20 |
| 2097-V32PR4 | | | KTK-R-30 (30A) | 1489-M1C300 | 140M-F8E-C32 |
| 2097-V33PR1 | 120/240V | Single-phase | KTK-R-20 (20A) | 1489-M1C200 | 140M-D8E-C20 |
| | 240V | Three-phase | KTK-R-15 (15A) | 1489-M3C150 | 140M-D8E-C16 |
| 2097-V33PR3 | 120/240V | Single-phase | KTK-R-20 (20A) | 1489-M1C200 | 140M-D8E-C20 |
| | 240V | Three-phase | KTK-R-15 (15A) | 1489-M3C150 | 140M-D8E-C16 |
| 2097-V33PR5 | 120/240V | Single-phase | KTK-R-30 (30A) | 1489-M1C300 | 140M-F8E-C32 |
| | 240V | Three-phase | KTK-R-20 (20A) | 1489-M3C200 | 140M-D8E-C20 |
| 2097-V33PR6 | 120/240V | Single-phase | LPJ-40SP (40A) Class J | N/A | 140M-F8E-C32 |
| | 240V | Three-phase | KTK-R-30 (30A) | 1489-M3C300 | |
| 2097-V34PR3 | 480V | Three-phase | KTK-R-10 (10A) | 1489-M3C100 | 140M-C2E-C10 |
| 2097-V34PR5 | | | KTK-R-10 (10A) | 1489-M3C100 | 140M-C2E-C10 |
| 2097-V34PR6 | | | KTK-R-20 (20A) | 1489-M3C200 | 140M-D8E-C20 |

(1) Bulletin 1492 and 1489 circuit protection devices have lower short-circuit current ratings than Bulletin 140M devices. Refer to <http://ab.rockwellautomation.com/allenbradley/productdirectory.page?> for product literature with specific short-circuit ratings.

(2) For UL applications, Bulletin 140M devices are applied as self-protected combination motor controllers.

Fuse and Circuit Breaker Specifications IEC (non-UL) Applications

| Cat. No. | Drive Voltage | Phase | Miniature CB ⁽¹⁾ | | Motor Protection CB ⁽¹⁾ |
|-------------|---------------|--------------------------------|-----------------------------|---------------|------------------------------------|
| | | | Cat. No. | | Cat. No. |
| 2097-V31PR0 | 120V | Single-phase (voltage doubler) | 1489-M1C200 | 1492-SPM1D200 | 140M-D8E-C20 |
| | 120/240V | Single-phase | 1489-M1C100 | 1492-SPM1D100 | 140M-C2E-C10 |
| 2097-V31PR2 | 120V | Single-phase (voltage doubler) | 1489-M1C300 | 1492-SPM1D300 | 140M-F8E-C32 |
| | 120/240V | Single-phase | 1489-M1C200 | 1492-SPM1D200 | 140M-D8E-C20 |
| 2097-V32PR0 | 240V | Single-phase | 1489-M1C150 | 1492-SPM1D150 | 140M-D8E-C16 |
| 2097-V32PR2 | | | 1489-M1C200 | 1492-SPM1D200 | 140M-D8E-C20 |
| 2097-V32PR4 | | | 1489-M1C300 | 1492-SPM1D320 | 140M-F8E-C32 |
| 2097-V33PR1 | 120/240V | Single-phase | 1489-M1C200 | 1492-SPM1D200 | 140M-D8E-C20 |
| | 240V | Three-phase | 1489-M3C150 | 1492-SPM3D150 | 140M-D8E-C16 |
| 2097-V33PR3 | 120/240V | Single-phase | 1489-M1C200 | 1492-SPM1D200 | 140M-D8E-C20 |
| | 240V | Three-phase | 1489-M3C150 | 1492-SPM3D150 | 140M-D8E-C16 |
| 2097-V33PR5 | 120/240V | Single-phase | 1489-M1C300 | 1492-SPM1D300 | 140M-F8E-C32 |
| | 240V | Three-phase | 1489-M3C200 | 1492-SPM3D200 | 140M-D8E-C20 |
| 2097-V33PR6 | 120/240V | Single-phase | N/A | N/A | 140M-F8E-C32 |
| | 240V | Three-phase | 1489-M3C300 | 1492-SPM3D300 | |
| 2097-V34PR3 | 480V | Three-phase | 1489-M3C100 | 1492-SPM3D100 | 140M-C2E-C10 |
| 2097-V34PR5 | | | 1489-M3C100 | 1492-SPM3D100 | 140M-C2E-C10 |
| 2097-V34PR6 | | | 1489-M3C200 | 1492-SPM3D200 | 140M-D8E-C20 |

(1) Bulletin 1492 and 1489 circuit protection devices have lower short-circuit current ratings than Bulletin 140M devices.

Refer to <http://ab.rockwellautomation.com/allenbradley/productdirectory.page?> for product literature with specific short-circuit ratings

Additional Resources

These documents contain information about related products from Rockwell Automation.

| Resource | Description |
|---|---|
| Kinetix 300 EtherNet/IP Indexing Servo Drives User Manual, publication 2097-UM001 | Provides information on how to install, configure, start up, and troubleshoot your Kinetix 300 servo drive system. |
| Kinetix Servo Drives Specifications Technical Data, publication GMC-TD003 | Provides product specifications for Kinetix Integrated Motion over EtherNet/IP, Integrated Motion over SERCOS interface, EtherNet/IP network, and component servo drive families. |
| Kinetix Motion Accessories Specifications Technical Data, publication GMC-TD004 | Provides product specifications for Bulletin 2090 motor and interface cables, Low-profile connector kits, drive power components, and other servo drive accessory items. |

You can view or download publications at <http://www.rockwellautomation.com/literature>. To order paper copies of technical documentation, contact your local Allen-Bradley distributor or Rockwell Automation sales representative.

Rockwell Automation Support

Rockwell Automation provides technical information on the Web to assist you in using its products.

At <http://www.rockwellautomation.com/support> you can find technical and application notes, sample code, and links to software service packs. You can also visit our Support Center at <https://rockwellautomation.custhelp.com/> for software updates, support chats and forums, technical information, FAQs, and to sign up for product notification updates.

In addition, we offer multiple support programs for installation, configuration, and troubleshooting. For more information, contact your local distributor or Rockwell Automation representative, or visit <http://www.rockwellautomation.com/services/online-phone>.

Installation Assistance

If you experience a problem within the first 24 hours of installation, please review the information that's contained in this manual. You can also contact a special Customer Support number for initial help in getting your product up and running.

| | |
|---------------------------------|--|
| United States or Canada | 1.440.646.3434 |
| Outside United States or Canada | Use the Worldwide Locator at http://www.rockwellautomation.com/rockwellautomation/support/overview.page , or contact your local Rockwell Automation representative. |

New Product Satisfaction Return

Rockwell Automation tests all of its products to help ensure that they are fully operational when shipped from the manufacturing facility. However, if your product is not functioning and needs to be returned, follow these procedures.

| | |
|-----------------------|---|
| United States | Contact your distributor. You must provide a Customer Support case number (call the phone number above to obtain one) to your distributor to complete the return process. |
| Outside United States | Please contact your local Rockwell Automation representative for the return procedure. |

Documentation Feedback

Your comments will help us serve your documentation needs better. If you have any suggestions on how to improve this document, complete this form, publication [RA-DU002](#), available at <http://www.rockwellautomation.com/literature/>.

Rockwell Automation maintains current product environmental information on its website at <http://www.rockwellautomation.com/rockwellautomation/about-us/sustainability-ethics/product-environmental-compliance.page>.

Allen-Bradley, ControlLogix, CompactLogix, Kinetix, MicroLogix, Rockwell Software, and Rockwell Automation are trademarks of Rockwell Automation, Inc. Trademarks not belonging to Rockwell Automation are property of their respective companies.

Rockwell Otomasyon Ticaret A.Ş., Kar Plaza İş Merkezi E Blok Kat:6 34752 İçerenköy, İstanbul, Tel: +90 (216) 5698400

www.rockwellautomation.com

Power, Control and Information Solutions Headquarters

Americas: Rockwell Automation, 1201 South Second Street, Milwaukee, WI 53204-2496 USA, Tel: (1) 414.382.2000, Fax: (1) 414.382.4444
Europe/Middle East/Africa: Rockwell Automation NV, Pegasus Park, De Kleedlaan 12a, 1831 Diegem, Belgium, Tel: (32) 2 663 0600, Fax: (32) 2 663 0640
Asia Pacific: Rockwell Automation, Level 14, Core F, Cyberport 3, 100 Cyberport Road, Hong Kong, Tel: (852) 2887 4788, Fax: (852) 2508 1846

Publication 2097-IN001K-EN-P - September 2015

Supersedes Publication 2097-IN001J-EN-P - December 2014

Copyright © 2015 Rockwell Automation, Inc. All rights reserved. Printed in the U.S.A.

