

Kinetix VP Hygienic Servo Motor O-ring Kits

Catalog Numbers VPH-F063-ORING, VPH-F075-ORING, VPH-F100-ORING,
VPH-F115-ORING, VPH-F130-ORING, VPH-F165-ORING

The O-ring is intended to seal the gap between the motor front end-bell and the mounting plate. Sealing this area helps prevent the ingress of liquids onto the shaft and shaft seal. This greatly reduces the time required for cleaning the motor.

The O-ring material is approved for food and beverage applications and is compliant with FDA 21 CFR 177.2600.

IMPORTANT The O-ring kit is not required if the motor is fully enclosed and there is no exposure to, for example, liquids or dust.

Install the Bulletin VPH motor before you install the O-ring. See the Kinetix® VP Hygienic Servo Motors Installation Instructions, publication [VPH-IN001](#), for more information.

Follow these steps to install the O-ring.

1. Remove power to the motor.
2. Disconnect the load from the shaft.
3. Support the motor while you remove the motor mounting screws.

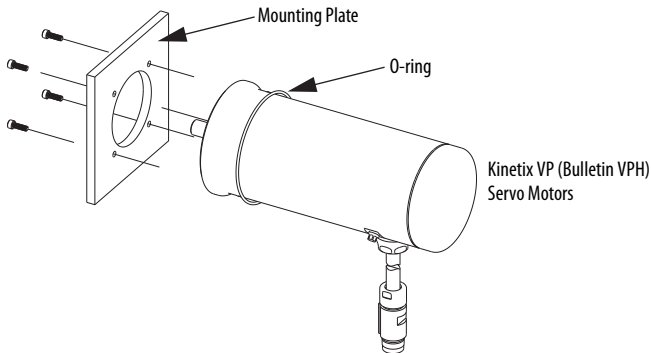

- Slide the O-ring over the motor shaft and front end-bell.
Be careful not to overstretch the O-ring and cause permanent deformation as you position the O-ring on the motor.
- Loosely install the motor on the mounting plate, leaving a small gap.
Gap of <2 mm (0.08 in.) provides space for O-ring to seat properly in the groove.

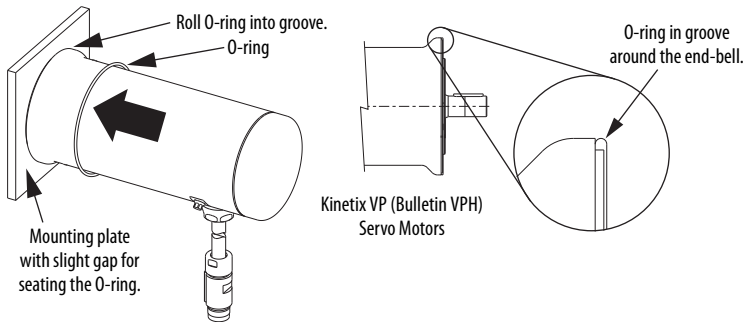

- Roll the O-ring into the groove on the front end-bell.

IMPORTANT Verify that the O-ring is seated in the groove around the end-bell.

- Tighten the motor mounting screws.

IMPORTANT Mounting plates with oversized clearance holes can cause the motor to shift during tightening. Verify that the O-ring has not shifted or has an irregular squeeze out.

O-ring Catalog Numbers

Motor Cat. No.	O-ring Kit Cat. No.
VPH-A063xx and VPH-B063x	VPH-F063-ORING
VPH-A075xx and VPH-B075x	VPH-F075-ORING
VPH-A100xx and VPH-B100x	VPH-F100-ORING

Motor Cat. No.	O-ring Kit Cat. No.
VPH-A115xx and VPH-B115xx	VPH-F115-ORING
VPH-A130xx and VPH-B130xx	VPH-F130-ORING
VPH-B165xx	VPH-F165-ORING

Rockwell Automation maintains current product environmental information on its website at <http://www.rockwellautomation.com/rockwellautomation/about-us/sustainability-ethics/product-environmental-compliance.page>.

Allen-Bradley, Kinetix, Rockwell Automation, and Rockwell Software are trademarks of Rockwell Automation, Inc. Trademarks not belonging to Rockwell Automation are property of their respective companies.

Rockwell Otomasyon Ticaret A.Ş., Kar Plaza İş Merkezi E Blok Kat:6 34752 İçerenköy, İstanbul, Tel: +90 (216) 5698400

www.rockwellautomation.com

Power, Control and Information Solutions Headquarters

Americas: Rockwell Automation, 1201 South Second Street, Milwaukee, WI 53204-2496 USA, Tel: (1) 414.382.2000, Fax: (1) 414.382.4444
Europe/Middle East/Africa: Rockwell Automation NV, Pegasus Park, De Kleetlaan 12a, 1831 Diegem, Belgium, Tel: (32) 2 663 0600, Fax: (32) 2 663 0640
Asia Pacific: Rockwell Automation, Level 14, Core F, Cyberport 3, 100 Cyberport Road, Hong Kong, Tel: (852) 2887 4788, Fax: (852) 2508 1846



PN-522272