



# Industrial Automation Wiring and Grounding Guidelines

## Purpose

This publication gives you general guidelines for installing an Allen-Bradley industrial automation system that may include programmable controllers, industrial computers, operator-interface terminals, display devices, and communication networks. **While these guidelines apply to the majority of installations, certain electrically harsh environments may require additional precautions.**

Use these guidelines as a tool for helping avoid potential electromagnetic interference (emi) and transient emi that could cause problems such as “adapter faults, rack faults, communication faults,” etc. These guidelines are not intended to supersede local electrical codes.

This publication is organized into the following sections:

- Raceway layout considerations
- Mounting, bonding, and grounding
- Power distribution
- Surge-suppression
- Ferrite beads
- Enclosure lighting
- Avoiding unintentional momentary turn-on of outputs
- Related publications

## Raceway Layout Considerations

The raceway layout of a system is reflective of where the different types of I/O modules are placed in I/O chassis. Therefore, you should determine I/O-module placement prior to any layout and routing of wires. However, when planning your I/O-module placement, segregate the modules based upon the conductor categories published for each I/O module so that you can follow these guidelines. Also, all conductors (ac or dc) in the same raceway must be insulated for the highest voltage applied to any one of the conductors in the raceway. These guidelines coincide with the guidelines for “the installation of electrical equipment to minimize electrical noise inputs to controllers from external sources” in IEEE standard 518-1982.

## Categorize Conductors

Segregate all wires and cables into the following three categories (Table A). Refer to the publication for each specific I/O module or block for individual conductor-category classification of each I/O line.

**Table A**  
Follow these Guidelines for Grouping Conductors with Respect to Noise

Group conductor cables fitting this description	Into this category:	Examples:
Control & ac Power — high-power conductors that are more tolerant of electrical noise than category 2 conductors and may also cause more noise to be picked up by adjacent conductors <ul style="list-style-type: none"> <li>corresponds to IEEE levels 3 (low susceptibility) &amp; 4 (power)</li> </ul>	Category 1	<ul style="list-style-type: none"> <li>ac power lines for power supplies and I/O circuits.</li> <li>high-power digital ac I/O lines — to connect ac I/O modules rated for high power and high noise immunity</li> <li>high-power digital dc I/O lines — to connect dc I/O modules rated for high power or with input circuits with long time-constant filters for high noise rejection. They typically connect devices such as hard-contact switches, relays, and solenoids.</li> </ul>
Signal & Communication — low-power conductors that are less tolerant of electrical noise than category-1 conductors and should also cause less noise to be picked up by adjacent conductors (they connect to sensors and actuators relatively close to the I/O modules) <ul style="list-style-type: none"> <li>corresponds to IEEE levels 1 (high susceptibility) &amp; 2 (medium susceptibility)</li> </ul>	Category 2	<ul style="list-style-type: none"> <li>analog I/O lines and dc power lines for analog circuits</li> <li>low-power digital ac/dc I/O lines — to connect to I/O modules that are rated for low power such as low-power contact-output modules</li> <li>low-power digital dc I/O lines — to connect to dc I/O modules that are rated for low power and have input circuits with short time-constant filters to detect short pulses. They typically connect to devices such as proximity switches, photo-electric sensors, TTL devices, and encoders</li> <li>communication cables (ControlNet™, DeviceNet™, Universal remote I/O, extended-local I/O, DH+™, DH-485, RS-232-C, RS-422, RS-423 cables) — to connect between processors or to I/O adapter modules, programming terminals, computers, or data terminals</li> </ul>
Intra-enclosure — interconnect the system components within an enclosure <ul style="list-style-type: none"> <li>corresponds to IEEE levels 1 (high susceptibility) &amp; 2 (medium susceptibility)</li> </ul>	Category 3	<ul style="list-style-type: none"> <li>low-voltage dc power cables — provide backplane power to the system components</li> <li>communication cables — to connect between system components within the same enclosure</li> </ul>

NOTE: Remote I/O and DH+ cables must be made of catalog number 1770-CD cable or a cable from the approved-vendor list (publication ICCG-2.2). DH-485 cables must be made of a cable from the approved-vendor list in publication 1770-6.2.2.

## Route Conductors

To guard against coupling noise from one conductor to another, follow these general guidelines (Table B) when routing wires and cables (both inside and outside of an enclosure). Use the spacing given in these general guidelines with the following exceptions:

- where connection points (for conductors of different categories) on a device are closer together than the specified spacing
- application-specific configurations for which the spacing is described in a publication for that specific application

These guidelines are for noise immunity only. Follow all local codes for safety requirements.

**Table B**  
Follow these Guidelines for Routing Cables to Guard Against Noise

Route this category of conductor cables:	According to these guidelines:
Category 1	These conductors can be routed in the same cable tray or raceway with machine power conductors of up to 600V ac (feeding up to 100 hp devices).
Category 2	<ul style="list-style-type: none"> <li>• If it must cross power feed lines, it should do so at right angles.</li> <li>• Route at least 5 ft from high-voltage enclosures, or sources of rf/microwave radiation.</li> <li>• If the conductor is in a metal wireway or conduit, each segment of that wireway or conduit must be bonded to each adjacent segment so that it has electrical continuity along its entire length, and must be bonded to the enclosure at the entry point.</li> <li>• Properly shield (where applicable) and route in a raceway separate from category-1 conductors.</li> <li>• If in a <b>contiguous metallic wireway or conduit</b>, route at least 0.08m (3 in) from category-1 conductors of less than 20A; 0.15m (6 in) from ac power lines of 20A or more, but only up to 100 kVA; 0.3m (1 ft) from ac power lines of greater than 100 kVA.</li> <li>• If <b>not in a contiguous metallic wireway or conduit</b>, route at least 0.15m (6 in) from category-1 conductors of less than 20A; 0.3m (1 ft) from ac power lines of 20A or more, but only up to 100 kVA; 0.6m (2 ft) from ac power lines of greater than 100 kVA.</li> </ul>
Category 3	Route conductors external to all raceways in the enclosure or in a raceway separate from any category-1 conductors with the same spacing listed for category-2 conductors, where possible.

**Important: These guidelines assume that you follow the surge-suppression guidelines (page 15). While these guidelines apply to the majority of installations, certain electrically harsh environments may require additional precautions.**

The use of the guidelines in Table B are illustrated in Figure 1.

**Figure 1**  
**Mounting Assembly Details**

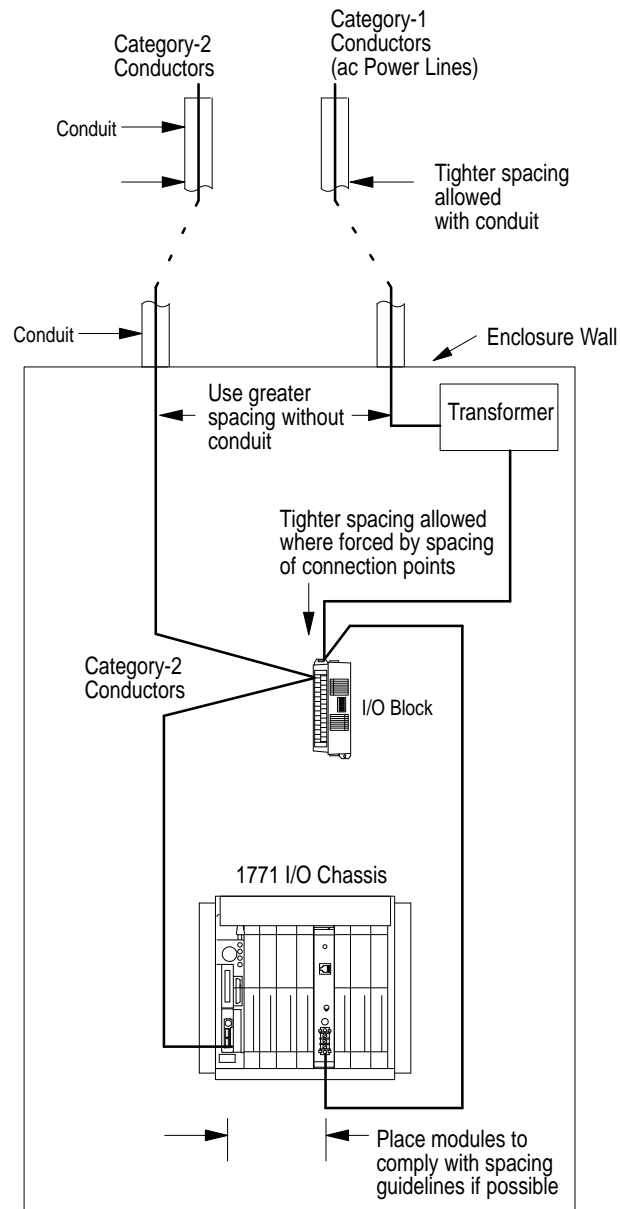

12618-1

## Mounting, Bonding, and Grounding

After establishing all layouts, you can begin mounting, bonding, and grounding each chassis. Bonding is the connecting together of metal parts of chassis, assemblies, frames, shields, and enclosures to reduce the effects of emi and ground noise. Grounding is the connection to the grounding-electrode system to place equipment at earth ground potential.

### Mounting and Bonding the Chassis

You can mount the chassis with either bolts or welded studs. Figure 2 shows details for:

- stud-mounting a ground bus or chassis to the back panel of the enclosure
- stud-mounting a back panel to the enclosure
- bolt-mounting a ground bus or chassis to the back panel of the enclosure

If the mounting brackets of a chassis do not lay flat before the nuts are tightened, use additional washers as shims so that the chassis does not bend when you tighten the nuts.

**Important:** Do not bend the chassis. Bending the chassis might damage the backplane and result in poor connections.

**Figure 2**  
Mounting Assembly Details

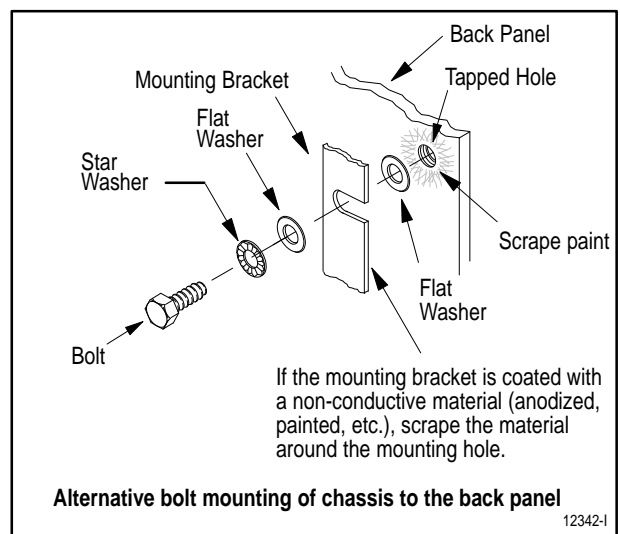
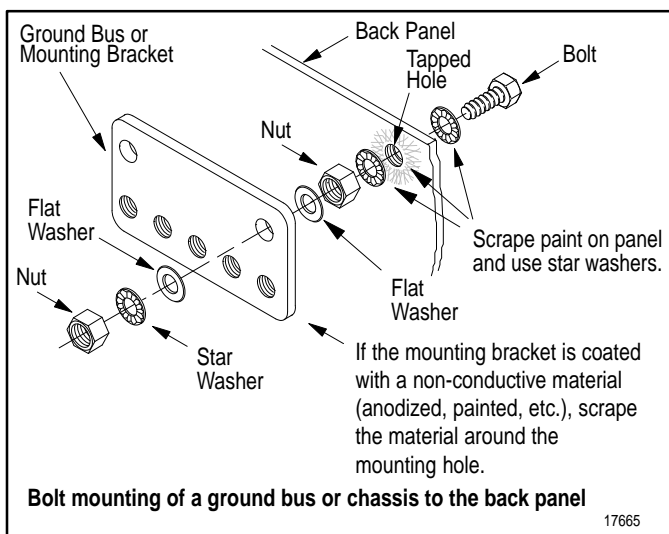
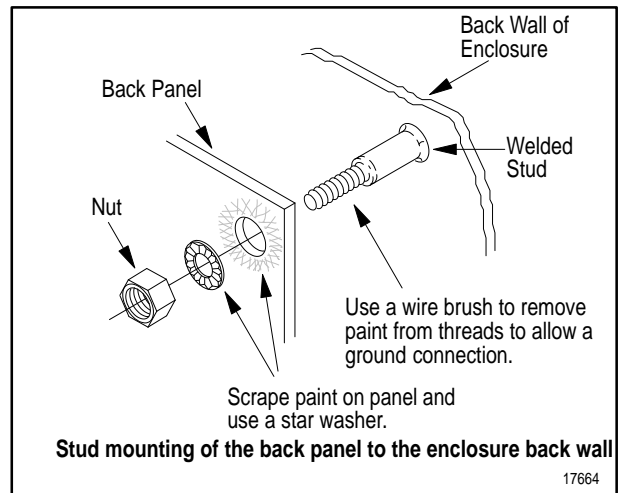
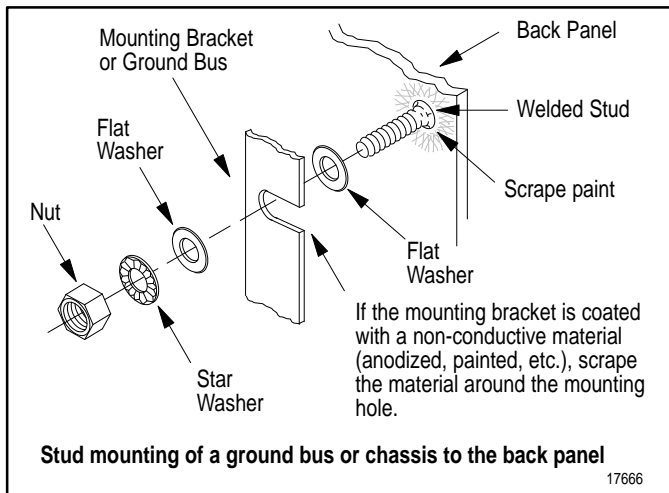

Make good electrical connection between each chassis, back-panel, and enclosure through each mounting bolt or stud. Wherever contact is made, remove paint or other non-conductive finish from around studs or tapped holes.

### Bonding and Grounding the Chassis

With solid-state controls, proper bonding and grounding helps reduce the effects of emi and ground noise. Also, since bonding and grounding are important for safety in electrical installations, local codes and ordinances dictate which bonding and grounding methods are permissible.

For example, for U.S. installations, the National Electrical Code (NEC) gives you the requirements for safe bonding and grounding, such as information about the size and types of conductors and methods of safely grounding electrical components.

**Equipment-Grounding Conductor** — In addition to making good connections through each bolt or stud, use either 1-inch copper braid or 8 AWG minimum stranded copper wire to connect each chassis, enclosure and central ground bus mounted on the back-panel. Figure 3 shows ground-bus connection details.

**Figure 3**  
Ground Bus Connection Details

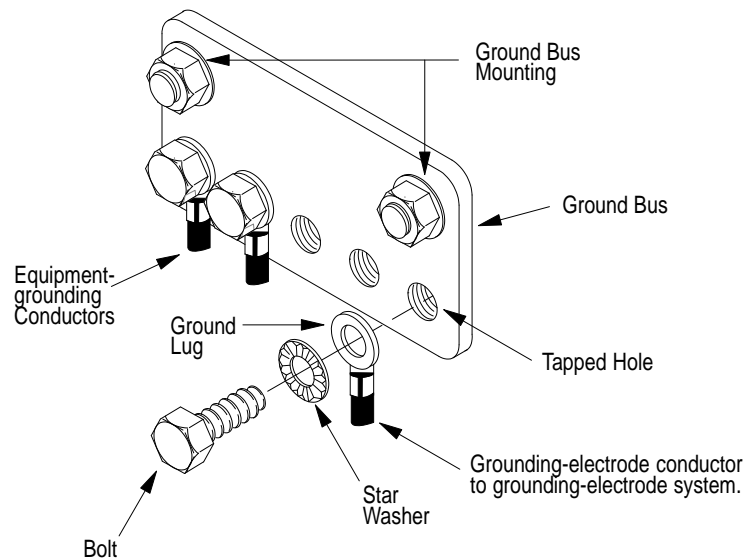

13271

Figure 4 shows enclosure-wall ground connection details. Use a steel enclosure to guard against emi. If the enclosure door has a viewing window, it should be a laminated screen or a conductive optical substrate to block emi. Do not rely on the hinge for electrical contact between the door and the enclosure; install a bonding wire.

**Figure 4**  
**Details of Ground Connection at Enclosure Wall**

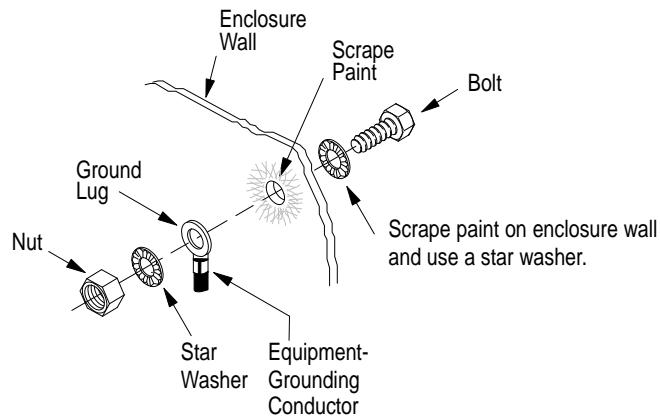

10020

Connect an equipment grounding conductor directly from each chassis to an individual bolt on the ground bus. For a chassis with no ground stud, use a mounting bolt (Figure 5). For those chassis with a ground stud, use the ground stud for this connection (Figure 6).

**Figure 5**  
**Details of Ground Connection at Mounting Bracket of Chassis with No Ground Stud**

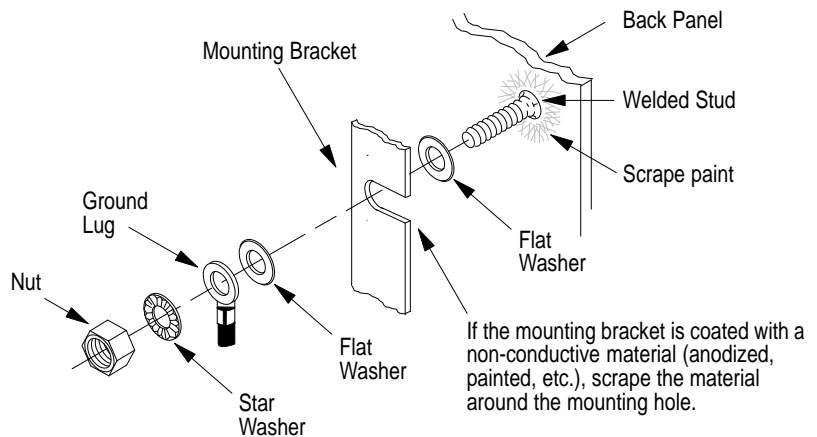

17666

For a power supply without a groundable power supply chassis (such as a power-supply module or mini-processor with an integral power supply), or a power supply (such as the 1771-P7 or 1771-PS7) with a chassis that is not internally connected to its GND terminal, use a 14 AWG copper wire to connect its GND terminal to the ground stud or mounting bolt connected to the ground bus. This will ensure an adequate ground for noise immunity.

**Figure 6**  
**Typical Grounding Configuration**

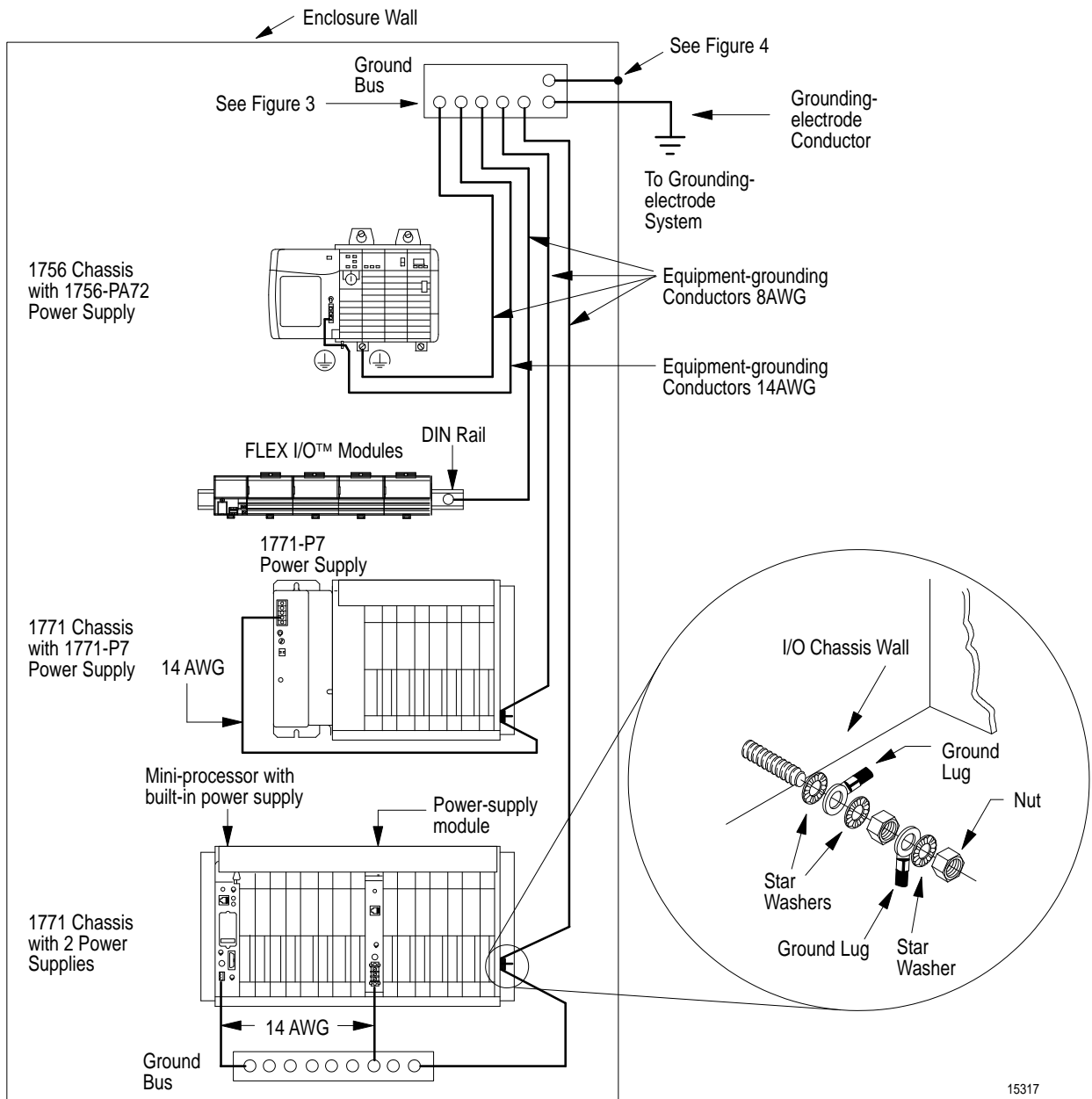

Do not lay one ground lug directly on top of the other. This type of connection can become loose due to compression of the metal lugs. Sandwich the first lug between a star washer and a nut with a captive star washer. After tightening the nut, sandwich the second lug between the first nut and a second nut with a captive star washer.



Some products have no visible groundable chassis and no ground lug or ground terminal, but mount on a DIN rail. The FLEX I/O products are in this category. The chassis of these products are grounded only thru the DIN rail. For these products, connect an equipment-grounding conductor directly from the mounting bolt on the DIN rail to an individual bolt on the ground bus.

**Grounding-Electrode Conductor** — Connect the ground bus to the grounding-electrode system through a grounding-electrode conductor. The grounding-electrode system is at earth-ground potential and is the central ground for all electrical equipment and ac power within any facility. Use 8 AWG copper wire minimum for the grounding-electrode conductor to help guard against emi. The National Electrical Code specifies safety requirements for the grounding-electrode conductor.

**Shielded Cables** — Certain I/O connections require shielded cables to help reduce the effects of electrical noise coupling. Ground each shield at one end only. A shield grounded at both ends forms a ground loop which can cause a processor to fault.

Ground each shield at the end specified in the appropriate publication for the product. Never connect a shield to the common side of a logic circuit (this would introduce noise into the logic circuit). Connect each shield directly to a chassis ground.

For some communication network cables, the shield connections are unique to the particular cabling system. In some such cases, a dc short to ground is not needed because a low-impedance ac path to ground and a high-impedance dc path to ground are provided internally at each node. Follow the specific instructions in the publication provided for the specific communication network cabling system.

Avoid breaking shields at junction boxes. Many types of connectors for shielded conductors are available from various manufacturers. If you do break a shield at a junction box, do the following:

- Connect only category-2 conductors in the junction box.
- Do not strip the shield back any further than necessary to make a connection.
- Connect the shields of the two cable segments to ensure continuity along the entire length of the cable.

## Power Distribution

You can connect the power supply directly to the secondary of a transformer (Figures 7 and 8). The transformer provides dc isolation from other equipment not connected to that transformer secondary. Connect the transformer primary to the ac source; connect the high side of the transformer secondary to the L1 terminal of the power supply; connect the low side of the transformer secondary to the neutral (common) terminal of the power supply.

**Figure 7**  
Grounded ac Power-Distribution System with Master-Control Relay

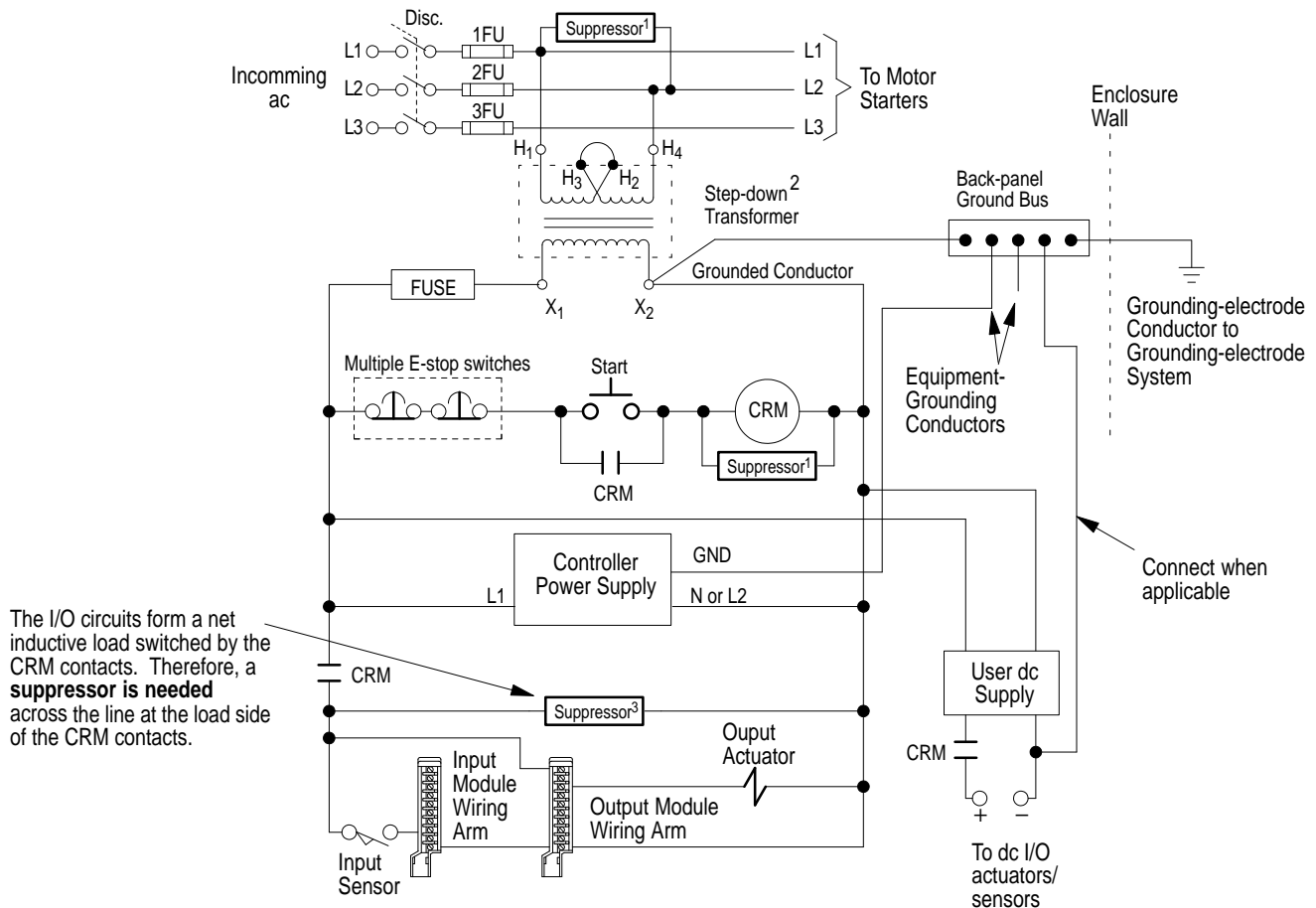

**Notes:**

- 1 To minimize emi generation, connect a suppressor across an inductive load. For suppressors to use, refer to 11 and C or the Electrocube catalog.
- 2 In many applications, a second transformer provides power to the input circuits and power supplies for isolation from the output circuits.
- 3 Connect a suppressor here to minimize emi generation from the net inductive load switched by the CRM contacts. In some installations, a 1 $\mu$ f 220 $\Omega$  suppressor (Allen-Bradley 700-N5) or 2 $\mu$ f 100 $\Omega$  suppressor (Electrocube PN RG1676-7) has been effective. For suppressors to use, refer to Figure 11 and Table C or the Electrocube catalog.

19241

Connect one input directly to the L1 side of the line, on the load side of the CRM contacts, to detect whether the CRM contacts are closed. In the ladder logic, use this input to hold off all outputs anytime the CRM contacts are open. (Refer to your programming manual.) If you fail to do this, closing the CRM contacts could generate transient emi because outputs are already turned on. To have outputs turned on when CRM contacts are closing would be analogous to squeezing the trigger on a hand tool as you're plugging it in.

**Figure 8**  
**Ungrounded ac Power-Distribution System with**  
**Master-Control Relay**

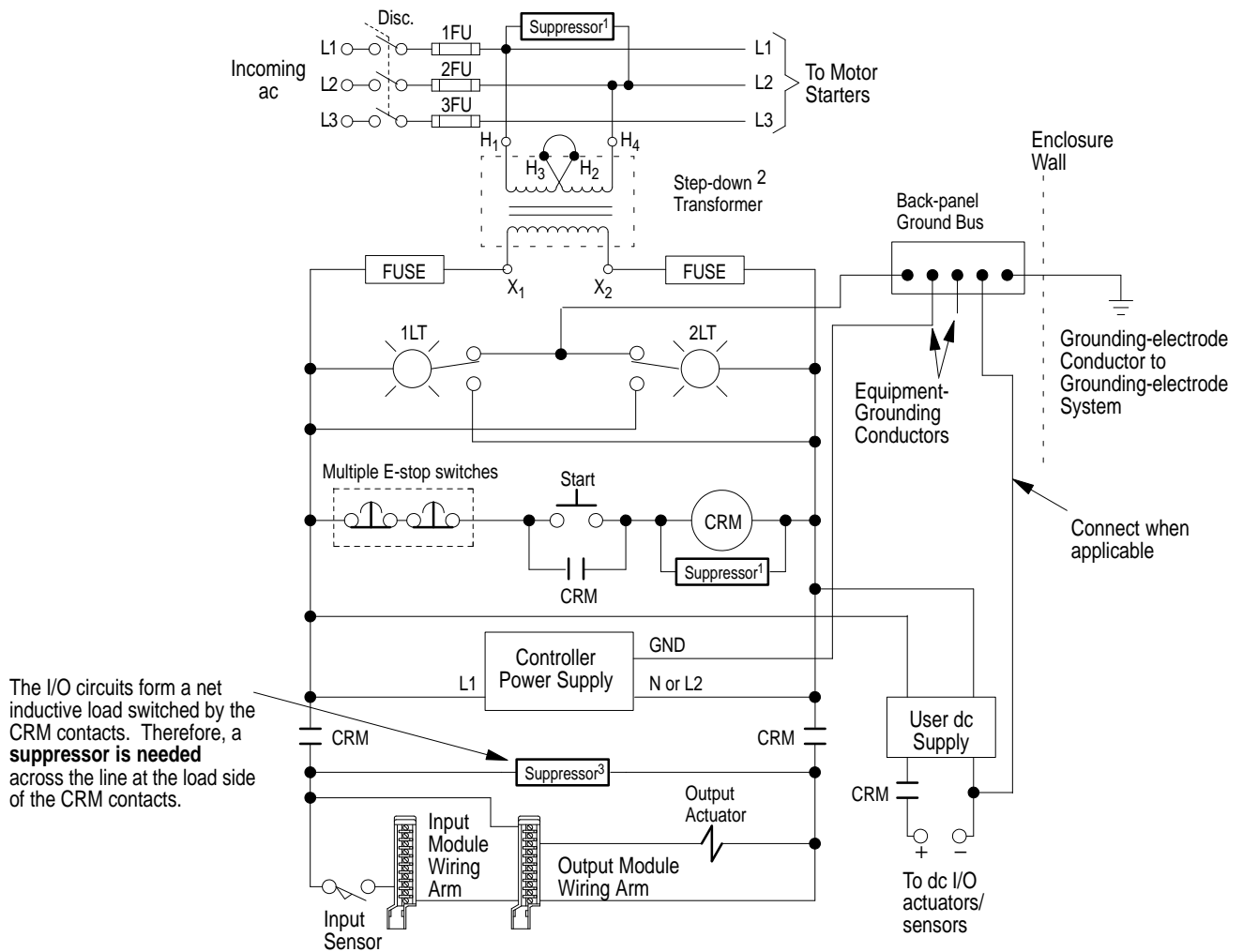

Notes:

- 1 To minimize emi generation, connect a suppressor across an inductive load. For suppressors to use, refer to 11 and C or the Electrocube catalog.
- 2 In many applications, a second transformer provides power to the input circuits and power supplies for isolation from the output circuits.
- 3 Connect a suppressor here to minimize emi generation from the net inductive load switched by the CRM contacts. In some installations, a 1µf 220Ω suppressor (Allen-Bradley 700-N5) or 2µf 100Ω suppressor (Electrocube PN RG1676-7) has been effective. For suppressors to use, refer to Figure 11 and Table C or the Electrocube catalog.

### **Common Power Source for I/O**

Unless each I/O of a module or block is individually isolated, multiple I/O within the block or module share a common terminal for one side of the power source. All I/O sharing a common terminal must share a common power source (i.e., from the same pole of a disconnect or from the same transformer tap).

If a module or block has multiple commons, each common and its I/O may be isolated from the other commons. In that case, each common and its I/O can have a separate power source. If each I/O is individually isolated, each I/O can have a separate power source. If a module or block has individually isolated I/O or multiple isolated commons and multiple power sources are used, be certain that the difference in potential between any two power sources does not exceed the specified maximum continuous voltage that can be applied between the channels.

### **Under-Voltage Shutdown**

Each power supply with under-voltage shut-down protection generates a shut-down signal on the backplane when the ac line voltage drops below its lower voltage limit. The power supply removes the shut-down signal when the line voltage comes back above the lower voltage limit. This shut-down is to guard against invalid data being stored in memory.

Because a capacitive-input power supply converting ac to dc draws power only from the peak of the ac voltage wave-form, the external transformer load (in VA) of each power supply is 2.5 times its real power dissipation (in Watts). If the transformer is too small, the peaks of the sine wave are clipped. Even if the voltage is still above the lower voltage limit, the power supply senses the clipped wave as low voltage and sends the shut-down signal.

### **Sizing the Transformer**

To determine the required rating of the transformer add the external-transformer load of the power supply and all other power requirements (input circuits, output circuits). The power requirements must take into consideration the surge currents of devices controlled by the processor. Choose a transformer with the closest standard transformer rating above the calculated requirements.

For example, the external-transformer load of a 1771-P4S power-supply module at maximum backplane load current is 140VA ( $2.5 \times 56W = 140$ ). A 140VA transformer could be used if a 1771-P4S power-supply module were the only load. A 500VA transformer should be used if there were 360VA of load in addition to that of the 1771-P4S power-supply module.

## Second Transformer

Allen-Bradley power supplies have circuits that suppress electromagnetic interference from other equipment. However, isolate output circuits from power supplies and input circuits to help prevent output transients from being induced into inputs and power supplies. In many applications, power is provided to the input circuits and power supplies through a second transformer (Figure 9).

**Figure 9**  
Power Supplies and Input Circuits Receiving Power through a Separate Transformer

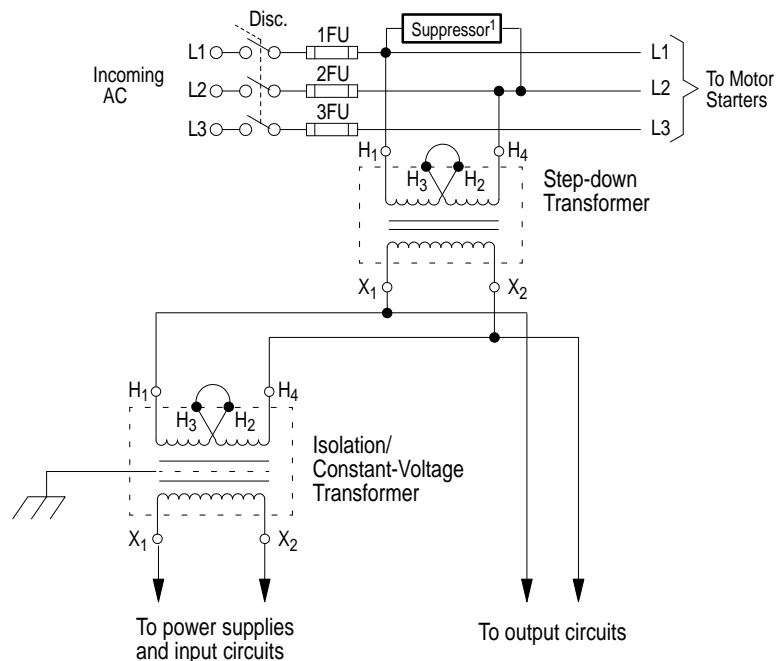

Notes:

- 1 To minimize transient emi generation when power is interrupted by the interrupt switch, connect a suppressor across the primary of the transformer. Refer to Figure 11 and Table C for suppressors to use.

19242

**Isolation Transformer** — For applications near excessive electrical noise generators, an isolation transformer (for the second transformer) provides further suppression of electromagnetic interference from other equipment. The output actuators being controlled should draw power from the same ac source as the isolation transformer, but not from the secondary of the isolation transformer (Figure 9).

**Constant-Voltage Transformer** — In applications where the ac power source is especially “soft” and subject to unusual variations, a constant-voltage transformer can stabilize the ac power source to the processor and minimize shutdowns. The constant-voltage transformer must be of the harmonic neutralizing type.

If the power supply receives its ac power through a constant-voltage transformer, the input sensors connected to the I/O chassis should also receive their ac power from the same constant-voltage transformer. If the inputs receive their ac power through another transformer, the ac source voltage could go low enough that erroneous input data enters memory while the constant-voltage transformer prevents the power supply from shutting down the processor. The output actuators being controlled should draw power from the same ac sources as the constant-voltage transformer, but not from the secondary of the constant-voltage transformer (9).

## Ground Connection

When ac power is supplied as a separately derived system through an isolation/step-down transformer, you can connect it as a grounded ac system or an ungrounded ac system. For a grounded ac system, connect one side of the transformer secondary to the ground bus as in Figure 7. For an ungrounded ac system, connect one side of each test switch for the ground-fault-detector lights to the ground bus as in Figure 8. We do not recommend an ungrounded system. Follow local codes in determining whether to use a grounded system.

When bringing ac power into the enclosure, do not ground its raceway to the ground bus on the back-panel. Connecting the raceway to the ground bus may cause the processor to fault by introducing emi into the grounding circuit. Local codes may provide an exception for permitting isolation from the raceway. For example, article 250-75 of the National Electrical Code has an exception that explains the conditions under which this isolation from the raceway is permitted.

## Surge-Suppression

Transient emi can be generated whenever inductive loads such as relays, solenoids, motor starters, or motors are operated by “hard contacts” such as pushbutton or selector switches. The wiring guidelines are based on the assumption that you guard your system against the effects of transient emi by using surge-suppressors to suppress transient emi at its source. Inductive loads switched by solid-state output devices alone do not require surge-suppression. However, inductive loads of ac output modules that are in series or parallel with hard contacts require surge-suppression to protect the module output circuits as well as to suppress transient emi.

Figure 10 shows 3 examples of where to use suppressors. In example 1, although the motor-starter coil is an inductive load, it does not need a suppressor because it is switched by a solid-state device alone. In example 2, the relay coil needs a suppressor because a hard-contact switch is in series with the solid-state switch. However, in both examples 1 and 2, we show a suppressor on the motor and solenoid because it is an inductive load switched by the hard contacts of the motor starter or relay. **Even if they have no interaction with the control system, regularly cycled loads of this type need suppression if conductors connecting to these loads are: 1) connected to the same separately derived system as that of the control system; 2) or routed in proximity with conductors of the control system as per the routing guidelines.**

In example 3, the pilot light has a built-in step-down transformer that needs a suppressor because it is an inductive load being switched by the hard contacts of a contact output module; without suppression, the transient emi would be generated inside the I/O chassis. Lights with built-in step-down transformers that are switched by hard contacts external to any I/O chassis may not need to be suppressed because the noise spike they can generate may be only approximately one tenth that of a relay or motor starter.

In all cases, the ac power coming into the I/O modules must be switched by the CRM contacts. Therefore, a suppressor is needed across the line at the load side of the CRM contacts as shown in Figures 7 and 8. The application (voltage, net load of I/O circuits) dictates the specific suppressor needed across the line at the load side of the CRM contacts.

**Figure 10**  
Examples of where to use Suppression

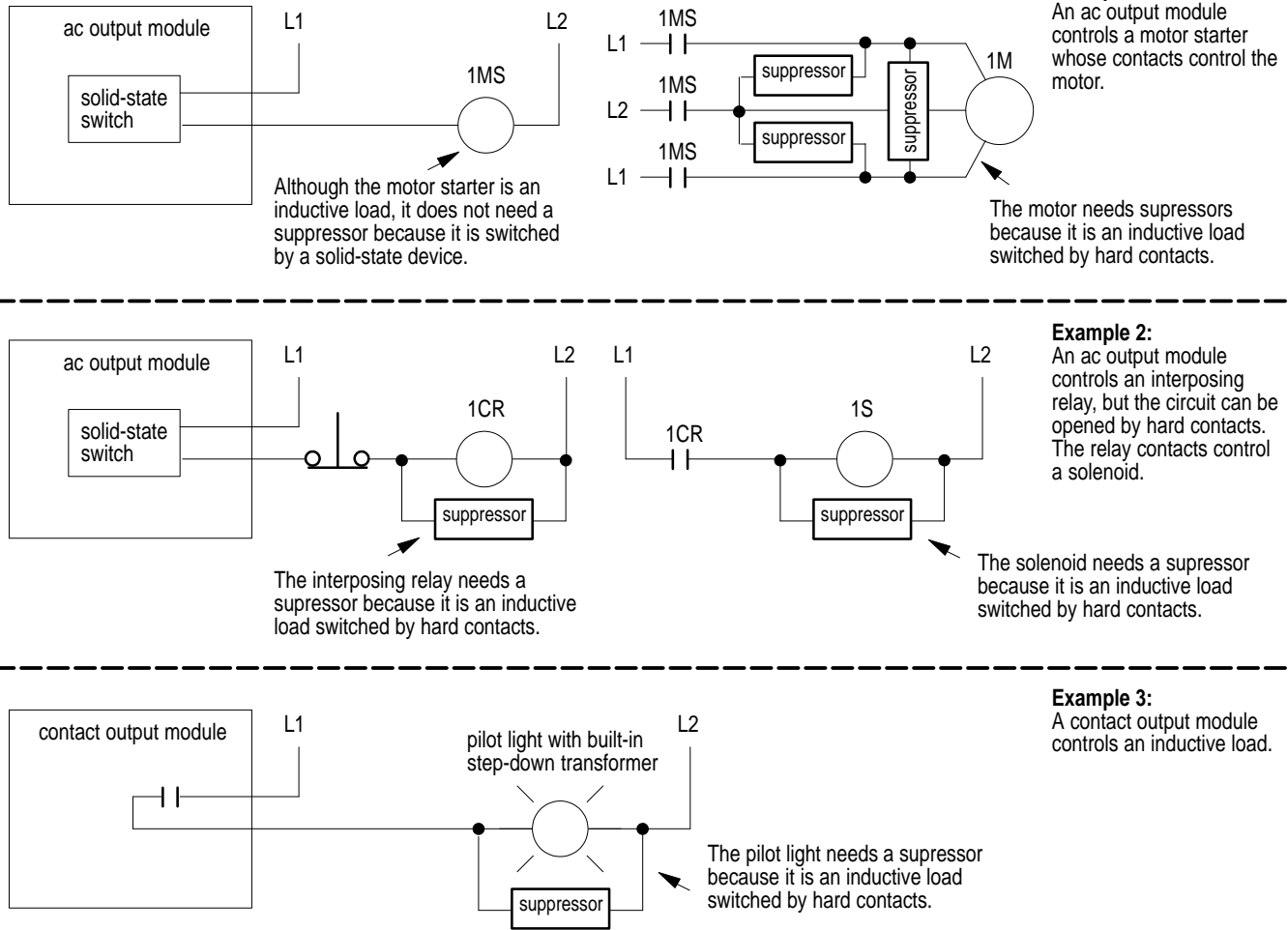

12597-1

Figure 11 shows typical suppression circuitry for different types of loads. Allen-Bradley bulletin 700 relays and bulletin 509 and bulletin 709 motor starters have surge-suppressors for their coils available as an option. Table C lists some Allen-Bradley products and their suppressors. See the Allen-Bradley Industrial Control Catalog for more information on suppressors including Bulletin 1492 surge-suppressor terminal blocks.



**Figure 11**  
**Typical Suppression Applications**

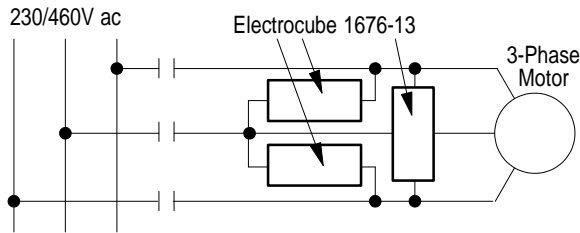

For 3-phase apparatus, a suppressor is needed across each phase

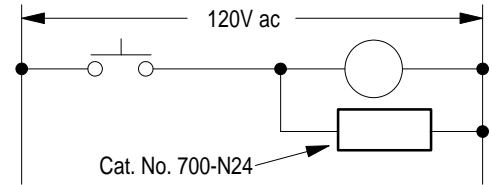

For small apparatus (relays, solenoids, and motor starters up to size 1)

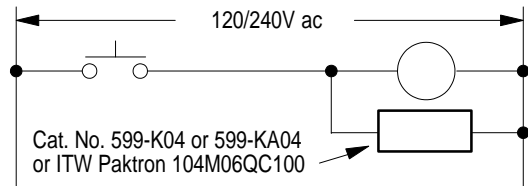

For large apparatus (contacts up to size 5)

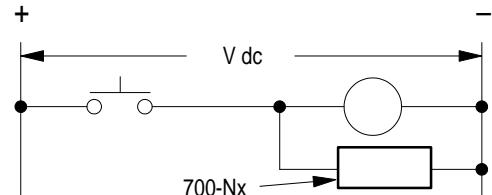

For dc relays

12057

**Table C**  
**Allen-Bradley Suppressors**

Allen-Bradley Equipment	Coil Voltage	Allen-Bradley Suppressor
Bulletin 509 motor starter	120V ac	599-K04
	240V ac	599-KA04
Bulletin 100 contactor	120V ac	199-FSMA1 <sup>1</sup>
	240V ac	199-FSMA2 <sup>1</sup>
Bulletin 709 motor starter	120V ac	1401-N10 <sup>1</sup>
Bulletin 700 type R or RM relays	ac coil	None required
Bulletin 700 type R relay	12V dc	700-N22
	24V dc	700-N10
	48V dc	700-N16
	115 – 125V dc	700-N11
	230 – 250V dc	700-N12
Bulletin 700 type RM relay	12V dc	700-N28
	24V dc	700-N113
	48V dc	700-N17
	115 – 125V dc	700-N14
	230 – 250V dc	700-N15
Bulletin 700 type N, P, or PK relays	150V max ac or dc	700-N5 or 700-N24 <sup>1</sup>
Miscellaneous electromagnetic devices limited of 35 sealed VA,		

<sup>1</sup> Not recommended for use with 1746 and 1747 triac outputs, because they could cause damage to triacs. For suppression of 1746 and 1747 triac outputs, use varistors instead.

Surge-suppressors are usually most effective when connected at the inductive loads. They are still usable when connected at the switching devices; however, this may be less effective because the wires connecting the switching devices to the inductive loads act as antennas that radiate emi. You can see the effectiveness of a particular suppressor by using an oscilloscope to observe the voltage waveform on the line.

## Ferrite Beads

Ferrite beads can provide additional suppression of transient emi. Fair-Rite Products Corporation manufactures a ferrite bead (part number 2643626502) which can be slipped over category-2 and -3 conductors. You can secure them with heat-shrink tubing or tie-wraps. With a ferrite bead located near the end of a cable (or cable segment in the case of a daisy-chain or dropline configuration) transient emi induced onto the cable can be suppressed by the bead before it enters the equipment connected to the end of the cable.

## Enclosure Lighting

Fluorescent lamps are also sources of emi. If you must use fluorescent lamps inside an enclosure, the following precautions may help guard against emi problems from this source as shown in Figure 12:

- install a shielding grid over the lamp
- use shielded cable between the lamp and its switch
- use a metal-encased switch
- install a filter between the switch and the power line, or shield the power-line cable

**Figure 12**  
Installation Requirements for Suppressing Noise from  
Fluorescent Lamps Inside an Enclosure

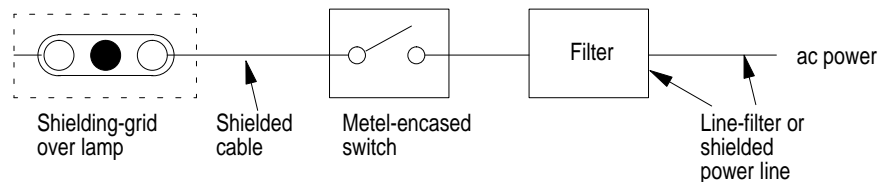

12619-1

## Avoiding Unintentional Momentary Turn-on of Outputs

Unintentional turn-on of outputs as the power source is connected or disconnected, even if momentary, can result in injury to personnel as well as damage to equipment. The danger is greater with fast-response actuators. You can help minimize the probability of unintentional momentary turn-on of ac and dc circuits by following each of these guidelines according to your specific application:

- follow the surge-suppression guidelines in this publication
- follow the bonding and grounding guidelines in this publication
- do not unnecessarily disconnect the power source from output circuits
- where possible, turn off all outputs before using CRM contacts to interrupt the output circuit power source
- hold off all outputs anytime the CRM contacts are open to be certain that they are off as power is reconnected

Even if unintentional momentary turn-on does occur, the effects can be minimized if:

- actuators have a home position, i.e. defined by a spring return
- for latching actuators, in the ladder logic, use non-retentive energize (OTE) instructions with hold-in (seal-in) paths to maintain the established position until power turn-off and leave outputs off initially at power turn-on
- each input or other load device connected to an output has an input-filter time constant no lower than necessary for the application

After designing and installing your system following these guidelines to minimize unintentional momentary turn-on and any effects thereof, test the system by de-energizing and the re-energizing the CRM relay (Figures 7 and 8).

## Related Publications

For additional information regarding wiring and grounding guidelines, refer to:

- Publication Index (Allen-Bradley publication SD499) — this lists all current Automation Group publications.
- Application Considerations for Solid-State Controls (Allen-Bradley publication SGI-1.1) — this is an aid to the user of solid-state controls who has considerable familiarity with relay-type controls but may have limited electronic experience and knowledge.

- National Electrical Code (ANSI/NFPA 70) — Article 250 of this code provides information about the types and sizes of conductors and methods for safely grounding electrical equipment and components. Articles 725-5, 725-15, 725-52, and 800-52 restrict the placement of different types of conductors in a composite cable, a raceway, or a cable tray.
- IEEE Recommended Practice for Grounding of Industrial and Commercial Power Systems (IEEE Std 142-1991)
- Grounding for the Control of EMI (by Hugh W. Denny — publisher, Don White Consultants Inc., 1973)
- Electromagnetic Interference and Compatibility, Volume 3 (by R.J. White — publisher, Don White Consultants, Inc., 1981)
- Military Handbook 419, “Grounding, Bonding, and Shielding for Electronic Equipment and Facilities”
- IEEE Guide for the Installation of Electrical Equipment to Minimize Electrical Noise Inputs to Controllers from External Sources (IEEE Std 518-1982)
- IEEE Recommended Practice for Powering and Grounding Sensitive Electronic Equipment (IEEE Std 1100-1992)

DH+, and FLEX I/O are trademarks of Rockwell Automation.

ControlNet is a trademark of ControlNet International.

DevicNet is a trademark of Open DeviceNet Vendor Association.



Allen-Bradley, a Rockwell Automation Business, has been helping its customers improve productivity and quality for more than 90 years. We design, manufacture and support a broad range of automation products worldwide. They include logic processors, power and motion control devices, operator interfaces, sensors and a variety of software. Rockwell is one of the world's leading technology companies.

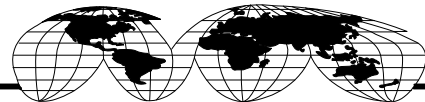

## Worldwide representation.

Argentina • Australia • Austria • Bahrain • Belgium • Brazil • Bulgaria • Canada • Chile • China, PRC • Colombia • Costa Rica • Croatia • Cyprus • Czech Republic • Denmark • Ecuador • Egypt • El Salvador • Finland • France • Germany • Greece • Guatemala • Honduras • Hong Kong • Hungary • Iceland • India • Indonesia • Ireland • Israel • Italy • Jamaica • Japan • Jordan • Korea • Kuwait • Lebanon • Malaysia • Mexico • Netherlands • New Zealand • Norway • Pakistan • Peru • Philippines • Poland • Portugal • Puerto Rico • Qatar • Romania • Russia-CIS • Saudi Arabia • Singapore • Slovakia • Slovenia • South Africa, Republic • Spain • Sweden • Switzerland • Taiwan • Thailand • Turkey • United Arab Emirates • United Kingdom • United States • Uruguay • Venezuela • Yugoslavia

Allen-Bradley Headquarters, 1201 South Second Street, Milwaukee, WI 53204 USA, Tel: (1) 414 382-2000 Fax: (1) 414 382-4444