

# Installation Instructions

Original Instructions



**Allen-Bradley**

by ROCKWELL AUTOMATION

## ControlLogix High-speed Counter Module

Catalog Number 1756-HSC

Topic	Page
Summary of Changes	1
Product Advisories	3
Install the Module	5
Key the Removable Terminal Block	5
Wire the Module	6
Wire Terminations	7
Assemble the RTB and Housing	11
Install the Removable Terminal Block	11
Remove the Removable Terminal Block	12
Remove the Module from the Chassis	12
Specifications	13
Additional Resources	14

The high-speed counter module performs high-speed counting for industrial applications. The 1756-HSC module counts pulses by using a Counter or Frequency operational mode. The counts are presented as either 'accumulated count' or 'frequency' depending on the mode that is configured for the module. See the *ControlLogix® High-Speed Counter Module User Manual*, publication [1756-UM007](#), for details.

### Summary of Changes

Topic	Page
Updated UK and European Hazardous Location Approval	3
Updated IEC Hazardous Location Approval	3
Updated Special Conditions for Safe Use	3
Added information regarding how to Wire an External Filter on Field Side DC Input for Marine Application	10



**ATTENTION:** Read this document and the documents listed in the Additional Resources section about installation, configuration and operation of this equipment before you install, configure, operate or maintain this product. Users are required to familiarize themselves with installation and wiring instructions in addition to requirements of all applicable codes, laws, and standards.

Activities including installation, adjustments, putting into service, use, assembly, disassembly, and maintenance are required to be carried out by suitably trained personnel in accordance with applicable code of practice. If this equipment is used in a manner not specified by the manufacturer, the protection provided by the equipment may be impaired.

注意：在安装、配置、操作和维护本产品前，请阅读本文档以及“其他资源”部分列出的有关设备安装、配置和操作的相应文档。除了所有适用规范、法律和标准的相关要求之外，用户还必须熟悉安装和接线说明。

安装、调整、投运、使用、组装、拆卸和维护等各项操作必须由经过适当训练的专业人员按照适用的操作规范实施。

如果未按照制造商指定的方式使用该设备，则可能会损害设备提供的保护。

**ATENCIÓN:** Antes de instalar, configurar, poner en funcionamiento o realizar el mantenimiento de este producto, lea este documento y los documentos listados en la sección Recursos adicionales acerca de la instalación, configuración y operación de este equipo. Los usuarios deben familiarizarse con las instrucciones de instalación y cableado y con los requisitos de todos los códigos, leyes y estándares vigentes.

El personal debidamente capacitado debe realizar las actividades relacionadas a la instalación, ajustes, puesta en servicio, uso, ensamblaje, desensamblaje y mantenimiento de conformidad con el código de práctica aplicable. Si este equipo se usa de una manera no especificada por el fabricante, la protección provista por el equipo puede resultar afectada.

**ATENÇÃO:** Leia este e os demais documentos sobre instalação, configuração e operação do equipamento que estão na seção Recursos adicionais antes de instalar, configurar, operar ou manter este produto. Os usuários devem se familiarizar com as instruções de instalação e fiação além das especificações para todos os códigos, leis e normas aplicáveis.

É necessário que as atividades, incluindo instalação, ajustes, colocação em serviço, utilização, montagem, desmontagem e manutenção sejam realizadas por pessoal qualificado e especializado, de acordo com o código de prática aplicável.

Caso este equipamento seja utilizado de maneira não estabelecida pelo fabricante, a proteção fornecida pelo equipamento pode ficar prejudicada.

**ВНИМАНИЕ:** Перед тем как устанавливать, настраивать, эксплуатировать или обслуживать данное оборудование, прочитайте этот документ и документы, перечисленные в разделе «Дополнительные ресурсы». В этих документах изложены сведения об установке, настройке и эксплуатации данного оборудования. Пользователи обязаны ознакомиться с инструкциями по установке и прокладке соединений, а также с требованиями всех применимых норм, законов и стандартов.

Все действия, включая установку, наладку, ввод в эксплуатацию, использование, сборку, разборку и техническое обслуживание, должны выполняться обученным персоналом в соответствии с применимыми нормами и правилами.

Если оборудование используется не предусмотренным производителем образом, защита оборудования может быть нарушена.

注意：本製品を設置、構成、稼働または保守する前に、本書および本機器の設置、設定、操作についての参考資料の該当箇所に記載されている文書を目を通してください。ユーザは、すべての該当する条例、法律、規格の要件に加えて、設置および配線の手順に習熟している必要があります。

設置調整、運転の開始、使用、組立て、解体、保守を含む諸作業は、該当する実施規則に従って訓練を受けた適切な作業員が実行する必要があります。

本機器が製造メーカーにより指定されていない方法で使用されている場合、機器により提供されている保護が損なわれる恐れがあります。

**ACHTUNG:** Lesen Sie dieses Dokument und die im Abschnitt „Weitere Informationen“ aufgeführten Dokumente, die Informationen zu Installation, Konfiguration und Bedienung dieses Produkts enthalten, bevor Sie dieses Produkt installieren, konfigurieren, bedienen oder warten. Anwender müssen sich neben den Bestimmungen aller anwendbaren Vorschriften, Gesetze und Normen zusätzlich mit den Installations- und Verdrahtungsanweisungen vertraut machen.

Arbeiten im Rahmen der Installation, Anpassung, Inbetriebnahme, Verwendung, Montage, Demontage oder Instandhaltung dürfen nur durch ausreichend geschulte Mitarbeiter und in Übereinstimmung mit den anwendbaren Ausführungsvorschriften vorgenommen werden.

Wenn das Gerät in einer Weise verwendet wird, die vom Hersteller nicht vorgesehen ist, kann die Schutzfunktion beeinträchtigt sein.

**ATTENTION:** Lisez ce document et les documents listés dans la section Ressources complémentaires relatifs à l'installation, la configuration et le fonctionnement de cet équipement avant d'installer, configurer, utiliser ou entretenir ce produit. Les utilisateurs doivent se familiariser avec les instructions d'installation et de câblage en plus des exigences relatives aux codes, lois et normes en vigueur.

Les activités relatives à l'installation, le réglage, la mise en service, l'utilisation, l'assemblage, le démontage et l'entretien doivent être réalisées par des personnes formées selon le code de pratique en vigueur.

Si cet équipement est utilisé d'une façon qui n'a pas été définie par le fabricant, la protection fournie par l'équipement peut être compromise.

주의：본 제품 설치, 설정, 작동 또는 유지 보수하기 전에 본 문서를 포함하여 설치, 설정 및 작동에 관한 참고 자료 섹션의 문서들을 반드시 읽고 숙지하십시오. 사용자는 모든 관련 규정, 법규 및 표준에서 요구하는 사항에 대해 반드시 설치 및 배선 지침을 숙지해야 합니다.

설치, 조정, 가동, 사용, 조립, 분해, 유지보수 등 모든 작업은 관련 규정에 따라 적절한 교육을 받은 사용자를 통해서만 수행해야 합니다.

본 장비를 제조사가 명시하지 않은 방법으로 사용하면 장비의 보호 기능이 손상될 수 있습니다.

**ATTENZIONE:** Prima di installare, configurare ed utilizzare il prodotto, o effettuare interventi di manutenzione su di esso, leggere il presente documento ed i documenti elencati nella sezione "Altre risorse", riguardanti l'installazione, la configurazione ed il funzionamento dell'apparecchiatura. Gli utenti devono leggere e comprendere le istruzioni di installazione e cablaggio, oltre ai requisiti previsti dalle leggi, codici e standard applicabili.

Le attività come installazione, regolazioni, utilizzo, assemblaggio, disassemblaggio e manutenzione devono essere svolte da personale adeguatamente addestrato, nel rispetto delle procedure previste.

Qualora l'apparecchio venga utilizzato con modalità diverse da quanto previsto dal produttore, la sua funzione di protezione potrebbe venire compromessa.

**DİKKAT:** Bu ürünün kurulumu, yapılandırılması, işletilmesi veya bakımı öncesinde bu dokümanı ve bu ekipmanın kurulumu, yapılandırılması ve işletimi ile ilgili ilave Kaynaklar bölümünde yer listelenmiş dokümanları okuyun. Kullanıcılar yürürlükteki tüm yönetmelikler, yasalar ve standartların gereksinimlerine ek olarak kurulum ve kablolarla talimatlarını da öğrenmek zorundadır. Kurulum, ayarlama, hizmete alma, kullanma, parçaları birleştirme, parçaları sökme ve bakım gibi aktiviteler sadece uygun eğitimleri almış kişiler tarafından yürürlükteki uygulamaya yönetmeliklerine uygun şekilde yapılabilir.

Bu ekipman üretici tarafından belirlenmiş amacın dışında kullanılırsa, ekipman tarafından sağlanan koruma bozulabilir.

注意事項：在安装、設定、操作或維護本產品前，請先閱讀此文件以及列於「其他資源」章節中有關安裝、設定與操作此設備的文件。使用者必須熟悉安裝和配線指示，並符合所有法規、法律和標準要求。

包括安裝、調整、交付使用、使用、組裝、拆卸和維護等動作都必須交由已經過適當訓練的人員進行，以符合適用的實作法規。

如果將設備用於非製造商指定的用途時，可能會造成設備所提供的保護功能受損。

**POZOR:** Než začnete instalovat, konfigurovat či provozovat tento výrobek nebo provádět jeho údržbu, přečtěte si tento dokument a dokumenty uvedené v části Dodatečné zdroje ohledně instalace, konfigurace a provozu tohoto zařízení. Uživatelé se musejí vedle požadavků všech relevantních vyhlášek, zákonů a norem nutně seznámit také s pokyny pro instalaci a elektrické zapojení.

Činnosti zahrnující instalaci, nastavení, uvedení do provozu, užívání, montáž, demontáž a údržbu musí vykonávat vhodně proškolený personál v souladu s příslušnými prováděcími předpisy. Pokud se toto zařízení používá způsobem neodpovídajícím specifikaci výrobce, může být narušena ochrana, kterou toto zařízení poskytuje.

**UWAGA:** Przed instalacją, konfiguracją, użytkowaniem lub konserwacją tego produktu należy przeczytać niniejszy dokument oraz wszystkie dokumenty wymienione w sekcji Dodatkowe źródła omawiające instalację, konfigurację i procedury użytkowania tego urządzenia. Użytkownicy mają obowiązek zapoznać się z instrukcjami dotyczącymi instalacji oraz oprzewodowania, jak również z obowiązującymi kodeksami, prawem i normami.

Działania obejmujące instalację, regulację, przekazanie do użytkowania, użytkowanie, montaż, demontaż oraz konserwację muszą być wykonywane przez odpowiednio przeszkolony personel zgodnie z obowiązującym kodeksem postępowania.

Jeśli urządzenie jest użytkowane w sposób inny niż określony przez producenta, zabezpieczenie zapewniane przez urządzenie może zostać ograniczone.

**OBST!** Läs detta dokument samt dokumentet, som står listat i avsnittet Övriga resurser, om installation, konfigurering och drift av denna utrustning innan du installerar, konfigurerar eller börjar använda eller utföra underhållsarbete på produkten. Användare måste bekanta sig med instruktioner för installation och kabeldragning, förutom krav enligt gällande koder, lagar och standarder.

Åtgärder som installation, justering, service, användning, montering, demontering och underhållsarbete måste utföras av personal med lämplig utbildning enligt lämpligt bruk.

Om denna utrustning används på ett sätt som inte anges av tillverkaren kan det hända att utrustningens skyddsanordningar försätts ur funktion.



**LET OP:** Lees dit document en de documenten die genoemd worden in de paragraaf Aanvullende informatie over de installatie, configuratie en bediening van deze apparatuur voordat u dit product installeert, configureert, bedient of onderhoudt. Gebruikers moeten zich vertrouwd maken met de installatie en de bedravingsinstructies, naast de vereisten van alle toepasselijke regels, wetten en normen.

Activiteiten zoals het installeren, afstellen, in gebruik stellen, gebruiken, monteren, demonteren en het uitvoeren van onderhoud mogen uitsluitend worden uitgevoerd door hiervoor opgeleide personeel en in overeenstemming met de geldende praktijkregels.

Indien de apparatuur wordt gebruikt op een wijze die niet is gespecificeerd door de fabrikant, dan bestaat het gevaar dat de beveiliging van de apparatuur niet goed werkt.

## Product Advisories

### North American Hazardous Location Approval

The following information applies when operating this equipment in hazardous locations.	Informations sur l'utilisation de cet équipement en environnements dangereux.
<p>Products marked "CL I, DIV 2, GP A, B, C, D" are suitable for use in Class I Division 2 Groups A, B, C, D, Hazardous Locations and nonhazardous locations only. Each product is supplied with markings on the rating nameplate indicating the hazardous location temperature code. When combining products within a system, the most adverse temperature code (lowest "T" number) may be used to help determine the overall temperature code of the system. Combinations of equipment in your system are subject to investigation by the local Authority Having Jurisdiction at the time of installation.</p>	<p>Les produits marqués "CL I, DIV 2, GP A, B, C, D" ne conviennent qu'à une utilisation en environnements de Classe I Division 2 Groupes A, B, C, D dangereux et non dangereux. Chaque produit est livré avec des marquages sur sa plaque d'identification qui indiquent le code de température pour les environnements dangereux. Lorsque plusieurs produits sont combinés dans un système, le code de température le plus défavorable (code de température le plus faible) peut être utilisé pour déterminer le code de température global du système. Les combinaisons d'équipements dans le système sont sujettes à inspection par les autorités locales qualifiées au moment de l'installation.</p>
 <p><b>WARNING:</b> <b>Explosion Hazard -</b></p> <ul style="list-style-type: none"> <li>Do not disconnect equipment unless power has been removed or the area is known to be nonhazardous.</li> <li>Do not disconnect connections to this equipment unless power has been removed or the area is known to be nonhazardous. Secure any external connections that mate to this equipment by using screws, sliding latches, threaded connectors, or other means provided with this product.</li> <li>Substitution of components may impair suitability for Class I, Division 2.</li> <li>If this product contains batteries, they must only be changed in an area known to be nonhazardous.</li> </ul>	 <p><b>AVERTISSEMENT:</b> <b>Risque d'Explosion -</b></p> <ul style="list-style-type: none"> <li>Couper le courant ou s'assurer que l'environnement est classé non dangereux avant de débrancher l'équipement.</li> <li>Couper le courant ou s'assurer que l'environnement est classé non dangereux avant de débrancher les connecteurs. Fixer tous les connecteurs externes reliés à cet équipement à l'aide de vis, loquets coulissants, connecteurs filetés ou autres moyens fournis avec ce produit.</li> <li>La substitution de composants peut rendre cet équipement inadapté à une utilisation en environnement de Classe I, Division 2.</li> <li>S'assurer que l'environnement est classé non dangereux avant de changer les piles.</li> </ul>

### UK and European Hazardous Location Approval

<p>The following applies to products marked , II 3 G. Such modules:</p> <ul style="list-style-type: none"> <li>Are Equipment Group II, Equipment Category 3, and comply with the Essential Health and Safety Requirements relating to the design and construction of such equipment given in Annex II to EU Directive 2014/34/EU and Schedule 1 of the UKEX Regulation 2016 No. 1107. See the UKEX and EU Declaration of Conformity at <a href="http://rok.auto/certifications">rok.auto/certifications</a> for details.</li> <li>The type of protection is &lt;Ex ec IIC T4 Gc&gt; Equipment protection by increased safety "e".</li> <li>Equipment protection by increased safety "e", reference certificate number DEMK020ATEX2340X and UL220UKEX2332X.</li> <li>Are intended for use in areas in which explosive atmospheres caused by gases, vapors, mists, or air are unlikely to occur, or are likely to occur only infrequently and for short periods. Such locations correspond to Zone 2 classification according to UKEX Regulation 2016 No. 1107 and ATEX directive 2014/34/EU.</li> </ul>
---

### IEC Hazardous Location Approval

<p>The following applies to products with IECEx certification. Such products:</p> <ul style="list-style-type: none"> <li>Are intended for use in areas in which explosive atmospheres caused by gases, vapors, mists, or air are unlikely to occur, or are likely to occur only infrequently and for short periods. Such locations correspond to Zone 2 classification.</li> <li>The type of protection is &lt;Ex ec IIC T4 Gc&gt;.</li> <li>IECEx certificate number IECEx UL 20.0013X.</li> </ul>
---

### Special Conditions for Safe Use

 <p><b>WARNING:</b></p> <ul style="list-style-type: none"> <li>This equipment is not resistant to sunlight or other sources of UV radiation.</li> <li>This equipment shall be mounted in an UKEX/ATEX/IECEx Zone 2 certified enclosure with a minimum ingress protection rating of at least IP54 (in accordance with EN/IEC 60079-0) and used in an environment of not more than Pollution Degree 2 (as defined in EN/IEC 60664-1) when applied in Zone 2 environments. The enclosure must be accessible only by the use of a tool.</li> <li>This equipment shall be used within its specified ratings defined by Rockwell Automation.</li> <li>Transient protection shall be provided that is set at a level not exceeding 140% of the peak rated voltage at the supply terminals to the equipment.</li> <li>The instructions in the user manual shall be observed.</li> <li>This equipment must be used only with UKEX/ATEX/IECEx certified Rockwell Automation backplanes.</li> <li>Secure any external connections that mate to this equipment by using screws, sliding latches, threaded connectors, or other means provided with this product.</li> <li>Do not disconnect equipment unless power has been removed or the area is known to be nonhazardous.</li> <li>The USB port is intended for temporary local programming purposes only and not intended for permanent connection. Do not use the USB port in hazardous locations.</li> </ul>
---

## Environment and Enclosure

---



**ATTENTION:** This equipment is intended for use in a Pollution Degree 2 industrial environment, in overvoltage Category II applications (as defined in IEC/EN 60664-1), at altitudes up to 2000 m (6562 ft) without derating. This equipment is considered Group 1, Class A industrial equipment according to IEC/CISPR 11. Without appropriate precautions, there may be difficulties with electromagnetic compatibility in residential and other environments due to conducted and radiated disturbances.

This equipment is supplied as open-type equipment. It must be mounted within an enclosure that is suitably designed for those specific environmental conditions that will be present and appropriately designed to help prevent personal injury resulting from accessibility to live parts. The enclosure must have suitable flame-retardant properties to help prevent or minimize the spread of flame, complying with a flame spread rating of 5VA, V2, V1, V0 (or equivalent) if nonmetallic. The interior of the enclosure must be accessible only by the use of a tool. Subsequent sections of this publication may contain additional information regarding specific enclosure type ratings that are required to comply with certain product safety certifications. In addition to this publication, see the following:

- *Industrial Automation Wiring and Grounding Guidelines*, publication [1770-4.1](#), for more installation requirements.
  - NEMA Standard 250 and IEC/EN 60529, as applicable, for explanations of the degrees of protection provided by enclosures.
- 

## Prevent Electrostatic Discharge

---



**ATTENTION:**

This equipment is sensitive to electrostatic discharge, which can cause internal damage and affect normal operation. Follow these guidelines when you handle this equipment:

- Touch a grounded object to discharge potential static.
  - Wear an approved grounding wriststrap.
  - Do not touch connectors or pins on component boards.
  - Do not touch circuit components inside the equipment
  - Use a static-safe workstation, if available.
  - Store the equipment in appropriate static-safe packaging when not in use.
-

## Install the Module

You can install or remove the module while chassis power is applied.



**WARNING:** When you insert or remove the module while backplane power is on, an electric arc can occur. This could cause an explosion in hazardous location installations. Be sure that power is removed or the area is nonhazardous before proceeding. Repeated electrical arcing causes excessive wear to contacts on both the module and its mating connector. Worn contacts may create electrical resistance that can affect module operation.



**WARNING:** When you connect or disconnect the removable terminal block (RTB) with field-side power applied, an electric arc can occur. This could cause an explosion in hazardous location installations.

1. Align the circuit board with the top and bottom chassis guides, as shown.

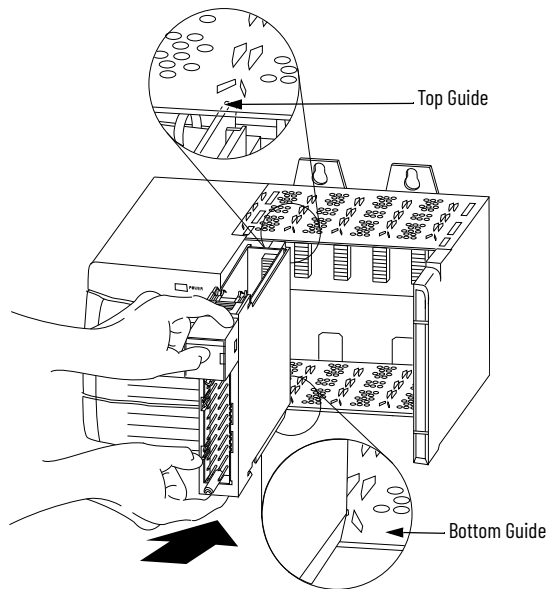

2. Slide the module into the chassis until the module's top and bottom locking tabs click.

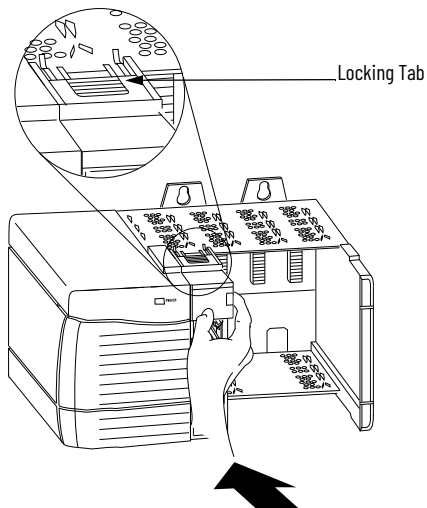

## Key the Removable Terminal Block

We recommend that you key the RTB to help prevent inadvertently connecting the incorrect RTB to your module.

When the RTB mounts onto the module, keying positions match up. For example, if you place a U-shaped keying band in slot 4 on the module, you cannot place a wedge-shaped tab in slot 4 on the RTB or your RTB will not mount on the module.

1. Insert the U-shaped band with the longer side near the terminals, and push the band on the module until it snaps into place.

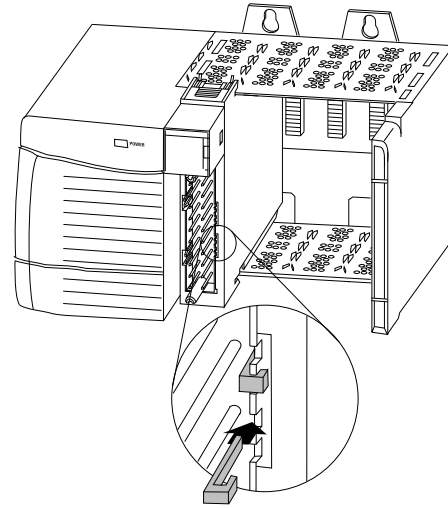

2. Key the RTB in positions that correspond to unkeyed module positions.
3. Insert the wedge-shaped tab on the RTB with the rounded edge first.
4. Push the tab onto the RTB until it stops.

**IMPORTANT** When keying your RTB and module, you must begin with a wedge-shaped tab in slot 6 or 7.

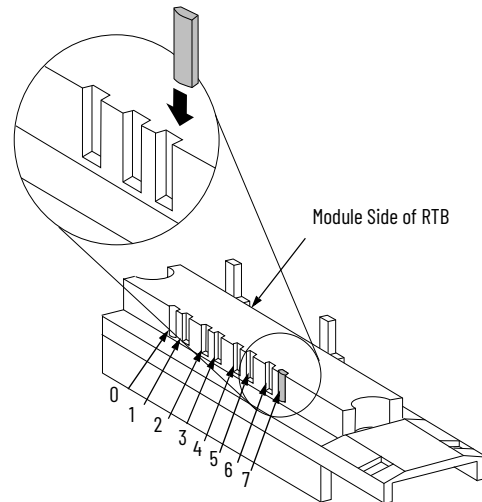

## Wire the Module

You can use an RTB to connect the wiring to your module. We recommend Belden 8761 cable for most applications. The RTB terminations can accommodate 0.25...2.5 mm<sup>2</sup> (22...14 AWG) shielded wire. Connect the ground wiring before wiring the RTB.

Before wiring the module, adhere to the following wiring guidelines.



**WARNING:** If you connect or disconnect the wiring while the field-side power is on, an electric arc can occur. This could cause an explosion in hazardous location installations. Be sure that power is removed or the area is nonhazardous before proceeding.



**WARNING:** If multiple power sources are used, do not exceed the specified isolation voltage.



**WARNING:** When using the 1756-TBCH RTB, do not wire more than two 0.25...2.5 mm<sup>2</sup> (22...14 AWG) conductors on any single terminal. Use only the same size wires with no intermixing of solid and stranded wire types. When using the 1756-TBS6H RTB, do not wire multiple conductors on any single terminal.

Follow these directions to ground the wiring to the RTB.

**IMPORTANT** We recommend you ground the drain wire at the field-side. If you cannot ground at the field-side, ground at an earth ground on the chassis as shown below.

1. Remove a length of cable jacket from the connecting cables.
2. Pull the foil shield and bare the drain wire from the insulated wire.

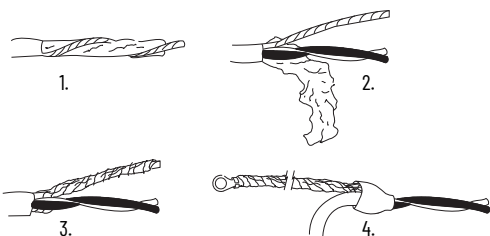

3. Twist the foil shield and the drain wire together to form one strand.
4. Attach a ground lug and apply heat shrink tubing to the exit area.
5. Connect the drain wire to a chassis mounting tab.

Use any chassis mounting tab that is designated as a functional signal ground. The functional earth ground symbol appears near the tab.

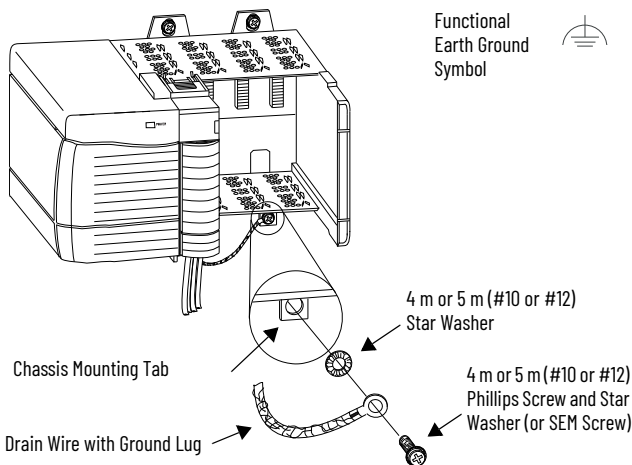

6. Connect the insulated wires to the field-side.

## Connect the Ungrounded End of the Cable

Follow these directions to connect the ungrounded end of the cable.

1. Cut the foil shield and the drain wire back to the cable casing and apply shrink wrap.
2. Connect the insulated wires to the RTB.

## Recommendations for Wiring Your RTB

We recommend that you follow these guidelines when wiring your RTB.

1. Begin wiring the RTB at the bottom terminals and move up.
2. Use a tie to secure the wires in the strain relief (bottom) area of the RTB.
3. Order and use an extended-depth housing (catalog number 1756-TBE) for applications that require heavy gauge wiring. Each RTB comes with a standard housing.

See Appendix D in [1756-UM007](#) for cable considerations.

You can use a cage-clamp RTB, catalog number 1756-TBCH, or a spring-clamp RTB, catalog number 1756-TBS6H.

### Wire a Cage-clamp RTB

1. Insert the wire into the terminal.
2. Turn the screw clockwise to close the terminal on the wire.

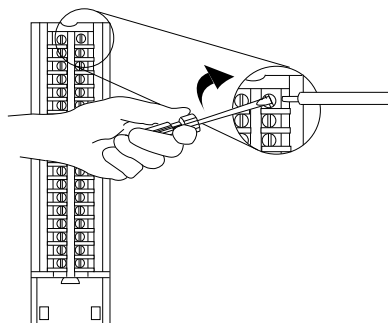

### Wire a Spring-clamp RTB

1. Insert the screwdriver into the outer hole of the RTB.
2. Insert the wire into the open terminal and remove the screwdriver.

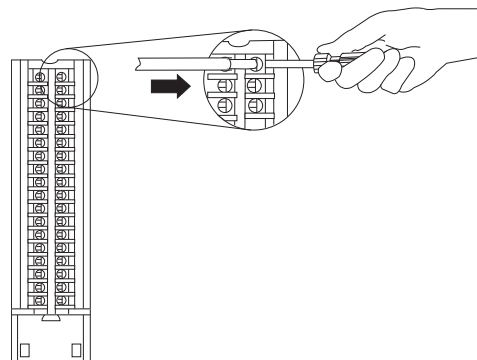

**ATTENTION:** The ControlLogix system has been agency certified using only the ControlLogix RTBs (catalog numbers 1756-TBCH and 1756-TBS6H). Any application that requires agency certification of the ControlLogix system using other wiring termination methods may require application-specific approval by the certifying agency.

## Wire Terminations

The following sections provide details about wiring terminations to specific products.

### Wire an Allen-Bradley 845 Incremental Encoder

Use the table and diagram to connect the 1756-HSC module to an Allen-Bradley® 845 incremental encoder.

Application	A1 Connections	B1 Connections	Z1 Connections
Differential Line Driver Output (40 mA)	White - A1 5V DC Black of white - A1 Return	Blue - B1 5V DC Black of blue - B1 Return	Green - Z1 5V DC Black of green - Z1 Return

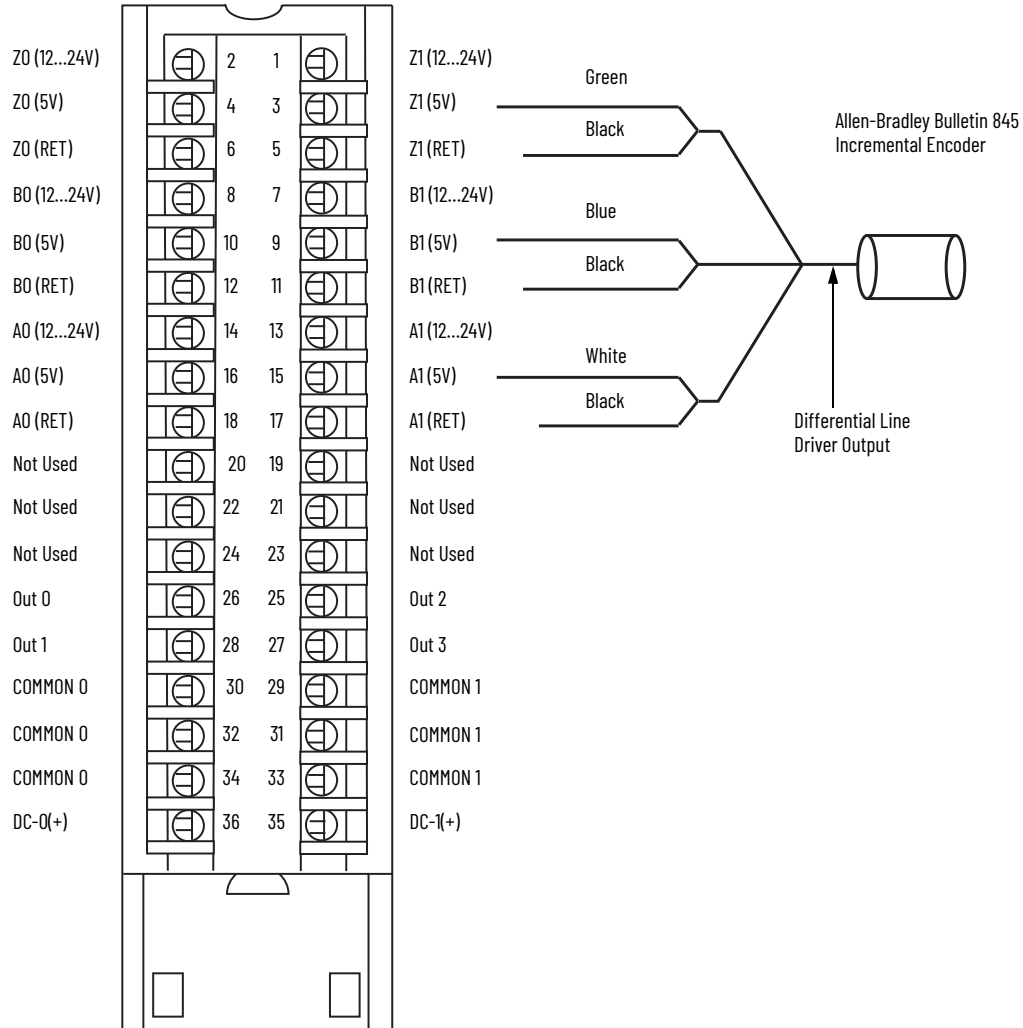

## Wire an Allen-Bradley Bulletin 872 3-Wire DC Proximity Sensor

Use the table and diagram to connect the 1756-HSC module to an Allen-Bradley 872 three-wire DC proximity sensor.

Application	A0 Connections	B0 Connections	Z0 Connections
PNP (Sourcing) N.O.	Black - A0 12...24V DC Blue, PS(-)-A0 Return	Jumper B0 12...24V DC to B0 Return	Jumper Z0 12...24V DC to Z0 Return

Allen-Bradley Bulletin 872  
3-Wire DC Proximity Sensor

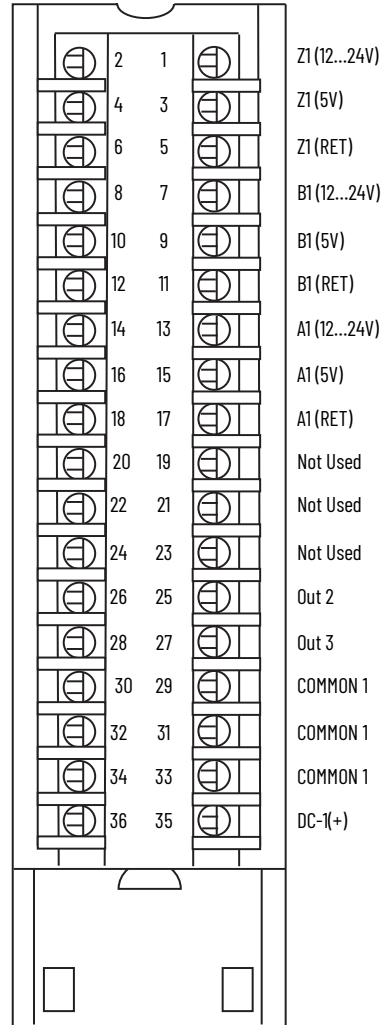
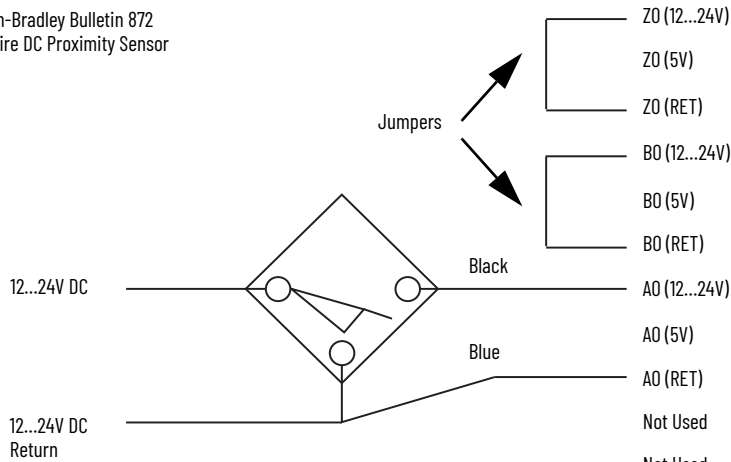

## Wire a PHOTOSWITCH Series 10,000 Photoelectric Sensor

Use the table and diagram to connect the wiring to a PHOTOSWITCH® series 10,000 photoelectric sensor.

Application	A1 Connections	B1 Connections	Z1 Connections
Any	Black - A1 12...24V DC Blue - A1 Return	Jumper B1 12...24V DC to B1 Return	White - Z1 12...24V DC Blue - Z1 Return

PHOTOSWITCH Series 10,000  
Photoelectric Sensor

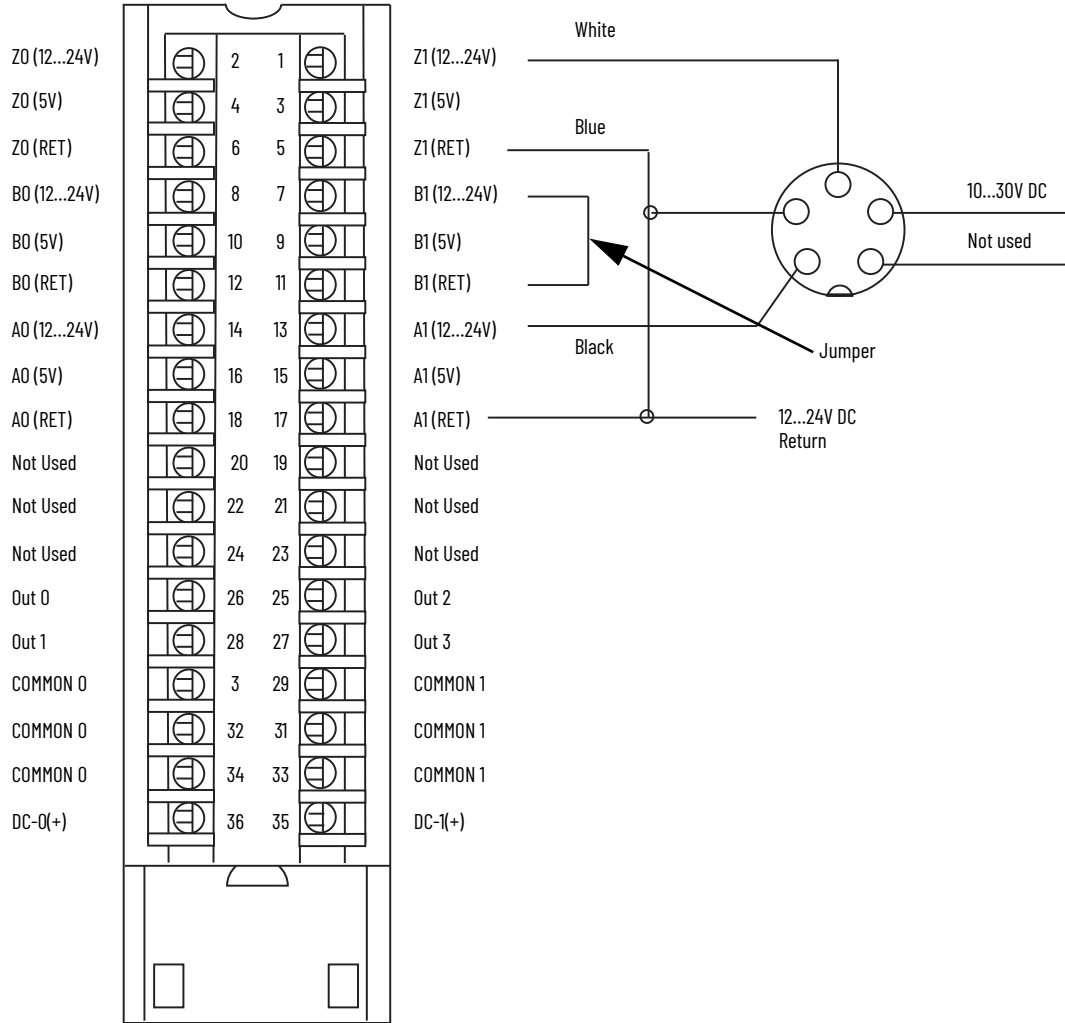

## Wire an External Filter on Field Side DC Input for Marine Application

Use the diagram to connect the 1756-HSC module to the recommended external filter for controlled field side DC input emissions in a Marine environment.

### Recommended External Filter

Manufacturer	Part	Part Number	Specifications
TE Connectivity	Corcom Single Phase Filter	20VSB1	Filter Current Rating (A): 20 Filter Mount Style : Flanged Input Termination Type : .250 in. FASTON Output Termination Type : .250 in. FASTON Leakage Current (Max)(120VAC, 60Hz) (mA): .22

TE Connectivity  
Corcom Single Phase Filter, 20VSB1

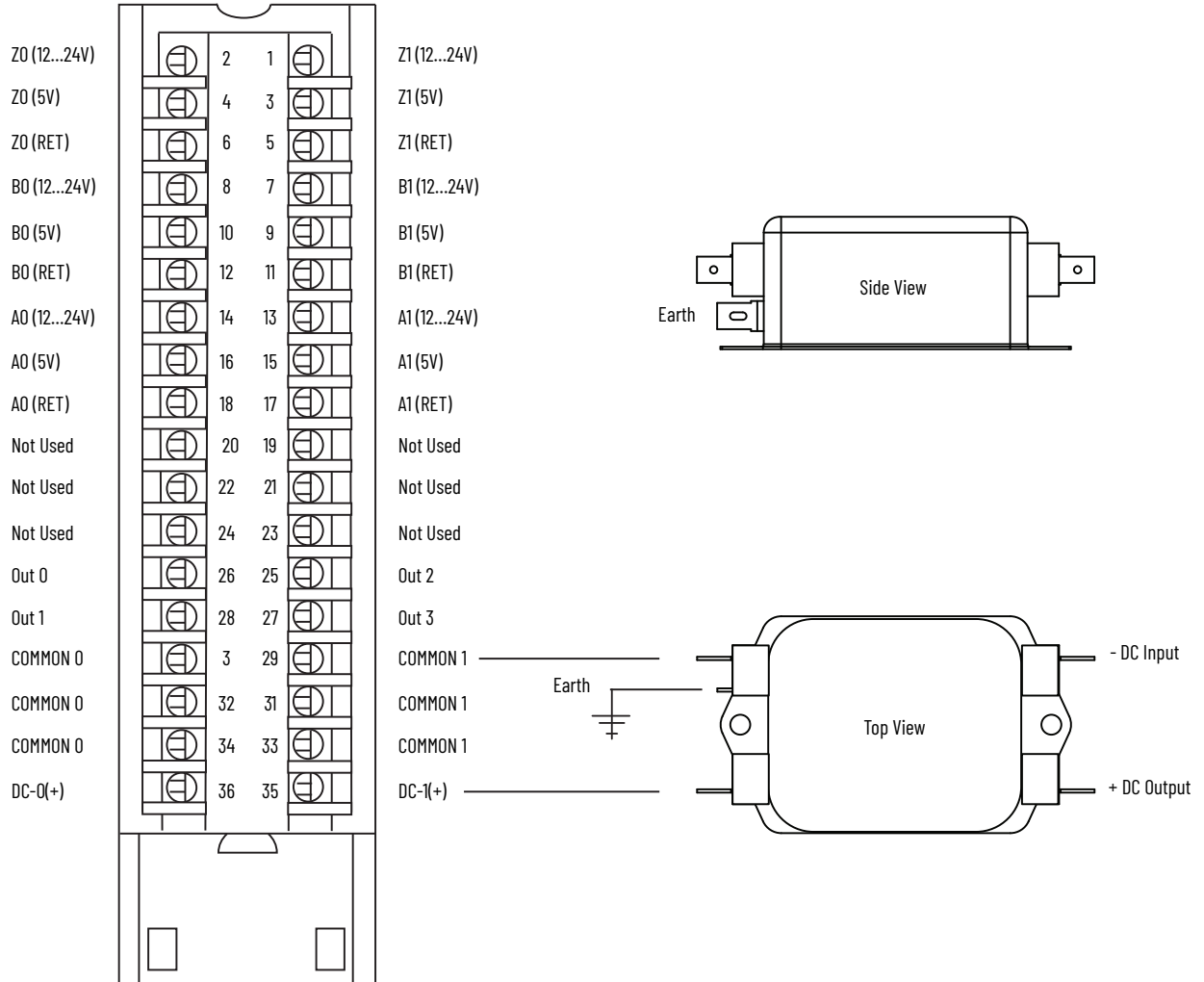

## Assemble the RTB and Housing

Removable housing covers the wired RTB to protect wiring connections when the RTB is seated on the module. This figure details the parts of the 1756-TBCH RTB.

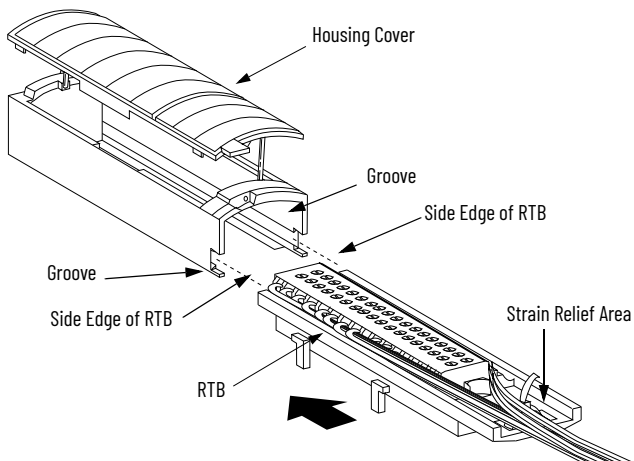

Follow these steps to attach the RTB to the housing.

1. Align the grooves at the bottom of each side of the housing with the side edges of the RTB.
2. Slide the RTB into the housing until it snaps into place.

**IMPORTANT** If additional wire routing space is required for your application, use the extended-depth housing, catalog number 1756-TBE.

## Install the Removable Terminal Block



**WARNING:** When you connect or disconnect the Removable Terminal Block (RTB) with field side power applied, an electric arc can occur. This could cause an explosion in hazardous location installations.

Be sure that power is removed or the area is nonhazardous before proceeding.

Before installing the RTB, verify the following:

- the field-side wiring of the RTB has been completed.
- the RTB housing is snapped into place on the RTB.
- the RTB housing door is closed.
- the locking tab at the top of the module is unlocked.

Follow these steps to install the RTB onto the module to connect the wiring.

1. Align the top, bottom, and left guides of the RTB with those on the module.

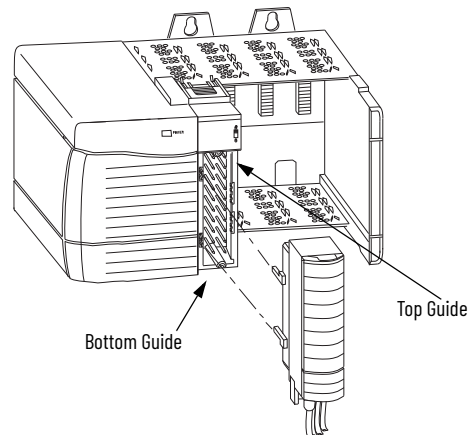

2. Press quickly and evenly to seat the RTB on the module until the latches snap into place.
3. Slide the locking tab down to lock the RTB onto the module.

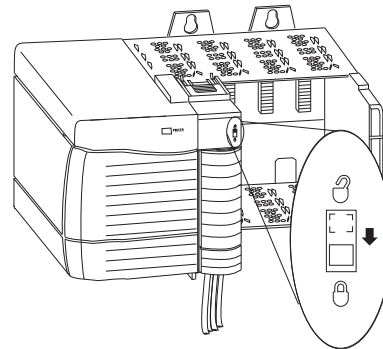

## Remove the Removable Terminal Block

If you must remove the module from the chassis, you must first remove the RTB from the module. Follow these steps to remove the RTB.



**WARNING:** When you connect or disconnect the Removable Terminal Block (RTB) with field side power applied, an electric arc can occur. This could cause an explosion in hazardous location installations. Be sure that power is removed or the area is nonhazardous before proceeding.

1. Unlock the locking tab at the top of the module.
2. Open the RTB door by using the bottom tab.
3. Hold the spot marked PULL HERE and pull the RTB off the module.

**IMPORTANT** Do not wrap your fingers around the entire door. A shock hazard exists.

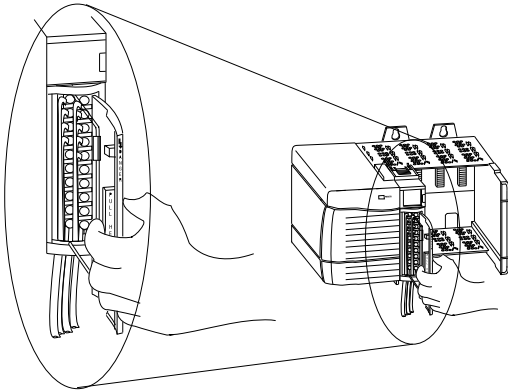

## Remove the Module from the Chassis

Follow these steps to remove a module from its chassis.



**WARNING:** When you insert or remove the module while backplane power is on, an electric arc can occur. This could cause an explosion in hazardous location installations. Be sure that power is removed or the area is nonhazardous before proceeding. Repeated electrical arcing causes excessive wear to contacts on both the module and its mating connector. Worn contacts may create electrical resistance that can affect module operation.

1. Push in the top and bottom locking tabs.

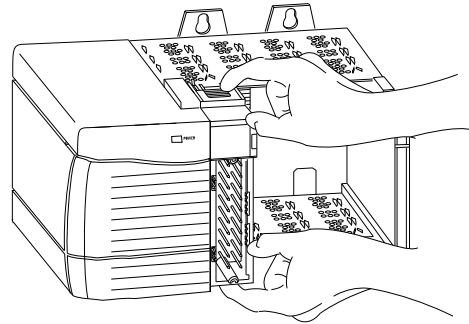

2. Pull the module out of the chassis.

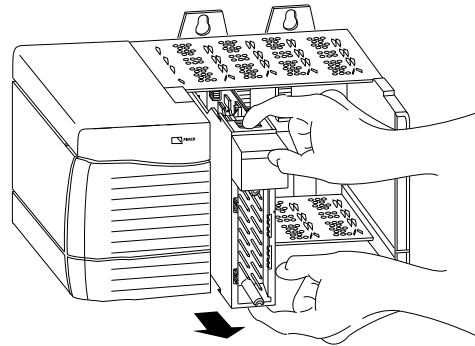

## Specifications

This table lists a subset of the module specifications. For a list of all specifications, see the *1756 ControlLogix I/O Specifications Technical Data*, publication [1756-TD002](#).

Attribute	1756-HSC
Temperature, operating IEC 60068-2-1 (Test Ad, Operating Cold), IEC 60068-2-2 (Test Bd, Operating Dry Heat), IEC 60068-2-14 (Test Nb, Operating Thermal Shock)	$0\text{ }^{\circ}\text{C} \leq T_a \leq 60\text{ }^{\circ}\text{C}$ ( $32\text{ }^{\circ}\text{F} \leq T_a \leq 140\text{ }^{\circ}\text{F}$ )
Temperature, surrounding air, max	60 °C (140 °F)
Enclosure type	None (open-style)
Voltage and current ratings	
Operating voltage range, inputs	5V operation: 4.5...5.5V DC 12/24V operation: 10...26.4V DC <sup>(1)</sup>
Operating voltage range, outputs	5V operation: 4.5...5.5V DC 12/24V operation: 10...26.4V DC <sup>(1)</sup>
Backplane current draw at 5.1V	300 mA
Backplane current draw at 24V	3 mA
Total backplane dissipation	1.6 W
Total power dissipation, max	3.5 W @ 60 °C (140 °F)
Thermal dissipation	12 BTU/hr
Isolation voltage	250V (continuous), basic insulation type, input group-to-backplane 125V (continuous), basic insulation type, input group-to-input group
Number of counters	2
Inputs per counter	3 (A, B, Z for gate/reset)
Removable terminal block (RTB)	1756-TBCH 1756-TBS6H
Screw torque	0.5 N•m (4.4 lb•in)
Wire size	0.25...2.5 mm <sup>2</sup> (22...14 AWG) solid or stranded shielded copper wire that is rated at 75 °C (167 °F), or greater, 1.2 mm (3/64 in.) insulation max
Wiring category <sup>(2)</sup>	2 on signal ports; 1 on power ports
Temperature code	T4

(1) UL rating is 24V DC.

(2) Use this Conductor Category information to plan conductor routing. For more information, see *Industrial Automation Wiring and Grounding Guidelines*, publication [1770-4.1](#).

## Additional Resources

These documents contain additional information concerning related products from Rockwell Automation.

Resource	Description
1756 ControlLogix I/O Specifications Technical Data, publication <a href="#">1756-TD002</a>	Provides specification information for the ControlLogix I/O modules.
ControlLogix High Speed Counter Module User Manual, publication <a href="#">1756-UM007</a>	Provides detailed information about installation and use of the high-speed counter module.
Industrial Automation Wiring and Grounding Guidelines, publication <a href="#">1770-4.1</a>	Provides general guidelines for installing a Rockwell Automation industrial system.
Product Certifications website: <a href="http://rok.auto/certifications">rok.auto/certifications</a>	Provides declarations of conformity, certificates, and other certification details.

You can view or download publications at [rok.auto/literature](http://rok.auto/literature).

**Notes:**

# Rockwell Automation Support

Use these resources to access support information.

<b>Technical Support Center</b>	Find help with how-to videos, FAQs, chat, user forums, Knowledgebase, and product notification updates.	<a href="http://rok.auto/support">rok.auto/support</a>
<b>Local Technical Support Phone Numbers</b>	Locate the telephone number for your country.	<a href="http://rok.auto/phonesupport">rok.auto/phonesupport</a>
<b>Technical Documentation Center</b>	Quickly access and download technical specifications, installation instructions, and user manuals.	<a href="http://rok.auto/techdocs">rok.auto/techdocs</a>
<b>Literature Library</b>	Find installation instructions, manuals, brochures, and technical data publications.	<a href="http://rok.auto/literature">rok.auto/literature</a>
<b>Product Compatibility and Download Center (PCDC)</b>	Download firmware, associated files (such as AOP, EDS, and DTM), and access product release notes.	<a href="http://rok.auto/pcdc">rok.auto/pcdc</a>

## Documentation Feedback

Your comments help us serve your documentation needs better. If you have any suggestions on how to improve our content, complete the form at [rok.auto/docfeedback](http://rok.auto/docfeedback).





## Waste Electrical and Electronic Equipment (WEEE)



At the end of life, this equipment should be collected separately from any unsorted municipal waste.

Rockwell Automation maintains current product environmental compliance information on its website at [rok.auto/pec](http://rok.auto/pec).

Rockwell Otomasyon Ticaret A.Ş. Kar Plaza İş Merkezi E Blok Kat:6 34752 İçerenköy, İstanbul, Tel: +90 (216) 5698400 EEE Yönetmeliğine Uygundur

Connect with us.    

[rockwellautomation.com](http://rockwellautomation.com)

expanding human possibility®

AMERICAS: Rockwell Automation, 1201 South Second Street, Milwaukee, WI 53204-2496 USA, Tel: (1) 414.382.2000, Fax: (1) 414.382.4444

EUROPE/MIDDLE EAST/AFRICA: Rockwell Automation NV, Pegasus Park, De Kleetlaan 12a, 1831 Diegem, Belgium, Tel: (32) 2 663 0600, Fax: (32) 2 663 0640

ASIA PACIFIC: Rockwell Automation, Level 14, Core F, Cyberport 3, 100 Cyberport Road, Hong Kong, Tel: (852) 2887 4788, Fax: (852) 2508 1846

UNITED KINGDOM: Rockwell Automation Ltd, Pitfield, Kiln Farm Milton Keynes, MK11 3DR, United Kingdom, Tel: (44)(1908) 838-800, Fax: (44)(1908) 261-917

Allen-Bradley, ControlLogix, expanding human possibility, PHOTOSWITCH, and Rockwell Automation are trademarks of Rockwell Automation, Inc. Trademarks not belonging to Rockwell Automation are property of their respective companies.