

# Installation Instructions

Original Instructions



**Allen-Bradley**

by ROCKWELL AUTOMATION

## ArmorBlock I/O DeviceNet Module

Catalog Numbers 1732D-8CFG8

Topic	Page
Summary of Changes	1
Overview	1
Environment and Enclosure	3
Prevent Electrostatic Discharge	3
Electrical Safety Considerations	3
Install the Module	4
Set the Node Address	5
Mount the Module	5
Connect the I/O, Network, and Auxiliary Cable to the Module	6
Configure the Module	8
Interpret Status Indicators	8
Specifications	10

### Summary of Changes

This publication contains the following new or updated information. This list includes substantive updates only and is not intended to reflect all changes.

Topic	Page
Updated cordset catalog reference	8

### Overview

The ArmorBlock® I/O DeviceNet® module is a standalone 24V DC I/O module that communicates over the DeviceNet network. The sealed IP67 housing of these modules requires no enclosure. I/O connectors are sealed M8 (Pico™) style while the network and auxiliary power connectors are sealed M12 style.



**ATTENTION:** Read this document and the documents listed in the Additional Resources section about installation, configuration and operation of this equipment before you install, configure, operate or maintain this product. Users are required to familiarize themselves with installation and wiring instructions in addition to requirements of all applicable codes, laws, and standards.

Activities including installation, adjustments, putting into service, use, assembly, disassembly, and maintenance are required to be carried out by suitably trained personnel in accordance with applicable code of practice. If this equipment is used in a manner not specified by the manufacturer, the protection provided by the equipment may be impaired.

**注意:** 在安装、配置、操作和维护本产品前, 请阅读本文档以及“其他资源”部分列出的有关设备安装、配置和操作的相应文档。除了所有适用规范、法律和标准的相关要求之外, 用户还必须熟悉安装和接线说明。

安装、调整、投运、使用、组装、拆卸和维护等各项操作必须由经过适当训练的专业人员按照适用的操作规范实施。

如果未按照制造商指定的方式使用该设备, 则可能会损害设备提供的保护。

**ATENCIÓN:** Antes de instalar, configurar, poner en funcionamiento o realizar el mantenimiento de este producto, lea este documento y los documentos listados en la sección Recursos adicionales acerca de la instalación, configuración y operación de este equipo. Los usuarios deben familiarizarse con las instrucciones de instalación y cableado y con los requisitos de todos los códigos, leyes y estándares vigentes.

El personal debidamente capacitado debe realizar las actividades relacionadas a la instalación, ajustes, puesta en servicio, uso, ensamblaje, desensamblaje y mantenimiento de conformidad con el código de práctica aplicable. Si este equipo se usa de una manera no especificada por el fabricante, la protección provista por el equipo puede resultar afectada.

**ATENÇÃO:** Leia este e os demais documentos sobre instalação, configuração e operação do equipamento que estão na seção Recursos adicionais antes de instalar, configurar, operar ou manter este produto. Os usuários devem se familiarizar com as instruções de instalação e fiação além das especificações para todos os códigos, leis e normas aplicáveis.

É necessário que as atividades, incluindo instalação, ajustes, colocação em serviço, utilização, montagem, desmontagem e manutenção sejam realizadas por pessoal qualificado e especializado, de acordo com o código de prática aplicável.

Caso este equipamento seja utilizado de maneira não estabelecida pelo fabricante, a proteção fornecida pelo equipamento pode ficar prejudicada.

**ВНИМАНИЕ:** Перед тем как устанавливать, настраивать, эксплуатировать или обслуживать данное оборудование, прочитайте этот документ и документы, перечисленные в разделе «Дополнительные ресурсы». В этих документах изложены сведения об установке, настройке и эксплуатации данного оборудования. Пользователи обязаны ознакомиться с инструкциями по установке и прокладке соединений, а также с требованиями всех применимых норм, законов и стандартов.

Все действия, включая установку, наладку, ввод в эксплуатацию, использование, сборку, разборку и техническое обслуживание, должны выполняться обученным персоналом в соответствии с применимыми нормами и правилами.

Если оборудование используется не предусмотренным производителем образом, защита оборудования может быть нарушена.

**注意:** 本製品を設置、構成、稼働または保守する前に、本書および本機器の設置、設定、操作についての参考資料の該当箇所に記載されている文書に目を通してください。ユーザは、すべての該当する条例、法律、規格の要件に加えて、設置および配線の手順に習熟している必要があります。

設置調整、運転の開始、使用、組立て、解体、保守を含む諸作業は、該当する実施規則に従って訓練を受けた適切な作業員が実行する必要があります。本機器が製造メーカーにより指定されていない方法で使用される場合、機器により提供されている保護が損なわれる恐れがあります。

**ACHTUNG:** Lesen Sie dieses Dokument und die im Abschnitt „Weitere Informationen“ aufgeführten Dokumente, die Informationen zu Installation, Konfiguration und Bedienung dieses Produkts enthalten, bevor Sie dieses Produkt installieren, konfigurieren, bedienen oder warten. Anwender müssen sich neben den Bestimmungen aller anwendbaren Vorschriften, Gesetze und Normen zusätzlich mit den Installations- und Verdrahtungsanweisungen vertraut machen.

Arbeiten im Rahmen der Installation, Anpassung, Inbetriebnahme, Verwendung, Montage, Demontage oder Instandhaltung dürfen nur durch ausreichend geschulte Mitarbeiter und in Übereinstimmung mit den anwendbaren Ausführungsanweisungen vorgenommen werden.

Wenn das Gerät in einer Weise verwendet wird, die vom Hersteller nicht vorgesehen ist, kann die Schutzfunktion beeinträchtigt sein.

**ATTENTION:** Lisez ce document et les documents listés dans la section Ressources complémentaires relatifs à l'installation, la configuration et le fonctionnement de cet équipement avant d'installer, configurer, utiliser ou entretenir ce produit. Les utilisateurs doivent se familiariser avec les instructions d'installation et de câblage en plus des exigences relatives aux codes, lois et normes en vigueur.

Les activités relatives à l'installation, le réglage, la mise en service, l'utilisation, l'assemblage, le démontage et l'entretien doivent être réalisées par des personnes formées selon le code de pratique en vigueur.

Si cet équipement est utilisé d'une façon qui n'a pas été définie par le fabricant, la protection fournie par l'équipement peut être compromise.

**주의:** 본 제품 설치, 설정, 작동 또는 유지 보수하기 전에 본 문서를 포함하여 설치, 설정 및 작동에 관한 참고 자료 섹션의 문서들을 반드시 읽고 숙지하십시오. 사용자는 모든 관련 규정, 법규 및 표준에서 요구하는 사항에 대해 반드시 설치 및 배선 지침을 숙지해야 합니다.

설치, 조정, 가동, 사용, 조립, 분해, 유지보수 등 모든 작업은 관련 규정에 따라 적절한 교육을 받은 사용자를 통해서만 수행해야 합니다.

본 장비를 제조사가 명시하지 않은 방법으로 사용하면 장비의 보호 기능이 손상될 수 있습니다.

**ATTENZIONE** Prima di installare, configurare ed utilizzare il prodotto, o effettuare interventi di manutenzione su di esso, leggere il presente documento ed i documenti elencati nella sezione "Altre risorse", riguardanti l'installazione, la configurazione ed il funzionamento dell'apparecchiatura. Gli utenti devono leggere e comprendere le istruzioni di installazione e cablaggio, oltre ai requisiti previsti dalle leggi, codici e standard applicabili.

Le attività come installazione, regolazioni, utilizzo, assemblaggio, disassemblaggio e manutenzione devono essere svolte da personale adeguatamente addestrato, nel rispetto delle procedure previste.

Qualora l'apparecchio venga utilizzato con modalità diverse da quanto previsto dal produttore, la sua funzione di protezione potrebbe venire compromessa.

**DİKKAT:** Bu ürünün kurulumu, yapılandırılması, işletilmesi veya bakımı öncesinde bu dokümanı ve bu ekipmanın kurulumu, yapılandırılması ve işletimi ile ilgili ilave Kaynaklar bölümünde yer listelenmiş dokümanları okuyun. Kullanıcılar yürürlükteki tüm yönetmelikler, yasalar ve standartların gereksinimlerine ek olarak kurulum ve kablolama talimatlarını da öğrenmek zorundadır. Kurulum, ayarlama, hizmete alma, kullanma, parçaları birleştirme, parçaları sökme ve bakım gibi aktiviteler sadece uygun eğitimleri almış kişiler tarafından yürürlükteki uygulama yönetmeliklerine uygun şekilde yapılabilir.

Bu ekipman üretici tarafından belirlenmiş amacın dışında kullanılırsa, ekipman tarafından sağlanan koruma bozulabilir.

**注意事項:** 在安装、設定、操作或維護本產品前, 請先閱讀此文件以及列於「其他資源」章節中有關安裝、設定與操作此設備的文件。使用者必須熟悉安裝和配線指示, 並符合所有法規、法律和標準要求。

包括安裝、調整、交付使用、使用、組裝、拆卸和維護等動作都必須交由已經適當訓練的人員進行, 以符合適用的實作法規。

如果將設備用於非製造商指定的用途時, 可能會造成設備所提供的保護功能受損。

**POZOR:** Než začnete instalovat, konfigurovat či provozovat tento výrobek nebo provádět jeho údržbu, přečtěte si tento dokument a dokumenty uvedené v části Dodatečné zdroje ohledně instalace, konfigurace a provozu tohoto zařízení. Uživatelé se musejí vedle požadavků všech relevantních vyhlášek, zákonů a norem nutně seznámit také s pokyny pro instalaci a elektrické zapojení.

Činnosti zahrnující instalaci, nastavení, uvedení do provozu, užívání, montáž, demontáž a údržbu musí vykonávat vhodné proškolený personál v souladu s příslušnými prováděcími předpisy. Pokud se toto zařízení používá způsobem neodpovídajícím specifikaci výrobce, může být narušena ochrana, kterou toto zařízení poskytuje.

**UWAGA:** Przed instalacją, konfiguracją, użytkowaniem lub konserwacją tego produktu należy przeczytać niniejszy dokument oraz wszystkie dokumenty wymienione w sekcji Dodatkowe źródła omawiające instalację, konfigurację i procedury użytkowania tego urządzenia. Użytkownicy mają obowiązek zapoznać się z instrukcjami dotyczącymi instalacji oraz oprzewodowania, jak również z obowiązującymi kodeksami, prawem i normami.

Działania obejmujące instalację, regulację, przekazanie do użytkowania, użytkowanie, montaż, demontaż oraz konserwację muszą być wykonywane przez odpowiednio przeszkolony personel zgodnie z obowiązującym kodeksem postępowania.

Jeśli urządzenie jest użytkowane w sposób inny niż określony przez producenta, zabezpieczenie zapewniane przez urządzenie może zostać ograniczone.

**Obs:** Läs detta dokument samt dokumentet, som står listat i avsnittet Övriga resurser, om installation, konfigurering och drift av denna utrustning innan du installerar, konfigurerar eller börjar använda eller utföra underhållsarbete på produkten. Användare måste bekanta sig med instruktioner för installation och kabeldragning, förutom krav enligt gällande koder, lagar och standarder.

Åtgärder som installation, justering, service, användning, montering, demontering och underhållsarbete måste utföras av personal med lämplig utbildning enligt lämpligt bruk.

Om denna utrustning används på ett sätt som inte anges av tillverkaren kan det hända att utrustningens skyddsanordningar försätts ur funktion.

**LET OP:** Lees dit document en de documenten die genoemd worden in de paragraaf Aanvullende informatie over de installatie, configuratie en bediening van deze apparatuur voordat u dit product installeert, configureert, bedient of onderhoudt. Gebruikers moeten zich vertrouwd maken met de installatie en de bedradinginstructies, naast de vereisten van alle toepasselijke regels, wetten en normen.

Activiteiten zoals het installeren, afstellen, in gebruik stellen, gebruiken, monteren, demonteren en het uitvoeren van onderhoud mogen uitsluitend worden uitgevoerd door hiervoor opgeleid personeel en in overeenstemming met de geldende praktijkregels.

Indien de apparatuur wordt gebruikt op een wijze die niet is gespecificeerd door de fabrikant, dan bestaat het gevaar dat de beveiliging van de apparatuur niet goed werkt.

---

## Environment and Enclosure

---



**ATTENTION:** This equipment is intended for use in overvoltage Category II applications (as defined in EN/IEC 60664-1), at altitudes up to 2000 m (6562 ft) without derating.

This equipment is not intended for use in residential environments and may not provide adequate protection to radio communication services in such environments.

This equipment is supplied as Type 1 enclosed equipment (Only when provided with dust cap on the Input and Output connectors or terminated with cables). It should not require additional system enclosure when used in locations consistent with the equipment Enclosure Type Ratings. Subsequent sections of this publication may contain more information regarding specific enclosure type ratings, beyond what this product provides, that are required to comply with certain product safety certifications

In addition to this publication, see the following:

- Industrial Automation Wiring and Grounding Guidelines, publication [1770-4.1](#), for more installation requirements.
  - NEMA Standard 250 and EN/IEC 60529, as applicable, for explanations of the degrees of protection provided by enclosures.
- 



**ATTENTION:**

- Make sure that all connectors and caps are securely tightened to properly seal the connections against leaks and maintain Type 1 and IP enclosure type requirements.
  - These devices are intended for installation on Industrial Machines in accordance with NFPA79. Due to the nature of these devices (fixed equipment using cable connections) they may not be considered suitable for fixed installation in accordance with the NEC (NFPA70).
  - Read this document and the documents listed in the Additional Resources section about installation, configuration, and operation of this equipment before you install, configure, operate, or maintain this product. Users are required to familiarize themselves with installation and wiring instructions in addition to requirements of all applicable codes, laws, and standards.
  - Installation, adjustments, putting into service, use, assembly, disassembly, and maintenance are required to be carried out by suitably trained personnel in accordance with applicable code of practice.
  - In case of malfunction or damage, no attempts at repair should be made. The module should be returned to the manufacturer for repair. Do not dismantle the module.
- 

## Prevent Electrostatic Discharge

---



**ATTENTION:** This equipment is sensitive to electrostatic discharge, which can cause internal damage and affect normal operation. Follow these guidelines when you handle this equipment:

- Touch a grounded object to discharge potential static.
  - Wear an approved grounding wriststrap.
  - Do not touch connectors or pins on component boards.
  - Do not touch circuit components inside the equipment.
  - Use a static-safe workstation, if available.
  - Store the equipment in appropriate static-safe packaging when not in use.
- 

## Electrical Safety Considerations

---



**ATTENTION:** Power to this equipment and all connected I/O must be supplied from a source compliant with the following:

- Limited Voltage Supply compliant with UL508
- 

### IMPORTANT

Any illustrations, charts, sample programs, and layout examples shown in this publication are intended solely for the purposes of example. Since there are many variables and requirements associated with any particular installation, Rockwell Automation does not assume responsibility or liability for actual use based on the examples shown in this publication.

---



At the end of its life, this equipment should be collected separately from any unsorted municipal waste.

---

Module Identification

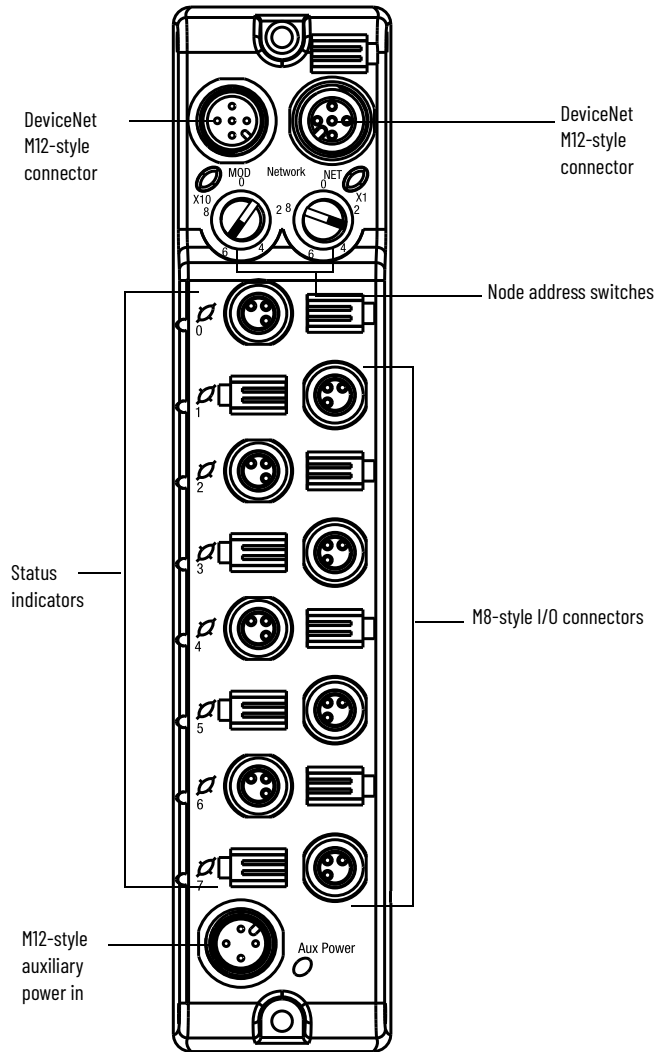

**ATTENTION:** Make sure that all connectors and caps are securely tightened to properly seal the connections against leaks and maintain Type 1 and IP enclosure type requirements.

Catalog Number Explanation

See the table for a description of the module catalog number.

Catalog Number	Description	Network Connector	I/O Connector	Auxiliary Power
1732D-8CFG8	8 channel 24V DC configurable digital DeviceNet module	Dual 5-pin M12	8, 3-pin M8	Single 4-pin M12

Install the Module

To install the module:

- Set the network address
- Mount the module
- Connect the I/O, Network, and Auxiliary cables to the module.

## Set the Node Address

Valid node addresses are 00...63.

Set the node address using either the rotary switches, RSNetWorx™ for DeviceNet, DeviceNetManager™, or another software configuration tool. Setting the switches at any number from 64 to 99 lets the software have address control.

Each module is shipped set for node address 63. Remove the caps on the front of the module to access the switches. The two switches are:

- X10 (most significant digit) – left side of module
- X1 (least significant digit) – right side of module

To reset the node address, use a small blade screwdriver to rotate the switches. Align the small black dot on the switch with the number setting you wish to use and then cycle power.

The rotary switches are read periodically. If the switches have been changed since the last time they were read and they no longer match the on line address, a minor fault will occur, which is indicated by a flashing red MOD light-emitting diode (LED). Settings between 64 and 99 cause the module to use the last valid node address stored internally. Example: The last setting internally was 40. If a change is made to 68, and then you power up, the address will default to 40.

## Set Network Address

Example shows default node address set at 63.

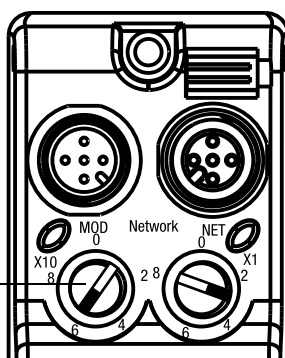

The module is equipped with Auto Baud detect. Auto Baud lets the module read the settings already in use on your DeviceNet network and automatically adjusts to follow those settings.

## Mount the Module

Each module has two sets of mounting holes that are used to mount the module directly to a panel or machine. The module can be front or side mounted. Mounting holes accommodate #6 (M3) pan head screws. The torque specification is 0.67 N•m (6 in•lb).

## Product Dimensions

See the mounting dimensions illustration to help you mount the module.

**Module Dimensions**

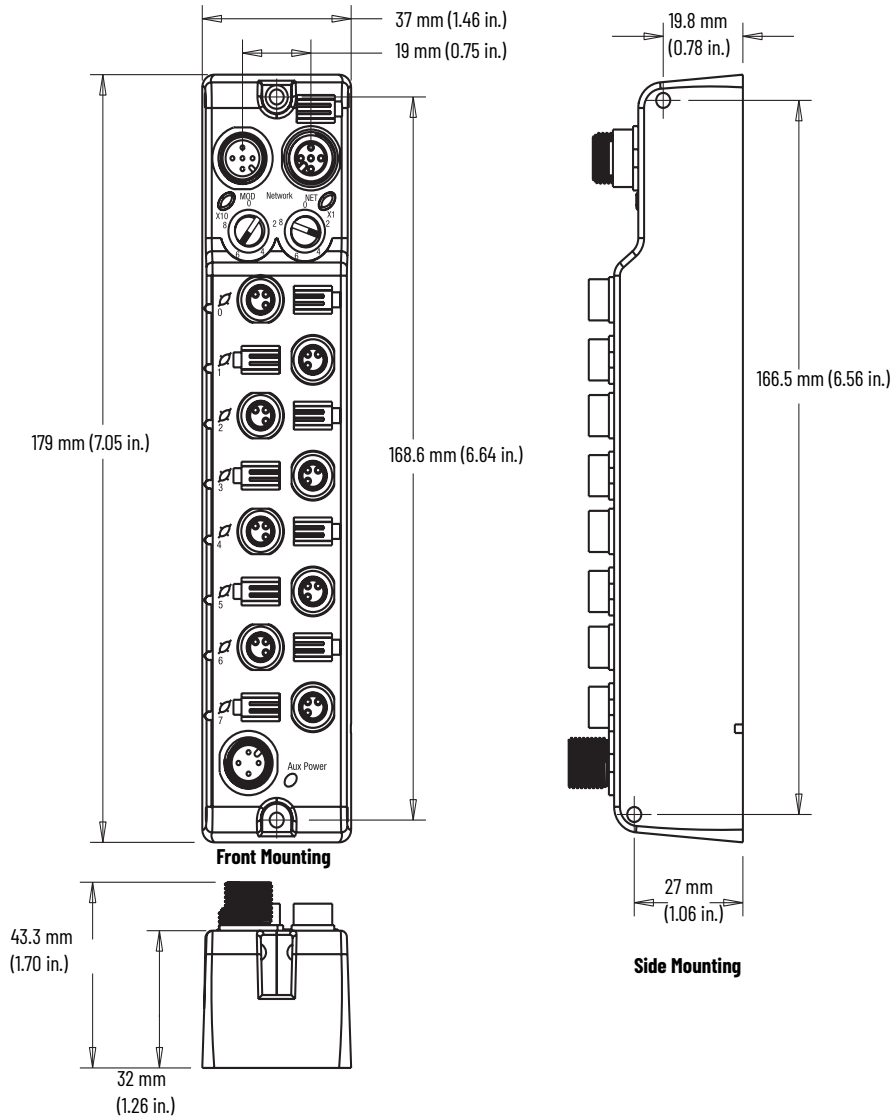

**Mount the Module in High Vibration Areas**

If you will mount the module in an area that is subject to shock or vibration, we recommend that you use a flat and lock washer to mount the module. Mount the flat and lock washer as shown in the following illustration. Torque the mounting screws to 0.67 N•m (6 in•lb).

**High Vibration Area Mounting**

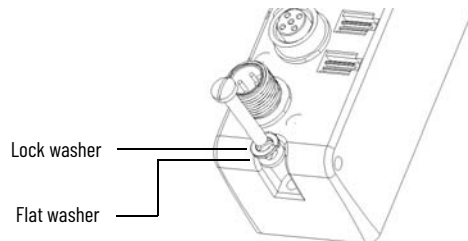

**Connect the I/O, Network, and Auxiliary Cable to the Module**

The ArmorBlock family offers 5-pin micro-style PCB mounting connectors or 3-pin pico-style PCB mounting connectors. We provide caps to cover the unused connectors on your module. Connect the quick-disconnect cord sets you selected for your module to the appropriate ports.

I/O Connectors

**Self-configuring Modules**

The 1732D-8CFGM8 self-configuring module contains both input and output functionality.

If an I/O point is to be an output, dedicate that point as an output with a wired load and energize it through a control program. Energized outputs will show an associated active input, which can be used as a feedback mechanism to ensure that the output is turned on.

If an I/O point is to be an input, wire the input device as normal and leave the associated output unenergized at all times.

**Pico-style 3-pin Female Connector**

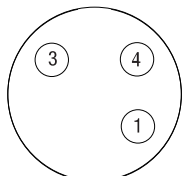

View into Connector

Pin	Function
1	Sensor source voltage
3	Return
4	Input or output



**ATTENTION:** Make sure that all connectors and caps are securely tightened to properly seal the connections against leaks and maintain Type 1 and IP enclosure and requirements.

**IMPORTANT**

If the devices (sensors) connected to the input connections require Class 2 power to operate, the auxiliary power connections of this equipment must be powered by a Class 2 source.

**I/O Self-configure Circuitry**

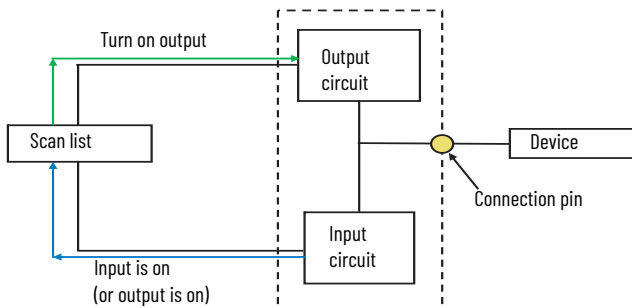

*DeviceNet Connector*

**Micro-style 5-pin Input Male Connector**

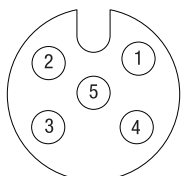

View into Connector 1

Pin	Value
1	Drain
2	V+
3	V-
4	CAN_H
5	CAN_L

**Micro-style 5-pin Output Female Connector**

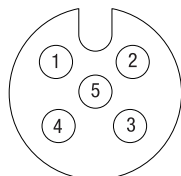

View into Connector 2

Pin	Value
1	Drain
2	V+
3	V-
4	CAN_H
5	CAN_L

To terminate the module, use the second DeviceNet connector and a Rockwell Automation® termination resistor (Cat. No. 1485A-T1D5).

### Auxiliary Power Connector

Input and output devices are powered through the module I/O connectors. Removing auxiliary power will deactivate all sensors and actuators unless they are powered from a separate source. If a separate source is used, devices may still be active, even if auxiliary power is removed. To ensure that auxiliary power controls the activation/deactivation of sensors and actuators, always wire input sensors and output actuators directly to the I/O connectors. Attach the mini-style 4-pin connector to the mini-style 4-pin receptacle as shown.

### Micro-style 4-Pin Male Connector

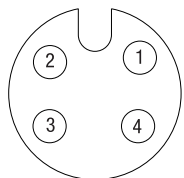

View into Connector

Pin	Value	Function
1	24V DC	Output power+
2	24V DC	Sensor/MDL power+
3	Return	Sensor/MDL power-
4	Return	Output power-



**ATTENTION:** This equipment is considered Group 1, Class A industrial equipment according to IEC/CISPR 11. Without appropriate precautions, there may be difficulties with electromagnetic compatibility in residential and other environments due to conducted and radiated disturbance.

## Configure the Module

See Essential Components Selection Guide, publication [EC-CA100](#), for Rockwell Automation cable and cord set offerings or use the configuration tools available at [rok.auto/systemtools](http://rok.auto/systemtools).

## Communicate With Your Module

This ArmorBlock module I/O is exchanged with the master through a poll, change of state, or cyclic connection.

**Cyclic** – allows configuration of the block as an I/O client. The block will produce and consume its I/O cyclically at the rate configured.

**Polled** – a master initiates communication by sending its polled I/O message to the module. The module consumes the message, updates outputs, and produces a response. The response has input data.

**Change of state** – productions occur when an input changes or a fault condition occurs. If no input or fault condition change occurs within the expected packet rate, a heartbeat production occurs. This heartbeat production tells the scanner module that the I/O module is alive and ready to communicate. Consumption occurs when data changes and the master produces new output data to the I/O block.

Byte	Bit 7	Bit 6	Bit 5	Bit 4	Bit 3	Bit 2	Bit 1	Bit 0
Produced 0	I7	I6	I5	I4	I3	I2	I1	I0
Consumes 0	O7	O6	O5	O4	O3	O2	O1	O0

Where: I = Input 0 = Output

The 1732D-8CFGM8 self-assigning module contains both input and output functionality. The module does not need to be configured.

If an I/O point is to be an output, dedicate that point as an output with a wired load and energize it through a control program.

If an I/O point is to be an input, wire the input device as normal and leave the associated output unenergized at all times.

## Interpret Status Indicators

This module has the following indicators:



- Network and Module status indicators for DeviceNet
- Auxiliary power indicator
- Individual I/O status indicators for inputs and outputs

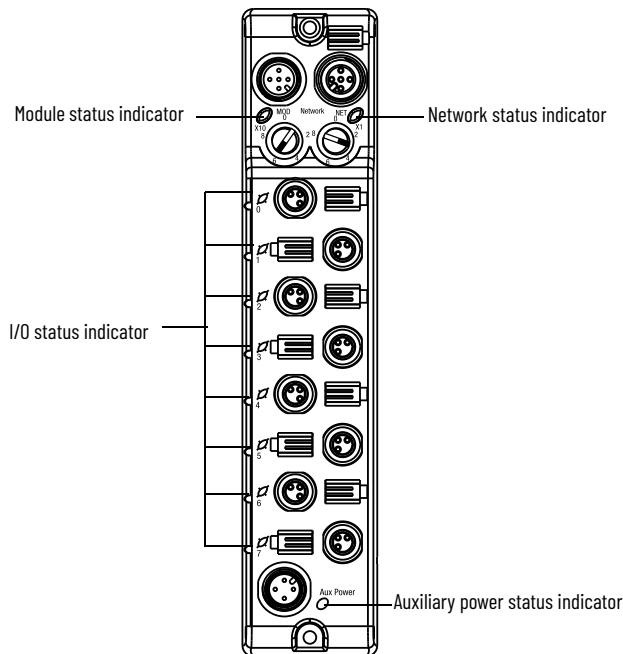

**Indicator Status for Modules**

	Status	Description
Module status	Off	No power applied to device.
	Flashing green	The module needs commissioning due to missing, incomplete, or incorrect configuration.
	Green	Device operating normally.
	Flashing red	Recoverable fault.
	Red	Watchdog timeout or the module has an unrecoverable fault and may need replacing.
Network status	Off	Device is not online: <ul style="list-style-type: none"> <li>• The device has not completed the dup_MAC_id test yet.</li> <li>• The device may not be powered yet.</li> </ul>
	Flashing green	The device is on line with no connections in the established state. <ul style="list-style-type: none"> <li>• The device has passed the dup_MAC_id test, is on line, but has no established connections to other nodes.</li> <li>• As a Group 2 device, it means that the device is not allocated to a master.</li> </ul>
	Green	The device is operating in a normal condition and the device is on line with connections in the established state. <ul style="list-style-type: none"> <li>• As a Group 2 device, it means that the device is allocated to a master.</li> </ul>
	Flashing red	An I/O connection has timed out.
	Red	Failed communication device - The device has detected an error that has rendered it incapable of communication on the network (dup_MAC_id failure or bus-off).
	Flashing red/green	The module is performing a powerup self-test.
Auxiliary power status	Off	No auxiliary power
	Green	Auxiliary power is present.
Digital output status	Off	Output not energized.
	Yellow	Output energized and output power applied.
Digital input status	Off	No valid input.
	Yellow	Valid input.

## Specifications

### Input Specifications - 1732D-8CFG8

Attribute	Value
Number of inputs	8
Voltage, off-state input, max	5V DC
Voltage, on-state input, max	30V DC
Voltage, on-state input, min	11V DC
Current, off-state input, max	1.5 mA
Current, on-state input, max	5 mA
Voltage, sensor source, max	30V DC
Voltage, sensor source, min	11V DC
Current, sensor source, max (per input)	50 mA
Current, sensor source, max (per module)	400 mA
Input delay time ON to OFF OFF to ON	0...16000 µs

### Output Specifications - 1732D-8CFG8

Attribute	Value
Number of outputs	8
Voltage drop, on-state output, max	0.5V DC
Voltage off-peak blocking, min	30V DC
Voltage, on-state output, max	30V DC
Current on-state output, max	0.5 A
Current per module, max	4.0 A
Leakage current, off-state output, max	50 µA
Surge current per output, min	1.2 A for 10 ms, repeatable every 2 s
Isolation voltage	Tested at 500V DC for 60 s, between auxiliary power and network (I/O to logic)

### General Specifications

Attribute	Value
Voltage, auxiliary power, max	30V DC
Voltage, auxiliary power, min	11V DC
Voltage, DeviceNet power, max	25V DC
Voltage, DeviceNet power, min	11V DC
Current, DeviceNet power, max	100 mA
Current, DeviceNet power, min	100 mA
Current, I/O channel, max	4 A
Current, auxiliary power connector, max per module	10 A
Current, sensor source, per input, max	50 mA
Current, sensor source, per connector, max	100 mA
Communication rate	125 Kbps @ 500 m (1640 ft) for thick cable, flat media length 375 m (1378 ft) 250 Kbps @ 200 m (600 ft) for thick cable, flat media length 150 m (492 ft) 500 Kbps @ 100 m (330 ft) for thick cable, flat media length 75 m (246 ft)
Status indicators	Module status - red/green Network status - red/green Auxiliary power - green I/O LED - yellow

## General Specifications (Continued)

Attribute	Value
Dimensions (HxWxD), approx.	174 x 69 x 48 mm (6.9 x 2.7 x 1.9 in.)
Weight, approx.	203 g (7.16 oz.)
Enclosure type rating	Meets IP65/67/69K (when marked)
Wiring category <sup>(1)(2)</sup>	2 - on signal ports
Isolation voltage	Basic Tested at 500V DC for 60 s, between auxiliary power and network (I/O to logic)

(1) Use this Conductor Category information for planning conductor routing. See Industrial Automation Wiring and Grounding Guidelines, publication [1770-4.1](#).

(2) Use this Conductor Category information for planning conductor routing as described in the appropriate System Level Installation Manual.

## Environmental Specifications

Attribute	Value
Temperature, operating	IEC 60068-2-1 (Test Ad, Operating Cold), IEC 60068-2-2 (Test Bd, Operating Dry Heat), IEC 60068-2-14 (Test Nb, Operating Thermal Shock): -20 °C < Ta < +60 °C (-4 °F < Ta < +140 °F)
Temperature, ambient, max.	60 °C (140 °F)
Temperature, nonoperating	IEC 60068-2-1 (Test Ab, Unpackaged nonoperating Cold), IEC 60068-2-2 (Test Bb, Unpackaged nonoperating Dry Heat), IEC 60068-2-14 (Test Na, Unpackaged nonoperating Thermal Shock): -40...+85 °C (-40...+185 °F)
Relative humidity	IEC 60068-2-30 (Test Db, Unpackaged Damp Heat): 5...95% noncondensing
Vibration	IEC 60068-2-6 (Test Fc, Operating): 5 g @ 10...500 Hz
Shock, operating	IEC 60068-2-27 (Test Ea, Unpackaged Shock): 30 g
Shock, nonoperating	IEC 60068-2-27 (Test Ea, Unpackaged Shock): 50 g
Emissions	IEC 61000-6-4
ESD immunity	IEC 61000-4-2: 6 kV contact discharges 8 kV air discharges
Radiated RF immunity	IEC 61000-4-3: 10V/m with 1 kHz sine-wave 80% AM from 80...2000 MHz 10V/m with 200 Hz 50% Pulse 100% AM @ 900 MHz 10V/m with 200 Hz 50% Pulse 100% AM @ 1890 MHz 10V/m with 1 kHz sine-wave 80% AM from 2000...2700 MHz
EFT/B immunity	IEC 61000-4-4: ±4 kV @ 5 kHz on power ports ±2 kV @ 5 kHz on signal ports ±2 kV @ 5 kHz on communications ports
Surge transient immunity	IEC 61000-4-5: ±1 kV line-line(DM) and ±2 kV line-earth(CM) on power ports ±1 kV line-line(DM) and ±2 kV line-earth(CM) on signal ports ±2 kV line-earth(CM) on shielded ports
Conducted RF immunity	IEC 61000-4-6: 10V rms with 1 kHz sine-wave 80% AM from 150 kHz...80 MHz

## Certifications

Certification (when product is marked) <sup>(1)</sup>	Value
c-UL-us	UL Listed Industrial Control Equipment, certified for US and Canada. See UL File E322657.
CE	European Union 2014/30/EU EMC Directive, compliant with: EN 61326-1; Meas./Control/Lab., Industrial Requirements EN 61000-6-2; Industrial Immunity EN 61000-6-4; Industrial Emissions EN 61131-2; Programmable Controllers (Clause 8, Zone A & B) European Union 2011/65/EU RoHS, compliant with: EN 50581; Technical documentation
RCM	Australian Radiocommunications Act, compliant with: EN 61000-6-4; Industrial Emissions
KC	Korean Registration of Broadcasting and Communications Equipment, compliant with: Article 58-2 of Radio Waves Act, Clause 3
DeviceNet	ODVA conformance tested to DeviceNet specifications.

(1) See the Product Certification link at [rok.auto/certifications](http://rok.auto/certifications) for Declaration of Conformity, Certificates, and other certification details.

## Additional Resources

These documents contain additional information concerning related products from Rockwell Automation.

Resource	Description
Industrial Automation Wiring and Grounding Guidelines, publication <a href="#">1770-4.1</a>	Provides general guidelines for installing a Rockwell Automation industrial system.
Product Certifications website: <a href="http://rok.auto/certifications">rok.auto/certifications</a>	Provides declarations of conformity, certificates, and other certification details.

If you would like a manual, you can:

- download a free electronic version from the Internet: [rok.auto/literature](http://rok.auto/literature).
- purchase a printed manual by contacting your local Allen-Bradley® distributor or Rockwell Automation representative

**Notes:**





# Rockwell Automation Support

Use these resources to access support information.

<b>Technical Support Center</b>	Find help with how-to videos, FAQs, chat, user forums, and product notification updates.	<a href="http://rok.auto/support">rok.auto/support</a>
<b>Knowledgebase</b>	Access Knowledgebase articles.	<a href="http://rok.auto/knowledgebase">rok.auto/knowledgebase</a>
<b>Local Technical Support Phone Numbers</b>	Locate the telephone number for your country.	<a href="http://rok.auto/phonesupport">rok.auto/phonesupport</a>
<b>Literature Library</b>	Find installation instructions, manuals, brochures, and technical data publications.	<a href="http://rok.auto/literature">rok.auto/literature</a>
<b>Product Compatibility and Download Center (PCDC)</b>	Download firmware, associated files (such as AOP, EDS, and DTM), and access product release notes.	<a href="http://rok.auto/pcdc">rok.auto/pcdc</a>

## Documentation Feedback

Your comments help us serve your documentation needs better. If you have any suggestions on how to improve our content, complete the form at [rok.auto/docfeedback](http://rok.auto/docfeedback).

## Waste Electrical and Electronic Equipment (WEEE)







At the end of life, this equipment should be collected separately from any unsorted municipal waste.

Rockwell Automation maintains current product environmental compliance information on its website at [rok.auto/pec](http://rok.auto/pec).

Your comments help us serve your documentation needs better. If you have any suggestions on how to improve our content, complete the form at [rok.auto/docfeedback](http://rok.auto/docfeedback).

For technical support, visit [rok.auto/support](http://rok.auto/support).

Rockwell Otomasyon Ticaret A.Ş. Kar Plaza İş Merkezi E Blok Kat:6 34752 Çeremköy, İstanbul, Tel: +90 (216) 5698400 EEE Yönetmeliğine Uygundur

Connect with us.    

**rockwellautomation.com** — expanding **human possibility**<sup>™</sup>

AMERICAS: Rockwell Automation, 1201 South Second Street, Milwaukee, WI 53204-2496 USA, Tel: (1) 414.382.2000, Fax: (1) 414.382.4444

EUROPE/MIDDLE EAST/AFRICA: Rockwell Automation NV, Pegasus Park, De Kleetlaan 12a, 1831 Diegem, Belgium, Tel: (32) 2 663 0600, Fax: (32) 2 663 0640

ASIA PACIFIC: Rockwell Automation, Level 14, Core F, Cyberport 3, 100 Cyberport Road, Hong Kong, Tel: (852) 2887 4788, Fax: (852) 2508 1846

Allen-Bradley, ArmorBlock, DeviceNetManager, expanding human possibility, FactoryTalk, Pico, Rockwell Automation, RSNetWorx, and TechConnect are trademarks of Rockwell Automation, Inc.

DeviceNet is a trademark of ODVA, Inc.

Trademarks not belonging to Rockwell Automation are property of their respective companies.

Publication 1732D-IN003B-EN-P - July 2020 | Supersedes Publication 1732D-IN003A-EN-P-April 2020

Copyright © 2020 Rockwell Automation, Inc. All rights reserved. Printed in Singapore.

PN-593698