



Immersion Temperature Transmitter

Catalog Number(s) 1414-CTI03PBIAA,
1414-CTI03PDIAA, 1414-CTI03PEIAA, 1414-CTI03PFIAA,
1414-ITI03ABIAA, 1414-ITI03ADIAA, 1414-ITI03AEIAA,
1414-ITI03AFIAA, 1414-ITI02ABIAA, 1414-ITI02ADIAA,
1414-ITI02AEIAA, 1414-ITI02AFIAA



About the Immersion Temperature Transmitter

Immersion type probes are designed to measure the temperature inside pipes carrying liquid or steam. They are to be used with a thermowell. Brass (for non-corrosive liquids) and 304 stainless steel (for corrosive liquids) wells are available. The immersion temperature transmitter provides 4 to 20 mA current signal proportional to the sensed temperature and is loop powered. It is available to fit industrial and commercial applications.

Important User Information

Solid state equipment has operational characteristics differing from those of electromechanical equipment. *Safety Guidelines for the Application, Installation and Maintenance of Solid State Controls* (Publication SGI-1.1 available from your local Rockwell Automation sales office or online at <http://www.literature.rockwellautomation.com>) describes some important differences between solid state equipment and hard-wired electromechanical devices. Because of this difference, and also because of the wide variety of uses for solid state equipment, all persons responsible for applying this equipment must satisfy themselves that each intended application of this equipment is acceptable.





In no event will Rockwell Automation, Inc. be responsible or liable for indirect or consequential damages resulting from the use or application of this equipment.

The examples and diagrams in this manual are included solely for illustrative purposes. Because of the many variables and requirements associated with any particular installation, Rockwell Automation, Inc. cannot assume responsibility or liability for actual use based on the examples and diagrams.

No patent liability is assumed by Rockwell Automation, Inc. with respect to use of information, circuits, equipment, or software described in this manual.

Reproduction of the contents of this manual, in whole or in part, without written permission of Rockwell Automation, Inc., is prohibited.

Throughout this manual, when necessary, we use notes to make you aware of safety considerations.

<p>WARNING</p> 	<p>Identifies information about practices or circumstances that can cause an explosion in a hazardous environment, which may lead to personal injury or death, property damage, or economic loss.</p>
<p>IMPORTANT</p>	<p>Identifies information that is critical for successful application and understanding of the product.</p>
<p>ATTENTION</p> 	<p>Identifies information about practices or circumstances that can lead to personal injury or death, property damage, or economic loss. Attentions help you identify a hazard, avoid a hazard and recognize the consequences.</p>
<p>SHOCK HAZARD</p> 	<p>Labels may be located on or inside the equipment (e.g., drive or motor) to alert people that dangerous voltage may be present.</p>
<p>BURN HAZARD</p> 	<p>Labels may be located on or inside the equipment (e.g., drive or motor) to alert people that surfaces may be dangerous temperatures.</p>

Install the Immersion Temperature Transmitter

Immersion probes must be installed into a thermowell. Mount the thermowell either horizontally or with the open end facing down to allow any condensation to drain and ensure that the well does not contact the inside of the pipe. For best results, use thermal compound⁽¹⁾ inside the well and a spring loaded probe.

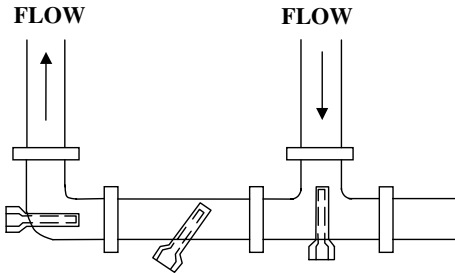

Thermowell Installation Example

Wire and Connect the Immersion Temperature Sensor

Connect the transmitter to the controller using twisted 18 to 22 AWG wire. The transmitter requires two wires for DC 4 to 20 mA loop-powered operation. The use of shielded cable is optional but recommended for the highest noise immunity. Do not route signal wires in the same conduit with power cables as signal degradation may occur. The controller Analog Input (AI) must be selected to match the transmitter output before power is applied. The AI type must be a current input with 250 or 500 ohm impedance. All transmitters have an operating range of 0 to 70°C (32 to 158°F). The transmitter board should not be mounted where temperatures exceed these values. See the connection diagram for more details.

Typical wiring to a programmable controller is shown in the diagram.

(1) Use thermal compound from MAMAC Systems, part number A-505.

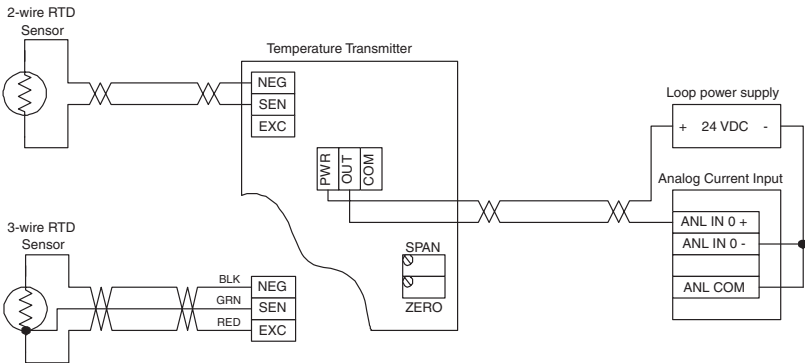

All two wire sensors are polarity insensitive. Three-wire RTD sensors are used in high temperature range applications (maximum temperature > 212°F). If desired, a three-wire sensor may be connected as two-wire by connecting together the EXCitation and SENse lines. If used, wire splices should be made using either buttspllices or soldering. The use of wire nuts is not recommended.

For 4 to 20 mA loop signal, only the PWR and OUT terminals are used.

High temperature probes have three wires; two wires of one color (usually black) and the third wire a different color (usually white).

Field Calibration

The unit can be calibrated in the field by using precision resistor values equal to the zero and span of the transmitter temperature range.

1. Disconnect the sensor from the transmitter and connect the resistor that represents the zero value to the EXC and NEG terminals.

TIP

If the unit uses a three-wire sensor, a jumper must be placed between EXC and SEN.

2. Adjust the ZERO pot until the desired output is achieved.
3. Connect the resistor that represents the span value to the EXC and NEG terminals.
4. Adjust the SPAN pot until the desired output is achieved.

Repeat these steps until no further adjustment is required.

Specifications

Immersion Temperature Transmitter Specifications

Specification	Value
Standard Length	4"
Operating Temperature Range	-40 ... 105 °C (-40 ... 221 °F)
Ambient Temperature Range	0 ... 70°C (32 ... 158°F)
Wiring Connections	Terminal Blocks
Enclosures	ABS, Metal or Weatherproof
Sensor Types	1000 Ω platinum Class A 0.15°C , Class B 0.3°C

All other trademarks are the property of their respective holders, and are hereby acknowledged.

www.rockwellautomation.com

Power, Control and Information Solutions Headquarters

Americas: Rockwell Automation, 1201 South Second Street, Milwaukee, WI 53204-2496 USA, Tel: (1) 414.382.2000, Fax: (1) 414.382.4444

Europe/Middle East/Africa: Rockwell Automation, Vorstlaan/Boulevard du Souverain 36, 1170 Brussels, Belgium, Tel: (32) 2 663 0600, Fax: (32) 2 663 0640

Asia Pacific: Rockwell Automation, Level 14, Core F, Cyberport 3, 100 Cyberport Road, Hong Kong, Tel: (852) 2887 4788, Fax: (852) 2508 1846

Publication 1414-IN008A-EN-P - October 2005

PN 40055-238-01(1)

Copyright © 2005 Rockwell Automation, Inc. All rights reserved. Printed in the U.S.A.