

When to use a Soft Starter or an AC Variable Frequency Drive

Product lines: Smart Motor Controllers (SMCs), AC Variable Frequency Drives (VFDs)

Topic	Page
Introduction	2
Starting Methods	3
How does a VFD work?	7
Comparisons	8
Wye-delta (Starting Inside the Delta) Motors	11
Communication Capabilities for Monitoring and Control	11
Harmonics, Wiring Methods and Installation Considerations	12
Starting and stopping time accuracy	12
Speed control	13
Full torque at 0 speed	14
Initial Cost	15
Physical Size	15
Maintenance	16
Starting and Stopping Options	17
Applications and Motors	19
Summary	20

Additional Resources

These documents contain additional information concerning related products from Rockwell Automation.

Resource	Description
Industrial Automation Wiring and Grounding Guidelines, publication 1770-4.1	Provides general guidelines for installing a Rockwell Automation industrial system.
Product Certifications website, http://www.ab.com	Provides declarations of conformity, certificates, and other certification details.

You can view or download publications at <http://www.rockwellautomation.com/literature/>. To order paper copies of technical documentation, contact your local Allen-Bradley distributor or Rockwell Automation sales representative.

LISTEN.
THINK.
SOLVE.®

Introduction

A common question when deciding between a soft starter or a drive is, which one to select?

The purpose of this publication is to show similarities and differences between the soft starter and the drive. When comparing the two devices, you should be able to pick the best device for the application. Many comparisons are done using Allen-Bradley Smart Motor Controllers (SMCs) and AC variable frequency drives (VFDs).

While the question is simple, the answer is not. If you examine the function and purpose of the soft starter and drive, the answer becomes clearer. Generally, the application determines the best fit. Common questions to ask are:

- Does the application need full torque at zero speed?
- Does the application need speed control once the motor is at speed?
- Does the application need constant torque?
- Does the application need precise starting and stopping times?
- Is space a consideration?

This publication helps explain some of the differences, and when to choose one type of controller over another.

Terminology

In this paper, the terms “Drives” and “VFD” are used interchangeably. Star-Delta and Wye-Delta are used interchangeably. Silicon-controlled rectifier (“SCR”) and “thyristor” are used interchangeably.

So when do you use a soft starter instead of a drive?

Here are some common applications of each:

Soft Starters

- Applications with low or medium starting torque
- Lightly loaded applications
- Little or no speed control during run mode
- Reduce mechanical wear and damage to system
- Controlling inrush
- Power monitoring

Drive

- Single-phase applications on certain drives
- Speed control and system efficiencies operating at reduced speeds during the run mode
- Applications with high starting torque
- Continuous feedback for critical position control
- Holding rotor at zero speed
- Reduce mechanical wear and damage to system

Starting Methods

Figure 1 - Starting Method Comparison

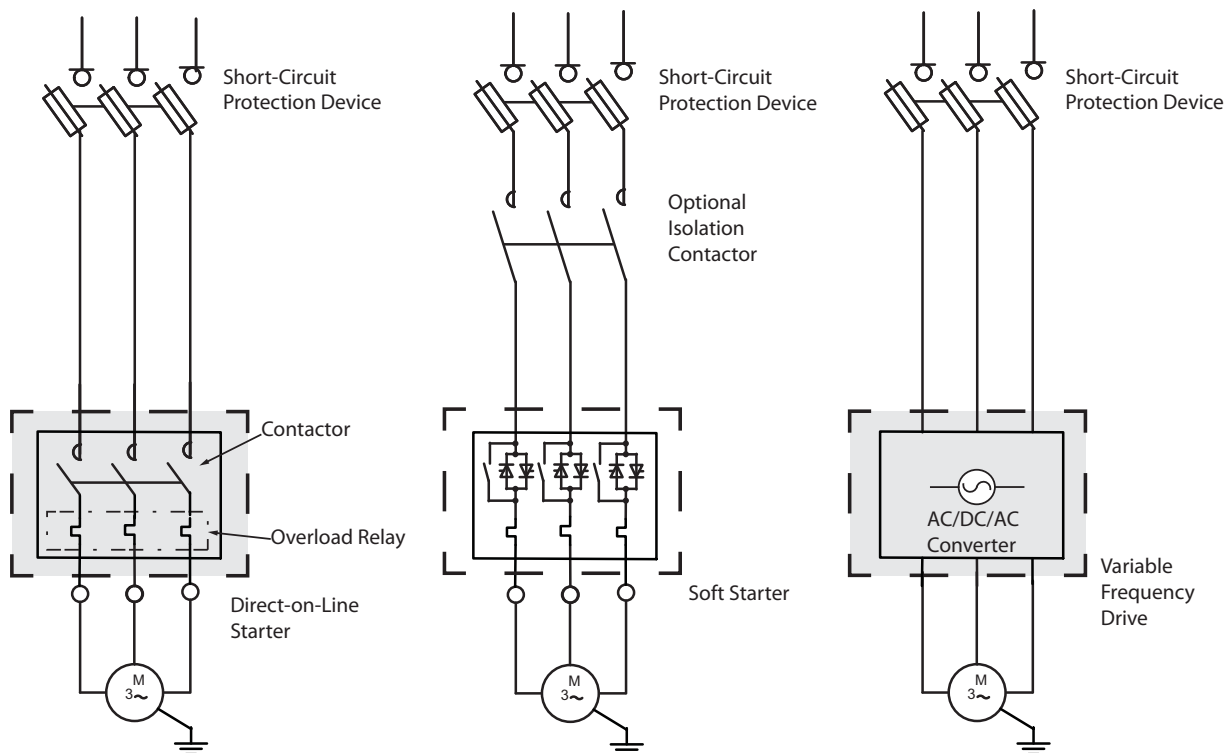

How does a Direct On Line (DOL) starter work?

As a basic starting method, a DOL (or 'Across-The-Line') starter applies full voltage, current, and torque immediately to the motor once a start command is provided. Normally, power is immediately removed once the stop signal is given. On and Off are the only two states of this method. Optional smart overloads can add complexity to the starter and feedback from the starter. [Figure 2](#) shows the typical NEMA Design B or IEC Class N motor torque and speed characteristics.

Figure 2 - Full-voltage Starting Torque/Speed Curve

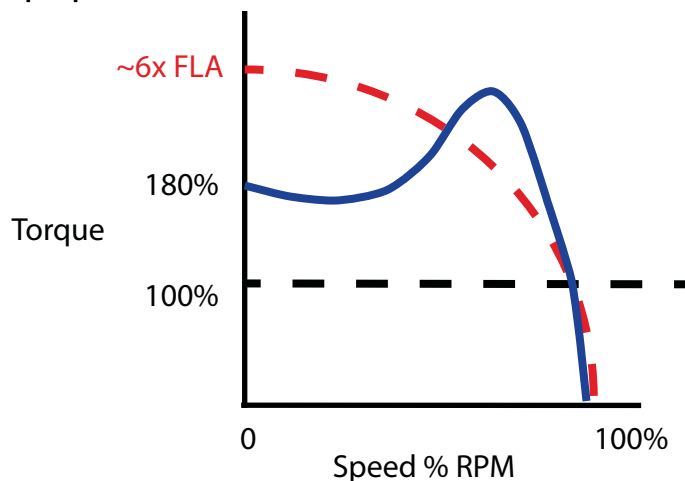

How does a soft starter work?

An algorithm controlling three pairs of back to back SCRs are used to start and stop the motor. The back to back orientation of the SCRs allows the AC voltage to be controlled by changing the firing angle every half cycle (Figure 4). Voltage is either ramped up to full voltage, or is limited to provide current limit starts.

Figure 3 - Basic Motor with SCR

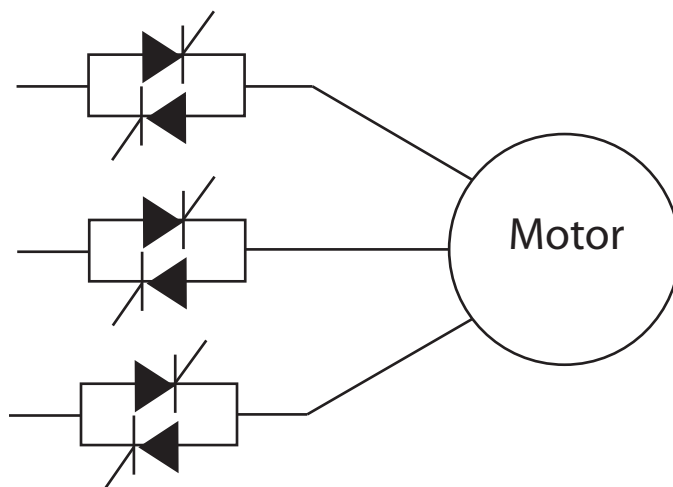
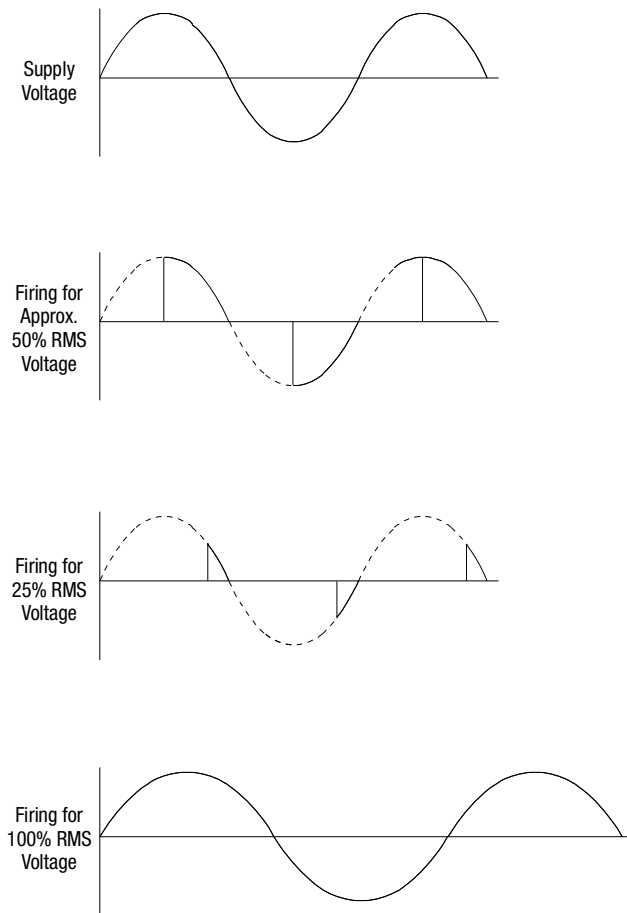

Figure 4 - Different Firing Angles (Single-Phase Simplification)

A soft starter uses voltage to control the current and torque. The motor torque is approximately proportional to the square of the applied voltage.

$$\% \text{ Torque} \propto \% \text{ Voltage}^2$$

Given this relationship, a 60% reduction in the applied voltage results in approximately an 84% reduction in generated torque. In this example, 40% voltage is used.

$$(0.4)^2 = 0.16, \text{ or } 16\% \text{ of Locked Rotor Torque is present.}$$

The current during the start is directly related to the voltage applied to the motor.

$$\frac{\text{Voltage (Applied)}}{\text{Voltage (Maximum)}} = \frac{\text{Current (Drawn)}}{\text{Current (Maximum)}}$$

[Table 1](#) shows starting methods of a full voltage, wye-delta (or star-delta), and a soft starter. Notice the reduction in starting torque in comparison to the starting voltage. A standard Wye-Delta start with contactors is achieved with current limit set to 350%, or starting torque set to 34% on the soft starter.

Table 1 - Type of Start, Voltage, Torque, and Current

Type of Start	% Voltage Applied During Start	% Full Load Starting Torque	% Full Load Rated Current
Full Voltage	100	100	600
Wye-Delta Starting	58	33	200
Soft Start with various current limit settings			
150%	25	6	150
200%	33	11	200
250%	42	18	250
300%	50	25	300
350%	58	34	350
400%	67	49	400
450%	75	56	450

Figure 5 - Back-to-Back SCR Configuration

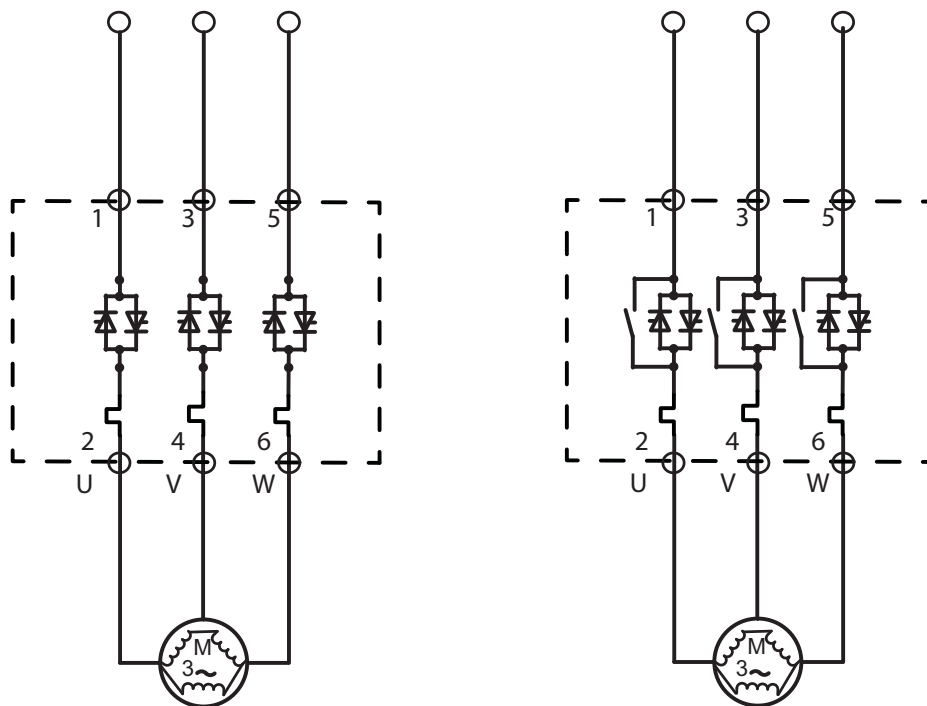

[Figure 5](#) shows back-to-back SCR configuration of the soft starter in line connected mode. Allen-Bradley SMC™-3 and SMC™ Flex soft starters have an integrated bypass contactor, which saves space and reduces the need to oversize the controller for the application. The Allen-Bradley SMC™-50 is fully solid state for harsh, dusty environments and applications with vibration.

For the bypass configuration, once the motor is brought up to speed, the bypass contactor is pulled in. Whether it's the internal bypass of the SMC-3 and SMC Flex, or an external bypass that is used with the SMC Flex or SMC-50, the SCRs stop firing, which makes the soft starter more efficient. Once a stop command is provided, the SCRs again take control for the stop. The contactor never makes or breaks a load, which allows you to use smaller contactors and SCRs, resulting in an overall smaller footprint. [Figure 6](#) shows a soft starter with customer-supplied external bypass contactor and overloads. Internal bypass uses the thermal overload protection of the soft starter.

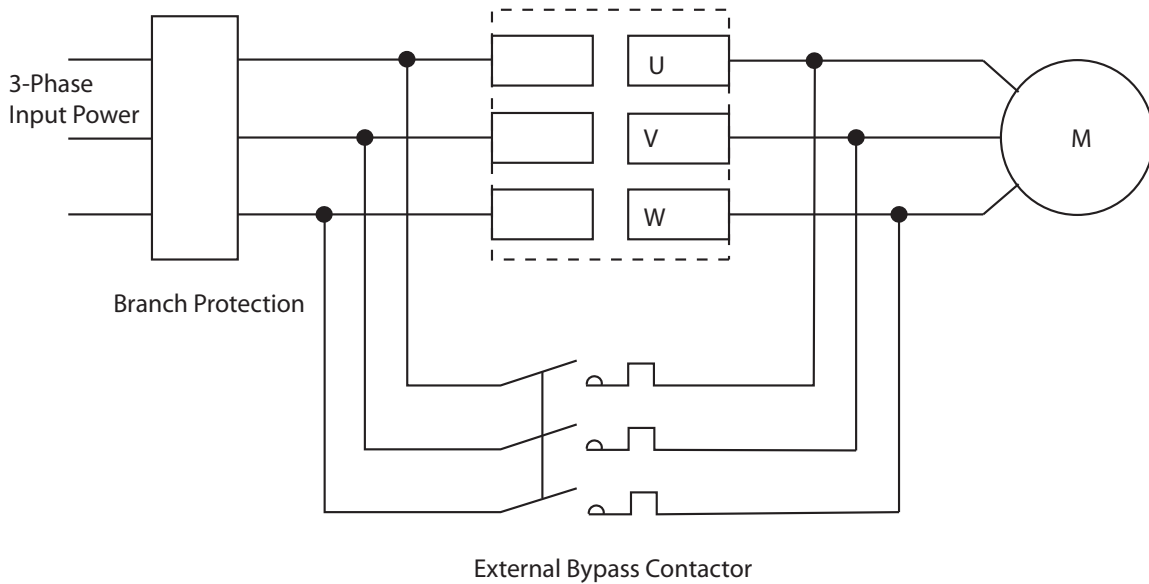
Figure 6 - Soft Starter with External Bypass Contactor

Note: The internal bypass is typically rated AC-1, not AC-3, because the bypass contactor never makes or breaks current. If an external bypass is used for emergency run (not using the soft start for control), an AC-3 utilization rating is needed.

How does a VFD work?

Essentially, a VFD takes AC line voltage, converts it to a DC voltage, filters the DC voltage, and then inverts the signal back. That RMS value of this inversion simulates an AC voltage. The output frequency of the drive is usually from 0 to AC input line frequency. Higher frequencies than the nominal AC are also possible when required for certain applications. Rockwell Automation offers many variations of drives from volts per Hertz, the most common, to complex Vector Control, which provides excellent low speed/zero speed performance and delivers accurate torque and speed regulation.

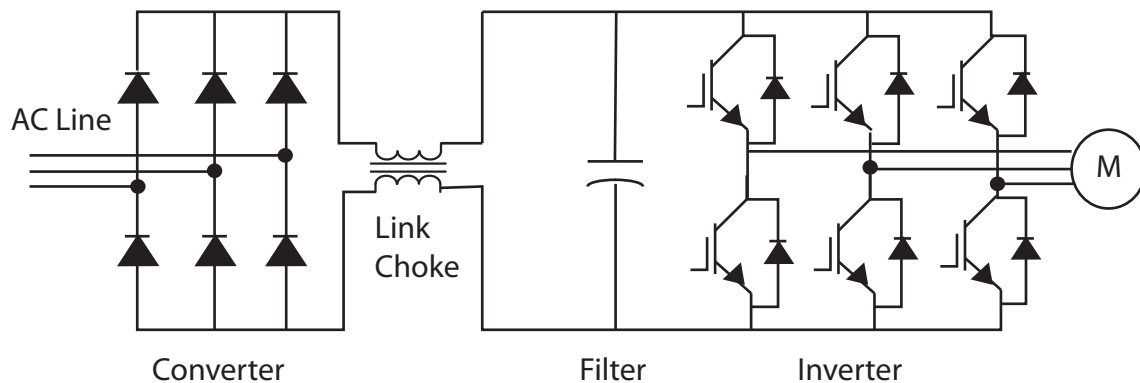
Figure 7 - Basic VFD Function

Most AC drives use a full wave diode-bridge or SCR rectifier bridge in the converter section to convert the AC source to DC voltage. Active components, such as insulated-gate bipolar transistor (IGBT) can also be used in this section. The filter section, primarily a capacitor bank, is used to smooth out the DC voltage that is produced from the converter section. A link choke or inductor can be added to improve power factor and reduce harmonics. The smoothed out DC voltage is then

used by the IGBT inverter. The fast-acting switching from the inverter section generates the proper RMS simulated AC voltage levels.

[Figure 8](#) illustrates the Pulse Width Modulated (PWM) technology that is used by most drives. The volts per Hertz ratio varies proportionally with the width of the pulses.

Figure 8 - Pulse Width Modulated Technology

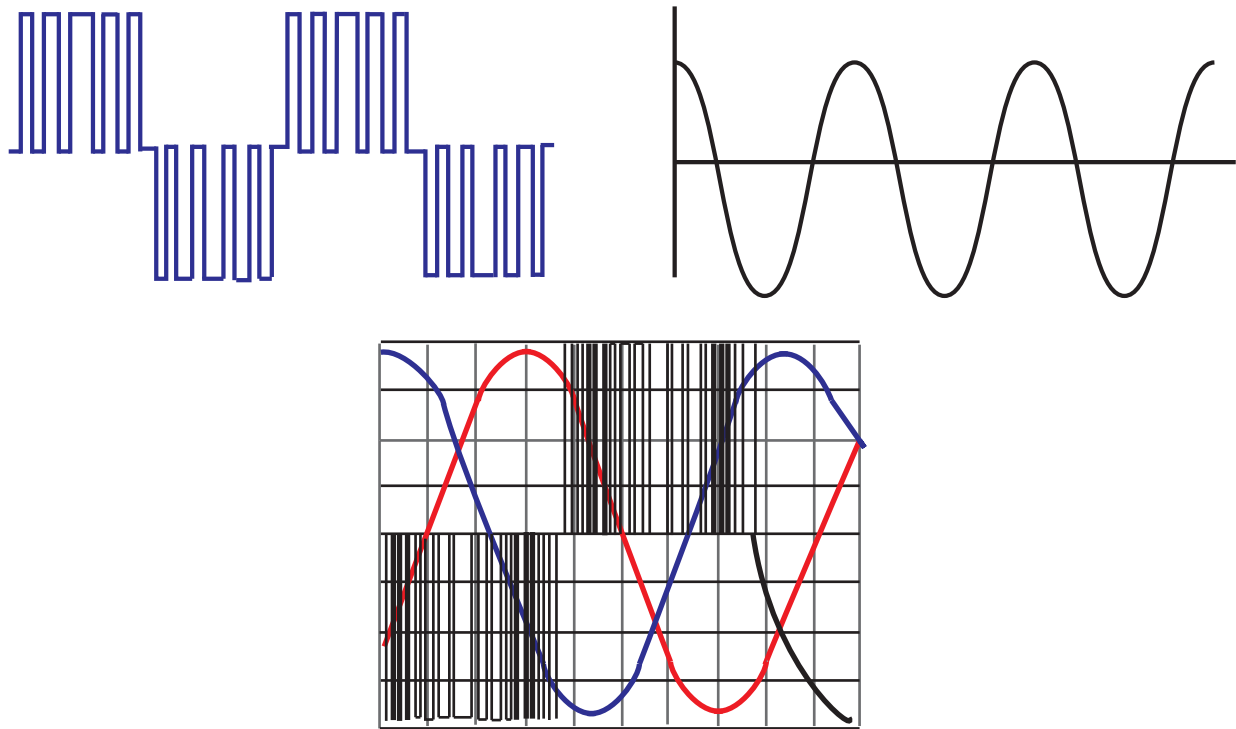

Drives can allow for motor rated torque to be accomplished from 0 to base speed without the use of increased or excessive current.

Comparisons

Efficiency

Soft Starter

Soft starters can achieve up to 99.5...99.9% efficiency. Typically, less than 1V is dropped across an SCR. Efficiency is dependent upon the size of the soft starter and the 3-phase voltage applied. After the starting process is complete, a soft start with integrated bypass, as with the SMC-3 and SMC Flex, pulls in an internal bypass contactor. The SCRs are no longer firing and all running current is across the contacts maintaining or improving efficiency. When operating at full speed and properly loaded, soft starters are more efficient than VFDs.

The SMC-50 has a parameter setting to allow energy consumption efficiency when a motor is in an unloaded condition; this setting could potentially save energy costs. The soft starter has the CE mark and should not need extra filtering for harmonics. Other soft starters may not have the CE mark and may need filtering.

Drive

Drives are typically 95 ...98 % efficient. During start, run, and stop (unless set to coast stop), active components such as IGBTs are on. However, certain drives are better able to adjust power consumption during running mode. Select the drive based on different load characteristics, and you could potentially save energy costs. The higher the pulses in the drive, the higher the efficiency. For example, a 6-pulse drive is 96.5...97.5 % efficient. An 18-pulse drive is 97.5...98 % efficient.

Heat from Soft Starter or Drive

Soft Starter

In a soft starter with integrated bypass, current is carried across the contactor, therefore no active solid-state components are on to generate more heat.

Figure 9 - Soft Starter with Integrated Bypass

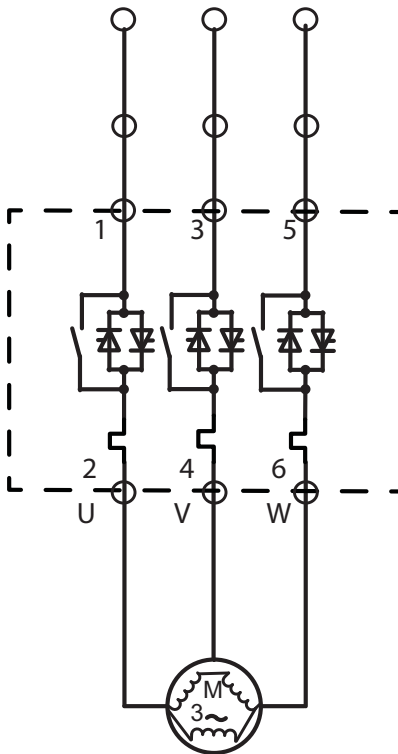

Drive

When running, a VFD is inherently hotter than the soft starter due to active components constantly controlling frequency and voltage.

Note: A motor is most efficient when loaded between 50% and 100%. Below this load level, efficiency significantly drops off. [Figure 10](#) shows typical NEMA motor efficiencies based on motor load.

Figure 10 - Typical Efficiency Versus Load Curves for 1800 RPM Three-Phase 60 Hertz Design B Squirrel-cage Induction Motors

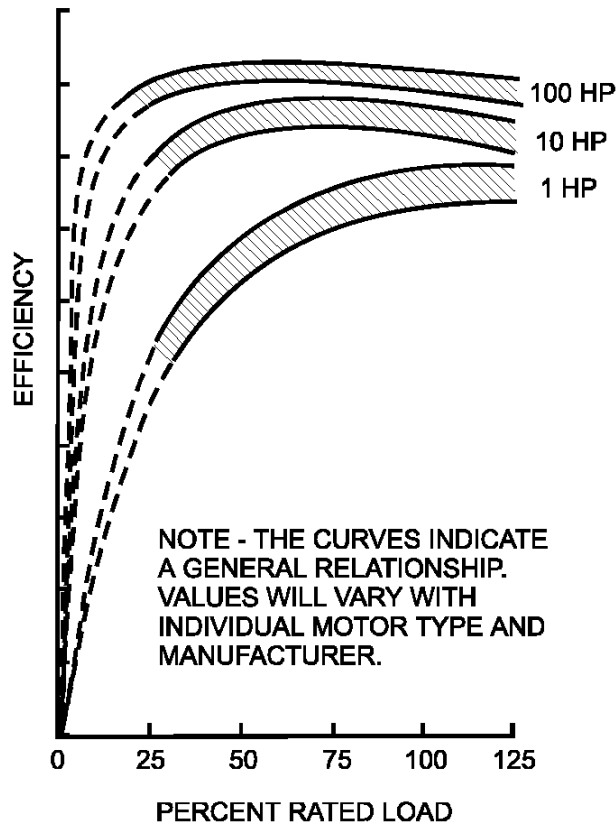

Wye-delta (Starting Inside the Delta) Motors

Figure 11 - Soft Starter with Wye-delta Wiring

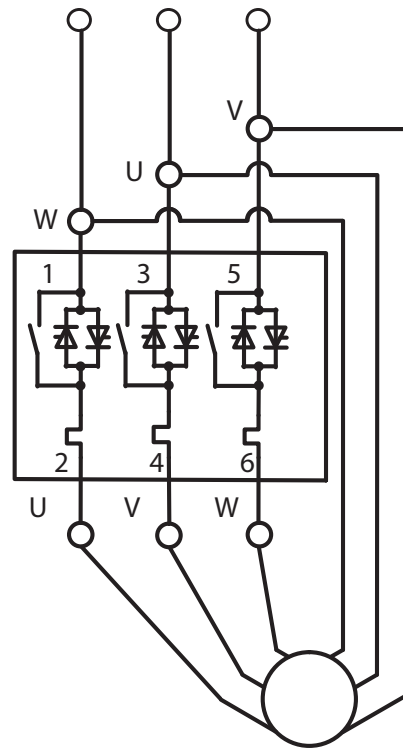

Soft Starter

This wiring configuration allows the use of smaller soft starter to be selected to start six-lead motors inside the delta. For example, a 200 Hp (140 kW) line-connected motor would minimally use a 251 A unit. A 200 Hp (140 kW) wye-delta motor would minimally use a 201 A unit, which saves cost and possibly reduces footprint size. You can find more information about wye-delta starting in the SMC Wye-Delta white paper, Rockwell Automation publication 150-WP004.

Drive

Drives are sized for line connection (three leads from the motor), based on full load current of the motor.

Communication Capabilities for Monitoring and Control

Both the Allen-Bradley soft starter and the VFD offer a variety of control options, including Modbus, Ethernet, ControlNet™, DeviceNet™, and PROFIBUS™.

Harmonics, Wiring Methods and Installation Considerations

Soft Starter

Soft starter harmonics are typically less than 10% in starting or stopping modes when SCRs are turned on and provide partial voltage amplitudes, producing partial sine waves. With the motor at full speed, the SCRs are fully conducting, there are virtually no harmonics. In bypass condition, there are almost no harmonics generated.

Long cable/wire runs with the soft starter product typically do not need any special treatment other than having properly sized cable/wire to compensate for the voltage drop. The Allen-Bradley soft starts typically have runs up to 762 meters (2500 feet) based on the capacitance of the cable, which was factored into the design. No special wire or wire type is needed. Soft starters do not typically require EMC mitigation to meet IEC harmonics requirements. IEC requirements pertain to the full-on running state of the soft starter.

Drive

Long cable/wire runs from a drive to a motor can create reflected wave issues. It is recommended to use line reactors to prevent harmonics from feeding back onto the power source and causing voltage distortions harmful to other equipment. Other devices that are used to help reduce harmonics in drives are DC link chokes, passive filters, 12-pulse converter with phase-shifting transformer, active filter, active (regenerative) converter and 18-pulse converter. You must also consider wire type when you install drives.

Starting and stopping time accuracy

Soft Starter

Soft starters are load dependent and based on programmed start and stop settings. An algorithm adjusts voltage to increase the current and torque to start the motor. Based on the back electromotive force (EMF) of the motor, the soft starter determines whether the motor is up to speed. If the soft starter detects that the motor is up to speed before the selected timed start, the soft starter applies full voltage and indicates running status. If the motor does not come up to speed in a set time frame, the soft starter applies full voltage (SMC Flex, SMC-50) or a percentage of the full voltage (SMC-3), depending on load. The exception is the SMC-50 in linear start and linear stop control, where a special algorithm, without the use of an external tachometer, allows accurate starting and stopping times with a few parameter selections, regardless of the load.

Drives

Speed control is precisely provided by drives including start and stop times, depending on the drive that is selected and the loading and overload capability of the drive.

Figure 12 - Preset Slow Speed

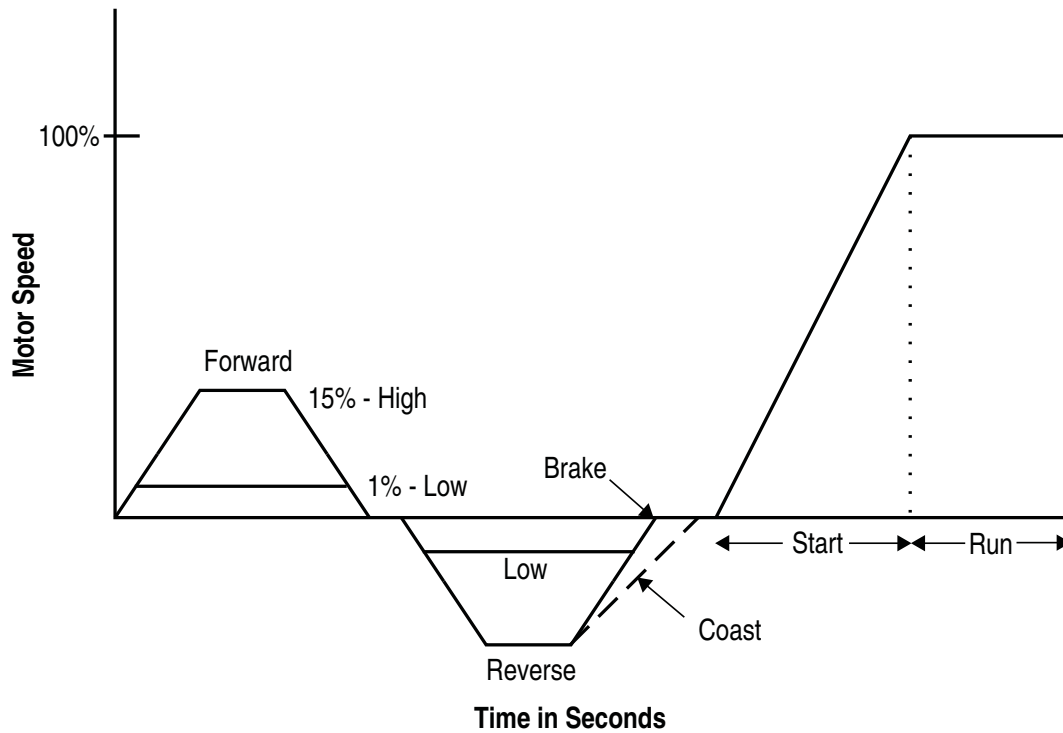

Speed control

Soft Starter

Some soft starters have limited slow speed control between starting and stopping, shown in [Figure 12](#). The SMC Flex offers two fixed slow speeds forward, 7% and 15%, and two fixed slow speeds in reverse, 10% and 20%. The SMC-50 offers adjustable speeds from 1% to 15% of full speed in both forward and reverse without using a reversing contactor. For example, an 1800 rpm motor has available slow speeds of 18...270 rpm in both forward and reverse directions. The slow speed control is functional in duration of minutes due to temperature rise in the SCR and the motor. Reaching the slow speed looks similar to creating PWM waveforms, shown in [Figure 13](#).

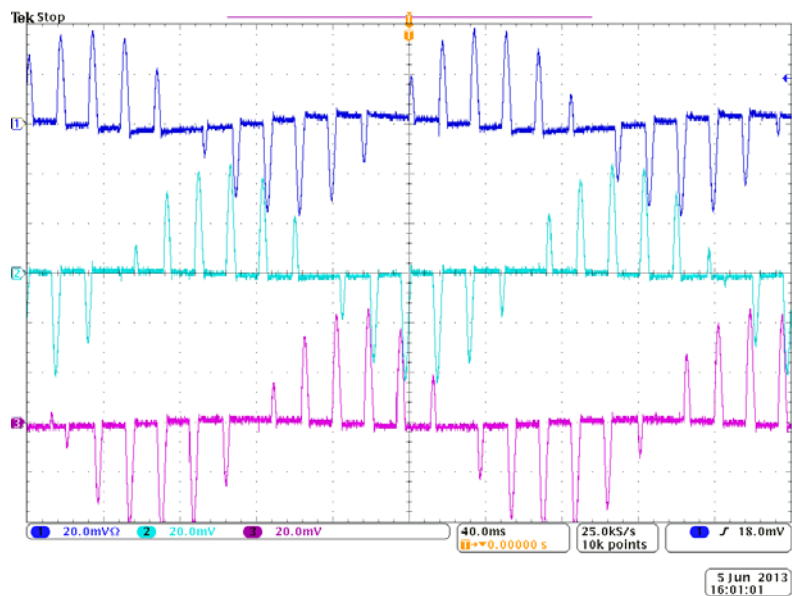
Figure 13 - SMC-50 Slow Speed Waveform

Drive

Drives offer continuous and fully adjustable speed any time from starting to stopping for possibly hours, due to the ability of adjusting the frequency.

Although both the drive and the soft starter can run at slow speeds, the duration of each is dependent on the motor and the load. Heat from running a motor at slow speeds depends on time. In order to protect the SCRs and the motor, the soft starter will reach thermal capacity if left in slow speed for too long. Continuous operation of a drive below 5 Hz requires de-rating.

Full torque at 0 speed

Soft Starter

Soft starters operate on a fixed frequency, and full torque is available only at full voltage. Initial torque is programmed into the soft starter. The associated voltage for the torque setting is the starting point of the ramp. Full torque is not available at zero speed.

Drive

In drive applications, 100% torque is available up to line frequency at base speed. Above base motor speed, horsepower is 100% and torque decreases. Holding torque is an advantage that a drive provides on applications like an incline conveyor that holds the belt with the load from moving backward when stopped. The application will determine whether other safety features are needed in addition to full torque at zero speed with a drive. A soft starter would need to use a mechanical brake to achieve the same function.

Initial Cost

At lower amperage, the drive and the soft starter have similar costs, but as the amperage and power go up, so does the cost of a drive. [Figure 14](#) and [Figure 15](#) show the initial cost comparisons of an IEC and NEMA starter to a soft starter and drive.

Figure 14 - Soft Starter, IEC Starter and VFD Cost Comparison

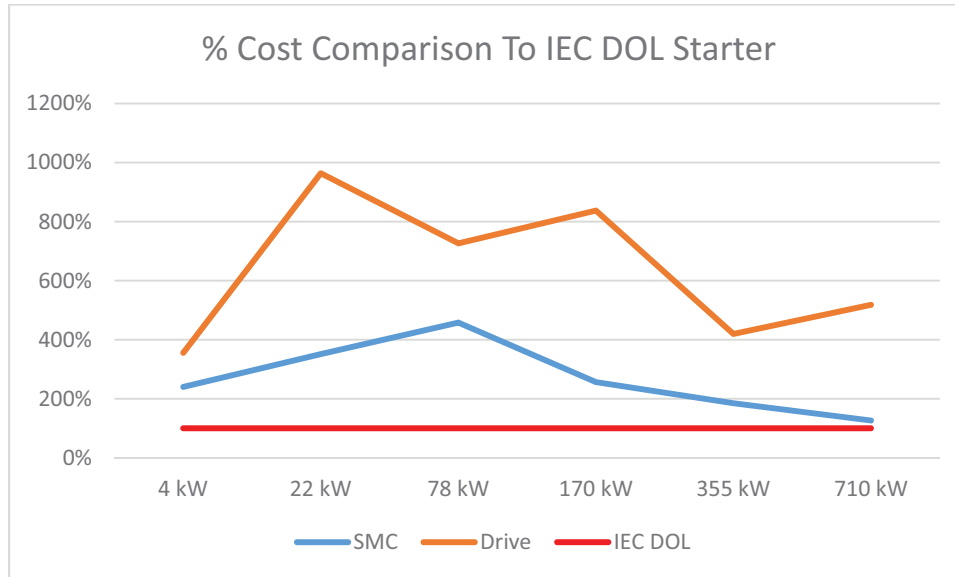
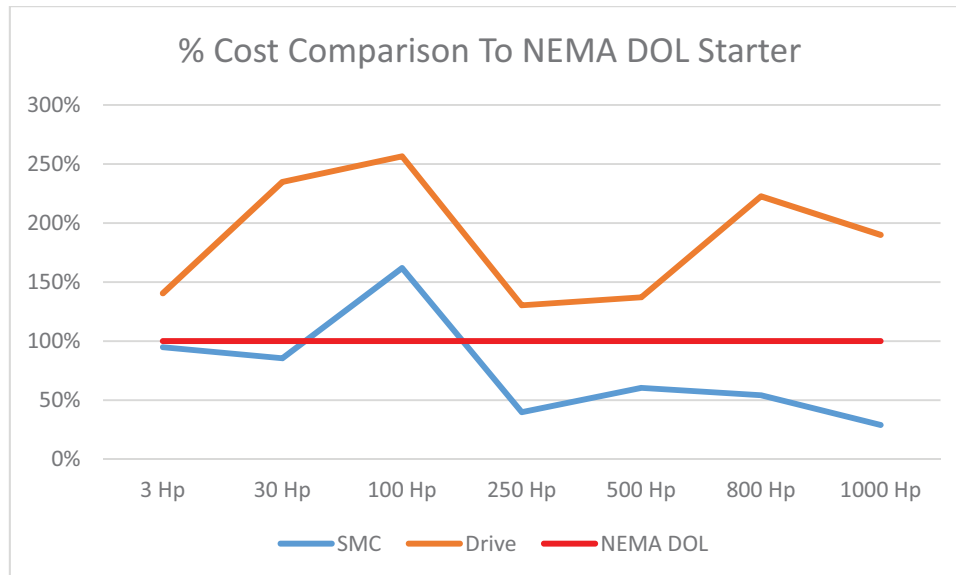

Figure 15 - Soft Starter, NEMA Starter and VFD Cost Comparison



Physical Size

[Figure 16](#) and [Figure 17](#) show the relative size difference between a drive and a soft starter, where the soft starter is smaller than the drive. Large-size drives must be mounted in a motor control center-style cabinet, because other devices (for example, isolation, inverters and EMC limiters) are also being mounted along with the drive.

Figure 16 - Soft Starter, IEC Starter, and Drive Physical Size Comparison at 400V AC, 3-phase

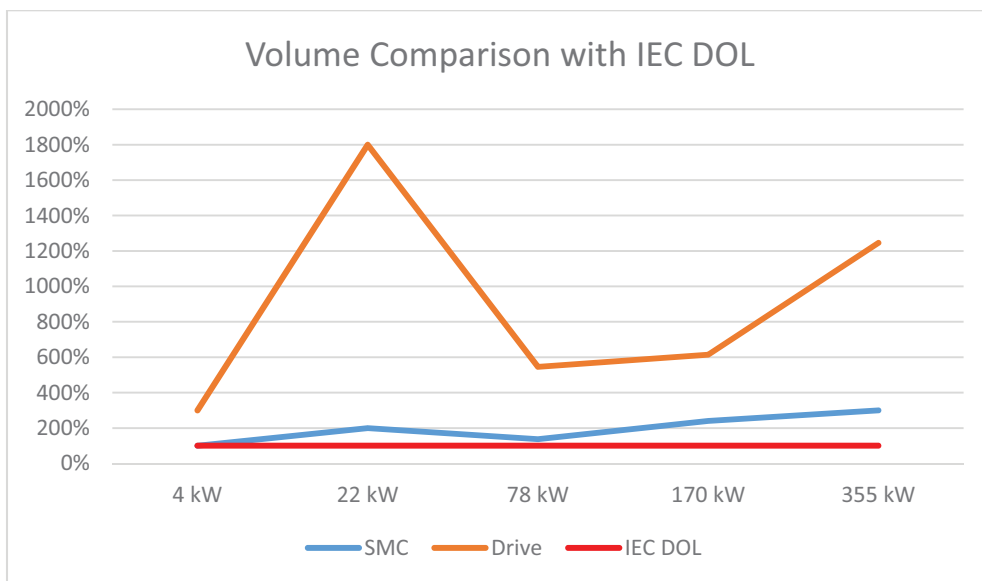
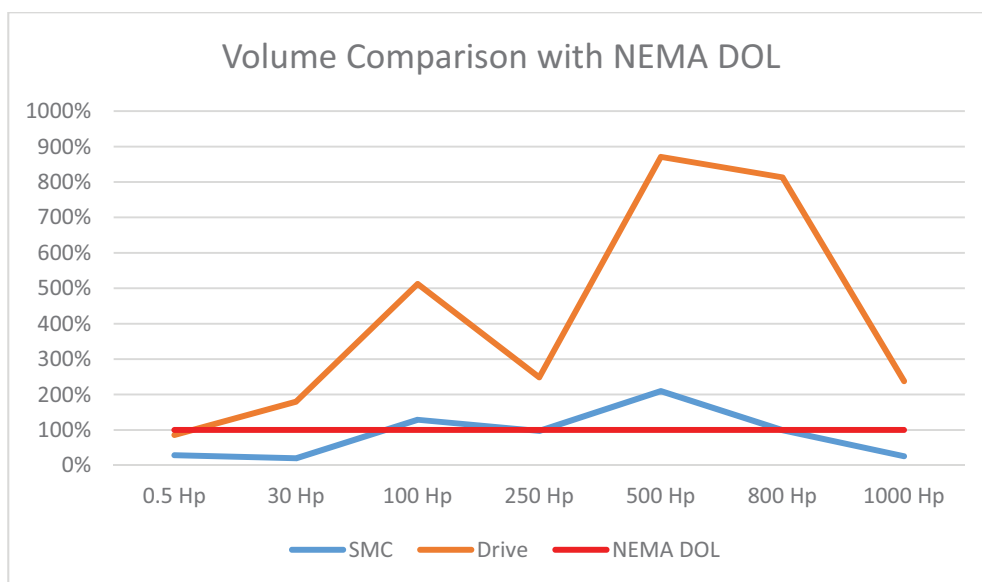

Figure 17 - Soft Starter, NEMA Starter, and Drive Physical Size Comparison at 480V AC, 3-phase



Maintenance

Soft Starter

Little maintenance is required for the soft starter other than keeping the fan vents clear and clean.

Drive

Depending on the drive, annual maintenance or even less frequently, parts need to be inspected, cleaned and or replaced. For example, on a drive operating 24 hours per day, in year 3, you should replace the following (if applicable):

- cooling fan motor
- small cooling fans
- de-ionizing filter cartridge
- coolant
- electrolytic bus capacitors
- rectifier bus capacitors
- inverter snubber capacitors
- integrated gate driver power supply
- AC/DC and DC/DC power supplies
- UPS batteries

Starting and Stopping Options

Multiple Starting Profiles

Soft Starter

Two different programmed starts can be used. For example, you might need different starting options for cold and hot days. With the SMC-50 and linear acceleration, there is no need for two different programmed starts. Linear acceleration adjusts to the load, eliminating the need for two programmed starts.

Drive

VFDs are very versatile, and have multiple brake points, multiple speed adjustments, and control from start to stop.

Single or 3-phase Operation

Soft Starter

- Protected with built-in overloads
- SCRs control all three phases
- Typically available in 3-phase configuration only

Drive

- Single- and 3-phase configurations are available
- Single-phase input requires substantial derating

Timed Starts

Soft Starter

Start times up to 30 seconds are typical, however most of the soft starters have some capabilities beyond 30 seconds, and up to 999 seconds. Long start times are not normal, and the thermal capabilities of the system, including the motor, should be considered.

Drive

Acceleration times can be set out to 3600 seconds. Extended times are usually associated with high inertia loads, reducing the size of the drive required.

Stopping Options

Soft Starter

- Coast (no control stop)
- Smart motor braking (ability to stop a motor faster than coast without the use of external brake)
- Pump stop (control of pump stopping, preventing water hammer)
- Linear deceleration (accurate, controlled stop in a programmed time)
- Accu-stop (allows slow speed option to be used before coming to a complete stop for accurate placement of product)
- Soft stop (programmed stop to enable longer stopping time than provided by a coast).

Drive

- Coast
- Ramp
- Ramp to hold
- DC brake
- Dynamic braking⁽¹⁾
- Current limit
- Fast brake

(1) The use of dynamic brake resistors minimizes an overvoltage fault. You can use a digital input to select between two different stop modes.

Applications and Motors

While most motors can be used with a VFD or a soft starter, [Table 2](#) lists some exceptions.

Table 2 - Soft starter and VFD Application Exceptions

Application	Soft Starter	VFD
Positive displacement pumps	Possible ❶	Yes
Reversing	Yes ❷	Yes
Linear induction motors	Yes	Yes
Transformers	Yes	Yes ❸
Resistive loads	Yes	Yes ❸
Part winding	Yes	Yes ❸
Wound rotor	Yes	Yes ❸
Permanent magnet motors	No	Yes
Reluctance motors	No	Yes
High torque, low current	No	Yes

❶ Use the SMC E-tool estimation wizard to determine whether a soft starter will work

❷ Uses reversing contactors for full speed. Slow speed is done without contactors.

❸ In adjustable voltage mode.

Application Examples

Low-current Restrictions

Low-current restrictions, such as end of the utility power feed for a remotely located irrigation system, are common. For example, the power might be limited to under 200% of the motor nameplate without putting stress on the power source. Motors need enough torque to overcome the load torque demand, so remember to consider factors like motor sizing to the load and type of motor.

A soft starter can limit the current to 200%, doing so also limits the amount of torque applied. Further investigation, using wizards, is used to help determine whether the current limit is enough to start the motor.

A drive can provide higher torque levels while remaining below the current requirement of the power distribution system.

Fans

Almost any application that uses constant running speed is appropriate for the soft starter. A large drying fan in a factory that runs all day at a constant speed once it is started is a good example. The soft starter can control the starting torque to the fan to provide a smooth start. Once at speed, no control is needed until a stop command is provided.

A large fan that varies the speed throughout the process, for example changing speed based on temperature, is controlled better by using a drive. A drive can control the speed any time during the process.

Conveyors

It is better to use a soft starter when you replace DOL starters to prevent material spillage or damage during starting and stopping on a conveyor. The soft starter smoothly starts and stops the conveyor without mechanical stress.

Pumps

Pump applications can use either a drive or a soft starter. The soft start can reduce water hammer on both the start and the stop, and is usually less expensive. A drive can perform the same task, with the addition of being able to control the speed of the pump during the run mode.

Summary

Knowledge of your application determines which starting method you should use. Both the soft starter and the drive can start a motor with reduced voltage and current. The results produce less mechanical wear and maintenance from either device. While the soft starter has some slow speed capabilities (up to $\pm 15\%$ of slow speed), extensive speed control and long durations are best suited for a drive. Soft starters offers a bypass for cooler operation if only starting and stopping of the motor is needed. Other brands of soft starters may or may not offer features that are described in this publication. Drives can control speed anywhere throughout the process and adjust torque easily when needed when properly configured.

In summary, know your application, size restrictions, and your budget, and you will be better able to select the right device.

Table 3 - Soft Starter and VFD Application Summary

Feature	Soft Starter	Drive
Reduced voltage, current, and torque while starting	Yes	Yes
Slow speed capabilities	Limited	Yes
Wye-Delta connection	Yes	No
Does the application need precise starting and stopping times?	Limited	Yes
Size of controller	Smaller	Larger
Initial Cost	Lower	Higher
Full torque at 0 speed	No	Yes

Notes:

Important User Information

Read this document and the documents listed in the additional resources section about installation, configuration, and operation of this equipment before you install, configure, operate, or maintain this product. Users are required to familiarize themselves with installation and wiring instructions in addition to requirements of all applicable codes, laws, and standards.

Activities including installation, adjustments, putting into service, use, assembly, disassembly, and maintenance are required to be carried out by suitably trained personnel in accordance with applicable code of practice.

If this equipment is used in a manner not specified by the manufacturer, the protection provided by the equipment may be impaired.

In no event will Rockwell Automation, Inc. be responsible or liable for indirect or consequential damages resulting from the use or application of this equipment.

The examples and diagrams in this manual are included solely for illustrative purposes. Because of the many variables and requirements associated with any particular installation, Rockwell Automation, Inc. cannot assume responsibility or liability for actual use based on the examples and diagrams.

No patent liability is assumed by Rockwell Automation, Inc. with respect to use of information, circuits, equipment, or software described in this manual.

Reproduction of the contents of this manual, in whole or in part, without written permission of Rockwell Automation, Inc., is prohibited.

Documentation Feedback

Your comments will help us serve your documentation needs better. If you have any suggestions on how to improve this document, complete this form, publication [RA-DU002](#), available at <http://www.rockwellautomation.com/literature/>.

Allen-Bradley, Rockwell Software, Rockwell Automation, SMC, and LISTEN. THINK. SOLVE are trademarks of Rockwell Automation, Inc.
Trademarks not belonging to Rockwell Automation are property of their respective companies.

Rockwell Otomasyon Ticaret A.Ş., Kar Plaza İş Merkezi E Blok Kat:6 34752 İçerenköy, İstanbul, Tel: +90 (216) 5698400

www.rockwellautomation.com

Power, Control and Information Solutions Headquarters

Americas: Rockwell Automation, 1201 South Second Street, Milwaukee, WI 53204-2496 USA, Tel: (1) 414.382.2000, Fax: (1) 414.382.4444
Europe/Middle East/Africa: Rockwell Automation NV, Pegasus Park, De Kleetlaan 12a, 1831 Diegem, Belgium, Tel: (32) 2 663 0600, Fax: (32) 2 663 0640
Asia Pacific: Rockwell Automation, Level 14, Core F, Cyberport 3, 100 Cyberport Road, Hong Kong, Tel: (852) 2887 4788, Fax: (852) 2508 1846