

| BUL 103 & BUL 107 AUX CONTACTS FOR 140-CMN CIRCUIT BREAKERS |           |              |                       |                   |                   |
|---|-----------|--------------|-----------------------|-------------------|-------------------|
| Last Characters in Cat. No. (103S-KTD2-GC40CK)              |           | Aux Contacts | Trip Contacts         | Terminal Markings |                   |
| 1 st CHAR   | 2 nd CHAR |              |                       | CB (1)            | CB (2)            |
| X   |           | --           | --                    | --                | --                |
| C   |           | 1 NO + 1 NC  | --                    | 13 - 14           | 21 - 22           |
| D   |           | 2 NO         | --                    | 13 - 14           | 23 - 24           |
| C,D   | K         | 1 NO         | 1 NC (SC) + 1 NC (OL) | 13 - 14           | 41 - 42 + 35 - 36 |
| C,D   | L         | 1 NO         | 1 NO (SC) + 1 NO (OL) | 13 - 14           | 43 - 44 + 37 - 38 |

| BUL 103 & BUL 107 AUX CONTACTS FOR 140M CIRCUIT BREAKERS |           |              |                |                   |         |
|--|-----------|--------------|----------------|-------------------|---------|
| Last Characters in Cat. No. (103S-ATD2-DB40CK)           |           | Aux Contacts | Trip Contacts  | Terminal Markings |         |
| 1 st CHAR  | 2 nd CHAR |              |                | CB (1)            | CB (2)  |
| X  |           | --           | --             | --                | --      |
| B  | K,L,M,N,Q | 1 NO         | --             | 13 - 14           | --      |
| C  | K,L,M,N,Q | 1 NO + 1 NC  | --             | 13 - 14           | 21 - 22 |
| D  | K,L,M,N,Q | 2 NO         | --             | 13 - 14           | 23 - 24 |
| S  | K,L,M,N,Q | 1 NO         | 1 NO (SC + OL) | 13 - 14           | 27 - 28 |

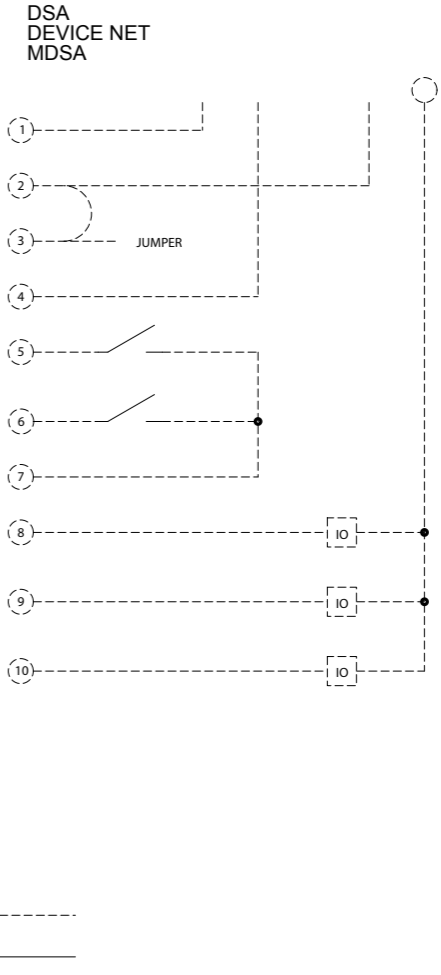
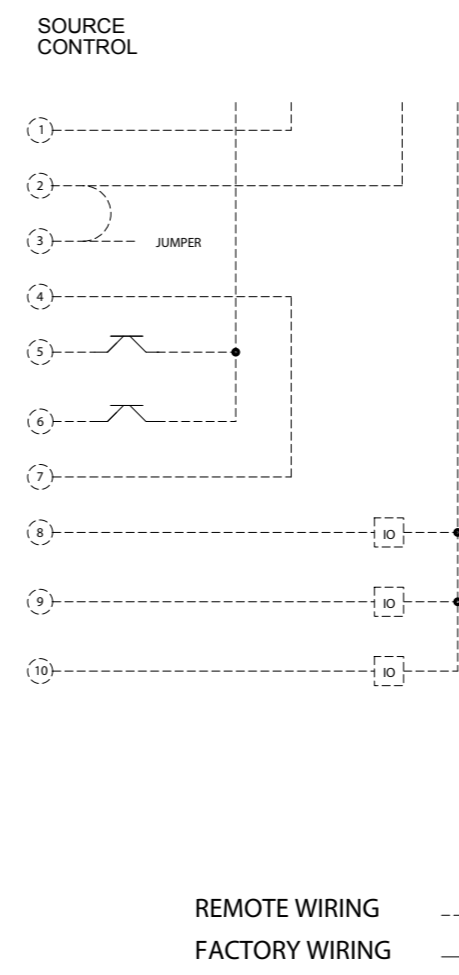
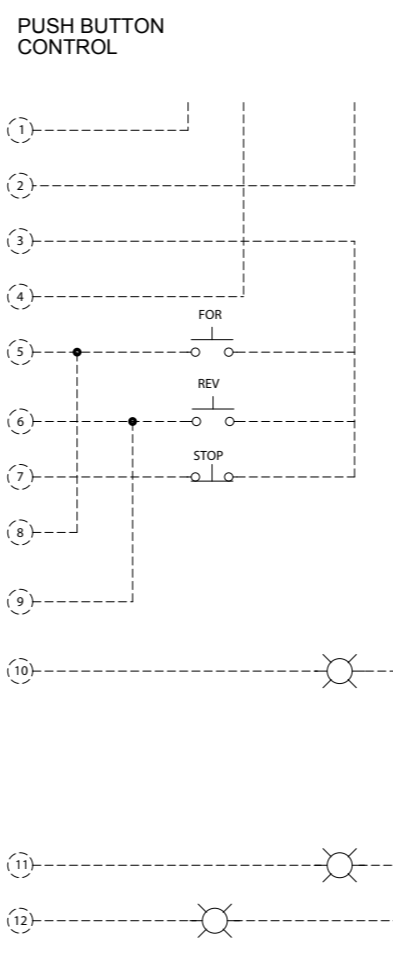
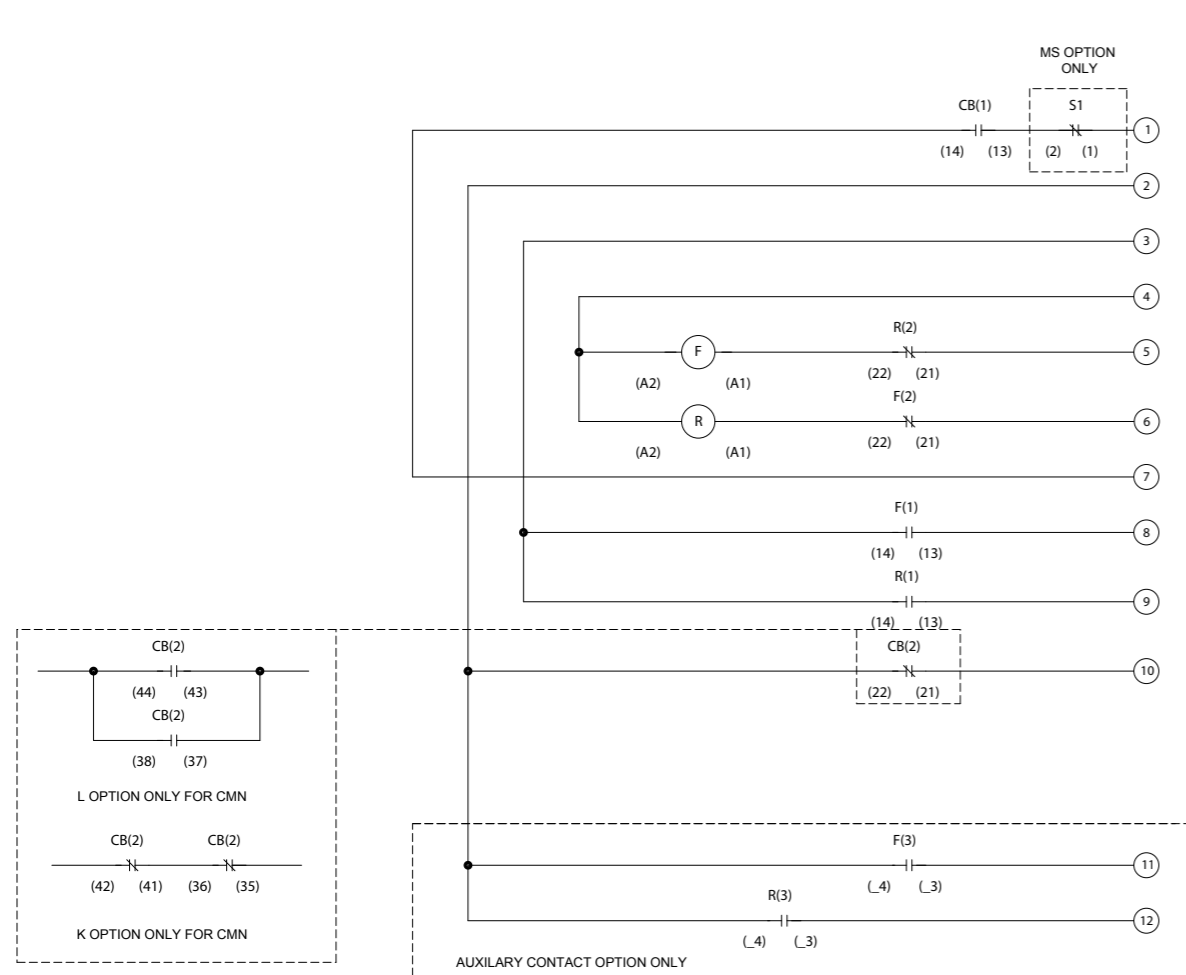
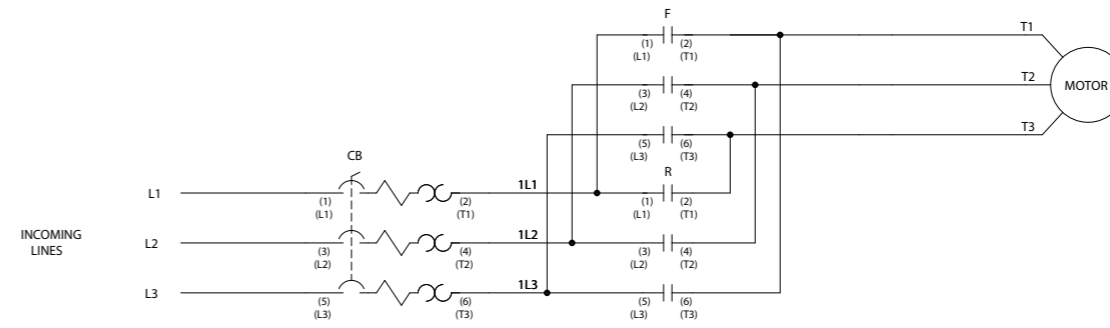

REMOTE WIRING -----  
 FACTORY WIRING \_\_\_\_\_

| BUL 107 AUX. CONTACTS FOR 100C CONTACTORS        |             |               |         |         |         |         |         |         |         |               |         |         |         |         |         |         |         |
|--|-------------|---------------|---------|---------|---------|---------|---------|---------|---------|---------------|---------|---------|---------|---------|---------|---------|---------|
| 8th character in Cat. No. i.e. (107S-ATA3-CA16C) | Description | 100-C09...C23 |         |         |         |         |         |         |         | 100-C30...C85 |         |         |         |         |         |         |         |
|  |             | F(1)*         | F(2)**  | F(3)    | F(4)    | R(1)*   | R(2)**  | R(3)    | R(4)    | F(1)          | F(2)    | F(3)    | F(4)    | R(1)    | R(2)    | R(3)    | R(4)    |
| 3  | 1NO + 1NC   | 13 - 14       | 21 - 22 | ---     | ---     | 13 - 14 | 21 - 22 | ---     | ---     | 13 - 14       | 21 - 22 | ---     | ---     | 13 - 14 | 21 - 22 | ---     | ---     |
| 7  | 2NO + 2NC   | 13 - 14       | 21 - 22 | 53 - 54 | 61 - 62 | 13 - 14 | 21 - 22 | 53 - 54 | 61 - 62 | 13 - 14       | 21 - 22 | 31 - 32 | 43 - 44 | 13 - 14 | 21 - 22 | 31 - 32 | 43 - 44 |

\* 4th Pole of Contactor  
 \*\* Mechanical/Electrical Interlock