

BUL 103 & BUL 107 AUX CONTACTS FOR 140-CMN CIRCUIT BREAKERS					
Last Characters in Cat. No. (103S-KTD2-GC40CK)		Terminal Markings			
1 st CHAR	2 nd CHAR	Aux Contacts	Trip Contacts	CB (1)	CB (2)
X		--	--	--	--
C		1 NO + 1 NC	--	13 - 14	21 - 22
D		2 NO	--	13 - 14	23 - 24
C,D	K	1 NO	1 NC (SC) + 1 NC (OL)	13 - 14	41 - 42 + 35 - 36
C,D	L	1 NO	1 NO (SC) + 1 NO (OL)	13 - 14	43 - 44 + 37 - 38

BUL 103 & BUL 107 AUX CONTACTS FOR 140M CIRCUIT BREAKERS					
Last Characters in Cat. No. (103S-ATD2-DB40CK)		Terminal Markings			
1 st CHAR	2 nd CHAR	Aux Contacts	Trip Contacts	CB (1)	CB (2)
X		--	--	--	--
B	K,L,M,N,Q	1 NO	--	13 - 14	--
C	K,L,M,N,Q	1 NO + 1 NC	--	13 - 14	21 - 22
D	K,L,M,N,Q	2 NO	--	13 - 14	23 - 24
S	K,L,M,N,Q	1 NO	1 NO (SC + OL)	13 - 14	27 - 28

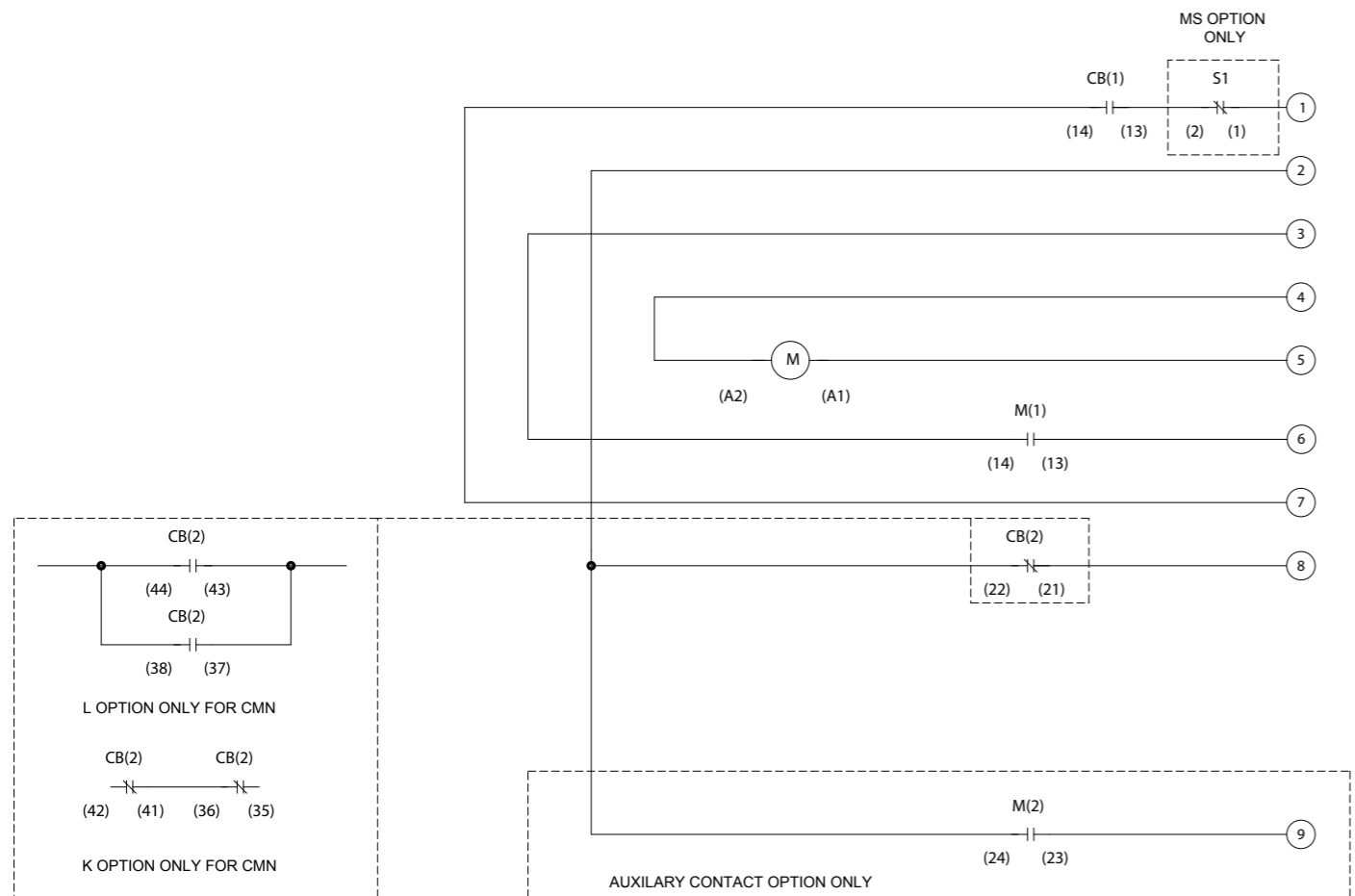

**PUSH BUTTON CONTROL**

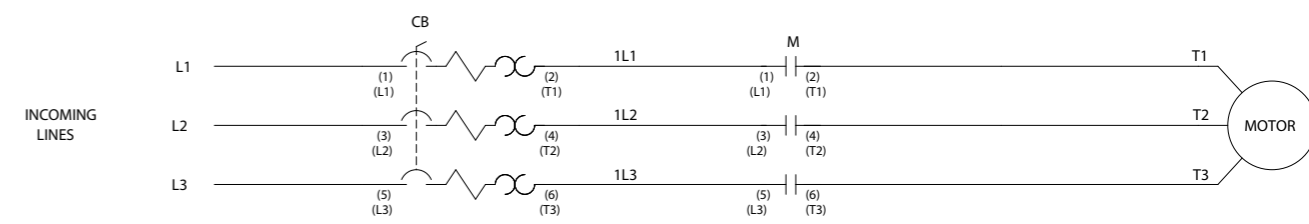
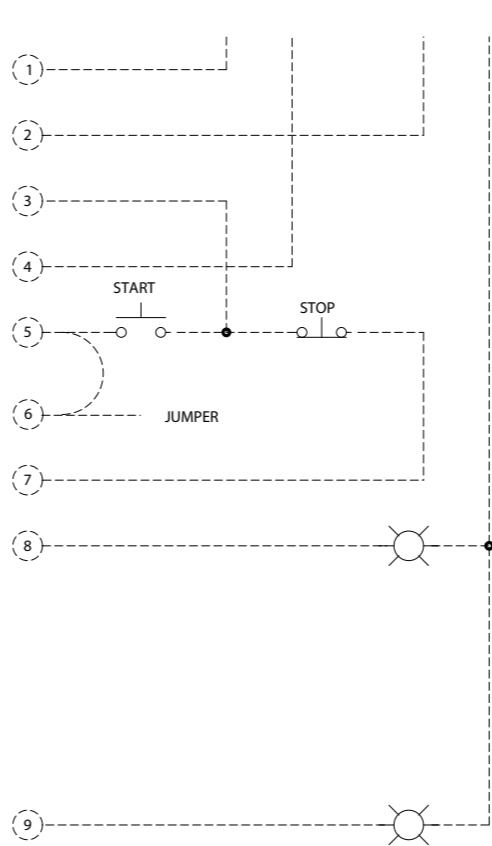

**SOURCE CONTROL**

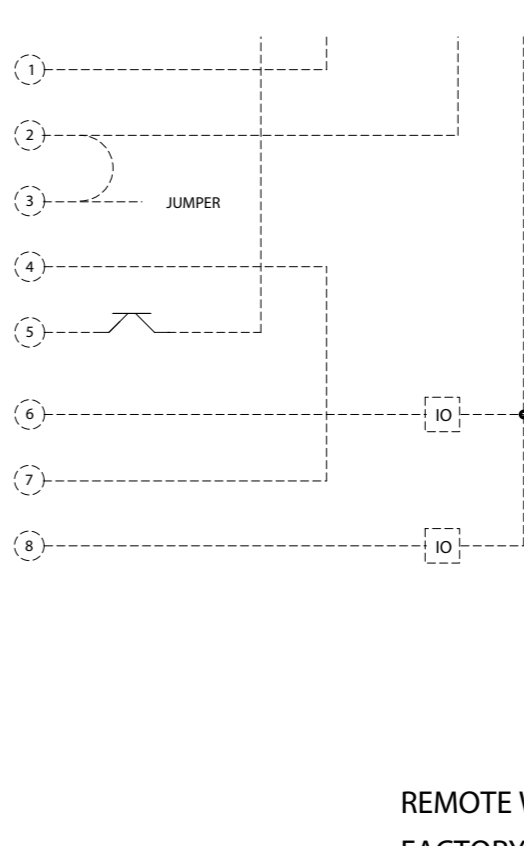

**DSA DEVICE NET MDSA**

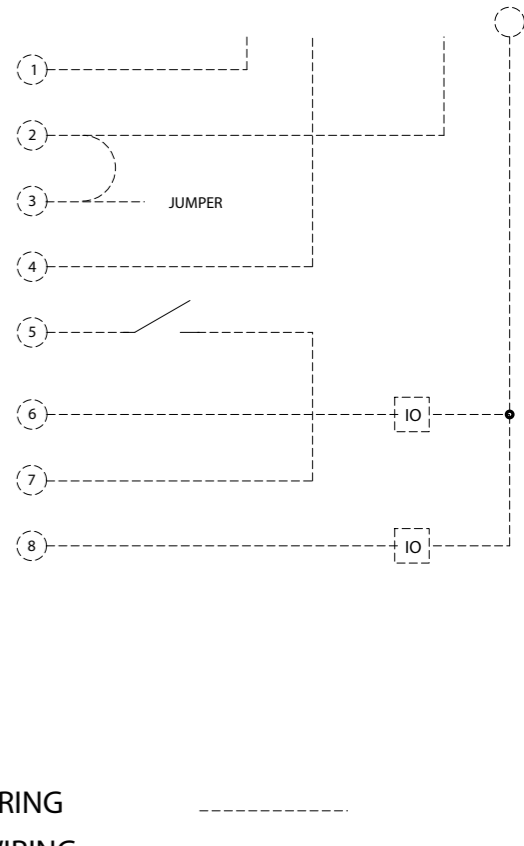

REMOTE WIRING -----  
 FACTORY WIRING \_\_\_\_\_

BUL 103 AUX. CONTACTS FOR 100C CONTACTORS											
8th character in Cat. No. i.e. (103S-ATA2-CA16C)	Description	100-C09...C23					100-C30...C85				
		M(1)*	M(2)	M(3)	M(4)	M(5)	M(1)	M(2)	M(3)	M(4)	M(5)
2	1NO	13 - 14	---	---	---	---	13 - 14	---	---	---	---
3	1NO + 1NC	13 - 14	21 - 22	---	---	---	13 - 14	21 - 22	---	---	---
4	2NO	13 - 14	3 - 4	---	---	---	13 - 14	23 - 24	---	---	---
6	2NO + 1NC	13 - 14	3 - 4	1 - 2	---	---	---	---	---	---	---
7	2NO + 2NC	---	---	---	---	---	13 - 14	21 - 22	31 - 32	43 - 44	---
8	3NO + 2NC	13 - 14	21 - 22	31 - 32	43 - 44	53 - 54	---	---	---	---	---

\* 4th Pole of Contactor