



Bulletin 1336 FORCE GT1/GT2 Circuit Board Options

Installation Data

General

This publication is intended to provide you with instructions for installing either a GT1 option (PLC Comm Adapter Board) or a GT2 option (Standard Adapter Board) in a 1336 FORCE shipped originally as a GT0 option with no communication board.

Precautions



ATTENTION: Severe injury or death can result from electrical shock, burn, or unintended actuation of controlled equipment. Hazardous voltages may exist in the cabinet even with the circuit breaker in the off position. Multiple sources of power may be connected to the 1336 FORCE. Recommended practice is to disconnect and lock out control equipment from all power sources and discharge stored energy in capacitors, if present. If it is necessary to work in the vicinity of energized equipment, the safety related work practices of NFPA 70E, Electrical Safety Requirements for Employee Workplaces, must be followed. DO NOT work alone on energized equipment!



ATTENTION: This Drive contains ESD (Electrostatic Discharge) sensitive parts and assemblies. Static Control precautions are required when installing, testing, servicing or repairing this assembly. These precautions should be applied when working with the logic boards AND any components in the power section. Component damage may result if ESD control procedures are not followed. If you are familiar with static control procedures, reference A–B publication 8000–4.5.2, *Guarding Against Electrostatic Damage* or any other applicable ESD Protection Handbook.

Necessary Tools & Equipment

The following tools & equipment must be available before starting a GT1/GT2 installation:

1. Assorted screwdrivers (Phillips and Straight).
2. Wrist grounding strap.

GT1 Option Installation

To convert a 1336 FORCE Drive from a GTO option to a GT1 option (PLC Comm Board) the following steps must be followed:

1. Disconnect and lock out all power to the Drive .
2. Remove the HIM holder cover and remove the 4 screws holding the HIM holder to the sheet metal. The HIM holder and cable must be removed to provide mounting space for the PLC Comm Board.
3. Place the PLC Comm Adapter board in position on the sheet metal (Fig.1) interfacing the PLC board connector J1 with the Motor Control Board connector J7. Fasten the board in place with the two supplied screws at the upper right and lower left corners.

Figure 1.
GT1 Option Board Installation (125 HP Version Shown)

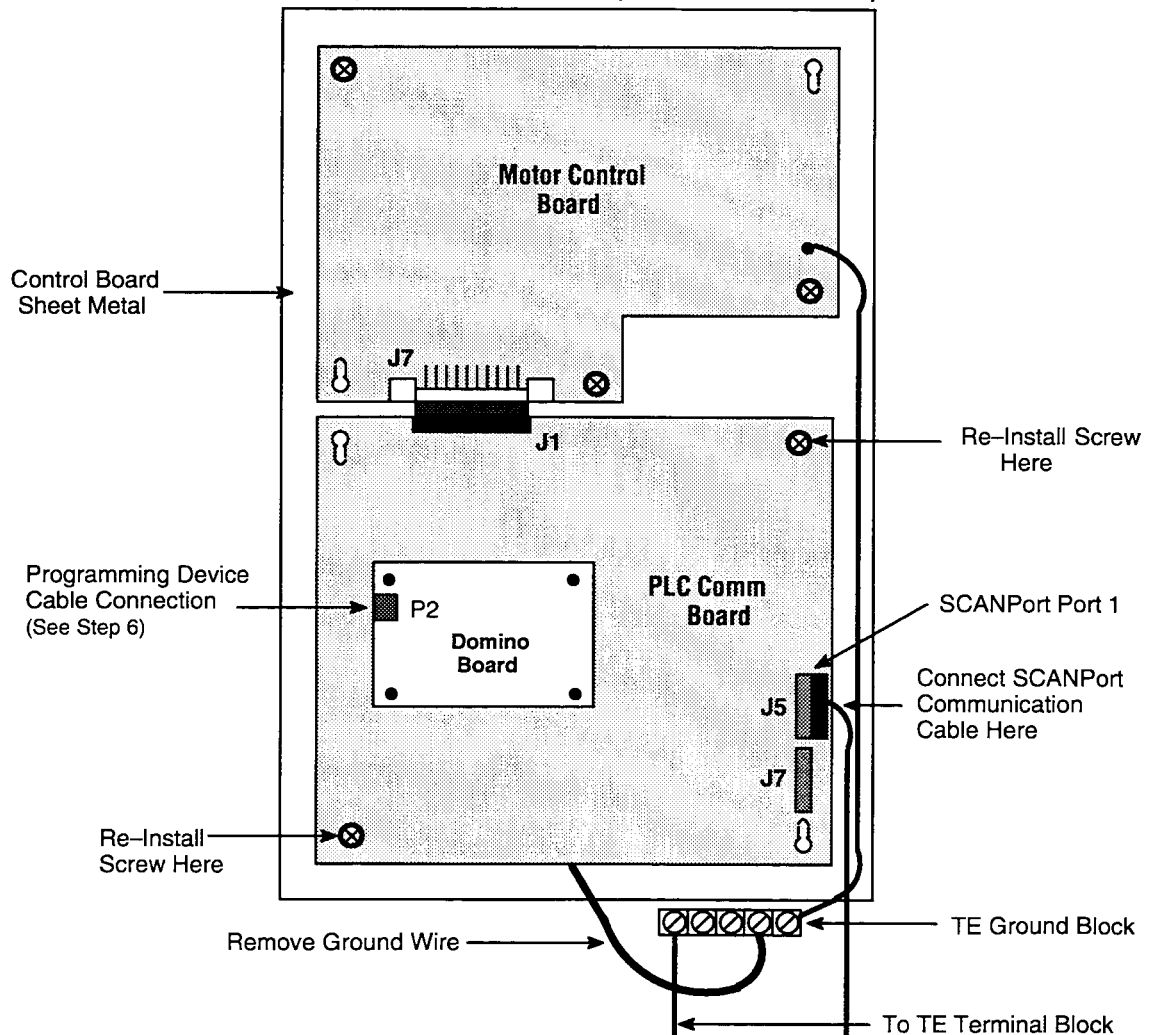

4. Remove the ground wire that originates on the TE Ground Block (Fig.1), discard it and replace with the new longer wire.
5. Install the SCANPort connector at Port 1 (J5) on the PLC Comm Board (Fig. 1).
6. If DriveTools is used as a programming device, it can be connected with a special cable to the Drive at P2 on the Domino Adapter Board (Fig 1).
7. Apply power to the drive, and perform an Initialize function through DriveTools or a programming device and enter the appropriate Motor/Drive setup data.

GT2 Option Installation

To configure a 1336 FORCE Drive with a GT2 option (Standard Adapter Board) the followings steps must be performed:

1. Disconnect and lock out all power to the Drive .

Figure 2.
GT2 Option Board Installation (125 HP Version shown)

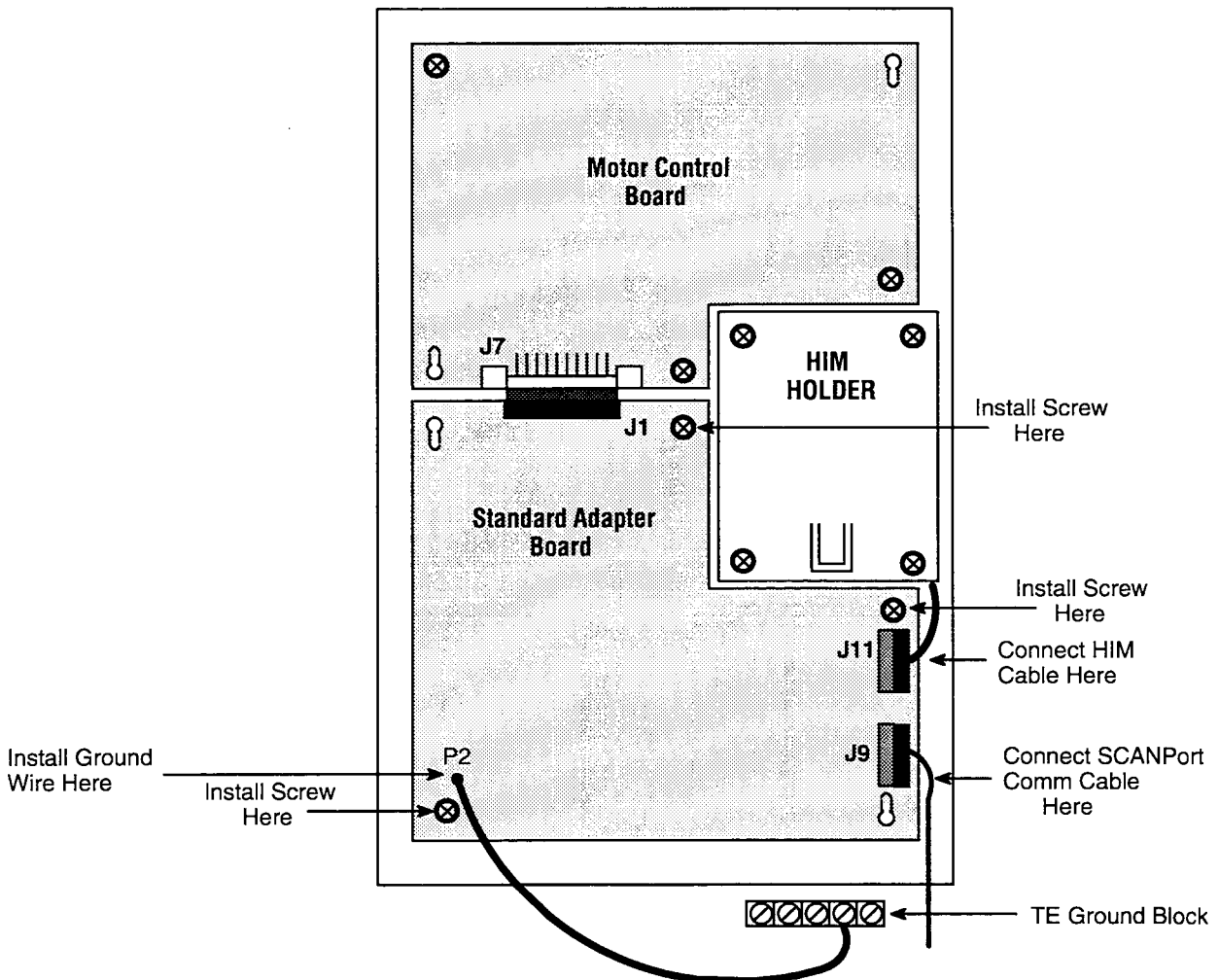

2. Place the Standard Adapter board in position on the sheet metal (Fig. 2) interfacing the Standard Adapter connector J1 with the J7 connector on the Motor Control Board. Fasten the board in place .
3. Connect the ground wire originating on the TE board to the P2 ground stud on the Standard Adapter Board (Fig. 2).
4. Install the HIM connector at J11, and the SCANPort Communication Cable at J9 on the Standard Adapter Board. (Fig. 2).
5. Apply power to the Drive, and perform an Initialize function through DriveTools or a programming device.



Allen-Bradley has been helping its customers improve productivity and quality for 90 years. We design, manufacture and support a broad range of control and automation products worldwide. They include logic processors, power and motion control devices, man-machine interfaces, sensors and a variety of software. Allen-Bradley is a subsidiary of Rockwell International, one of the world's leading technology companies.



With major offices worldwide.

Algeria • Argentina • Australia • Austria • Bahrain • Belgium • Brazil • Bulgaria • Canada • Chile • China, PRC • Colombia • Costa Rica • Croatia • Cyprus • Czech Republic • Denmark • Ecuador • Egypt • El Salvador • Finland • France • Germany • Greece • Guatemala • Honduras • Hong Kong • Hungary • Iceland • India • Indonesia • Israel • Italy • Jamaica • Japan • Jordan • Korea • Kuwait • Lebanon • Malaysia • Mexico • New Zealand • Norway • Oman • Pakistan • Peru • Philippines • Poland • Portugal • Puerto Rico • Qatar • Romania • Russia-CIS • Saudi Arabia • Singapore • Slovakia • Slovenia • South Africa, Republic • Spain • Switzerland • Taiwan • Thailand • The Netherlands • Turkey • United Arab Emirates • United Kingdom • United States • Uruguay • Venezuela • Yugoslavia

World Headquarters, Allen-Bradley, 1201 South Second Street, Milwaukee, WI 53204 USA, Tel: (1) 414 382-2000 Fax: (1) 414 382-4444