



Allen-Bradley

Technical Data

Compact Block LDX I/O for PROFIBUS DP

1790P, 1790



The CompactBlock™ I/O product family now offers you a new, more cost-effective I/O product line for light industrial and commercial automation environments.

CompactBlock LDX I/O utilizes PROFIBUS DP™ to translate simple messages from the controller to the plant floor. It is especially suitable where low cost and confined space is coupled with reduced environmental requirements.

Important User Information

Because of the variety of uses for the products described in this publication, those responsible for the application and use of these products must satisfy themselves that all necessary steps have been taken to assure that each application and use meets all performance and safety requirements, including any applicable laws, regulations, codes and standards. In no event will Rockwell Automation be responsible or liable for indirect or consequential damage resulting from the use or application of these products.

Any illustrations, charts, sample programs, and layout examples shown in this publication are intended solely for purposes of example. Since there are many variables and requirements associated with any particular installation, Rockwell Automation does not assume responsibility or liability (to include intellectual property liability) for actual use based upon the examples shown in this publication.

Allen-Bradley publication SGI-1.1, *Safety Guidelines for the Application, Installation and Maintenance of Solid-State Control* (available from your local Rockwell Automation office), describes some important differences between solid-state equipment and electromechanical devices that should be taken into consideration when applying products such as those described in this publication.

Reproduction of the contents of this copyrighted publication, in whole or part, without written permission of Rockwell Automation, is prohibited.

CompactBlock LDX I/O Blocks

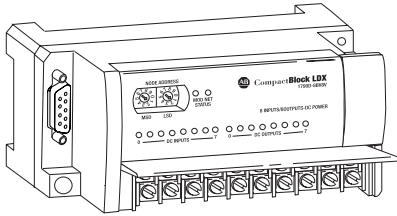

Base block with screw terminations

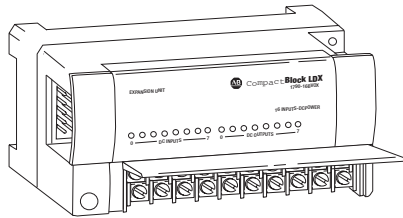

Expansion block with screw terminations

The following CompactBlock LDX I/O for PROFIBUS DP base and expansion blocks are available with screw terminations (terminal blocks):

Terminal Base Blocks	Description
1790P-T8BV8B	24VDC, 8 universal input/8 sourcing output base block
1790P-T8BV8V	24VDC, 8 universal input/8 sinking output base block
1790P-T0W6	6 relay output base block
1790P-TN4C0	4 channel analog current input block
1790P-TN0C2	2 channel analog current output block
1790P-T4R0	4 channel input RTD base block
1790P-T4T0	4 channel input Thermocouple base block
Digital Expansion Blocks	Description
1790-T16BV0X	24VDC, 16 universal input expansion block
1790-T8BV8BX	24VDC, 8 universal input/8 sourcing output expansion block
1790-T8BV8VX	24VDC, 8 universal input/8 sinking output expansion block
1790-T0B16X	24VDC, 16 sourcing output expansion block
1790-T0V16X	24VDC, 16 sinking output expansion block
1790-T0W8X	8 relay output expansion block
1790-T8A0X	120VAC, 8 input expansion block
1790-T0A8X	120VAC, 8 output expansion block

Overview

CompactBlock LDX I/O for PROFIBUS DP blocks are compatible with any PROFIBUS DP scanner.

Set node addresses on the blocks using rotary switches located on the base block.

Benefits

- Wide breadth of I/O types that can handle diverse commercial applications
- Expands up to 4 digital blocks for flexibility of node size (16-64 points)
- Base blocks have a built-in PROFIBUS adapter
 - Digital base blocks (24Vdc, 120Vac and relay) can support up to 3 digital expansion blocks
 - Analog base blocks (current and voltage) can support up to 2 digital expansion blocks
 - RTD and Thermocouple base blocks **do not** support expansion blocks
- Universal sink/source inputs reduces the number of components to stock and allows flexibility of input types

- Compatible with a broad range of sensors:
 - NEMA/IEC Type 3 compliance for DC blocks
- Very compact, can fit into confined areas (118mm x 52mm x 42mm)
- Use GSD files to connect and configure
- Installation and configuration costs are minimized
- PROFIBUS DP conformance tested means high level of interoperability with other PROFIBUS products
- RTD and thermocouple blocks support a wide range of sensors and have on-board scaling
- Mounts horizontally or vertically on DIN rail
- UL/cUL Listed, CE certified

Typical Configuration

This illustration shows how CompactBlock LDX I/O fits into a typical PROFIBUS system.

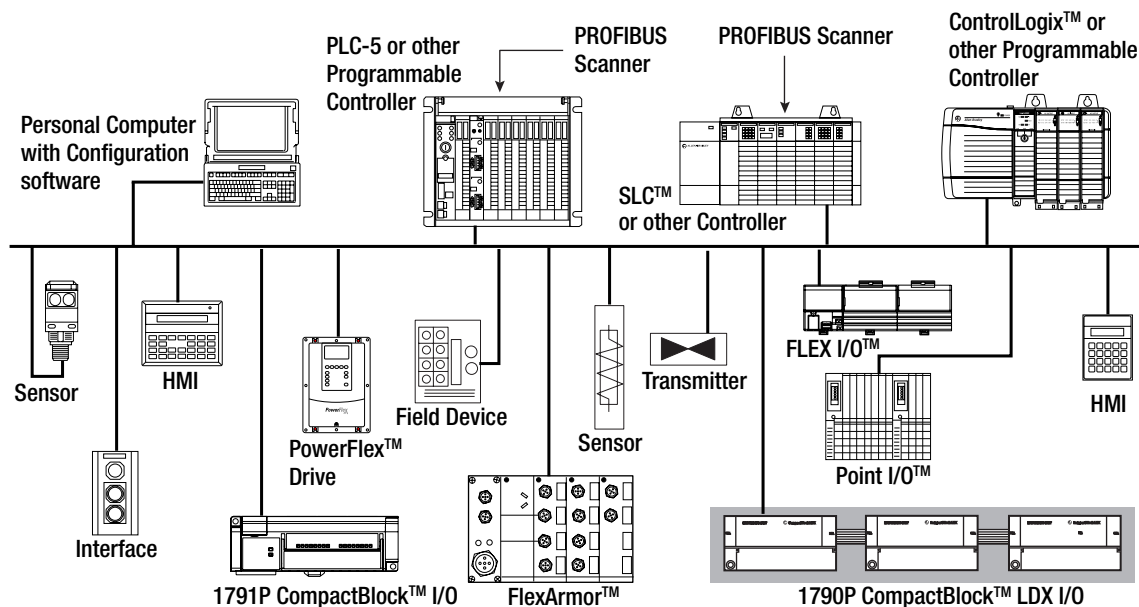

System Compatibility

CompactBlock LDX I/O blocks are compatible with any PROFIBUS DP scanner.

CompactBlock LDX I/O on PROFIBUS DP

Optimized for high speed and inexpensive installation, PROFIBUS DP (decentralized periphery) is designed especially for communication between programmable controllers (PLCs) and distributed I/O at the device level. Data exchange is mainly cyclic with field devices such as I/O, valves, drives and measuring transducers. The primary controller (master) reads the input information from the field devices (slaves) and sends the output information back to the slaves.

The communication functions required for this are highlighted in the following table and are defined by the PROFIBUS standard.

Basic DP Functions

Bus Access	<ul style="list-style-type: none"> • Token passing procedure between masters and master-slave procedure between master and slaves • Mono-master or multi-master system possible • Master and slave devices, maximum 126 stations on one bus
Communication	<ul style="list-style-type: none"> • Peer-to-peer (user data communication) or multicast (control commands) • Cyclic master-slave user data communication
Operating States	<ul style="list-style-type: none"> • Operate - cyclic transmission of input and output data • Clear - inputs are read, outputs remain in secure state • Stop - diagnostics and parameterization, no user data transmission
Synchronization	<ul style="list-style-type: none"> • Control commands allow the synchronization of inputs and outputs • Sync mode - outputs are synchronized • Freeze mode - Inputs are synchronized
Functions	<ul style="list-style-type: none"> • Cyclic user data transfer between DP master and slave • Dynamic activation or deactivation of individual slaves • Checking the configuration of the slaves • Powerful diagnostic functions, 3 hierarchical levels of diagnostic messages • Synchronization of input and/or outputs • Address assignment for slaves optionally possible via the bus • Maximum of 244 bytes input and output data possible for each slave
Protective Functions	<ul style="list-style-type: none"> • All messages are transmitted at a hamming distance of HD=4 • Watchdog control of DP slave detects failure of the assigned master • Access protection for inputs/outputs of slaves • Monitoring of user data communication with adjustable monitoring timer in the master
Device Types	<ul style="list-style-type: none"> • DP master Class 2 (DPM2), e.g. engineering or diagnostics tool • DP master Class 1 (DPM1), e.g. central programmable controllers such as PLC, SLC, PC • DP slave e.g. devices with binary or analog inputs/outputs, drives, valves

Data communication is monitored on both the master and slave sides.

Speed

PROFIBUS DP requires about 1 msec at 12 Mbit/sec to transmit 512 bits of input data and 512 bits of output data to 32 stations.

Diagnostics

Diagnostic messages are transmitted over the network and collected at the master and are classified into three types:

- **Station-related** - status of the device (for example, low voltage or over temperature, depending on the device).
- **Module-related** - indicates if any of the connected I/O modules report errors. More detailed information of the error can be found by evaluating the channel-related diagnostic message.
- **Channel-related** - provides information on channel errors of the I/O modules and expands on the module-related diagnostics.

System Configuration and Devices Types

PROFIBUS DP consists of mono-master or multi-master systems. This allows flexibility during system configuration.

A maximum of 126 master or slave devices can connect to one network. System configuration specifications define:

- the number of stations
- assignment of station addresses to the I/O addresses
- data consistency of the I/O data
- format of the diagnostic messages
- bus parameters

Each PROFIBUS DP system consists of three different types of devices:

DP Master Class 1 (DPM1) - this is a central controller which cyclically exchanges information with the distributed stations (slaves) in a defined message cycle. This device is typically the PLC.

DP Master Class 2 (DPM2) - this is a configuration or operating device used for commissioning, maintenance or diagnostics. It also evaluates measured values and parameters and requests device status. This device is typically the scanner or adapter.

Slave - this is a peripheral I/O field device such as an HMI, drive, relay or sensor. Depending on the type, the slave device collects input information and sends output information to the peripherals. The maximum amount of input and output information is 244 bytes of input and 244 bytes of output.

Mono-master systems contain only one PLC on the network. The field devices are decentrally linked to the PLC via the transmission medium. These systems offer the shortest communication time.

Multi-master systems contain several PLCs on one network. This system can be configured either with independent subsystems each consisting of one DPM1 master and its assigned slaves, or with additional configuration and diagnostic devices. Input and output information of the slaves can be read by all masters, however, only one master can write-access the outputs.

Operating Modes and System Status

Sync/Freeze

In addition to the cyclic data exchange which is executed automatically by the master, the master can send control commands to a single slave, a group of slaves or all slaves simultaneously. These control commands are transmitted as multicast commands and allow use of sync and freeze modes for event-controlled synchronization of the slaves.

The slave begins **sync mode** when it receives a sync command from the assigned master. The output channels of all I/O modules are then frozen in their current state. During subsequent user data transmission, the output data is stored in the scanner, but the output states remain unchanged. The stored output data is not sent to the outputs until the sync command is received. Sync mode is concluded with the unsync command.

Similarly, a freeze control command causes the adapter to assume **freeze mode**. In this operating mode, the states of the input channels of all I/O modules are frozen at the current value. Input data is not updated again until the master sends the next freeze command. Freeze is concluded with the unfreeze command.

General system behavior is determined by the operating status of the master. The three main states are:

- **Stop** - no data transmission occurs between the master and the slaves
- **Operate** - the master is in the data transfer phase. In cyclic data communication, inputs of the slaves are read and output information is written to the slaves.
- **Clear** - the master reads the information of the slaves and sets the outputs to an idle state.

The system reaction to an error during the data transfer phase of the master (such as slave failure) is determined by the **auto clear** configuration parameter. If this parameter is set to true, the master switches the outputs of all assigned slaves to fail-safe state as soon as a slave is no longer ready for user data transmission. The master then changes to the **clear** state. If this parameter is false, the master remains in operate state even when a fault occurs with the user specifying the proper system reaction.

Cyclic Data Transmission

Data transmission between the master and its slaves is executed automatically by the master in a defined, recurring order. When configuring the network, the user defines the assignment of a slave to the master. At this time, the user also defines which slaves are to be included or excluded from the cyclic user data communication.

This transmission of data is divided into three categories:

- parameterization
- configuration
- data transfer

Before a slave enters the data transfer phase, it is checked in the parameterization and configuration phases to determine whether the planned configuration matches the actual device configuration.

During this check, the following must agree:

- device type
- format and length information
- number of inputs and outputs

These checks offer reliable protection against parameterization errors. In addition to the user data transfer which is executed automatically by the master, new parameterization data can be sent to the slaves at the user's request.

Configuration and GSD File Requirements

You can configure CompactBlock LDX I/O blocks using GSD files and any PROFIBUS DP configuration package.

The GSD files are available on-line at: www.ab.com/networks/gsd/

Status Indicators

Each CompactBlock I/O block has indicators to provide a diagnostic readout.

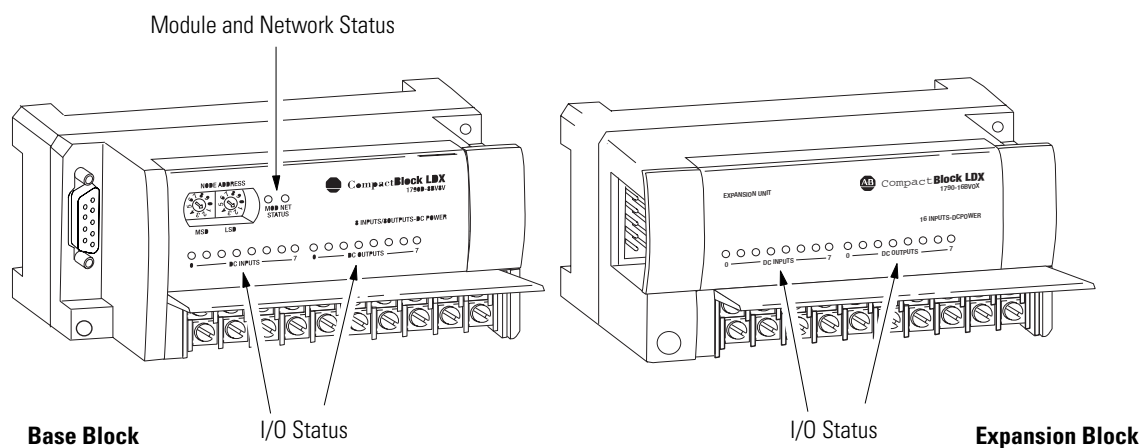

Module/Network Status Indicators - All Base Blocks

Mod/Net Status Indicator		
LED Indicator:	Status:	Description:
Module Status	Solid Red	Unrecoverable fault in base block
	Flashing Red	Recoverable fault
	Solid Green	Normal operation - OK
	Flashing Green	Standby
	Off	No power
LED Indicator:	Status:	Description:
Network Status	Solid Red	Unrecoverable communication fault
	Flashing Red	Recoverable communication fault
	Solid Green	Communication path complete - OK
	Flashing Green	Communication path incomplete
	Off	Device not online or not powered

I/O Status Indicators - Digital Base and Expansion Blocks

I/O Status Indicators			
Function:	LED Color:	Module Illumination:	Condition:
Outputs	Each output: Green	None Green	Output not energized Output energized
Inputs	Each Input: Green	None Green	No valid input Valid input

I/O Status Indicators - Analog Base Block

1790P-TN4C0 - Analog Current Input Block	
Status:	Description:
Flashing Green/Red	Power up
Off	Off line
Red	On line and no field power
Red	DeviceNet connection and no field power
Flashing Red ¹	Field power and open wire (4-20mA range only) ²
Green	Field power and valid input
Green	Input over range
Flashing Red ¹	Input under range <3mA (4-20ma range only) ²
Flashing Red	Recoverable fault

¹ Green for 0-20mA range.

² Can be determined from the data table.

I/O Status Indicators - Analog Base Block

1790P-TN0C2 Analog Current Output Block	
Status:	Description:
Flashing Green/Red	Power up
Off	Off line
Off	On line and no field power
Green	DeviceNet connection and no field power
Green	Field power and open wire
Green	Field power and valid output
Flashing Red	Field power and output out of range
Flashing Green	Output idle
Flashing Red	Recoverable fault

I/O Status Indicators - RTD and Thermocouple Base Blocks

1790P-T4R0, -T4T0	
Status:	Description:
Flashing Green/Red	Power up
Off	Off line
Red	On line and no field power
Red	DeviceNet connection and no field power
Flashing Red	Field power and open wire
Green	Field power and valid input
Flashing Red	Input over range
Flashing Red	Input under range
Flashing Red	Recoverable fault

Power Supply Requirements

An external power supply for the PROFIBUS network is required for CompactBlock I/O base blocks as shown in the figure below. Inputs and outputs are powered by an external 24V dc source which is independent of the network.

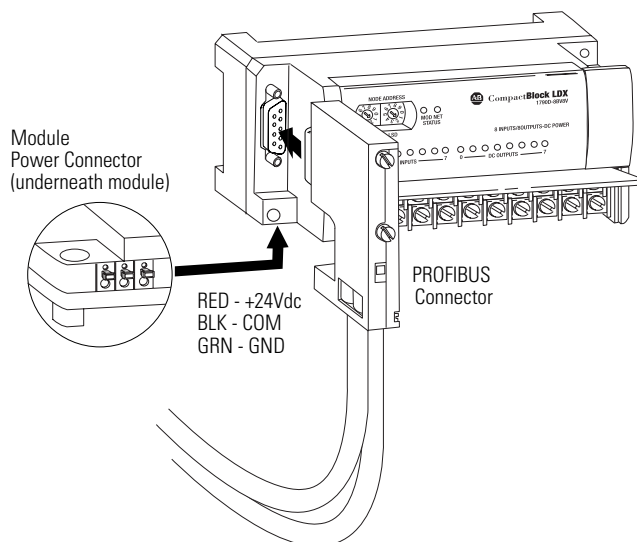

Mounting

You can mount the CompactBlock I/O base and expansion blocks directly to a panel or on a DIN rail.

The following illustration shows the base and expansion blocks mounting dimensions.

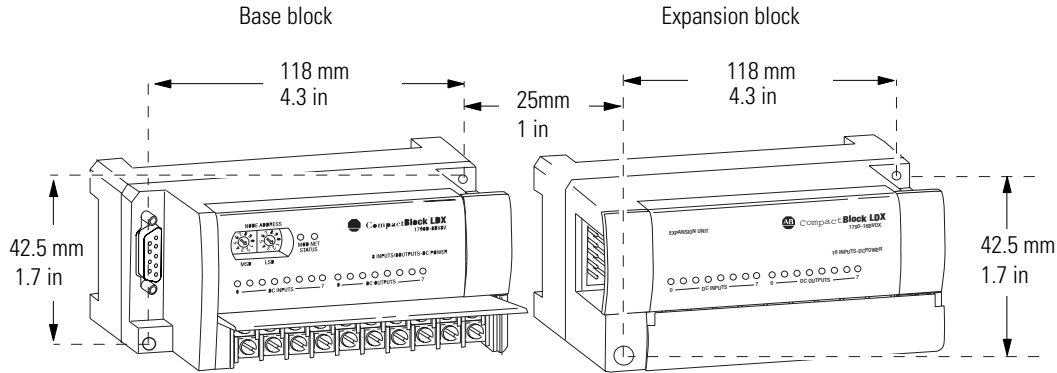

Remember to consider the length of the expansion ribbon cable when installing a base block with an expansion block. The expansion block must be close enough for the expansion cable to reach from the base block to the expansion block.

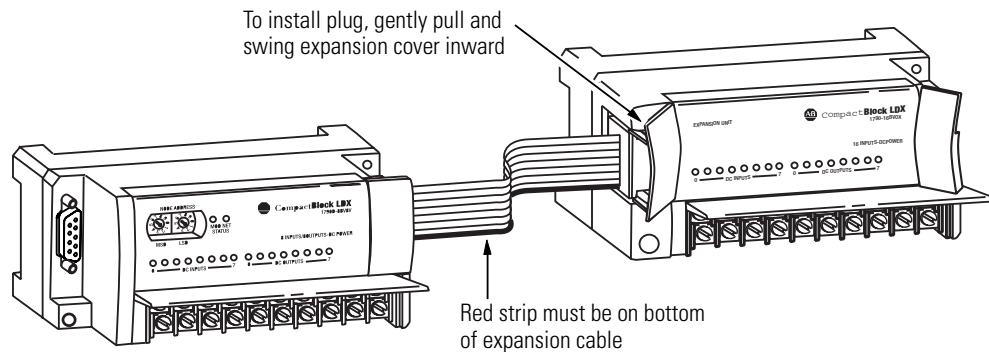

Beginning with the base block, you can mount the blocks either horizontally or vertically as shown below:

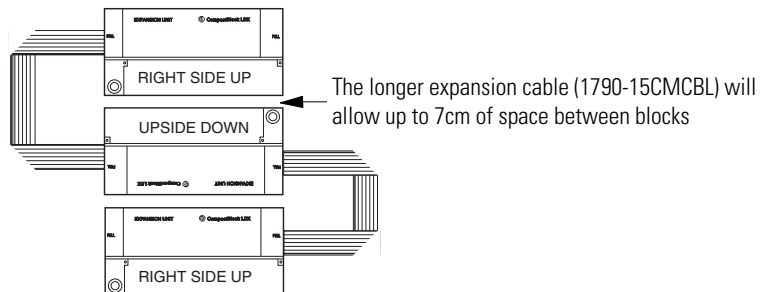
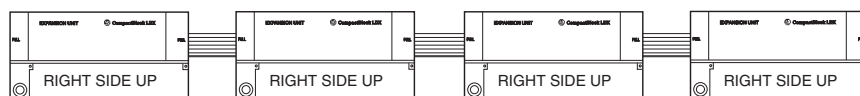

Possible Configurations

Digital and analog base blocks support up to 3 or 2 expansion blocks respectively. However, RTD and Thermocouple base blocks do not support expansion blocks.

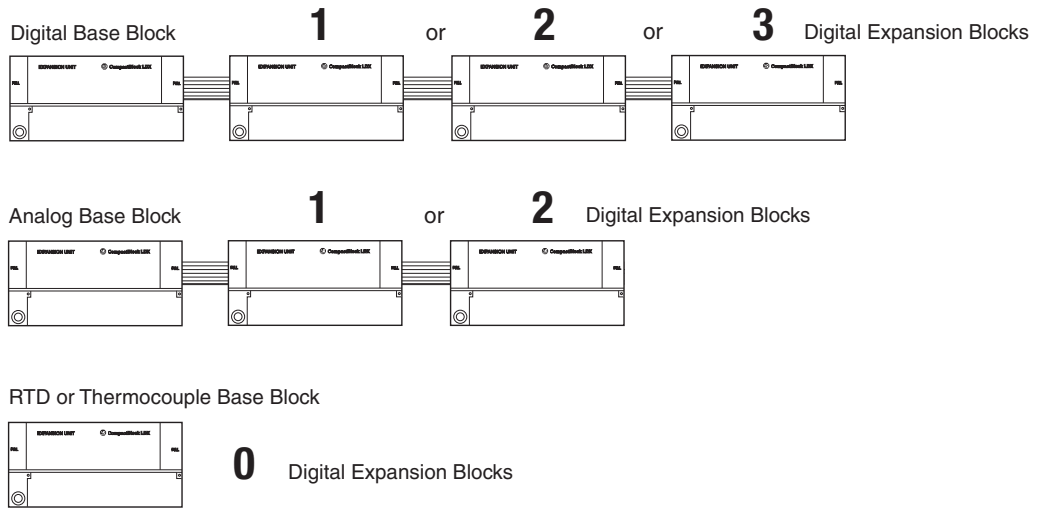

CompactBlock LDX I/O Accessory Cables

CompactBlock LDX I/O Accessories

Description	Part Number
7cm LDX I/O replacement ribbon cable (included with expansion module)	1790-7CMCBL
15cm optional LDX I/O ribbon cable (required for vertical mounting)	1790-15CMCBL

PROFIBUS DP Terminal Connector

The required PROFIBUS female 9-pin D-sub connector is not supplied with the base block - you must purchase it separately.

The following table shows proper wiring for the female 9-pin D-sub connector.

Pin Number:	Name:	Description:
1	shield	Shield, Protective Ground
2	M24V	Minus 24V Output Voltage
3	RxD/TxD-P	Receive/Transmit-Data-P
4	CNTR-P	Control-p
5	DGND	Data Ground
6	VP	Voltage-Plus
7	P24V	Plus 24V Output Voltage
8	RxD/TxD-N	Receive/Transmit-Data-N
9	CNTR-N	Control-N

Detailed Block Information

The remainder of this publication describes detailed information for each CompactBlock LDX I/O block, such as:

- schematic diagrams
- word/bit descriptions
- connection wiring diagrams
- specifications

Refer to the table below to find information about a specific block.

For information about:	See page:
PROFIBUS DP Base and Expansion Terminal Blocks	
General Specifications	14
24VDC, 8 universal input/8 sourcing output base and expansion (1790P-T8BV8B and 1790-T8BV8BX)	15
24VDC, 8 universal input/8 sinking output base and expansion (1790P-T8BV8V and 1790-T8BV8VX)	16
6 relay output base (1790P-T0W6)	17
8 relay output expansion (1790-T0W8X)	18
4 channel analog current input base (1790P-TN4C0)	19
2 channel analog current output base (1790P-TN0C2)	20
4 channel input RTD base (1790P-T4R0)	21
4 channel input Thermocouple base (1790P-T4T0)	22
24VDC, 16 sinking/sourcing input expansion (1790-T16BV0X)	23
24VDC, 16 sourcing output expansion (1790-T0B16X)	24
24VDC, 16 sinking output expansion (1790-T0V16X)	25
120VAC, 8 input expansion (1790-T8A0X)	26
120VAC, 6 output expansion (1790-T0A8X)	27

Related Publications

Refer to the following list of publications for more information about CompactBlock LDX I/O for PROFIBUS DP blocks.

Title:	Publication Number:
Digital Expansion D-shell Block CompactBlock LDX I/O Installation Instructions	1790-IN003
Digital Expansion Terminal Block CompactBlock LDX I/O Installation Instructions	1790-IN005
PROFIBUS DP Digital Base Terminal Block Installation Instructions	1790-IN009
PROFIBUS DP Analog, RTD and Thermocouple Base Terminal Block Installation Instructions	1790-IN010
CompactBlock LDX I/O Analog Modules User Manual	1790-UM001
CompactBlock LDX I/O TRD Modules User Manual	1790-UM002
CompactBlock LDX I/O Thermocouple Modules User Manual	1790-UM003
CompactBlock LDX I/O Product Profile	1790-PP002

Notes:

PROFIBUS Base and Expansion Terminal Blocks

General Specifications

The following table contains specifications that are common to all of the PROFIBUS base and expansion blocks in this section. Individual block connection sizes, word/bit definitions, schematics, wiring diagrams and specifications are detailed after this table.

Environmental Specifications	
Operating Temperature	0 to 55°C (32 to 131°F) IEC 60068-2-1 (Test Ad, Operating Cold), IEC 60068-2-2 (Test Bd, Operating Dry Heat), IEC 60068-2-14 (Test Nb, Operating Thermal Shock)
Storage Temperature	-40 to 85°C (-40 to 185°F) IEC 60068-2-1 (Test Ab, Un-packaged Non-operating Cold), IEC 60068-2-2 (Test Bb, Un-packaged Non-operating Dry Heat), IEC 60068-2-14 (Test Na, Un-packaged Non-operating Thermal Shock)
Relative Humidity	5-90% non-condensing IEC 60068-2-30 (Test Db, Un-packaged Non-operating)
Operating Altitude	2000m
Vibration	2g @ 10-500Hz IEC60068-2-6 (Test Fc, Operating)
Shock: Operating Non-operating	10g 30g IEC60068-2-27 Test Ea, (Unpackaged Shock)
Emissions	Group 1, Class A CISPR 11
ESD Immunity	8kV air discharges IEC 61000-4-2
Radiated RF Immunity	10V/m with 1kHz sine-wave 80%AM from 80MHz to 1000MHz 10V/m with 200Hz 50% Pulse 100%AM @ 900MHz IEC 61000-4-3
EFT/B Immunity	±1kV @ 5kHz on power ports ±2kV @ 5kHz on signal ports ±2kV @ 5kHz on communications ports IEC 61000-4-4
Surge Transient Immunity	±1kV line-line(DM) and ±2kV line-earth(CM) on power ports ±1kV line-line(DM) and ±2kV line-earth(CM) on signal ports ±2kV line-earth(CM) on shielded ports IEC 61000-4-5
Conducted RF Immunity	10Vrms with 1kHz sine-wave 80%AM from 150kHz to 80MHz IEC 61000-4-6
Enclosure Type Rating	None (open style)
Mounting	DIN rail or screw
Dimensions	52x118.5x42mm (2.03x4.62x1.64in)
Weight	0.3lb (0.1kg)

PROFIBUS DP Specifications	
Network Protocol	PROFIBUS-DP (EN50170) <ul style="list-style-type: none"> • Communication of the slave with a Class 1 master • Communication of the slave with a Class 2 master
Redundancy	Not supported
Repeater Control Signal	RS485 signal
Implementation Type	DPC31
Freeze Mode	Supported
Sync Mode	Supported
Auto Baud Rate	Supported
Fail Safe Mode	Supported ¹
Station Type	Slave
FMS Support	Not supported
Indicators	1 red/green module status 1 red/green network status
Number of nodes	100 maximum - rotary switch type node address setting (0-99)
Network Length/ Communication rate	9.6Kbps @ 1000m (3280ft) 19.2Kbps @ 1000m (3280ft) 45.45Kbps @ 1000m(3280ft) 93.75Kbps @ 1000m (3280ft) 187.5Kbps @ 1000m (3280ft) 500Kbps @ 400m (1312ft) 1.5mbps @ 200m (656ft) 3mbps @ 100m (328ft) 6mbps @ 100m (328ft) 12mbps @ 100m (328ft)
Isolation	Type test 1250Vac rms for 60 seconds between field power and PROFIBUS (I/O to logic)
General Specifications	
Wiring Category	2 ²
Product Certifications (when product is marked)	c-UL-us UL Listed for Class I, Division 2 Group A,B,C,D Hazardous Locations, certified for U.S. and Canada FM FM Approved Equipment CE ³ European Union 89/336/EEC EMC Directive, compliant with: EN 61000-6-4; Industrial Emissions EN 50082-2; Industrial Immunity EN61326; Meas./Control/Lab., Industrial Requirements EN 61000-6-2; Industrial Immunity European Union 73/23/EEC LVD Directive, compliant with: EN 61131-2; Programmable Controllers C-Tick ³ Australian Radiocommunications Act, compliant with: AS/NZS 2064; Industrial Emissions

¹ Dependant upon the scanner module being used. For example, the SST Scanner (cat. no. SST-PFB-SLC) does not fully support Fail Safe mode as it only resets outputs to 0. You cannot define behavior such as Hold Last State or Fault Value with the SST Scanner.

² Refer to publication 1770-4.1, *Programmable Controller Wiring and Grounding Guidelines*.

³ See the Product Certification link at www.ab.com for Declarations of Conformity, Certificates and other certification details.

24VDC 8 Universal Input/8 Sourcing Output Base and Expansion Blocks - 1790P-T8BV8B and 1790-T8BV8BX

Simplified Schematic

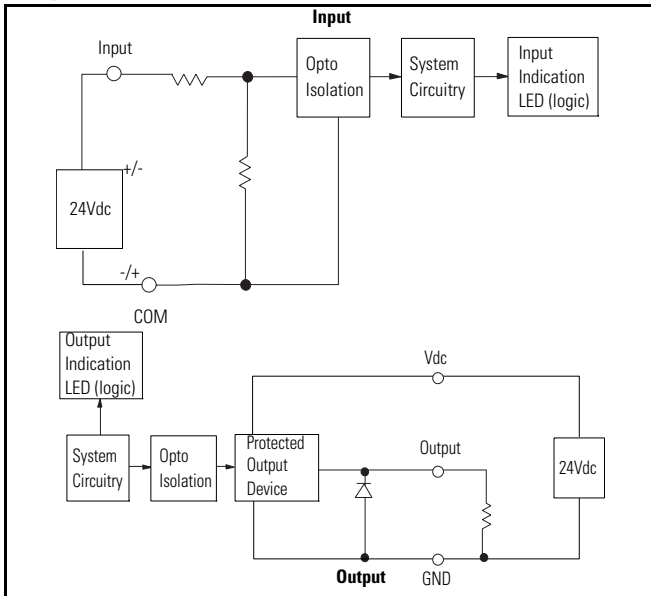

Wiring Diagram for Terminal Block

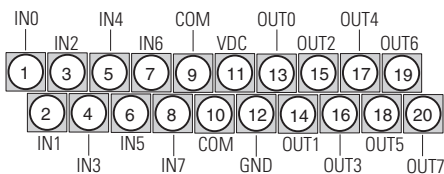

- **Sinking inputs** - wire COM (pin 9) to Field Power (-) GND
- **Sourcing inputs** - wire COM (pin 9) to Field Power (+) 24Vdc
- **Note:** both COM (pins 9 and 10) are internally connected.
- **Sourcing outputs** - wire VDC (pin 11) to Field Power (+) 24Vdc, wire GND (pin 12) to Field Power (-) GND

I/O Memory Mapping - Input and Output Data Files

Byte	Bit Position							
	7	6	5	4	3	2	1	0
0	IN7	IN6	IN5	IN4	IN3	IN2	IN1	IN0

Byte	Bit Position							
	7	6	5	4	3	2	1	0
0	OUT7	OUT6	OUT5	OUT4	OUT3	OUT2	OUT1	OUT0

Block Specifications

1790P-T8BV8B, 1790-T8BV8BX	
INPUT SPECIFICATIONS	
Inputs per block	8 points non-isolated, sinking or sourcing
On-state voltage	9.6V dc minimum 24V dc nominal 28.8V dc maximum
On-state current	8mA maximum per point @ 28.8V dc
Off-state voltage	5V dc maximum
Nominal input impedance	4.8KΩ
Indicators	8 green status
Common type	8 points/8COM (non-polarity)
OUTPUT SPECIFICATIONS	
Outputs per block	8 points non-isolated, sourcing
On-state voltage	10V dc minimum 24V dc nominal 28.8V dc maximum
On-state voltage drop	0.5V dc maximum
On-state current	1mA minimum per channel
Off-state leakage	0.5mA maximum
Output signal delay	Off to On: 0.5ms maximum On to Off: 1.0ms maximum
Indicators	8 green status
Output current rating	Maximum 0.5A per output 4.0A maximum per common
Common type	8 points/2COM
General Specifications	
PROFIBUS Power - base block	Supply voltage - 24V dc nominal Voltage range - 19.2-28.8V dc Power dissipation - 2W maximum @ 28.8V dc
Field Power	Supply voltage - 24V dc nominal Voltage range - 10-28.8V dc Power dissipation - 6mA @ 28.8V dc per point
Isolation	I/O to logic: photocoupler isolation Isolation voltage: 1250V ac rms PROFIBUS to logic: non-isolated PROFIBUS power: non-isolated
Wiring	Terminal block (M3.0) - screw torque: 7 inch-pounds maximum (use copper or copper-clad aluminum conductors)

24VDC 8 Universal Input/8 Sinking Output Base and Expansion Blocks - 1790P-T8BV8V and 1790-T8BV8VX

Simplified Schematic

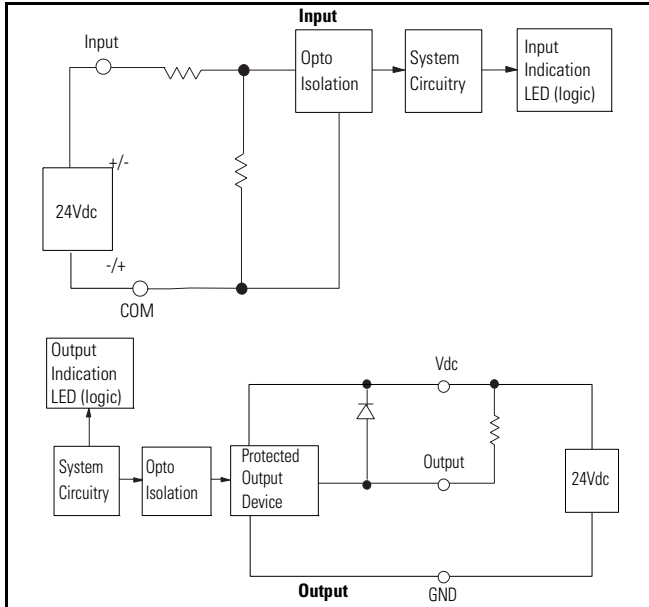

Wiring Diagram for Terminal Block

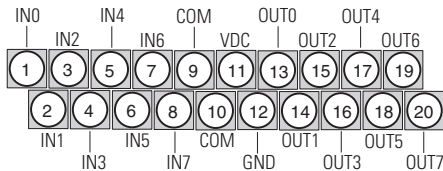

- **Sinking inputs** - wire COM (pin 9) to Field Power (-) GND
- **Sourcing inputs** - wire COM (pin 9) to Field Power (+) 24V dc
- **Note:** both COM (pins 9 and 10) are internally connected.
- **Sinking outputs** - wire VDC (pin 11) to Field Power (+) 24Vdc, wire GND (pin 12) to Field Power (-) GND

I/O Memory Mapping - Input and Output Data Files

Byte	Bit Position							
	7	6	5	4	3	2	1	0
0	IN7	IN6	IN5	IN4	IN3	IN2	IN1	IN0

Byte	Bit Position							
	7	6	5	4	3	2	1	0
0	OUT7	OUT6	OUT5	OUT4	OUT3	OUT2	OUT1	OUT0

Block Specifications

1790P-T8BV8V and 1790-T8BV8VX	
INPUT SPECIFICATIONS	
Inputs per block	8 points non-isolated, sinking or sourcing
On-state voltage	9.6V dc minimum 24V dc nominal 28.8V dc maximum
On-state current	8mA maximum per point @ 28.8V dc
Off-state voltage	5V dc maximum
Nominal input impedance	4.8KΩ
Indicators	8 green status
Common type	8 points/2COM (non-polarity)
OUTPUT SPECIFICATIONS	
Outputs per block	8 points non-isolated, sinking
On-state voltage	10V dc minimum 24V dc nominal 28.8V dc maximum
On-state voltage drop	0.5V dc maximum
On-state current	1mA minimum per channel
Off-state leakage	0.5mA maximum
Output signal delay	Off to On: 0.5ms maximum On to Off: 1.0ms maximum
Indicators	8 green status
Output current rating	Maximum 0.5A per output 4.0A maximum per common
Common type	8 points/2COM
General Specifications	
PROFIBUS Power - base block	Supply voltage - 24V dc nominal Voltage range - 19.2-28.8V dc Power dissipation - 2W maximum @ 28.8V dc
Field Power	Supply voltage - 24V dc nominal Voltage range - 10-28.8V dc Power dissipation - 6mA @ 28.8V dc per point
Isolation	I/O to logic: photocoupler isolation Isolation voltage: 1250V ac rms PROFIBUS to logic: non-isolated PROFIBUS power: non-isolated
Wiring	Terminal block (M3.0) - screw torque: 7 inch-pounds maximum (use copper or copper-clad aluminum conductors)

6 Relay Output Base Block - 1790P-T0W6

Simplified Schematic

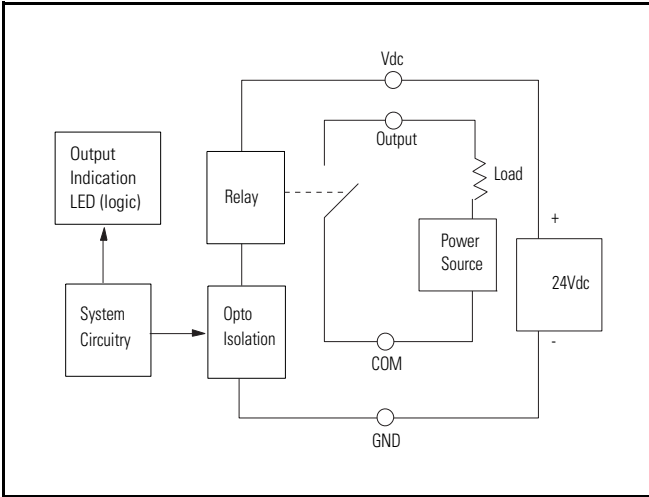

Wiring Diagram for Terminal Block

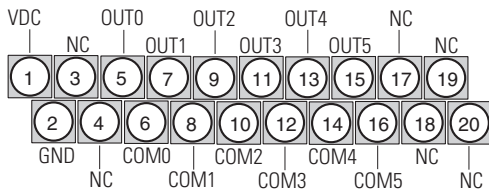

- Wire VDC (pin 1) to Field Power (+) 24Vdc
Wire GND (pin 2) to Field Power (-) GND

I/O Memory Mapping - Output Data File

Byte	Bit Position							
	7	6	5	4	3	2	1	0
0	Not Used		OUT5	OUT4	OUT3	OUT2	OUT1	OUT0

Block Specifications

1790P-T0W6	
Relay type	Form A, normally open Single pole, single throw
Output voltage range (load dependent)	5-24V dc @ 2.0A resistive 30V ac @ 2.0A resistive 125V ac @ 2.0A resistive 250V ac @ 2.0A resistive
Minimum load	100µA, 100mV dc per input
Maximum on-state voltage drop	0.5V @ 2.0A, resistive load, 24V dc
Initial Contact Resistance	30m ohm
Expected contact life	300K cycles resistive 100K cycles inductive
Maximum off-state leakage	1.5mA maximum
Output delay time	10ms maximum on to off or off to on
Indicators	6 green status
Common type	1 point/1COM
General Specifications	
PROFIBUS Power	Supply voltage - 24V dc nominal Voltage range - 19.2-28.8V dc Power dissipation - 2W maximum @ 28.8V dc
Field Power	Supply voltage - 24V dc nominal Voltage range - 19.2-28.8V dc Power dissipation - 1.7W @ 28.8V dc
Isolation	I/O to logic: photocoupler isolation Isolation voltage: 1250V ac rms
Wiring	Terminal block (M3.0) - screw torque: 7 inch-pounds maximum (use copper or copper-clad aluminum conductors)

8 Relay Output Expansion Block - 1790-TOW8X

Simplified Schematic

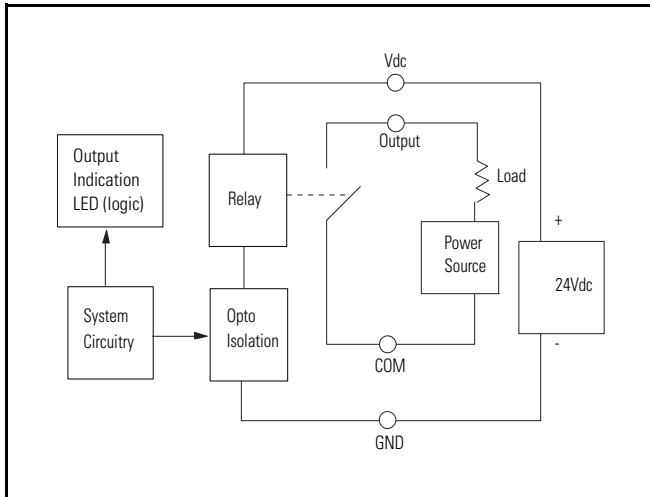

Wiring Diagram for Terminal Block

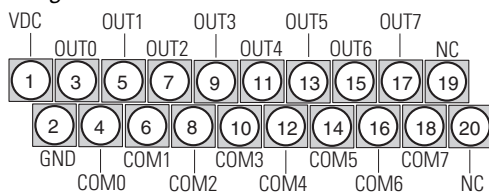

- Wire VDC (pin 1) to Field Power (+) 24Vdc
Wire GND (pin 2) to Field Power (-) GND

I/O Memory Mapping - Output Data File

Byte	Bit Position							
	7	6	5	4	3	2	1	0
0	OUT7	OUT6	OUT5	OUT4	OUT3	OUT2	OUT1	OUT0

Block Specifications

1790-TOW8X	
Relay type	Form A, normally open Single pole, single throw
Output voltage range (load dependent)	5-24V dc @ 2.0A resistive 30V ac @ 2.0A resistive 125V ac @ 2.0A resistive 250V ac @ 2.0A resistive
Output current rating (at rated power)	2.0A @ 5-24V dc resistive 2.0A @ 30V dc resistive
Minimum load	100µA, 100mV dc per input
Maximum on-state voltage drop	0.5V @ 2.0A, resistive load, 24V dc
Initial Contact Resistance	30m ohm
Expected contact life	300K cycles resistive 100K cycles inductive
Maximum off-state leakage	1.5mA maximum
Output delay time	10ms maximum on to off or off to on
Indicators	8 green status
Common type	1 point/1COM
General Specifications	
Field Power	Supply voltage - 24V dc nominal Voltage range - 19.2-28.8V dc Power dissipation - 2.3W @ 28.8V dc
Isolation	I/O to logic: photocoupler isolation Isolation voltage: 1250V ac rms
Wiring	Terminal block (M3.0) - screw torque: 7 inch-pounds maximum (use copper or copper-clad aluminum conductors)

4 Channel Analog Current Input Base Block - 1790P-TN4C0

Simplified Schematic

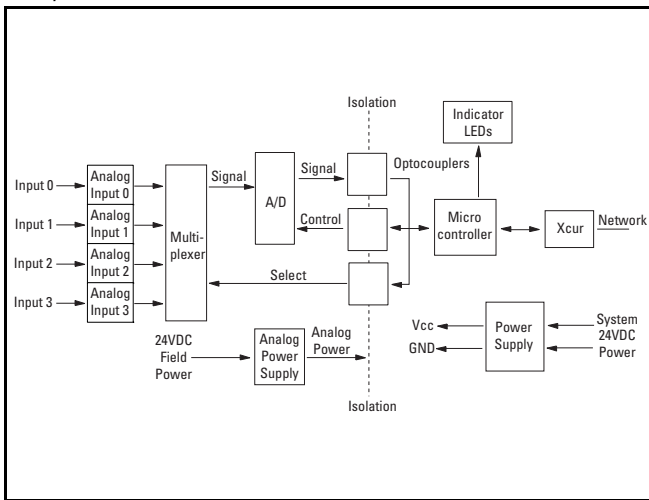

Wiring Diagram for Terminal Block

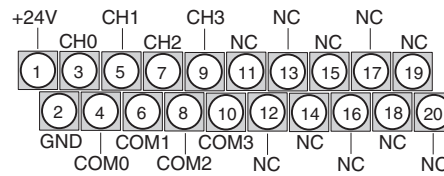

- Wire pin 1 to Field Power (+) 24Vdc
- Wire pin 2 to Field Power (-) GND

Input Data File

Word	Bit Position															
	15	14	13	12	11	10	9	8	7	6	5	4	3	2	1	0
0	Not Used				Analog Input Data Channel 0											
1	Not Used				Analog Input Data Channel 1											
2	Not Used				Analog Input Data Channel 2											
3	Not Used				Analog Input Data Channel 3											
4	Not Used												S	S	S	S

Word/Bit Descriptions

Word	Decimal Bit	Description
Read Word 0	Bits 00-11	Channel 0 input data
	Bits 12-15	Not used: Set to 0
Read Word 1	Bits 00-11	Channel 1 input data
	Bits 12-15	Not used: Set to 0
Read Word 2	Bits 00-11	Channel 2 input data
	Bits 12-15	Not used: Set to 0
Read Word 3	Bits 00-11	Channel 3 input data
	Bits 12-15	Not used: Set to 0
Read Word 4	Bits 00-03	Status bits for individual channels - Bit 00 corresponds to input channel 0, bit 01 corresponds to input channel 1 and so on. When set (1) indicates: <ul style="list-style-type: none"> • No field power • Open wire (4-20mA current input only) • Under range (4-20mA current input only) • Recoverable module fault (whole channel to be set) • Unrecoverable module fault (whole channel to be set)
	Bits 04-15	Not used: Set to 0

Block Specifications

1790P-TN4C0	
Inputs per module	4 channel single-ended, non-isolated
Input Current (software configurable)	4-20mA (default) 0-20mA
Resolution	12 bits-unipolar 1/4096 maximum 3.90µA/bit (4-20mA) 4.88µA/bit (0-20mA)
Converted Data	Binary data 0000 to Off (max scale)
Conversion Time	10ms/channel
Overall accuracy	0.2% Full scale @0°-55°C
Calibration	None required
Input Impedance	249Ω
Insulation Resistance	20MΩ minimum @ 250V dc (between insulated circuits)
General Specifications	
PROFIBUS Power	Supply voltage - 24V dc nominal Voltage range - 19.2-28.8V dc Power dissipation - 2W maximum @ 28.8V dc
Field Power	Supply Voltage - 24Vdc nominal Voltage Range - 21.6-26.4V dc (±10%) Power Dissipation - 1.5W maximum @26.4V dc
Isolation	I/O to logic: photocoupler isolation Isolation voltage: Type Test 1250V ac rms for 60 seconds PROFIBUS to logic: non-isolated Field power: non-isolated
Indicators	4 red/green I/O status
Wiring	Terminal block (M3.0) - screw torque: 7 inch-pounds maximum (use copper or copper-clad aluminum conductors)

IMPORTANT: This analog base module can accommodate a **maximum** of two discrete expansion modules.

2 Channel Analog Current Output Base Block - 1790P-TN0C2

Simplified Schematic

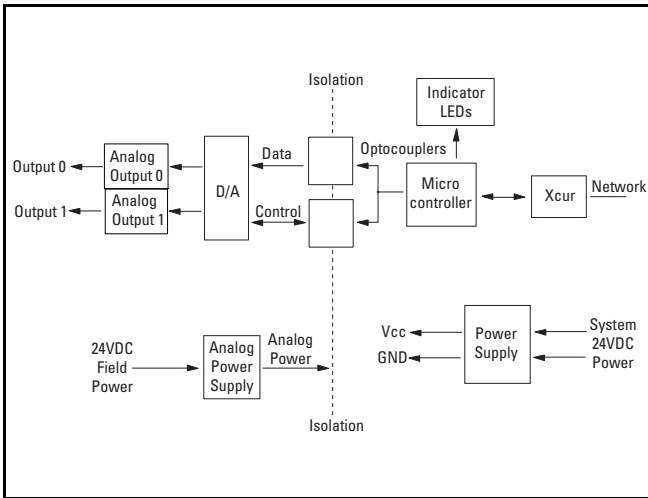

Word/Bit Descriptions

Word	Decimal Bit	Description
Write Word 0	Bits 00-11	Channel 0 output data
	Bits 12-15	Not used: Set to 0
Write Word 1	Bits 00-11	Channel 1 output data
	Bits 12-15	Not used: Set to 0

Output Data File

Word	Bit Position															
	15	14	13	12	11	10	9	8	7	6	5	4	3	2	1	0
0	Not Used				Analog Output Data Channel 0											
1	Not Used				Analog Output Data Channel 1											

Wiring Diagram for Terminal Block

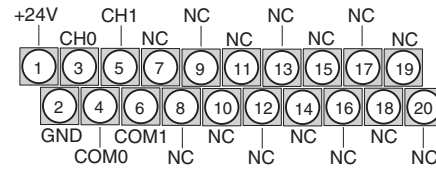

- Wire pin 1 to Field Power (+) 24Vdc
- Wire pin 2 to Field Power (-) GND

Block Specifications

1790P-TN0C2	
Outputs per module	2 channel single-ended, non-isolated
Output Current	0-20mA
Resolution	12 bits 1/4096 maximum 4.88µA/bit
Converted Data	Binary data 0000 to 0fff (max scale)
Conversion Time	2ms/channel
Overall accuracy	0.2% Full scale @0°-55°C
Calibration	None required
Allowable external output load resistance	600Ω maximum
Insulation Resistance	20MΩ minimum @ 250V dc (between insulated circuits)

General Specifications	
PROFIBUS Power	Supply voltage - 24V dc nominal Voltage range - 19.2-28.8V dc Power dissipation - 2W maximum @ 28.8V dc
Field Power	Supply Voltage - 24Vdc nominal Voltage Range - 21.6-26.4V dc (±10%) Power Dissipation - 1.5W maximum @26.4V dc
Isolation	I/O to logic: photocoupler isolation Isolation voltage: Type Test 1250V ac rms for 60 seconds PROFIBUS to logic: non-isolated Field power: non-isolated
Indicators	2 red/green I/O status
Wiring	Terminal block (M3.0) - screw torque: 7 inch-pounds maximum (use copper or copper-clad aluminum conductors)

IMPORTANT: This analog base module can accommodate a **maximum** of two discrete expansion modules.

4 Channel Input RTD Base Block - 1790P-T4R0

Simplified Schematic

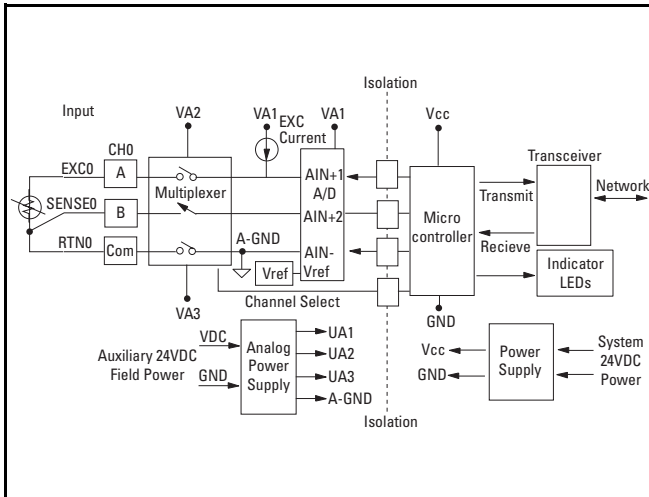

Wiring Diagram for Terminal Block

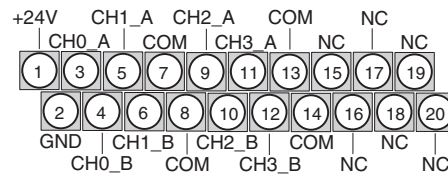

- Wire pin 1 to Field Power (+) 24Vdc
- Wire pin 2 to Field Power (-) GND

Block Specifications

1790P-T4R0				
Inputs per module	4 channel, RTD/Resistance Input			
Input Range	1-625 ohm			
Sensors Supported	Sensor Type	Degree	Counts	Resolution
	Resistance 100mΩ	1 to 625Ω	10 to 6250	100mΩ
	Resistance 10mΩ	1 to 327Ω	100 to 32700	10mΩ
	100ohm Pt/α =0.00385	-200 to +850°C	-2000 to +8500	0.1°C
	200ohm Pt/α =0.00385	-200 to +850°C	-2000 to +8500	0.1°C
	500ohm Pt/α =0.00385	-200 to +650°C	-2000 to +6500	0.1°C
	100ohm Pt/α =0.003916	-200 to +640°C	-2000 to +6400	0.1°C
	200ohm Pt/α =0.003916	-200 to +640°C	-2000 to +6400	0.1°C
	500ohm Pt/α =0.003916	-200 to +640°C	-2000 to +6400	0.1°C
	100ohm Nickel	-60 to 250°C	-600 to 2500	0.1°C
	120ohm Nickel	-80 to 260°C	-800 to 2600	0.1°C
	200ohm Nickel	-60 to 250°C	-600 to 2500	0.1°C
	500ohm Nickel	-60 to 250°C	-600 to 2500	0.1°C
Resolution	16 bits across 625ohms, 0.1°C/bit or 0.1°F/bit (RTD Sensors) 20bit Sigma-Delta modulation converter			
Data Format	16 bit Integer (2's compliment)			
Module Scan Time	8ms/channel @ Notch Filter = 60Hz			
Overall accuracy	0.2% Full scale @0°C-55°C			
Settable Notch Filter	10Hz (default), 25Hz, 50Hz, 60Hz, 100Hz, 250Hz, 500Hz			
Open Wire Detection	Out of range, open wiring			
Excitation Current	1mA			
Input Impedance	5M ohm			
PROFIBUS Power	Supply voltage - 24V dc nominal Voltage range - 19.2-28.8V dc Power dissipation - 2W maximum @ 28.8V dc			
Field Power	Supply Voltage - 24Vdc nominal Voltage Range - 21.6-26.4V dc (±10%) Power Dissipation - 1.5W maximum @26.4V dc			
Isolation	I/O to logic: photocoupler isolation Isolation voltage: Type Test 1250V ac rms for 60 seconds PROFIBUS to logic: non-isolated Field power: non-isolated			
Indicators	4 red/green I/O status			
Wiring	Terminal block (M3.0) - screw torque: 7 inch-pounds maximum (use copper or copper-clad aluminum conductors)			

IMPORTANT: This module does not support any expansion modules.

Word/Bit Descriptions

Word	Decimal Bit	Description
Read Word 0	Bits 00-15	Channel 0 input data
Read Word 1	Bits 00-15	Channel 1 input data
Read Word 2	Bits 00-15	Channel 2 input data
Read Word 3	Bits 00-15	Channel 3 input data
	Bits 00-03	Underrange for individual channels - Bit 00 corresponds to input channel 0, bit 01 corresponds to input channel 1 and so on. When set (1) the input signal is below the input channel's minimum range.
	Bits 04-07	Not used: Set to 0
Read Word 4	Bits 08-11	Overrange for individual channels - Bit 08 corresponds to input channel 0, bit 09 corresponds to input channel 1 and so on. When set (1) the input signal is above the input channel's maximum range, or open RTD is detected.
	Bits 12-15	Not used: Set to 0

Input Data File

Word	Bit Position															
	15	14	13	12	11	10	9	8	7	6	5	4	3	2	1	0
0	RTD Input Data Channel 0															
1	RTD Input Data Channel 1															
2	RTD Input Data Channel 2															
3	RTD Input Data Channel 3															
4	Not Used				S	S	S	S	Not Used				S	S	S	S
					11	10	9	8					3	2	1	0

4 Channel Input Thermocouple Base Block - 1790P-T4T0

Simplified Schematic

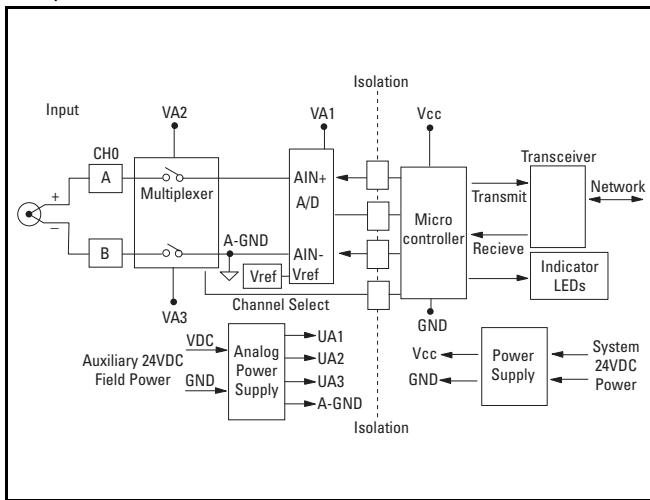

Wiring Diagram for Terminal Block

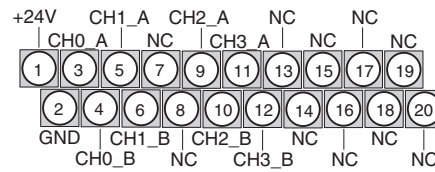

- Wire pin 1 to Field Power (+) 24Vdc
- Wire pin 2 to Field Power (-) GND

Block Specifications

1790P-T4T0			
Inputs per module	4 channel, Thermocouple/mV Input		
Input Range	±76.50mV		
Sensors Supported	Sensor Type	Range	Scaling
	Voltage 10µV	-76.50 to +76.50mV	-7650 to +7650
	Type B	300 to 1800°C	3000 to 18000
	Type E	-270 to 1000°C	-2700 to 10000
	Type J	-210 to 1200°C	-2100 to 12000
	Type K	-270 to 1370°C	-2700 to 13700
	Type R	-50 to 1768°C	-500 to 17680
	Type S	-50 to 1768°C	-500 to 17680
	Type T	-270 to 400°C	-2700 to 4000
	Type N	-270 to 1300°C	-2700 to 13000
Resolution	16 bits, 0.1°C/bit or 0.1°F/bit (Thermocouple Sensors) 20bit Sigma-Delta modulation converter		
Data Format	16 bit Integer (2's compliment)		
Module Scan Time	140ms/channel @ Notch Filter = 60Hz		
Overall accuracy	0.2% Full scale @0°C-55°C		
Settable Notch Filter	10Hz (default), 25Hz, 50Hz, 60Hz, 100Hz, 250Hz, 500Hz		
Open Wire Detection	Out of range, open wiring		
Cold Junction Compensation Range	0 to 70°C		
Input Impedance	5M ohm		

Word/Bit Descriptions

Word	Decimal Bit	Description
Read Word 0	Bits 00-15	Channel 0 input data
Read Word 1	Bits 00-15	Channel 1 input data
Read Word 2	Bits 00-15	Channel 2 input data
Read Word 3	Bits 00-15	Channel 3 input data
Read Word 4	Bits 00-03	Underrange for individual channels - Bit 00 corresponds to input channel 0, bit 01 corresponds to input channel 1 and so on. When set (1) the input signal is below the input channel's minimum range.
	Bits 04-07	Not used: Set to 0
	Bits 08-11	Overrange for individual channels - Bit 08 corresponds to input channel 0, bit 09 corresponds to input channel 1 and so on. When set (1) the input signal is above the input channel's maximum range, or open RTD is detected.
	Bits 12-15	Not used: Set to 0

Input Data File

Word	Bit Position															
	15	14	13	12	11	10	9	8	7	6	5	4	3	2	1	0
0	Thermocouple Input Data Channel 0															
1	Thermocouple Input Data Channel 1															
2	Thermocouple Input Data Channel 2															
3	Thermocouple Input Data Channel 3															
4	Not Used	S	S	S	S	S	S	S	S	S	S	S	S	S	S	S

General Specifications

PROFIBUS Power	Supply voltage - 24V dc nominal Voltage range - 11-28.8V dc Power dissipation - 2W maximum @ 28.8V dc
Field Power	Supply Voltage - 24Vdc nominal Voltage Range - 21.6-26.4V dc (±10%) Power Dissipation - 1.5W maximum @26.4V dc
Isolation	I/O to logic: photocoupler isolation Isolation voltage: Type Test 1250V ac rms for 60 seconds PROFIBUS to logic: non-isolated Field power: non-isolated
Indicators	4 red/green I/O status
Wiring	Terminal block (M3.0) - screw torque: 7 inch-pounds maximum (use copper or copper-clad aluminum conductors)

IMPORTANT: This module does not support any expansion modules.

24VDC 16 Universal Input Expansion Block - 1790-T16BV0X

Simplified Schematic

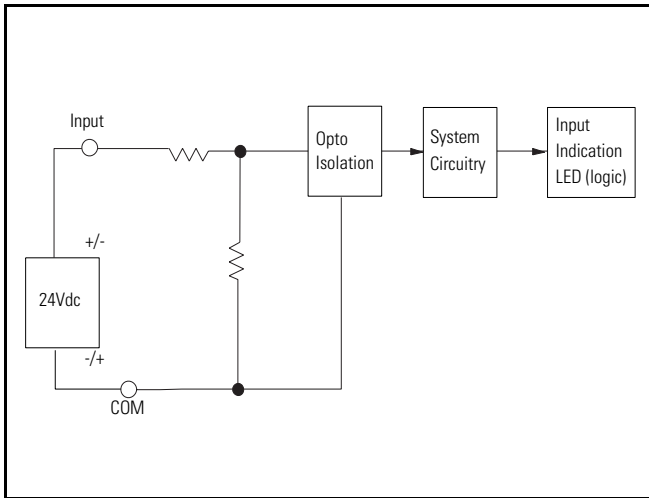

I/O Memory Mapping - Input Data File

Byte	Bit Position							
	7	6	5	4	3	2	1	0
0	IN7	IN6	IN5	IN4	IN3	IN2	IN1	IN0
1	IN15	IN14	IN13	IN12	IN11	IN10	IN9	IN8

Wiring Diagram for Terminal Block

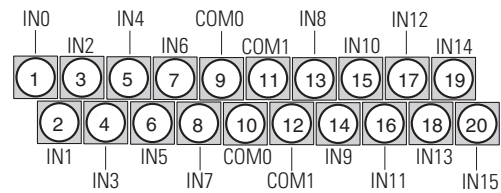

- **For inputs 0-7: Sinking inputs** - wire COM 0 (pin 9) to Field Power (-) GND
Sourcing inputs - wire COM 0 (pin 9) to Field Power (+) 24V dc
- **For inputs 8-15: Sinking inputs** - wire COM 1 (pin 11) to Field Power (-) GND
Sourcing inputs - wire COM 1 (pin 11) to Field Power (+) 24V dc
Note: both COM 0 are internally connected - COM 0 is used for inputs 0-7, COM 1 is used for inputs 8-15. Both COM 1 are internally connected.

Block Specifications

1790-TBV0X	
Inputs per block	16 points, sinking or sourcing
On-state voltage	9.6V dc minimum 24V dc nominal 28.8V dc maximum
Off-state voltage	5.0V dc maximum
On-state current	8mA maximum per channel @ 28.8V dc
Nominal input impedance	4.8K Ω
Indicators	16 green input status
Common type	8 points/8COM (non-polarity)
General Specifications	
Isolation	I/O to logic: photocoupler isolation Isolation voltage: 1250V ac rms DeviceNet to logic: non-isolated DeviceNet power: non-isolated
Wiring	Terminal block (M3.0) - screw torque: 7 inch-pounds maximum (use copper or copper-clad aluminum conductors)

24VDC 16 Sourcing Output Expansion Block - 1790-T0B16X

Simplified Schematic

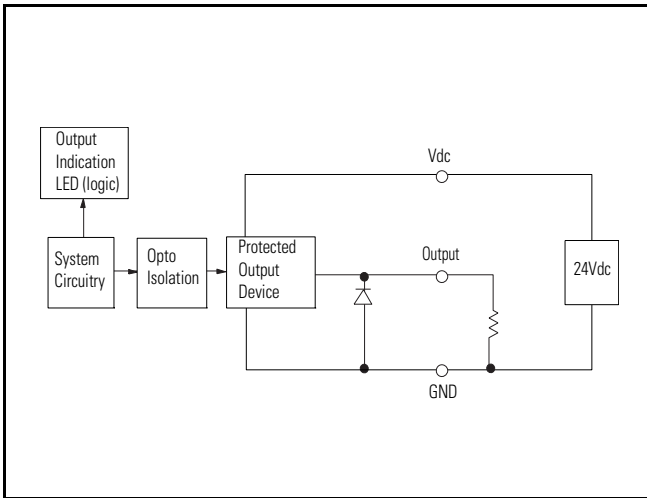

Wiring Diagram for Terminal Block

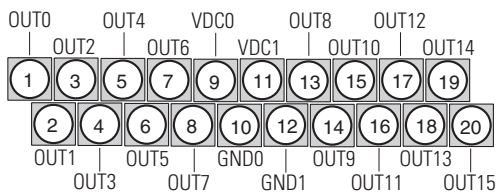

- **Sourcing outputs** - wire VDC0 (pin 9) and VDC1 (pin 11) to Field Power (+) 24V dc, wire GND0 (pin 10) and GND1 (pin 12) to Field Power (-) GND

I/O Memory Mapping - Output Data File

Byte	Bit Position							
	7	6	5	4	3	2	1	0
0	OUT7	OUT6	OUT5	OUT4	OUT3	OUT2	OUT1	OUT0
1	OUT15	OUT14	OUT13	OUT12	OUT11	OUT10	OUT9	OUT8

Block Specifications

1790-T0B16X	
Outputs per block	16 points non-isolated, sourcing
On-state voltage	10V dc minimum 24V dc nominal 28.8V dc maximum
On-state voltage drop	0.5V dc maximum
On-state current	1mA minimum per channel
Off-state voltage	28.8V dc maximum
Off-state leakage	0.5mA maximum
Output signal delay	Off to On: 0.5ms maximum On to Off: 1.0ms maximum
Indicators	16 green status
Output current rating	Maximum 0.5A per output 4.0A maximum per common
Common type	8 points/8COM

General Specifications	
Field Power	Supply voltage - 24V dc nominal Voltage range - 10-28.8V dc Power dissipation - 6mA @ 28.8V dc per point
Isolation	I/O to logic: photocoupler isolation Isolation voltage: 1250V ac rms
Wiring	Terminal block (M3.0) - screw torque: 7 inch-pounds maximum (use copper or copper-clad aluminum conductors)

24VDC 16 Sinking Output Expansion Block - 1790-T0V16X

Simplified Schematic

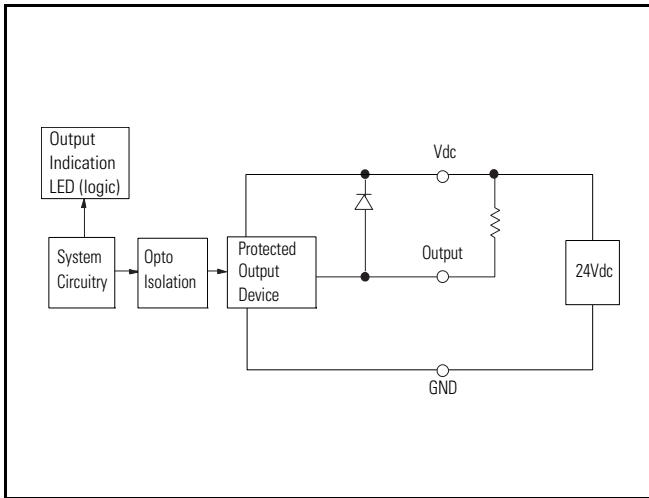

Wiring Diagram for Terminal Block

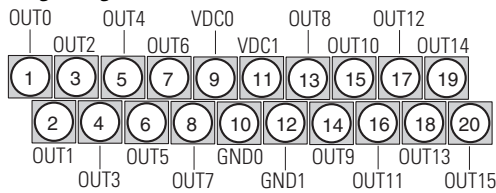

- **Sinking outputs** - wire VDC0 (pin 9) and VDC1 (pin 11) to Field Power (+) 24V dc, wire GND0 (pin 10) and GND1 (pin 12) to Field Power (-) GND

I/O Memory Mapping - Output Data File

Byte	Bit Position							
	7	6	5	4	3	2	1	0
0	OUT7	OUT6	OUT5	OUT4	OUT3	OUT2	OUT1	OUT0
1	OUT15	OUT14	OUT13	OUT12	OUT11	OUT10	OUT9	OUT8

Block Specifications

1790-T0V16X	
Outputs per block	16 points non-isolated, sinking
On-state voltage	10V dc minimum 24V dc nominal 28.8V dc maximum
On-state voltage drop	0.5V dc maximum
On-state current	1mA minimum per channel
Off-state voltage	28.8V dc maximum
Off-state leakage	0.5mA maximum
Output signal delay	Off to On: 0.5ms maximum On to Off: 1.0ms maximum
Indicators	16 green status
Output current rating	Maximum 0.5A per output 4.0A maximum per common
Common type	8 points/2COM
General Specifications	
Field Power	Supply voltage - 24V dc nominal Voltage range - 10-28.8V dc Power dissipation - 6mA @ 28.8V dc per point
Isolation	I/O to logic: photocoupler isolation Isolation voltage: 1250V ac rms
Wiring	Terminal block (M3.0) - screw torque: 7 inch-pounds maximum (use copper or copper-clad aluminum conductors)

120VAC 8 Input Expansion Block - 1790-T8A0X

Simplified Schematic

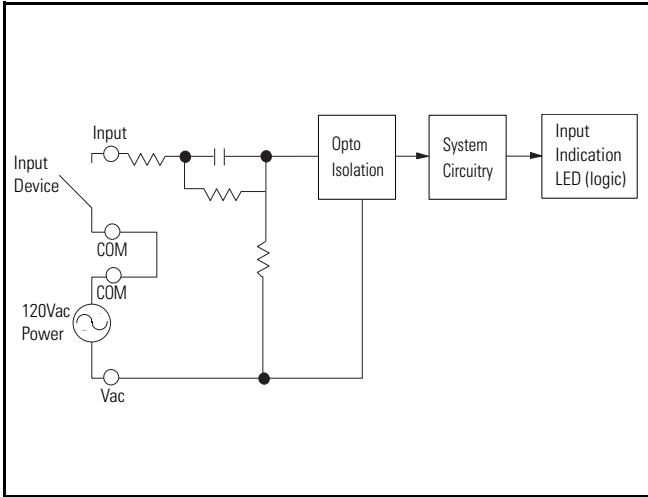

Wiring Diagram for Terminal Block

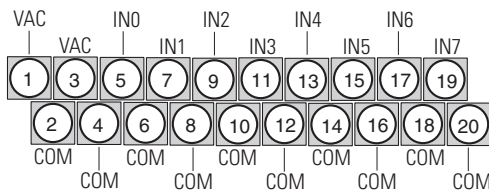

- Wire 120Vac Field Power to VAC (pin 1) and COM (pin 2)
Note: all VAC are internally connected. All COM are internally connected.

I/O Memory Mapping - Input Data File

Byte	Bit Position							
	7	6	5	4	3	2	1	0
0	IN7	IN6	IN5	IN4	IN3	IN2	IN1	IN0

Block Specifications

1790-T8A0X	
Inputs per block	8 points non-isolated
On-state voltage range	79V ac minimum 110V ac nominal 132V ac maximum
Input impedance	18K ohm
On-state current	9mA maximum @132V ac
Off-state voltage	45V ac maximum
Input signal delay	10ms off to on 30ms maximum on to off
Indicators	8 green input status
Common type	8 points/8COM
General Specifications	
External AC power supply	Supply voltage - 110V rms, 60Hz Voltage range - 85-132Vrms, 47-63Hz Power dissipation - 3W @ 132Vac
Isolation	I/O to logic: photocoupler isolation Isolation voltage: 1250V ac rms/V ac Field power: non-isolation
Wiring	Terminal block (M3.0) - screw torque: 7 inch-pounds maximum (use copper or copper-clad aluminum conductors)
Recommended Fusing	1A, 250V, Normal Blow

120VAC, 8 Output Expansion Block - 1790-T0A8X

Simplified Schematic

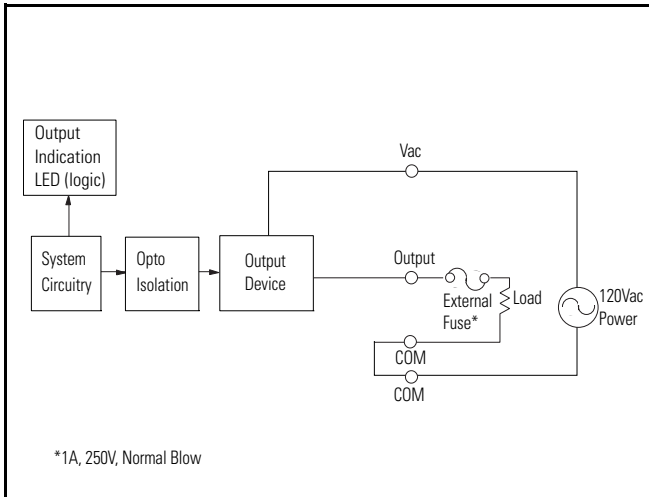

Wiring Diagram for Terminal Block

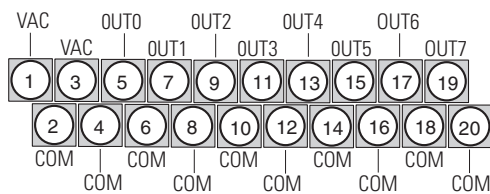

- Wire 120Vac Field Power to VAC (pin 1) and COM (pin 2)
Note: all VAC are internally connected. All COM are internally connected.

I/O Memory Mapping - Output Data File

Byte	Bit Position							
	7	6	5	4	3	2	1	0
0	OUT7	OUT6	OUT5	OUT4	OUT3	OUT2	OUT1	OUT0

Block Specifications

1790-T0A8X	
Outputs per expansion block	8 points non-isolated
Load voltage range	15-132Vrms
Maximum load current	0.5Arms
Minimum load current	10mArms
Max off-state leakage current	1.0mArms @ 100Vrms 60Hz
Max on-state voltage drop	1.3Vrms @ max load
Maximum operate time	1mS
Maximum release	1/2 cycle + 1 mS
Insulation resistance	Minimum 1,000MΩ (for input-output)
Dielectric strength	2500 Vrms 1 minute (for input-output)
Input signal delay	10ms off to on 30ms maximum on to off
Indicators	8 green input status
Common type	8 points/8COM
General Specifications	
External AC power supply	Supply voltage - 110V rms, 60Hz Voltage range - 15-132Vrms, 60Hz Power dissipation - 5.2W @ rated current
Isolation	I/O to logic: photocoupler isolation Isolation voltage: 1250V ac rms/V ac Field power: non-isolation
Wiring	Terminal block (M3.0) - screw torque: 7 inch-pounds maximum (use copper or copper-clad aluminum conductors)

Notes:

Notes:

Notes:

Rockwell Automation Support

Rockwell Automation provides technical information on the Web to assist you in using its products. At <http://support.rockwellautomation.com>, you can find technical manuals, a knowledge base of FAQs, technical and application notes, sample code and links to software service packs, and a MySupport feature that you can customize to make the best use of these tools.

For an additional level of technical phone support for installation, configuration, and troubleshooting, we offer TechConnect Support programs. For more information, contact your local distributor or Rockwell Automation representative, or visit <http://support.rockwellautomation.com>.

Installation Assistance

If you experience a problem with a hardware module within the first 24 hours of installation, please review the information that's contained in this manual. You can also contact a special Customer Support number for initial help in getting your module up and running.

United States	1.440.646.3434 Monday – Friday, 8am – 5pm EST
Outside United States	Please contact your local Rockwell Automation representative for any technical support issues.

New Product Satisfaction Return

Rockwell tests all of its products to ensure that they are fully operational when shipped from the manufacturing facility. However, if your product is not functioning, it may need to be returned.

United States	Contact your distributor. You must provide a Customer Support case number (see phone number above to obtain one) to your distributor in order to complete the return process.
Outside United States	Please contact your local Rockwell Automation representative for return procedure.

Allen-Bradley, FLEX I/O, ControlLogix, PLC, PLC-5 and SLC are trademarks of Rockwell Automation, Inc. Trademarks not belonging to Rockwell Automation are property of their respective companies.

www.rockwellautomation.com

Power, Control and Information Solutions Headquarters

Americas: Rockwell Automation, 1201 South Second Street, Milwaukee, WI 53204-2496 USA, Tel: (1) 414.382.2000, Fax: (1) 414.382.4444

Europe/Middle East/Africa: Rockwell Automation, Vorstlaan/Boulevard du Souverain 36, 1170 Brussels, Belgium, Tel: (32) 2 663 0600, Fax: (32) 2 663 0640

Asia Pacific: Rockwell Automation, Level 14, Core F, Cyberport 3, 100 Cyberport Road, Hong Kong, Tel: (852) 2887 4788, Fax: (852) 2508 1846