

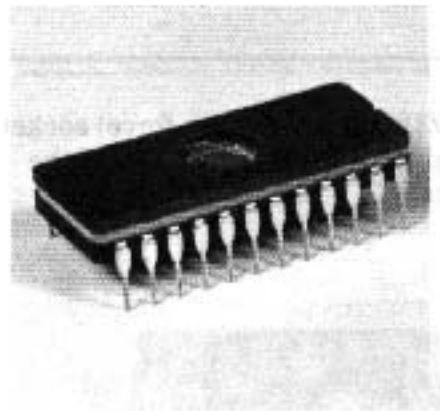

## **Allen-Bradley EPROM for Series A Mini-PLC-2/15 Processor**

(Cat. No. 1770-XP)

### Product Data



### **Description**

The EPROM (Erasable Programmable Read Only Memory) is a 24-pin, UV erasable memory chip that provides a series A Mini-PLC-2/15 Processor Module (cat. no. 1772-LV) with a 2K word non-volatile backup memory (figure 1).

**Figure 1  
EPROM (Cat. No. 1770-XP)**

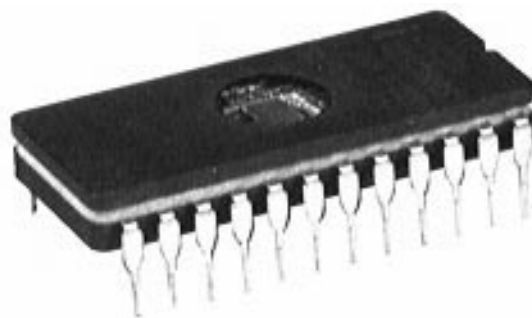

Compatibility of various EPROMs with the series A and B Mini-PLC-2/15 processor modules is illustrated in table A.

**Table A**  
**EPROM Compatibility**

EPROM Cat. No.	EPROM Functions Compatible with Series A Mini-PLC-2/15 Processor Module	EPROM Functions Compatible with Series B Mini-PLC-2/15 Processor Module
1770-XP	<ul style="list-style-type: none"> <li>▪ Download from EPROM.</li> <li>▪ Program the EPROM.</li> </ul>	<ul style="list-style-type: none"> <li>▪ Download from EPROM.</li> </ul>
1770-XU	<ul style="list-style-type: none"> <li>▪ Download from EPROM.</li> </ul>	<ul style="list-style-type: none"> <li>▪ Download from EPROM.</li> <li>▪ Program the EPROM.</li> </ul>
1770-AF1, -AF2, -AF3, -AF4	<ul style="list-style-type: none"> <li>▪ Download from EPROM.</li> <li>▪ Execute read-only EAF instruction.</li> </ul>	<ul style="list-style-type: none"> <li>▪ Download from EPROM.</li> <li>▪ Program the EPROM.</li> <li>▪ Execute read-only EAF instruction.</li> </ul>

Although EPROM memory is retained until erased, use battery backup for the RAM. This will ensure that data table values are not reset to their initial start-up values after a power loss.

The EPROM fits into a 28-pin ZIF (zero insertion force) socket, which is located under a hinged door at the lower side of the Mini-PLC-2/15 processor (figure 2).

**Figure 2**  
**EPROM Location**

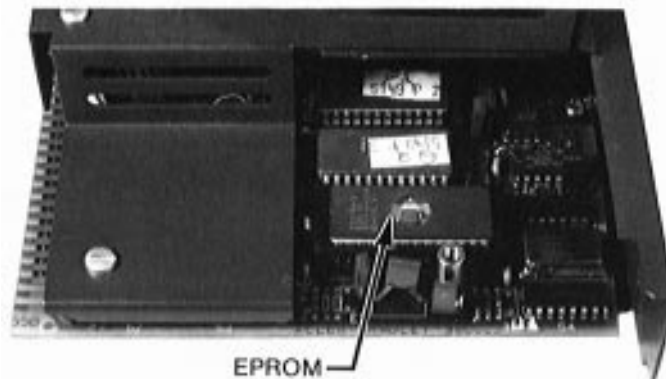

You can fully develop the ladder diagram program in the processor's 2K volatile CMOS RAM and then initiate the EPROM programming sequence to duplicate the data onto the EPROM. Any time power to the system is restored, the EPROM will automatically transfer the program back into the RAM when battery backup is not used or the RAM is invalid.

## Electrostatic Discharge

Under some conditions, electrostatic discharge can degrade performance or cause permanent damage. If you observe the following precautions you can guard against electrostatic damage.

- Touch a grounded object to discharge yourself before handling the chip.
- Handle the chip from both ends, taking care not to touch the pins.

## Handling

Avoid damage from electrostatic discharge. Bent or dirty pins can prevent proper EPROM operation. Store the EPROM in its shipping container. Also, cover the EPROM's transparent window with a opaque material to guard against accidental alteration of memory.

## Installation

On the underside of the EPROM door is a label that illustrates EPROM installation (figure 3).

**Figure 3**  
**EPROM Installation Label**

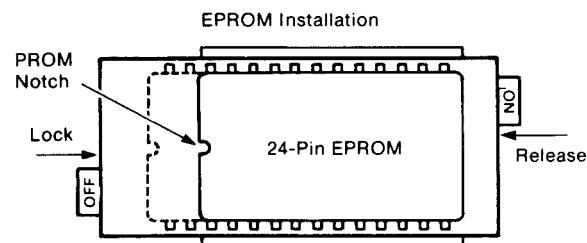

10819

To access the EPROM socket, remove the Mini-PLC-2/15 processor module from the I/O chassis. To maintain processor memory contents, connect an external battery pack (figure 4) to the processor with the Mini-Processor Transport Cable (cat. no. 1772-CD).

To install the EPROM, perform the following steps.

1. Turn the mode select switch to PROG.
2. To maintain processor memory contents, connect an external battery pack to the processor with the miniprocessor transport cable (figure 4).

**Figure 4**  
**External Battery Backup**

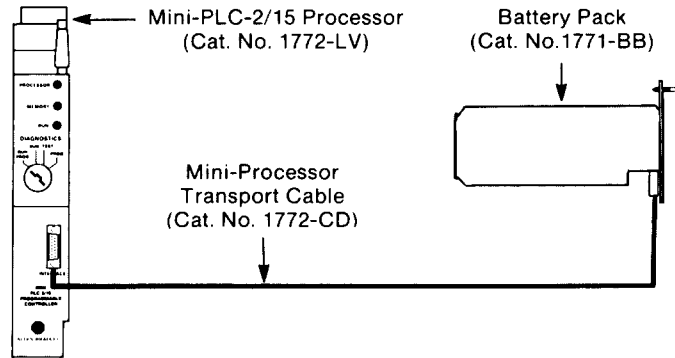

11182

3. Remove AC power from the I/O chassis power supply.
4. Remove the processor module from the I/O chassis.
5. Check all EPROM pins to ensure they are not bent or dirty.
6. Loosen the screw and lift the EPROM door.
7. Push the ON tab to the left to unlock the 28-pin ZIF socket (figure 3).
8. Position the EPROM so its notch faces the left side.
9. Line up the right side of the EPROM pin with the right side of the socket and seat the EPROM in the socket.
10. Lock the EPROM in place by pushing the OFF tab toward the right.
11. Close the EPROM door and tighten the screw.

## Removal

To remove the EPROM, perform the following steps:

1. Turn the mode select switch to PROG.
2. To maintain processor memory contents, connect an external battery pack to the processor with the miniprocessor transport cable (figure 4).
3. Remove AC power from the I/O chassis power supply.
4. Remove the processor module from the I/O chassis.

5. Loosen the screw, lift up the EPROM door and push the ON tab to the left to unlock the socket (figure 3).
6. Carefully remove the EPROM and store it in its shipping container.

## **EPROM Programming**

The Power Supply Assembly (cat. no. 1772-PA or -PAA) is needed to program the EPROM. The assembly consists of:

- 25.5V DC Power Supply (cat. no. 1770-P3 or -P3A)
- Power Supply Cable (cat. no. 1772-CA)

To program the EPROM, perform the following steps:

1. Follow the steps under Installation to install a blank EPROM in the processor module.
2. Turn the mode select switch to PROG and enter the ladder diagram program into the volatile RAM.
3. Test and verify proper program operation.
4. Connect one end of the power supply cable to the power supply (figure 5).
5. Place the power supply on a level surface such as the bottom of the enclosure.
6. Connect the 15-pin D-shell connector of the power supply cable to the INTERFACE socket on the processor module.
7. Connect the power supply's AC power cord to a grounded AC outlet. Once this connection is made, EPROM programming begins.

**Figure 5**  
**EPROM Programming Setup**

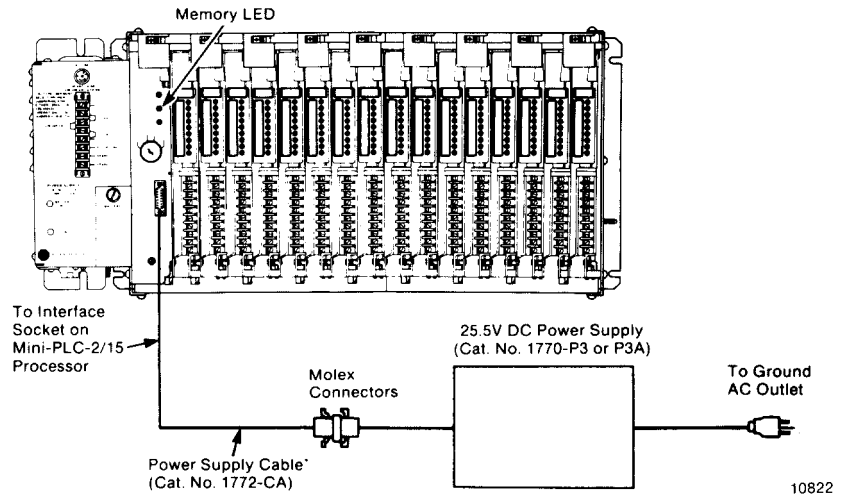

During EPROM programming, the MEMORY LED on the Mini-PLC-2/15 processor module will blink on and off. EPROM programming typically takes 5 minutes/2K memory. When EPROM programming is successfully completed, the MEMORY LED will turn off. If the MEMORY LED stays on after programming, either the EPROM is faulty or an error has occurred during EPROM programming.



**CAUTION:** When removing the EPROM from the processor, be sure the volatile RAM is supported with an external battery pack to avoid memory loss.

To correct an EPROM fault, remove the EPROM and either erase the EPROM with a UV light source and reinstall it or install another blank EPROM in the processor.

If you attempt EPROM programming when an EPROM is not installed or a programmed EPROM is installed, the MEMORY LED will turn on and stay on.

When a programmed EPROM is installed and a different program exists in the processor's volatile RAM, the EPROM program will be automatically transferred to the volatile RAM upon power-up. This writes over the program that was in volatile RAM.

## Erasing

The EPROM for the Mini-PLC-2/15 processor module is erased by exposing its window side to a UV light source with a power rating of at least 5000  $\mu\text{W}/\text{cm}^2$ . A recommended UV erasing system, the DE4 UV lamp by Ultra-Violet Products Inc.<sup>1</sup>, has a power rating of 5000  $\mu\text{W}/\text{cm}^2$ . Using this system, the EPROM is erased in approximately 50 minutes. This system also ensures that the UV exposure dose (UV power rating x exposure time) is at least 15 W-sec/cm<sup>2</sup>.



**CAUTION:** The UV light source should be checked periodically to ensure adequate intensities are maintained.

Shorter exposure times can be achieved using UV light sources that have a higher power rating. You must ensure that the UV exposure dose is at least 15 W-s/cm<sup>2</sup>. The following formula is used to calculate the exposure time (in seconds) with UV light sources that have different power ratings:

$$\text{Exposure Time} = \frac{15,000,000}{x} \text{ s}$$

where x is the power rating of the UV light source in  $\mu\text{W}/\text{cm}^2$ .

<sup>1</sup>Ultra-Violet Products, Inc.  
5100 Walnut Grove Ave., San Gabriel, CA 91778, Phone (213) 285-3123

## Specifications

### Programming Temperature

- 20°C to 30°C

### Nominal Storage Temperature

- -40° to 85°C

### Programming Time

- Approx. 5 min/2K

### UV Exposure Dose

- Minimum of 15 W-s/cm<sup>2</sup>

### UV Power Rating (UV Intensity)

- Minimum of 5000  $\mu\text{W}/\text{cm}^2$  at 253.7 nm



# ALLEN-BRADLEY

A ROCKWELL INTERNATIONAL COMPANY

As a subsidiary of Rockwell International, one of the world's largest technology companies — Allen-Bradley meets today's challenges of industrial automation with over 85 years of practical plant-floor experience. More than 11,000 employees throughout the world design, manufacture and apply a wide range of control and automation products and supporting services to help our customers continuously improve quality, productivity and time to market. These products and services not only control individual machines but integrate the manufacturing process, while providing access to vital plant floor data that can be used to support decision-making throughout the enterprise.

With offices in major cities worldwide

---

**WORLD  
HEADQUARTERS**  
Allen-Bradley  
1201 South Second Street  
Milwaukee, WI 53204 USA  
Tel: (1) 414 382-2000  
Telex: 43 11 016  
FAX: (1) 414 382-4444

**EUROPE/MIDDLE  
EAST/AFRICA  
HEADQUARTERS**  
Allen-Bradley Europe B.V.  
Amsterdamseweg 15  
1422 AC Uithoorn  
The Netherlands  
Tel: (31) 2975/43500  
Telex: (844) 18042  
FAX: (31) 2975/60222

**ASIA/PACIFIC  
HEADQUARTERS**  
Allen-Bradley (Hong Kong)  
Limited  
Room 1006, Block B, Sea  
View Estate  
28 Watson Road  
Hong Kong  
Tel: (852) 887-4788  
Telex: (780) 64347  
FAX: (852) 510-9436

**CANADA  
HEADQUARTERS**  
Allen-Bradley Canada  
Limited  
135 Dundas Street  
Cambridge, Ontario N1R  
5X1  
Canada  
Tel: (1) 519 623-1810  
FAX: (1) 519 623-8930

**LATIN AMERICA  
HEADQUARTERS**  
Allen-Bradley  
1201 South Second Street  
Milwaukee, WI 53204 USA  
Tel: (1) 414 382-2000  
Telex: 43 11 016  
FAX: (1) 414 382-2400