

PNEUMATIC TIMING UNITS

(Formerly Bulletin 896)

★40262-012-56 (Standard Temperature Range)
 ★40262-012-52 (Wide Temperature Range)
 X-311700 (Special w/Standard Temperature Range used w/Size 1 & 2 Series "K" Switches only)

CONTACT RATINGS — The timing unit is provided with a contact unit having one normally open and one normally closed contact. Contacts are silver of the quick make and break type. Contacts have a control circuit rating as follows:

| AC | | | | | | DC | |
|---|---------|-------|-----------------------------|-------------|-------|---------------|---------------|
| Maximum Contact Rating Per Pole NEMA Rating Designation A600 | | | | | | Voltage Range | Ampere Rating |
| Maximum AC Voltage | Amperes | | Continuous Carrying Current | Voltamperes | | | |
| | Make | Break | | Make | Break | | |
| 120 | 60 | 6 | 10 | 7200 | 720 | 115-125 | 0.4 |
| 240 | 30 | 3 | 10 | 7200 | 720 | | |
| 480 | 15 | 1.5 | 10 | 7200 | 720 | | |
| 600 | 12 | 1.2 | 10 | 7200 | 720 | 230-250 | 0.2 |

Note- Circuits wired to a contact unit **must** be of the same polarity.

| Complete Timing Unit | Temperature Range | Catalog Number |
|--|------------------------------|----------------|
| w/Standard Contact Unit | 0°F. to 104°F. (Standard) | 1496-N1 |
| w/Maintained Contact Unit | | 1496-N2 |
| w/Standard Contact Unit and Silicone Bellows | -20°F. to 150°F. (Wide) | 1496-N3 |
| w/Maintained Contact Unit and Silicone Bellows | | 1496-N4 |
| w/Standard Contact Unit used w/Size 1 and 2 Series "K" Switches Only | 0°F. to 104°F. (Standard) | ★40262-007-59 |

NOTE — Minimum temperature is based on the absence of freezing moisture or water.

Bellows — Air Inlet Filter

Bellows Assembly
 X-311256 (Standard Temperature Range)
 X-393588 (Wide Temperature Range)
 X-343982 (Special w/Standard Temperature Range used w/Size 1-2 Series "K" Switches only)

Filter Assembly (See Note Below)
 X-221325

IMPORTANT-The filter assembly is replaceable only on timing units identical to the unit illustrated here.

ORDERING INFORMATION — Your order cannot be entered unless the following information is given: Part Number description of part and the Catalog Number and Series Letter of timing unit. This instruction sheet applies also to the above units when used on control apparatus listed under other Bulletin Numbers.

NOTE — Parts indicated with (★) are recommended spare parts.
 *Added or changed since previous issue.

DESCRIPTION — The Bulletin 1496 Pneumatic Timing Unit is a mechanical-pneumatic device designed to produce timing in an electrical circuit. They have an adjustable timing range of 1/20 to 180 seconds, with a repetitive accuracy of approximately ± 10%. A minimum reset time of 75 milliseconds must be provided to attain the repetitive accuracy. Temperature variations have very little effect on their operation.

INSTALLATION — The Bulletin 1496 Pneumatic Timing Unit has a stroke of 5/16" and requires an operating force of only one (1) pound to reset the timing mechanism. For maximum life of the timing unit it is recommended that the operating force be matched as closely as possible to the operating characteristics of the timing unit. The mechanism or device used to reset the timing unit should produce only straight line motion parallel to the push rod of the timing unit. Any resetting device which produces a force perpendicular to the push rod of the timing unit will considerably shorten the life of the timer and impair its operation.

MOUNTING RECOMMENDATIONS — Several methods of mounting the timing unit may be employed. The sketches below will help you obtain the maximum life and repetitive accuracy from the timing unit.

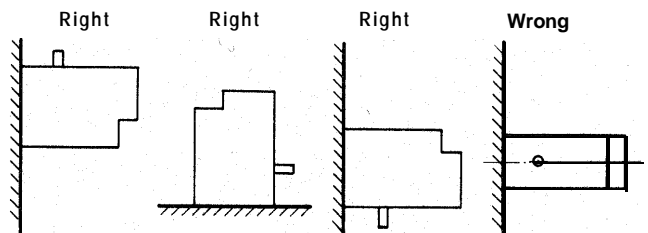

Notice in the sketch designated as "wrong" that the plane through the greatest area of the timing unit is parallel to the floor. This plane must always be perpendicular to the floor.

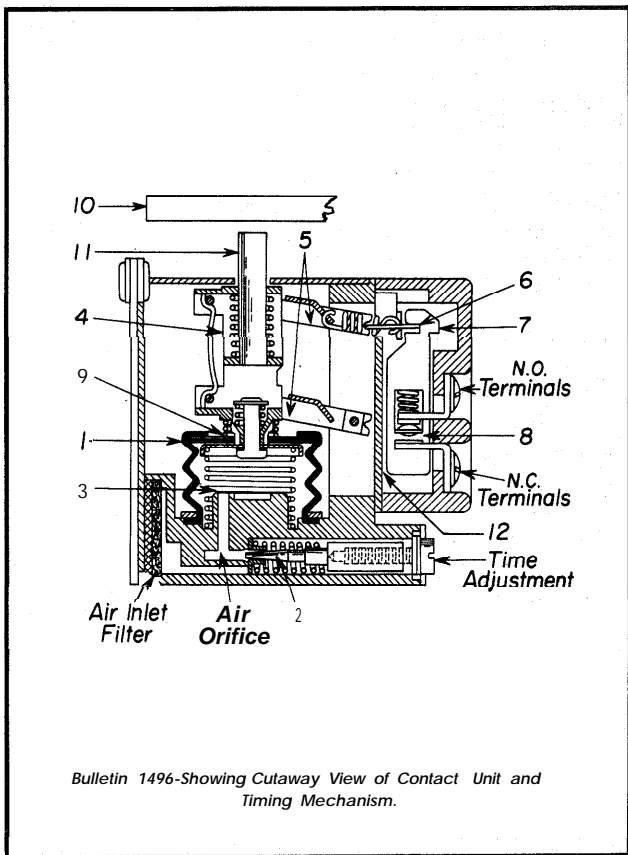

Bulletin 1496-Showing Cutaway View of Contact Unit and Timing Mechanism.

ACTION OF THE TIMING MECHANISM — When the external resetting device (10) is retracted from the push rod (11) it allows the spring (3) located inside the synthetic rubber bellows (1) to push the plunger (4) upward. As the plunger rises, it causes the over-center toggle mechanism (5) to move the snap action toggle blade (6) upward which in turn picks up the push plate (7) which carries the movable contacts (8).

The speed with which the bellows can expand is determined by the setting of the needle valve (2). If this needle valve is nearly closed, an appreciable length of time will be required for air to pass it and permit the bellows to expand. The setting of the needle valve determines the time interval which must elapse between operation of the actuator and expanding of the bellows to operate the contact unit.

When the push rod is again depressed, it forces the plunger to the lower position, exhausting the air through the release valve (9), and resetting the timer almost instantaneously.

***REPLACING CONTACT UNIT** — Should the contact unit, for any reason, be removed from the front of the timing mechanism, care must be taken to see that the toggle blade (6) is in the down position when the unit is replaced. This enables the blade to fit into the notch in the push plate (7), as shown in the illustration. Hold down the push rod (11) and flip the toggle blade (6) down. Then put the contact unit in position, being sure that the "loose" black phenolic insulation that isolates the contact cavity, is in place. Secure with the two mounting screws. After assembly, check for normal contact operation.

*Added or changed since previous issue.



ALLEN-BRADLEY
Milwaukee, Wisconsin 53204

