



## Instructions for ATEX Approved PowerFlex 700H Drives in Group II Category (2) Applications with ATEX Approved Motors

### General Information

This document provides information on operation of an ATEX<sup>(1)</sup> Approved drive and ATEX approved motor. The motor is located in a defined hazardous environment, while the drive is not. A protective system is required to stop current flow to the motor when an over temperature condition has been sensed in the motor. When sensed, the drive will go into a stop condition. To restart the drive, the over temperature condition must be resolved, followed by a valid start command to the drive. The PowerFlex 700H drive must have the 20C-DG1 option board installed in slot B of the control assembly for ATEX applications. Consult the *PowerFlex 700S/H High Power Drives Installation Frame 9-13*, publication PFLEX-IN006..., for option board installation instructions, if necessary.

The drive is manufactured under the guidelines of the ATEX directive 94/9/EC. These drives are in Group II Category (2) Applications with ATEX Approved Motors. Certification of the drive for the ATEX group and category on its nameplate requires installation, operation, and maintenance according to this document and to the requirements found in the *PowerFlex 700S/H High Power Drives Installation Frame 9-13*, publication PFLEX-IN006... and appropriate Motor Instruction Manual(s).



---

**ATTENTION:** Operation of this ATEX certified drive with an ATEX certified motor that is located in a hazardous environment requires additional installation, operation, and maintenance procedures beyond those stated in the standard user manual. Equipment damage and/or personal injury may result if all additional instructions in this document are not observed.

---

### Motor Requirements

- The motor must be manufactured under the guidelines of the ATEX directive 94/9/EC. It must be installed, operated, and maintained per the motor manufacturer supplied instructions.
- Only motors with nameplates marked for use on an inverter power source, and labeled for specific hazardous areas, may be used in hazardous areas on inverter (variable frequency) power.
- When the motor is indicated for ATEX Group II Category 2 for use in gas environments (Category 2G) the motor must be of flameproof construction, EEx d (according to EN50018) or Ex d (according to EN60079-1 or IEC60079-1). Group II motors are marked with a temperature or a temperature code.

<sup>(1)</sup> ATEX is the French acronym for "Atmosphères Explosibles" which translates to Explosive Atmospheres in English.

- When the motor is indicated for ATEX Group II Category 2 for use in dust environments (Category 2D) the motor must be protected by an enclosure (according to EN50281-1-1 or according to IEC61241-1: Ex tD). Group II motors are marked with a temperature.
- The motor over temperature signal supplied to the drive must be a normally closed contact (open during over temperature condition) compatible with the digital (logic) input circuitry of the drive. If multiple sensors are required in the motor, the connection at the drive must be the resultant of all required contacts wired in series.
- Refer to all product markings for additional cautions that may apply.
- Typical motor markings are contained on a motor certification nameplate similar to the sample below.

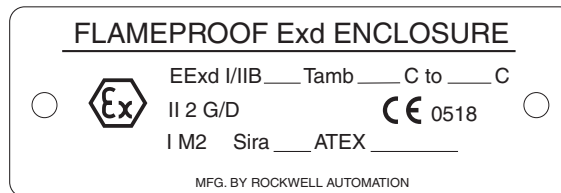

## Drive Wiring

**Important:** ATEX certification of this drive requires that two separate inputs be configured to monitor a normally closed over temperature contact (or multiple contacts wired in series) presented to the drive from the motor.

The first input must energize SD1 input (terminals X5-1 & X5-2) on the drive option board (20C-DG1). The second input must energize the SD2 input (terminals X5-3 & X5-4) on the option board. This option board must be installed in the drive for ATEX applications. It is offered with 24V DC input only. Both input signals are wired with respect to the drive's digital input common when using a control board with 24V I/O. Refer to the *PowerFlex 700S/H High Power Drives Installation Frame 9-13*, publication PFLEX-IN006..., regarding setup for either internal or external 24V logic power. Motor supplied contacts must have ratings compatible with the input circuit ratings and applied voltage level of the drive.

### Terminal Descriptions

Term. Blk.	No.	Signal	Description
X5	1	SD1+	Isolated Disable input 1 +24V +/-20% 10... 15mA
	2	SD1-	Virtual GND 1
	3	SD2+	Isolated Disable input 2 +24V +/-20% 10... 15mA
	4	SD2-	Virtual GND 2
X2	21	Digital Out 1 - N.C.	<u>Max. Resistive Load:</u> 240V ac / 30V dc - 1200VA, 150W Max. Current: 5A, Min. Load: 10mA <u>Max. Inductive Load:</u>
	22	Digital Out 1 Common	
	23	Digital Out 1 - N.O.	
X3	25	Digital Out 2 Common	240V ac / 30V dc - 8400VA, 105W Max. Current: 3.5A, Min. Load: 10mA
	26	Digital Out 2 N.O.	
X7	28	TI1+	Thermistor input: $R_{trip} \geq 4.0 \text{ k}\Omega$ (PTC)
	29	TI1-	

**Important:** The drive will not run unless one of the following conditions is met:

- A wire must be installed in the hardware thermistor input (X7-28 and X7-29) and the thermistor short circuit supervisor jumper X10 must be installed in the OFF position.

OR

- A thermistor must be installed in the hardware thermistor input (X7-28 and X7-29).

### Wiring Example - Internal 24V Power Supply

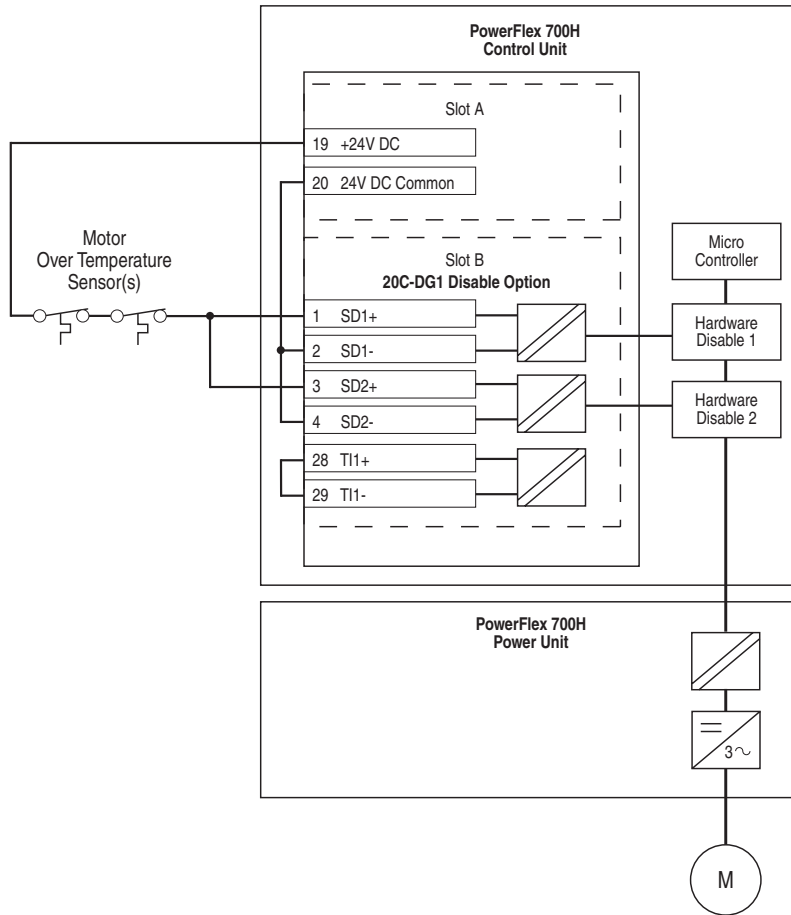

### Configuration

The PowerFlex 700H drive can be configured in one of five ways when using the 20C-DG1 option board, each resulting in the drive being put into a Gate Disabled state when digital inputs are removed or the thermistor is out of range.

#### 1. Gate Disable Fault (59):

Configured by setting bit 10 “Gate Disable” of parameter 238 [Fault Config1].

If both digital inputs open, the drive output will be disabled and the motor will coast to a stop. The drive HIM will display fault 59 “Gate Disable”.

When the condition is cleared, the fault can be reset and the drive can be restarted.

If only one digital input opens, the drive output will be disabled and the motor will coast to a stop. Refer to the table in the “Verify Operation” section on [page 6](#) for a description of drive conditions and actions.

## 2. Gate Disable Alarm (59):

Configured by setting bit 15 “Gate Disable” of parameter 259 [Alarm Config1].

If both digital inputs open, the drive output will be disabled and the motor will coast to a stop. The drive HIM will display alarm 59 “Gate Disable”.

When the condition is cleared, the alarm will automatically clear in 10 seconds and the drive can be restarted.

If only one digital input opens, the drive output will be disabled and the motor will coast to a stop. Refer to the table in the “Verify Operation” section on [page 6](#) for a description of drive conditions and actions.

## 3. Neither of the “Gate Disable” bits, 10 in parameter 238 [Fault Config1] or 15 in parameter 259 [Alarm Config1], are set.

If both digital inputs open, the drive output will be disabled and the motor will coast to a stop. No fault or alarm indication will be given, but the Gate Disable status can be seen in bit 0 “Gate Disable” of parameter 359 [20C-DG1 Status].

When the condition is cleared, the drive can be restarted after 3 seconds.

If only one digital input opens, the drive will be disabled and the motor will coast to a stop. Refer to the table in the “Verify Operation” section on [page 6](#) for a description of drive conditions and actions.

## 4. Both “Gate Disable” bits, 10 in [Fault Config1] and 15 in [Alarm Config1], are set:

The Gate Disable fault takes precedence.

## 5. Thermistor Input:

If the thermistor input goes out of range, the drive output will be disabled and the motor will coast to a stop. The drive will display fault 60 “Hrdwr Therm” on the drive HIM.

When the condition is cleared, the fault can be reset and the drive can be restarted. This configuration requires that the two digital inputs remain closed to function.

## Removing the 20C-DG1 Option Board

During maintenance or service there may be a need to remove the 20C-DG1 option board.

The drive is designed to generate a non-resettable fault F10 “System Fault” if the option board is removed. The operator must manually change parameter 358 [20C-DG1 Remove] to 1- “Remove” and then back to 0 - “Ready” to clear and acknowledge the fault.

Once maintenance or service is completed and the 20C-DG1 option card has been reinstalled, the drive will recognize the option card on power-up.

## Verify Operation

At regular intervals during the life of the machine check the protective system for proper operation. Both channels shall be verified using the table below. How frequently the protective system is checked is dependent on the safety analysis of the machine section controlled by the drive.

Protective System Status	Drive In Gate Disable State	Drive In Gate Disable State	Drive In Gate Disable State	Drive Able To Run
<b>Channel Operation</b>				
<b>SD1</b> - terminals X5-1 & X5-2 Par 359 [20C-DG1 Status], bit 3 “No Enable CH1”	Bit 3 = 1 No Power Applied	Bit 3 = 0 Power Applied	Bit 3 = 1 No Power Applied	Bit 3 = 0 Power Applied
<b>SD2</b> - terminals X5-3 & X5-4 Par 359 [20C-DG1 Status], bit 4 “No Enable CH2”	Bit 4 = 1 No Power Applied	Bit 4 = 1 No Power Applied	Bit 4 = 0 Power Applied	Bit 4 = 0 Power Applied
<b>Description For Verification</b>				
<b>PowerFlex 700H Drive Status</b>	<b>Output Disabled</b>	<b>Output Disabled</b>	<b>Output Disabled</b>	<b>Output Enabled</b>
Par 359 [20C-DG1 Status], Bit 0 “Gate Disable” or Bits 2 “Unexp In Pro” and 15 “Unexp HW Pro”	Bit 0 = 1	Bit 2 = 1 Bit 15 = 1	Bit 2 = 1 Bit 15 = 1	Bit 0 = 0
Fault or Alarm	F59 “Gate Disable” (Fault or Alarm Based on drive set up)	F10 “System Fault”	F10 “System Fault”	None

U.S. Allen-Bradley Drives Technical Support - Tel: (1) 262.512.8176, Fax: (1) 262.512.2222, Email: support@drives.ra.rockwell.com, Online: www.ab.com/support/abdrives  
U.S. Reliance Drives Technical Support - Tel: (1) 800.726.8112, Online: www.reliance.com

[www.rockwellautomation.com](http://www.rockwellautomation.com)

### Power, Control and Information Solutions Headquarters

Americas: Rockwell Automation, 1201 South Second Street, Milwaukee, WI 53204-2496 USA, Tel: (1) 414.382.2000, Fax: (1) 414.382.4444  
Europe/Middle East/Africa: Rockwell Automation, Vorstlaan/Boulevard du Souverain 36, 1170 Brussels, Belgium, Tel: (32) 2 663 0600, Fax: (32) 2 663 0640  
Asia Pacific: Rockwell Automation, Level 14, Core F, Cyberport 3, 100 Cyberport Road, Hong Kong, Tel: (852) 2887 4788, Fax: (852) 2508 1846

### Motors, Drives and Power Transmission Solutions Headquarters

Americas: Rockwell Automation, 6040 Ponders Court, Greenville, SC 29615-4617 USA, Tel: (1) 864.297.4800, Fax: (1) 864.281.2433  
Europe/Middle East/Africa: Rockwell Automation, Herman-Heinrich-Gossen-Strasse 3, 50858 Köln, Germany, Tel: (49) 2234 379410, Fax: (49) 2234 3794164  
Asia Pacific: Rockwell Automation, 55 Newton Road, #11-01/02 Revenue House, Singapore 307987, Tel: (65) 6356 9077, Fax: (65) 6356 9011