



DriveLogix™ Controller Firmware Revision 11 / RSLogix 5000 Version 11

These release notes correspond to major revision 11, minor revision 14 of the DriveLogix controller firmware. Use this firmware release with:

Software Product:	Compatible Version:
RSLink software	2.31
RSLogix 5000 programming software	11.11
RSNetWorx for ControlNet software	3.23
RSNetWorx for DeviceNet software	3.21

Introduction

These release notes provide the following information:

For information about:	See page:
Before You Update Your System	2
DriveLogix Enhancements	2
Common Logix Enhancements	3
Common Changes	4
DriveLogix Changes	7
Corrected Anomalies	7
DriveLogix Restrictions	8
DH-485 Communications Recommendations	8
Controller Memory Considerations	9

Before You Update Your System

Before you update your controller or RSLogix 5000 software to this revision, do the following preliminary actions:

Is Your Controller Connected to a DH-485 Network?

If yes, then disconnect it from the DH-485 network *before* you update the firmware of the controller. If you update the firmware of a controller while it is connected to a DH-485 network, communication on the network may stop.

Is Your Controller Close to Its Limits of Memory?

This revision may require more memory than previous revisions. Before you upgrade to this revision, do the following:

1. Check the amount of unused memory that you have in the controller.
2. If your controller is close to its limits of memory, see “Controller Memory Considerations” on page 9 to determine how much additional memory you require.

DriveLogix Enhancements

This revision of the DriveLogix controller contains these new features:

- the Requested Packet Interval (RPI) of the PowerFlex 700S Drive may be set as low as 3.0 ms. This is the minimum allowed by RSLogix 5000 programming software. The default value in the programming software is 4.0 ms.
- support for EtherNet/IP™ connectivity using the 1788-ENBT EtherNet/IP communication daughtercard
- support for Non-Volatile Memory on the DriveLogix controller. Previously this feature was not available. This gives DriveLogix the ability to restore the controller’s last saved project without a battery.
- Flex I/O very high speed counter (1794-VHSC) is supported on the Local DIN rail
- support for a Memory Expansion option. This option provides additional SRAM and Flash, Non-Volatile memory.
 - 256K bytes of user available memory without memory option
 - 768K bytes of user available and flash memory with memory option
- support for DeviceNet connectivity using the 1788-DNBO Devicenet communication daughtercard
- support for 200V, 400V, and 600V PowerFlex 700S and 700Se drive interfaces

Common Logix Enhancements

- Specific software support has been added to support the 1794-IB32 and OB32 Flex I/O modules.

This revision of the DriveLogix controller contains the following new features:

Sequential Function Chart Programming Language

A sequential function chart (SFC) is similar to a flowchart of your process. It defines the steps or states through which your system progresses. Use the SFC to:

- organize the functional specification for your system
- program and control your system as a series of steps and transitions

A sequential function chart can contain these elements:

- steps
- transitions
- actions
- stops
- text boxes

New Instructions For Use with a Sequential Function Chart (SFC)

This instruction:	Lets you:
EQT	Set the state of a transition in an SFC true or false
SFP	Pause an executing SFC
SFR	Reset the execution of an SFC to a different step or stop

Structured Text Programming Language

Structured text is a textual programming language that uses statements to define what to execute. Structured text can contain these

- assignments
- expressions
- instructions
- constructs
- comments

You can either program structured text as a routine or embed the structured text with a sequential function chart.

Online Editing of Function Block Routines

This revision lets you edit function block routines (diagrams) while online with the controller.

- Online edits include changes to logic, sheet names, pin visibility, block locations, etc.
- You edit a function block routine the way you edit a ladder routine: start a pending edit, accept the edit, test the edit, and finally assemble the edit.

Common Changes

This revision of the DriveLogix controller contains the following changes:

SIZE Instruction Lets You Specify an Array Tag

The source for a SIZE instruction can now be an array tag. You no longer have to specify the first element in the array.

Use the Same Tag in Multiple IREFs and OREFs

You can use the same tag in multiple IREFs and an OREF in the same routine. Because the values of tags in IREFs are latched every scan through the routine, all IREFs will use the same value, even if an OREF obtains a different tag value during execution of the routine. In this example, if tagA has a value of 25.4 when the routine starts executing this scan, and Block_01 changes the value of tagA to 50.9, the second IREF wired into Block_02 will still use a value of 25.4 when Block_02 executes this scan. The new tagA value of 50.9 will not be used by any IREFs in this routine until the start of the next scan.

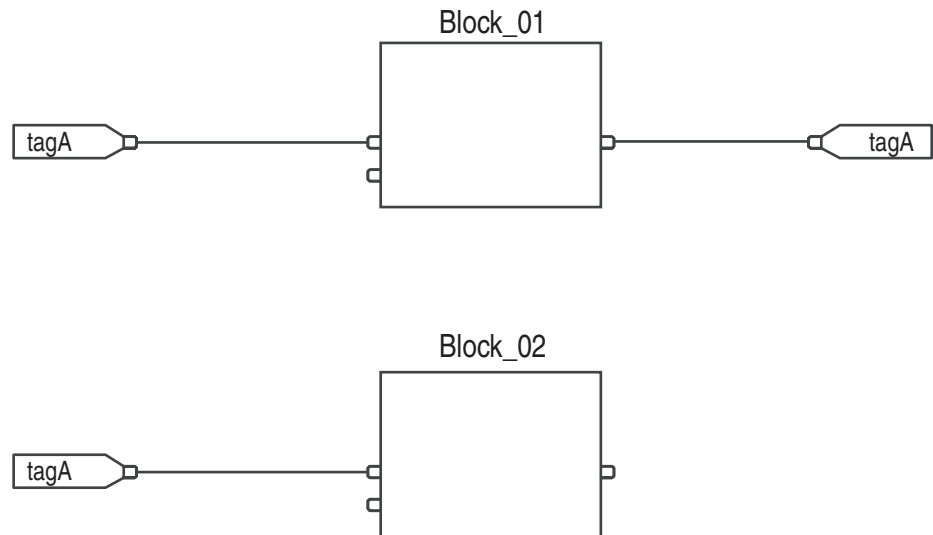

REAL Data Type Shows an Extra Digit of Precision

The REAL data type now shows a 32-bit (4-byte) IEEE floating-point value with the following range:

- $-3.40282347E38$ to $-1.17549435E-38$ (negative values)
- 0
- $1.17549435E-38$ to $3.40282347E38$ (positive values)

The REAL data type also stores \pm infinity, \pm NAN, and -IND, but the software display differs based on the display format.

Display Format:	Equivalent:	
Real	+infinite	1.\$
	- infinite	-1.\$
	+NAN	1.#QNAN
	-NAN	-1.#QNAN
	-indefinite	-1.#IND
Exponential	+infinite	1.#INF000e+000
	- infinite	-1.#INF000e+000
	+NAN	1.#QNAN00e+000
	-NAN	-1.#QNAN00e+000
	-indefinite	-1.#IND0000e+000

The software also stores and displays the IEEE subnormal range:

- $-1.17549421E-38$ to $-1.40129846E-45$ (negative values)
- $1.40129846E-45$ to $1.17549421E-38$ (positive values)

PIDE_AUTOTUNE Structure Contains New Status Bits

When you use the PIDE Auto Tune feature, it is possible to set up a tuning environment in which the auto tune procedure successfully completes but the results are unusable. To provide an indication that this occurred, the PIDE_AUTOTUNE structure includes new members. You still have the option of accepting the auto tune values.

To see if:	Examine this member of the PIDE_AUTOTUNE structure:	Explanation:
Observed PV change was too small	PVChangeTooSmall	The PV change seen as a result of the CV step change was very small. <ul style="list-style-type: none"> • Filter your PV to eliminate excessive noise, which could have caused the autotuner to mistake a noise spike for an actual PV response. • Make sure that the PIDE instruction is executing at an appropriate rate for your process. For example, if your process is a slow temperature loop, run your PIDE instruction in a slow (0.5s to 2s) periodic task. An execution rate that is too fast can cause the autotuner to mistake a noise spike right after the autotuner starts for an actual PV response.
Step size is too small	StepSizeTooSmall	The CV step size that you configured for the autotuner was very small. You might get better results if you autotune the loop again using a larger step size.
Process gain is too large	GainTooLarge	The autotuner identified your process as having a very large process gain. In other words, a small step change in CV output caused a very large change in PV. Make sure that your control actuator is properly sized for this application.
Process gain is too small	GainTooSmall	The autotuner identified your process as having a very small process gain. In other words, a step change in CV output caused only a very small change in PV. To get better results: <ul style="list-style-type: none"> • Filter your PV to eliminate excessive noise, which could have caused the autotuner to mistake a noise spike for an actual PV response. • Make sure that the PIDE instruction is executing at an appropriate rate for your process. For example, if your process is a slow temperature loop, run your PIDE instruction in a slow (0.5s to 2s) periodic task. An execution rate that is too fast can cause the autotuner to mistake a noise spike right after the autotuner starts for an actual PV response. • Make sure that your control actuator is properly sized for this application.
Dead time is too long	LongDeadTime	The autotuner identified your process as having a long dead time. In other words, it takes a long time between when the output of the loop changes and the PV starts to respond as a result of that change. This is often a result of having the sensor for your PV physically located far away from your actuator controlling the process. The autotuner will suggest a set of tuning constants, but standard PID control may have a difficult time controlling this process effectively.

You can also examine the bits of the `AtuneStatus` member for the same information:

For this member:	Examine this bit of the <code>AtuneStatus</code> member:
<code>PVChangeTooSmall</code>	27
<code>StepSizeTooSmall</code>	28
<code>GainTooLarge</code>	29
<code>GainTooSmall</code>	30
<code>LongDeadTime</code>	31

PLC5 Typed Read Message Errors If Destination Is Too Small

In a Message (MSG) instruction that is configured for *PLC5 Typed Read*, the instruction no longer executes if the Destination is too small for the Source data. If this occurs, the instruction sets the ER bit.

If a MSG instruction is configured for *PLC5 Typed Read* and the data type of the Source does not match the data type of the Destination, the instruction converts the Source to the data type of the Destination. For example, if the data type of the Source is INTs and the data type of the Destination is DINTs, the instruction converts the INTs to DINTs. In this example, the Destination requires one DINT element for each INT of the Source data.

In previous revisions, if a data conversion occurred but the Destination was too small, data beyond the Destination was overwritten. This may have caused the controller to fail during a download or online edit operation.

DriveLogix Changes

The PowerFlex 700S is no longer automatically placed in the I/O configuration of the DriveLogix controller. You must add the PowerFlex 700S drive to the configuration, in a manner similar to adding an I/O module. The Controller Organizer automatically places the drive in slot two.

Corrected Anomalies

This revision of the DriveLogix controller corrects the following anomalies:

Online Edit of Tags Might Have Caused Communication Failure

If you deleted an unused tag while online, you might have lost communication with the controller. RSLinx showed a Red X over the

controller and you were unable to communicate with the controller through either the serial port or another communication module.

The communication failure could have occurred immediately after you deleted the tag or later on in the execution of the project. A power cycle would temporarily clear the problem.

Size of the ASCII Buffer *No Longer* Limited to 255 Characters

You can set the size of the ASCII buffer of the serial port to any number of characters up to 65,536 characters. In previous revisions, a setting larger than 255 character caused ABL instructions to miss the termination character and set status bits to erroneous values.

DriveLogix Restrictions

This firmware version has these restrictions:

- Forcing is not supported between the PowerFlex 700S and DriveLogix. The forcing values can be set for the controller inputs and outputs. However, these values will not be used by the Logix Program nor will they be transmitted to the PowerFlex 700S.
- The minimum recommended Requested Packet Interval (RPI) setting for the local Flex I/O rail is 30 ms.

DH-485 Communications Recommendations

We recommend that you use DH-485 communications as follows:

- If you update the firmware of a controller while it is connected to a DH-485 network, communication on the network may stop. To prevent this, disconnect the controller from the DH-485 network *before* you update the firmware of the controller.
- Place a FlexLogix controller on a DH-485 network only when you need to add the controller to an existing system. For new systems, use a ControlNet network.
- While your system is running, use a DH-485 network to send messages between devices (e.g., controllers, PanelView terminals).
- To use RSLogix 5000 software over a DH-485 network (upload, download, monitor, edit while online), place all controllers in the program mode. Excessive traffic may make it impractical to use RSLogix 5000 software over this network while your system is running.

Controller Memory Considerations

This revision *may* require more memory than previous revisions. To estimate the additional memory that your project may require, use the following table:

If you have this firmware revision (add <i>all</i> that apply):	Then add the following memory requirements to your project:			Which comes from this type of memory:		
	Component	Increase per instance	I/O	expansion		
10.x or earlier	programs	12 bytes		✓		
	routines	16 bytes		✓		
9.x or earlier	tag that uses the MESSAGE data type	376 bytes		✓		
8.x or 9.x	produced or consumed axis	(-21.6K bytes)	✓			
	axis that <i>is not</i> produced or consumed	(-21.6K bytes)		✓		
8.x or earlier	output cam execution targets	5,404 bytes		✓		
	motion group	32 bytes		✓		
7.x or earlier	project	1050 bytes	✓			
	tags	0.55 bytes		✓		
	messages that: <ul style="list-style-type: none"> transfer more than 500 bytes of data <i>and</i> target a controller in the same chassis This memory is allocated only when the MSG instruction is enabled. To estimate, count the number of these messages that are enabled and/or cached at one time.	2000 bytes	✓			
6.x or earlier	base tags	24 bytes			✓	
	alias tags	16 bytes			✓	
	produced and consumed tags	Data type	Bytes per tag			
		DINT	4	12 bytes	✓	
		REAL	4	12 bytes	✓	
				3 x bytes per tag	✓	
				3 x bytes per tag	✓	
			3 x bytes per tag	✓		
		3 x bytes per tag	✓			
6.x	routines	68 bytes			✓	
5.x or earlier	routines	116 bytes			✓	

For additional information on how the controller organizes its memory, see Knowledge base document 13964. To access Rockwell Automation's Knowledge base, go to www.ab.com. Select *Support*.

www.rockwellautomation.com

Power, Control and Information Solutions Headquarters

Americas: Rockwell Automation, 1201 South Second Street, Milwaukee, WI 53204-2496 USA, Tel: (1) 414.382.2000, Fax: (1) 414.382.4444

Europe/Middle East/Africa: Rockwell Automation, Vorstlaan/Boulevard du Souverain 36, 1170 Brussels, Belgium, Tel: (32) 2 663 0600, Fax: (32) 2 663 0640

Asia Pacific: Rockwell Automation, Level 14, Core F, Cyberport 3, 100 Cyberport Road, Hong Kong, Tel: (852) 2887 4788, Fax: (852) 2508 1846

Publication 20D-RN003A-EN-P - October 2002

PN 315854

© 2002 Rockwell International Corporation. Printed in the U.S.A.