

ControlLogix® Controller Revision 11

Cat. No. 1756-L1, -L1M1, -L1M2, -L1M3, -L55, -L55M12, -L55M13, -L55M14, -L55M16, -L55M22, -L55M23, -L55M24, -L63

ATTENTION

If you have a 1756-L63 controller, *do not* edit its ladder logic routines while online. Online edits could cause serious injury to personnel or damage to equipment.

To edit the ladder logic of a 1756-L63 controller while online, first complete the following actions:

1. Update your RSLogix 5000 software to revision 11.11 or later.
2. While *offline*, open the RSLogix 5000 project for the controller.
3. Save the project.
4. Download the project to the controller.

If you perform an online edit with revision 10.00, 11.00, 11.01, or 11.10 of RSLogix 5000 software, unpredictable controller operation could occur. This may include, but is not limited to:

- watchdog time of a task expires (major fault type 6, code 1)
- controller failure (solid red OK LED)

IMPORTANT

If you have a 1756-L55 controller, you must install a memory board. For more information, see the *ControlLogix Controller and Memory Board Installation Instructions*, publication 1756-IN101.

When to Use These Release Notes

These release notes correspond to the following revisions of the ControlLogix family of controllers:

Controller:	Catalog number:	Revision:
ControlLogix®5550	1756-L1, -L1Mx	11.35 or later
ControlLogix®5555	1756-L55, -L55Mxx	11.32 or later
ControlLogix®5563	1756-L63	11.27 or later

Compatible Revisions

To use this controller revision, update your system as follows:

Update this:	To this revision or later:
RSLinx® software	2.31
RSLogix™ 5000 software	11.11
RSNetWorx™ for ControlNet™ software	3.23
RSNetWorx for DeviceNet™ software	3.21
1756-M02AE module	5.5
1756-M08SE module	11.7
1756-M16SE module	11.7

What Is In These Release Notes

These release notes provide the following information:

For information about:	See this section:	On this page:
preliminary actions to take before you use this revision	Before You Update Your System	3
new features for all ControlLogix controllers	Common Enhancements	4
new features in ControlLogix5563 controllers	ControlLogix5563 Enhancements	5
changes to existing features in all ControlLogix controllers	Common Changes	5
restrictions that <i>no longer</i> apply to any ControlLogix controller	Common Corrected Anomalies	8
restrictions that <i>no longer</i> apply to ControlLogix5550 controllers	ControlLogix5550 Corrected Anomalies	12
restrictions that <i>no longer</i> apply to ControlLogix5555 controllers	ControlLogix5555 Corrected Anomalies	12
restrictions that <i>no longer</i> apply to ControlLogix5563 controllers	ControlLogix5563 Corrected Anomalies	13
restrictions for all ControlLogix controllers	Common Restrictions	14
restrictions for ControlLogix5555 controllers	ControlLogix5555 Restrictions	16
additional memory required to update to this revision	Additional Memory Requirements	17

Before You Update Your System

Before you update your controller or RSLogix 5000 software to this revision, do the following preliminary actions:

If:	Then:
Your controller is connected to a DH-485 network.	Disconnect it from the DH-485 network <i>before</i> you update the firmware of the controller. If you update the firmware of a controller while it is connected to a DH-485 network, communication on the network may stop.
You have a 1756-L55M23 or -L55M24 controller.	<p>See if all three of these conditions apply to the controller:</p> <ul style="list-style-type: none"> • Is the firmware revision of the controller 9.x or earlier? • Does the nonvolatile memory of the controller contain a project? • Is the <i>Load Image</i> property of the nonvolatile memory set to <i>On Power Up</i> or <i>On Corrupt Memory</i>? <p>If you answered yes to <i>all</i> of the questions, do the following <i>before</i> you update the firmware of the controller:</p> <ol style="list-style-type: none"> 1. In the <i>Load Image</i> drop-down list, select <i>User Initiated</i>. 2. Store the project to the nonvolatile memory of the controller. <p>Other Load Image selections cause the update of the controller to fail. (You are able to successfully update the controller the second time.)</p>
Your controller is close to its limits of memory.	<p>This revision <i>may</i> require more memory than previous revisions. Before you upgrade to this revision, do the following:</p> <ol style="list-style-type: none"> 1. Check the amount of unused memory that you have in the controller. To determine your unused memory, see either of the following documents: <ul style="list-style-type: none"> • Knowledgebase document 13964. To access Rockwell Automation's Knowledgebase, go to www.ab.com. Select <i>Support</i>. • <i>Logix5000 Controllers Common Procedures</i>, publication 1756-PM001E or later 2. If your controller is close to its limits of memory, see "Additional Memory Requirements" on page 17 to determine how much additional memory you require. <p>To upgrade to this revision, you may have to add an expansion memory card to the controller or use a larger memory card.</p>

Common Enhancements

Previous Enhancements

Previous revisions of ControlLogix controllers (ControlLogix5550, ControlLogix5553, ControlLogix5555, and ControlLogix5563) contained the following new features:

Enhancement:	Description:								
Sequential Function Chart Programming Language	<p>A sequential function chart (SFC) is similar to a flowchart of your process. It defines the steps or states through which your system progresses. Use the SFC to:</p> <ul style="list-style-type: none"> organize the functional specification for your system program and control your system as a series of steps and transitions <p>A sequential function chart can contain these elements:</p> <ul style="list-style-type: none"> steps transitions actions stops text boxes 								
New Instructions For Use with a Sequential Function Chart (SFC)	<table border="1"> <thead> <tr> <th>This instruction:</th> <th>Lets you:</th> </tr> </thead> <tbody> <tr> <td>EOT</td> <td>Set the state of a transition in an SFC to true or false</td> </tr> <tr> <td>SFP</td> <td>Pause an executing SFC</td> </tr> <tr> <td>SFR</td> <td>Reset the execution of an SFC to a different step or stop</td> </tr> </tbody> </table>	This instruction:	Lets you:	EOT	Set the state of a transition in an SFC to true or false	SFP	Pause an executing SFC	SFR	Reset the execution of an SFC to a different step or stop
	This instruction:	Lets you:							
	EOT	Set the state of a transition in an SFC to true or false							
SFP	Pause an executing SFC								
SFR	Reset the execution of an SFC to a different step or stop								
Structured Text Programming Language	<p>Structured text is a textual programming language that uses statements to define what to execute. Structured text can contain these components:</p> <ul style="list-style-type: none"> assignments expressions instructions constructs comments <p>You can either program structured text as a routine or embed the structured text within a sequential function chart</p>								
Online Editing of Function Block Routines	<p>This revision lets you edit function block routines (diagrams) while online with the controller.</p> <ul style="list-style-type: none"> Online edits include changes to logic, sheet names, pin visibility, block locations, etc. You edit a function block routine the way you edit a ladder routine: start a pending edit, accept the edit, test the edit, and finally assemble the edit. 								
1756-M16SE Module	You can use a ControlLogix controller and a 1756-M16SE motion module to control up to 16 axis on a SERCOS ring.								
More SERCOS Drives	<p>You can use a ControlLogix controller and a 1756-M08SE or 1756-M16SE motion module to control the following drives:</p> <ul style="list-style-type: none"> Kinetix 6000 SERCOS Drive 8720MC SERCOS Drive 								

ControlLogix5563 Enhancements

Previous Enhancements

A previous revision of ControlLogix5563 controllers contained the following new features:

Enhancement:	Description:
Nonvolatile Memory Storage	This revision lets you store a project in nonvolatile memory. For nonvolatile memory, install a 1784-CF64 Industrial CompactFlash card into the ControlLogix5563 controller.

Common Changes

Previous Changes

Previous revisions of ControlLogix controllers (ControlLogix5550, ControlLogix5553, ControlLogix5555, and ControlLogix5563) contained the following changes:

Change:	Description:
SIZE Instruction Lets You Specify an Array Tag	The source for a SIZE instruction can now be an array tag. You no longer have to specify the first element in the array.
PLC5 Typed Read Message Errors If Destination Is Too Small	<p>In a Message (MSG) instruction that is configured for <i>PLC5 Typed Read</i>, the instruction no longer executes if the Destination is too small for the Source data. If this occurs, the instruction sets the ER bit.</p> <p>If a MSG instruction is configured for <i>PLC5 Typed Read</i> and the data type of the Source does not match the data type of the Destination, the instruction converts the Source to the data type of the Destination. For example, if the data type of the Source is INTs and the data type of the Destination is DINTs, the instruction converts the INTs to DINTs. In this example, the Destination requires one DINT element for each INT of the Source data.</p> <p>In previous revisions, if a data conversion occurred but the Destination was too small, data beyond the Destination was overwritten. This may have caused the controller to fail during a download or online edit operation.</p>

Change:	Description:																									
REAL Data Type Shows an Extra Digit of Precision	<p>The REAL data type now shows a 32-bit (4-byte) IEEE floating-point value with the following range:</p> <ul style="list-style-type: none"> • $-3.40282347E^{-38}$ to $-1.17549435E^{-38}$ (negative values) • 0 • $1.17549435E^{-38}$ to $3.40282347E^{-38}$ (positive values) <p>The REAL data type also stores \pminfinity, \pmNAN, and -IND, but the software display differs based on the display format.</p> <table border="1"> <thead> <tr> <th>Display Format:</th> <th>Equivalent:</th> <th>Software Display:</th> </tr> </thead> <tbody> <tr> <td rowspan="5">Real</td> <td>+infinite</td> <td>1.\$</td> </tr> <tr> <td>- infinite</td> <td>-1.\$</td> </tr> <tr> <td>+NAN</td> <td>1.#QNAN</td> </tr> <tr> <td>-NAN</td> <td>-1.#QNAN</td> </tr> <tr> <td>-indefinite</td> <td>-1.#IND</td> </tr> <tr> <td rowspan="5">Exponential</td> <td>+infinite</td> <td>1.#INF000e+000</td> </tr> <tr> <td>- infinite</td> <td>-1.#INF000e+000</td> </tr> <tr> <td>+NAN</td> <td>1.#QNAN00e+000</td> </tr> <tr> <td>-NAN</td> <td>-1.#QNAN00e+000</td> </tr> <tr> <td>-indefinite</td> <td>-1.#IND0000e+000</td> </tr> </tbody> </table> <p>The software also stores and displays the IEEE subnormal range:</p> <ul style="list-style-type: none"> • $-1.17549421E^{-38}$ to $-1.40129846E^{-45}$ (negative values) • $1.40129846E^{-45}$ to $1.17549421E^{-38}$ (positive values) 	Display Format:	Equivalent:	Software Display:	Real	+infinite	1.\$	- infinite	-1.\$	+NAN	1.#QNAN	-NAN	-1.#QNAN	-indefinite	-1.#IND	Exponential	+infinite	1.#INF000e+000	- infinite	-1.#INF000e+000	+NAN	1.#QNAN00e+000	-NAN	-1.#QNAN00e+000	-indefinite	-1.#IND0000e+000
Display Format:	Equivalent:	Software Display:																								
Real	+infinite	1.\$																								
	- infinite	-1.\$																								
	+NAN	1.#QNAN																								
	-NAN	-1.#QNAN																								
	-indefinite	-1.#IND																								
Exponential	+infinite	1.#INF000e+000																								
	- infinite	-1.#INF000e+000																								
	+NAN	1.#QNAN00e+000																								
	-NAN	-1.#QNAN00e+000																								
	-indefinite	-1.#IND0000e+000																								

Change:	Description:	
PIDE_AUTOTUNE Structure Contains New Status Bits	When you use the PIDE Auto Tune feature, it is possible to set up a tuning environment in which the auto tune procedure successfully completes but the results are unusable. To provide an indication that this occurred, the PIDE_AUTOTUNE structure includes new members. You still have the option of accepting the auto tune values.	
To see if:	Examine this member of the PIDE_AUTOTUNE structure:	Explanation:
Observed PV change was too small	PVChangeTooSmall	<p>The PV change seen as a result of the CV step change was very small.</p> <ul style="list-style-type: none"> Filter your PV to eliminate excessive noise, which could have caused the autotuner to mistake a noise spike for an actual PV response. Make sure that the PIDE instruction is executing at an appropriate rate for your process. For example, if your process is a slow temperature loop, run your PIDE instruction in a slow (0.5 sec to 2 sec) periodic task. An execution rate that is too fast can cause the autotuner to mistake a noise spike right after the autotuner starts for an actual PV response.
Step size is too small	StepSizeTooSmall	The CV step size that you configured for the autotuner was very small. You might get better results if you autotune the loop again using a larger step size.
Process gain is too large	GainTooLarge	The autotuner identified your process as having a very large process gain. In other words, a small step change in CV output caused a very large change in PV. Make sure that your control actuator is properly sized for this application.
Process gain is too small	GainTooSmall	<p>The autotuner identified your process as having a very small process gain. In other words, a step change in CV output caused only a very small change in PV. To get better results:</p> <ul style="list-style-type: none"> Filter your PV to eliminate excessive noise, which could have caused the autotuner to mistake a noise spike for an actual PV response. Make sure that the PIDE instruction is executing at an appropriate rate for your process. For example, if your process is a slow temperature loop, run your PIDE instruction in a slow (0.5 sec to 2 sec) periodic task. An execution rate that is too fast can cause the autotuner to mistake a noise spike right after the autotuner starts for an actual PV response. Make sure that your control actuator is properly sized for this application.
Dead time is too long	LongDeadTime	The autotuner identified your process as having a long deadtime. In other words, it takes a long time between when the output of the loop changes and the PV starts to respond as a result of that change. This is often a result of having the sensor for your PV physically located far away from your actuator controlling the process. The autotuner will suggest a set of tuning constants, but standard PID control may have a difficult time controlling this process effectively.

You can also examine the bits of the AtuneStatus member for the same information:

For this member:	Examine this bit of the AtuneStatus member:
PVChangeTooSmall	27
StepSizeTooSmall	28
GainTooLarge	29
GainTooSmall	30
LongDeadTime	31

Change:	Description:
Use the Same Tag in Multiple IREFs and OREFs	<p>You can use the same tag in multiple IREFs and an OREF in the same routine. Because the values of tags in IREFs are latched every scan through the routine, all IREFs will use the same value, even if an OREF obtains a different tag value during execution of the routine. In this example, if tagA has a value of 25.4 when the routine starts executing this scan, and Block_01 changes the value of tagA to 50.9, the second IREF wired into Block_02 will still use a value of 25.4 when Block_02 executes this scan. The new tagA value of 50.9 will not be used by any IREFs in this routine until the start of the next scan.</p>

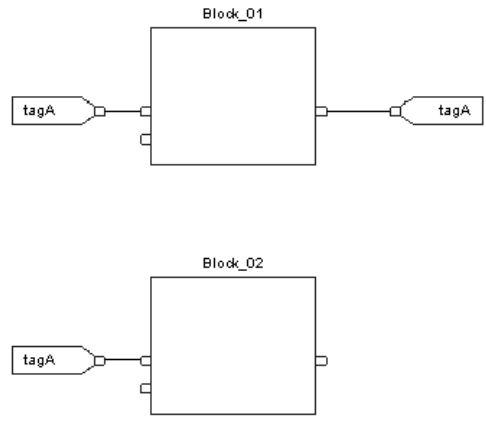

Common Corrected Anomalies

ControlLogix5550 Rev 11.34
ControlLogix5555 Rev 11.32
ControlLogix5563 Rev 11.25

Corrected anomaly:	Description:
Resetting an SFC Corrupted a Simultaneous Branch	<p>If you reset a sequential function chart (using an SFR instruction) while it was executing the next to last step of a path of a simultaneous branch, that path might have become corrupted. When the simultaneous branch was executed again, the controller might have experienced a non-recoverable fault (solid red OK LED) and cleared the project from its memory.</p> <p style="text-align: right;">Logix00038637</p>
Controller Could Not Connect to a Toledo Weigh Scale Over a ControlNet Network	<p>The controller was unable to establish a connection with a Toledo weigh scale over a ControlNet network.</p> <ul style="list-style-type: none"> • To communicate with the weigh scale, the I/O configuration of the project used the Generic ControlNet Module type. • If the input or output assembly instance = 255, the controller incorrectly encoded the value (16-bit instead of 8-bit). This prevented the controller from connecting to the weigh scale. • RSLogix 5000 software returned a module fault code of 16#0315. <p style="text-align: right;">Logix00039263</p>

Corrected anomaly:	Description:
Unconnected Messages Over an EtherNet/IP Network Produced a Non-Recoverable Fault	<p>Under the following combination of circumstances, a Message (MSG) instruction might have produced a non-recoverable fault (solid red OK LED):</p> <ul style="list-style-type: none"> • The MSG was configured as a PLC2, PLC3, PLC5, or SLC type message. • Communication was over an EtherNet/IP network. • The destination device was <i>not</i> present. <p>When the controller experiences a non-recoverable fault, it clears the project from memory. Logix00039233</p>
S-Curve Move Produced a Non-Recoverable Fault	<p>Under the following <i>combination</i> of circumstances, an S-Curve move profile produced a non-recoverable fault (solid red OK LED):</p> <ul style="list-style-type: none"> • Motion Axis Move (MAM) instruction or Motion Change Dynamics (MCD) instruction with an S-Curve profile • certain parameters (e.g., Speed operand = 0) <p>When the controller experiences a non-recoverable fault, it clears the project from memory. Logix00039272</p>
IP bit of an MAS Instruction Remained Set	<p>Execution of the following <i>sequence</i> of motion instructions might have prevented the IP bit of a Motion Axis Stop (MAS) instruction from turning off:</p> <ol style="list-style-type: none"> 1. Motion Axis Move (MAM) instruction with an S-Curve profile 2. Motion Change Dynamics (MCD) instruction with the Speed operand = 0 3. Motion Axis Stop (MAS) instruction with the Stop Type operand = Move <p>Logix00039272</p>

Previous Corrected Anomalies

Previous revisions of ControlLogix controllers (ControlLogix5550, ControlLogix5553, ControlLogix5555, and ControlLogix5563) corrected the following anomalies:

Corrected anomaly:	Description:						
Product Service Advisory— Power Disruptions Cleared Memory	<p>Important: This revision corrects the following anomaly only if your controller is currently at 11.x firmware. Exception: It also corrects the anomaly in the 1756-L63 controller, firmware revisions 10.x and later.</p> <p>If power to the controller turned on and then turned off again in less than a second, the controller might have cleared the project from its memory.</p> <ul style="list-style-type: none"> • If the controller did not have enough time to complete a critical portion of the power-up sequence (less than 1 second), the controller typically cleared its memory. • This might have occurred during brownouts or other situations where power to the controller fluctuated for a short duration. 						
Load from Nonvolatile Memory Produced Faults	<p>If a project <i>automatically</i> loaded from the nonvolatile memory of a controller, a fault might have occurred.</p> <table border="1" data-bbox="599 953 1463 1413"> <thead> <tr> <th data-bbox="607 961 753 989">If the project:</th> <th data-bbox="813 961 873 989">Then:</th> </tr> </thead> <tbody> <tr> <td data-bbox="607 1003 776 1066">contained motion axes</td> <td data-bbox="813 1003 1463 1255"> <p>A fault was more likely to occur. The following faults might have occurred:</p> <ul style="list-style-type: none"> • non-recoverable fault (solid red OK LED). This caused the controller to clear the project from its memory. • motion group fault. The controller failed to become the CST master. This caused the motion group to fault because there was no CST master in the chassis. </td> </tr> <tr> <td data-bbox="607 1270 753 1333"><i>did not</i> contain motion axes</td> <td data-bbox="813 1270 1463 1413"> <p>A fault was still possible, though less likely. The following fault might have occurred:</p> <ul style="list-style-type: none"> • non-recoverable fault (solid red OK LED). This caused the controller to clear the project from its memory. </td> </tr> </tbody> </table>	If the project:	Then:	contained motion axes	<p>A fault was more likely to occur. The following faults might have occurred:</p> <ul style="list-style-type: none"> • non-recoverable fault (solid red OK LED). This caused the controller to clear the project from its memory. • motion group fault. The controller failed to become the CST master. This caused the motion group to fault because there was no CST master in the chassis. 	<i>did not</i> contain motion axes	<p>A fault was still possible, though less likely. The following fault might have occurred:</p> <ul style="list-style-type: none"> • non-recoverable fault (solid red OK LED). This caused the controller to clear the project from its memory.
If the project:	Then:						
contained motion axes	<p>A fault was more likely to occur. The following faults might have occurred:</p> <ul style="list-style-type: none"> • non-recoverable fault (solid red OK LED). This caused the controller to clear the project from its memory. • motion group fault. The controller failed to become the CST master. This caused the motion group to fault because there was no CST master in the chassis. 						
<i>did not</i> contain motion axes	<p>A fault was still possible, though less likely. The following fault might have occurred:</p> <ul style="list-style-type: none"> • non-recoverable fault (solid red OK LED). This caused the controller to clear the project from its memory. 						
Removing a Controller as the CST Master Disables All Axes	<p>A project automatically loads from nonvolatile memory only if you configure it to do so. You can configure a project to automatically load under one of the following circumstances:</p> <ul style="list-style-type: none"> • during power-up • when the memory of the controller is empty <p>If you remove a controller as the Coordinated System Time (CST) master while online, all axes are disabled. This includes axes that are consuming axis data from another controller.</p> <p>In <i>previous</i> revisions, removing a controller as the CST master while online could have produced unexpected motion in axes controlled by other controllers in another chassis consuming axis data via SynchLink. The unexpected motion could have occurred on any axis that was geared or cammed to an axis that was consuming data via SynchLink from the controller that was the CST master.</p>						

Corrected anomaly:	Description:														
Online Edit of Tags Might Have Caused Communication Failure	<p>If you deleted an unused tag while online, you might have lost communication with the controller. RSLinx showed a Red X over the controller and you were unable to communicate with the controller through either the serial port or another communication module.</p> <p>The communication failure could have occurred immediately after you deleted the tag or later on in the execution of the project. A power cycle would temporarily clear the problem.</p>														
Size of the ASCII Buffer <i>No Longer</i> Limited to 255 Characters	You can set the size of the ASCII buffer of the serial port to any number of characters up to 65,536 characters. In previous revisions, a setting larger than 255 characters caused ABL instructions to miss the termination character and set status bits to erroneous values.														
AXIS_SERVO Data Type Was Improperly Scaled	<p>This revision corrects scaling errors for members (attributes) that provided <i>Real Time Axis Information</i> for a servo drive.</p> <ul style="list-style-type: none"> • The changes apply only to axis tags that used the AXIS_SERVO data type. • They <i>do not</i> apply to SERCOS axes, which use the AXIS_SERVO_DRIVE data type. <p>Revision 10.x improperly scaled the following members (attributes) of axis tags that used the AXIS_SERVO data type:</p> <table border="1"> <thead> <tr> <th>This member:</th> <th>Was scaled:</th> </tr> </thead> <tbody> <tr> <td>PositionIntegratorError</td> <td>20% too small</td> </tr> <tr> <td>VelocityCommand</td> <td>25% too large</td> </tr> <tr> <td>VelocityFeedback</td> <td>25% too large</td> </tr> <tr> <td>VelocityError</td> <td>25% too large</td> </tr> <tr> <td>AccelerationCommand</td> <td>56.25% too large</td> </tr> <tr> <td>AccelerationFeedback</td> <td>56.25% too large</td> </tr> </tbody> </table> <p>Because of the changes, you may have to update some parameters of your configuration.</p>	This member:	Was scaled:	PositionIntegratorError	20% too small	VelocityCommand	25% too large	VelocityFeedback	25% too large	VelocityError	25% too large	AccelerationCommand	56.25% too large	AccelerationFeedback	56.25% too large
This member:	Was scaled:														
PositionIntegratorError	20% too small														
VelocityCommand	25% too large														
VelocityFeedback	25% too large														
VelocityError	25% too large														
AccelerationCommand	56.25% too large														
AccelerationFeedback	56.25% too large														
Axis Data Types Used Incorrect Conversion Constant	<p>If you are updating your controller from revision 9.x or 10.x, you may have to change parameters that rely on the <i>Conversion Constant</i> attribute of an axis. Revision 9.x and 10.x of the firmware incorrectly used the slave axis when applying the <i>Conversion Constant</i> to the following members (attributes) of an axis:</p> <ul style="list-style-type: none"> • MasterOffset, • StrobeMasterOffset, • StartMasterOffset <p>This revision correctly uses the master axis when applying the <i>Conversion Constant</i>.</p>														
Failure to Write to Tags Via OPC/DDE	In the R11 firmware revisions prior to this revision, you could not write to a tag that was an alias for the tag of an I/O module. Neither tag would accept the write but the controller would not report a failure. For example, the failure to write occurred when another software application attempted to write to an alias tag via OPC/DDE communications.														
Deleting a Tag Online Caused Slow Communications or Controller Failure	<p>If you deleted a tag while online with the controller either of the following might have occurred:</p> <ul style="list-style-type: none"> • communications would slow down • the controller would fail (solid red OK LED) 														
Controller Occasionally Failed a Parity Check	This revision lets the controller recover from some parity errors without user intervention.														

Corrected anomaly:	Description:
Automatic Reset of an SFC Produced Erroneous Instruction Execution	<p>If you chose the <i>Automatic Reset</i> option for your SFCs, some instructions would execute incorrectly when executed directly or indirectly by an SFC:</p> <ul style="list-style-type: none"> • JSR/RET instruction pair produced a major fault. • FFL, FFU, LFL, LFU instructions caused the controller to fail (solid red OK LED).
SQO Instruction Failed to Execute a Prescan	If you chose the <i>Restart at most recently executed step</i> option for your SFCs, an SQO instruction would not execute a prescan when executed directly or indirectly by an SFC.
BTD Instruction Caused Controller Failure	If an SFC directly or indirectly executed a BTD instruction and the Length was greater than 31, the controller would fail (solid red OK LED).
SFC Alarming Failed to Stay Enabled or Disabled	In a step of an SFC, the <i>AlarmEnable</i> setting might not stay at the state you set it if you change it while online. For example, if you checked the <i>AlarmEnable</i> check box while online, it might revert to the cleared state later in the execution of your project.
SCRV Instruction Caused Controller Failure	Under certain combinations of input parameters, an S-Curve (SCRV) instruction might have divided a value by zero. This would have caused the controller to fail (solid red OK LED).

ControlLogix5550 Corrected Anomalies *ControlLogix5550 Rev 11.35*

Corrected anomaly:	Description:
Use of a Third-Party OPC Server Produced a Non-Recoverable Fault	<p>If you monitored data using a third-party OPC server that by-passed RSLinx software, the controller might have experienced a non-recoverable fault (solid red OK LED) and cleared the project from its memory.</p> <p style="text-align: right;">Logix00037864</p>

ControlLogix5555 Corrected Anomalies *ControlLogix5555 Rev 11.32*

Corrected anomaly:	Description:
Use of a Third-Party OPC Server Produced a Non-Recoverable Fault	<p>If you monitored data using a third-party OPC server that by-passed RSLinx software, the controller might have experienced a non-recoverable fault (solid red OK LED) and cleared the project from its memory.</p> <p style="text-align: right;">Logix00037864</p>

ControlLogix5563 Corrected Anomalies *ControlLogix5563 Rev 11.27*

Corrected anomaly:	Description:
In an SFC, a Major Fault Due to an Instruction Produced a Non-Recoverable Fault	<p>Under the following <i>combination</i> of circumstances, a major fault produced a non-recoverable fault (solid red OK LED):</p> <ol style="list-style-type: none"> 1. A sequential function chart (SFC) executed an instruction that produced a major fault. The instruction could have been either: <ul style="list-style-type: none"> • embedded as structured text within the SFC • in a subroutine that the SFC called 2. A fault routine cleared the fault. <p>When the controller experiences a non-recoverable fault, it clears the project from memory. Lgx00039772</p>
During Postscan a RET Instruction Might Have Returned Unexpected Values	<p>During postscan, a Return (RET) instruction continued to pass return parameters. Under the following <i>combination</i> of circumstances, this might have produced unexpected values.</p> <ol style="list-style-type: none"> 1. In a sequential function chart (SFC), multiple elements called the same subroutine at the same time and went inactive at the same time (e.g., an action called a subroutine several times, several paths of a simultaneous branch called the same subroutine). 2. The subroutine manipulated tag values and returned the values to the SFC via a RET instruction. 3. The <i>SFC Execution—Last Scan of Active Steps</i> option = <i>Automatic Reset</i>. <p>With the Automatic Reset option, the controller postscans the logic and subroutines of an SFC action when the action goes from active to inactive.</p> <ul style="list-style-type: none"> • If the SFC calls the subroutine multiple times, the controller postscans the subroutine multiple times. • During postscan, the logic might not manipulate tag values. As a general rule, the postscan executes instructions as if all conditions are false. • Without the manipulation of the values, the RET instruction returned the same value during each postscan. The values were left over from the last normal scan of the subroutine. <p>With this revision, a RET instruction no longer passes return parameters during postscan. Lgx00040382</p>

ControlLogix5563 Rev 11.26

Corrected anomaly:	Description:
Use of a Third-Party OPC Server Produced a Non-Recoverable Fault	<p>If you monitored data using a third-party OPC server that by-passed RSLinx software, the controller might have experienced a non-recoverable fault (solid red OK LED) and cleared the project from its memory. Logix00037864</p>

Previous Corrected Anomalies

Previous revisions of ControlLogix5563 corrected the following anomalies:

Corrected anomaly:	Description:
Floating-Point Math Might Have Produced Unpredictable Controller Operation	<p>Product Service Advisory ACIG 2002-11-001</p> <p>If you have a ControlLogix5563 controller, unpredictable operation could have occurred under the following combination of conditions:</p> <ol style="list-style-type: none"> 1. Your controller contains a sequential function chart (SFC). 2. The SFC initiates a math operation (e.g., +, -, *, /) either as an expression in the SFC or in a routine that is called at some point in the execution of the SFC. 3. The math operation involves one or more tags that use the REAL data type. The tag or tags may be one of the values that are operated on (operand) or it may be the destination of the result. 4. The math operation produces an overflow, such as x/0. <p>All four conditions must have occurred to produce the unpredictable operation. The unpredictable operation may have included failure of the controller (solid red OK LED).</p>
Divide By Zero Failed to Produce a Minor Fault	<p>If you divided a floating-point value (REAL data type) by zero, the controller failed to log a minor fault for the overflow condition. The controller would correctly set the overflow bit (S:V).</p>

Common Restrictions

This revision of ControlLogix controllers (ControlLogix5550, ControlLogix5553, ControlLogix5555, and ControlLogix5563) has the following restrictions:

Restriction:	Description:
Array Subscript That Is Out of Range Produces Non-Recoverable Fault	<p>Under the following <i>combination</i> of circumstances, an array subscript produces a non-recoverable fault (solid red OK LED):</p> <ul style="list-style-type: none"> • A CMP, CPT, FAL, or FSC instruction operates on an array. • A tag identifies the subscript of the array (indirect address). • The indirect address uses an expression to calculate the value for the array subscript. • The indirect address produces a subscript that is too large for the array. (This produces a major fault.) • The controller contains a fault routine that tries to clear the major fault. <p>When the controller experiences a non-recoverable fault, it clears the project from memory.</p>

Logix00038663

Restriction:	Description:						
LDL2 Instruction Produces Inaccurate Coefficients or Controller Failure	<p>A Second-Order Lead Lag (LDL2) instruction may produce the following:</p> <ul style="list-style-type: none"> • inaccurate internal coefficients • controller failure (solid red OK LED) <p>This may occur under the following <i>combination</i> of circumstances:</p> <ul style="list-style-type: none"> • You initially set the following input parameters = 0: <ul style="list-style-type: none"> • WLead • WLag • ZetaLag • While the controller is in run mode, you change any of the following parameters: <ul style="list-style-type: none"> • WLead • WLag • ZetaLead • ZetaLag • Order <p>Instead of setting the input parameters = 0, set the input parameters as follows:</p> <table border="1" data-bbox="597 955 1479 1354"> <thead> <tr> <th data-bbox="597 955 808 997">If:</th> <th data-bbox="808 955 1479 997">Then set the input parameters as follows:</th> </tr> </thead> <tbody> <tr> <td data-bbox="597 997 808 1171">Order = 1</td> <td data-bbox="808 997 1479 1171"> WLead = 0.0000001/DeltaTime WLead = 0.0000001/DeltaTime ZetaLag = 0.05 </td> </tr> <tr> <td data-bbox="597 1171 808 1354">Order = 2</td> <td data-bbox="808 1171 1479 1354"> WLead = 0.00001/DeltaTime WLead = 0.00001/DeltaTime ZetaLag = 0.05 </td> </tr> </tbody> </table>	If:	Then set the input parameters as follows:	Order = 1	WLead = 0.0000001/DeltaTime WLead = 0.0000001/DeltaTime ZetaLag = 0.05	Order = 2	WLead = 0.00001/DeltaTime WLead = 0.00001/DeltaTime ZetaLag = 0.05
If:	Then set the input parameters as follows:						
Order = 1	WLead = 0.0000001/DeltaTime WLead = 0.0000001/DeltaTime ZetaLag = 0.05						
Order = 2	WLead = 0.00001/DeltaTime WLead = 0.00001/DeltaTime ZetaLag = 0.05						
Project May Fail to Download	<p>If you update the controller from firmware revision 10.x to this revision, the project may fail to download. This occurs if the project contains more than 250 connections:</p> <ul style="list-style-type: none"> • Firmware revisions 10.x erroneously let you exceed 250 connections. • This revision requires that the project stay within 250 connections. • If you created more than 250 connections while using firmware revision 10.x, the project will no longer download after you update it to this firmware revision. • If this occurs, reduce the number of connections. 						

ControlLogix5555 Restrictions

IMPORTANT

Do not use this revision of firmware in a redundant controller system (ControlLogix Redundancy system).

The 1756-L55M16 controller has the following restrictions:

Restriction:	Description:
3.5M Byte Limit of Tags	<p>You <i>cannot</i> download a project that has more than 3.5M bytes of tags to a 1756-L55M16 controller. During the download, RSLogix 5000 software indicates that the controller is out of memory.</p> <p>To stay within the 3.5M byte limit, take this precaution:</p> <ul style="list-style-type: none"> As you create tags, periodically download the project. If the project successfully downloads, then you know you are within the 3.5M byte limit.
Guidelines for the Size of Routines	<p>You <i>cannot</i> download a project that has very large routines. During the download, RSLogix 5000 software indicates that the controller is out of memory. (While online, you may be able to create a very large routine, but once offline you will be unable to download the project.)</p> <p>To avoid creating routines that are too large, take these precautions:</p> <ul style="list-style-type: none"> Limit the number of rungs in a routine to less than 2500. (Use a series of smaller routines.) If you are entering a large number of rungs in a routine, do this offline. As you enter rungs, periodically download the project. If the project successfully downloads, then your routines are within limits.

Additional Memory Requirements

Revision 11.x *may* require more memory than previous revisions (e.g., 8.x, 10.x). To estimate the additional memory that your project *may* require, use the following table:

If you have this firmware revision (add <i>all</i> that apply):	Then add the following memory requirements to your project:			Which comes from this type of memory:		
	Component	Increase per instance	I/O (base)	Data and Logic (expansion)		
10.x or earlier	project for a ControlLogix5555 controller	1200 bytes		✓		
	project for a ControlLogix5563 controller	1200 bytes	✓			
	programs	12 bytes		✓		
	routines	16 bytes		✓		
9.x or earlier	project for a ControlLogix5550 controller	1200 bytes	✓			
	tag that uses the MESSAGE data type	376 bytes		✓		
8.x or 9.x	produced or consumed axis	(-21.6K bytes)	✓			
	axis that <i>is not</i> produced or consumed	(-21.6K bytes)		✓		
8.x or earlier	output cam execution targets	5,404 bytes		✓		
	motion group	32 bytes		✓		
7.x or earlier	project	1050 bytes	✓			
	tags	0.55 bytes		✓		
	messages that: <ul style="list-style-type: none"> transfer more than 500 bytes of data and target a controller in the same chassis This memory is allocated only when the MSG instruction is enabled. To estimate, count the number of these messages that are enabled and/or cached at one time.	2000 bytes	✓			
6.x or earlier	base tags	24 bytes			✓	
	alias tags	16 bytes			✓	
	produced and consumed tags	Data type	Bytes per tag			
		DINT	4	12 bytes	✓	
		REAL	4	12 bytes	✓	
			3 x bytes per tag	✓		
		3 x bytes per tag	✓			
6.x	routines	68 bytes			✓	
5.x or earlier	routines	116 bytes			✓	

For additional information on how the controller organizes its memory, see Knowledgebase document 13964. To access Rockwell Automation's Knowledgebase, go to www.ab.com. Select *Support*.

Rockwell Automation Support

Rockwell Automation provides technical information on the web to assist you in using our products. At <http://support.rockwellautomation.com>, you can find technical manuals, a knowledge base of FAQs, technical and application notes, sample code and links to software service packs, and a MySupport feature that you can customize to make the best use of these tools.

For an additional level of technical phone support for installation, configuration and troubleshooting, we offer TechConnect Support programs. For more information, contact your local distributor or Rockwell Automation representative, or visit <http://support.rockwellautomation.com>.

Installation Assistance

If you experience a problem with a hardware module within the first 24 hours of installation, please review the information that's contained in this manual. You can also contact a special Customer Support number for initial help in getting your module up and running:

United States	1.440.646.3223 Monday – Friday, 8am – 5pm EST
Outside United States	Please contact your local Rockwell Automation representative for any technical support issues.

New Product Satisfaction Return

Rockwell tests all of our products to ensure that they are fully operational when shipped from the manufacturing facility. However, if your product is not functioning and needs to be returned:

United States	Contact your distributor. You must provide a Customer Support case number (see phone number above to obtain one) to your distributor in order to complete the return process.
Outside United States	Please contact your local Rockwell Automation representative for return procedure.

www.rockwellautomation.com

Power, Control and Information Solutions Headquarters

Americas: Rockwell Automation, 1201 South Second Street, Milwaukee, WI 53204-2496 USA, Tel: (1) 414.382.2000, Fax: (1) 414.382.4444

Europe/Middle East/Africa: Rockwell Automation, Vorstlaan/Boulevard du Souverain 36, 1170 Brussels, Belgium, Tel: (32) 2 663 0600, Fax: (32) 2 663 0640

Asia Pacific: Rockwell Automation, Level 14, Core F, Cyberport 3, 100 Cyberport Road, Hong Kong, Tel: (852) 2887 4788, Fax: (852) 2508 1846