



1336 SPIDER Firmware Release 3.001-4.xxx

This document summarizes firmware changes made to the *1336 SPIDER Adjustable Frequency AC Drive* (version 2.004). **Please place this document with your manual for future reference.**

Parameter Changes

Default Value Changes

Parameter Name	Number	Description of Change
[Speed Control]	77	Factory Default changed to "No Control."
[DC Hold Level]	13	Factory Default changed to "0%."
[Dig At Temp]	267	Factory Default changed to 120°.
[PI Max Error]	293	Factory Default changed to "Maximum Freq Forward."
[IR Drop Volts]	194	Factory Default changed to "Based on Drive Size," Minimum Value changed to "0.0 Volts." See additional change below.

Other Changes

Parameter Name	Number	Description of Change
[4-20mA Loss Sel]	150	Description clarified.
[Alarm Mask 1]	206	"Phase Loss" added at bit 12.
[Alarm Mask 2]	271	"Enc Cnt Set," "Enc Cnt Max," "Voltage Check" added.
[Control Select]	9	Economize mode description clarified.
[CRx Out Select]	158, 174-176	"Remote" selection added.
[Current Limit]	36	Description addition: Induction Motors Only Drive is protected internally for induction motor selection values up to 160%. Between 0 & 5 Hz the output current is reduced to protect the power unit. See Derating Guidelines table in User Manual for details.
[Drive Alarm 1]	60	"Phase Loss" added at bit 12.
[Drive Alarm 2]	269	"Enc Cnt Set," "Enc Cnt Max," "Voltage Check" added.
[Drive Status 2]	236	"PI Max Error" added at bit 14.
[Fault Alarms 2]	287	"Enc Cnt Set," "Enc Cnt Max," "Voltage Check" added.
[Fault Alarms]	173	"Phase Loss" added at bit 12.
[Fault Status 2]	286	"PI Max Error" added at bit 14.
[Flux Amps Ref]	192	Used in "Economize" mode . . .
[Input Mode]	241	Selection "4," 2WR-PWR DIP" added.
[IR Drop Volts]	194	Used in "Economize" mode . . .
[Language]	47	Language selections have been updated.
[Latched Alarms 1]	205	"Phase Loss" added at bit 12.
[Latched Alarms 2]	270	"Enc Cnt Set," "Enc Cnt Max," "Voltage Check" added.
[Maximum Freq]	19	Minimum value changes 10Hz.
[Maximum Voltage]	20	Description clarified.
[Min Bus Volts]	323	Factory Default corrected to "194/388/485 Volts."
[Motor Type]	41	Description addition: The current limit maximum is dependent on the [Drive Type] selection and internally limited for the "Induction" selection. Current limit values are listed in Appendix A (User Manual).
[Overload Amps]	38	Description clarified.
[Shear Pin Fault]	226	"Not Accel" selection added.
[Sync Loss Sel]	310	Description addition: Important: The motor must be connected to the drive when the sync loss function is enabled.
[TB5 Term 2x Sel]	242-247	"CB Precharge" selection added.

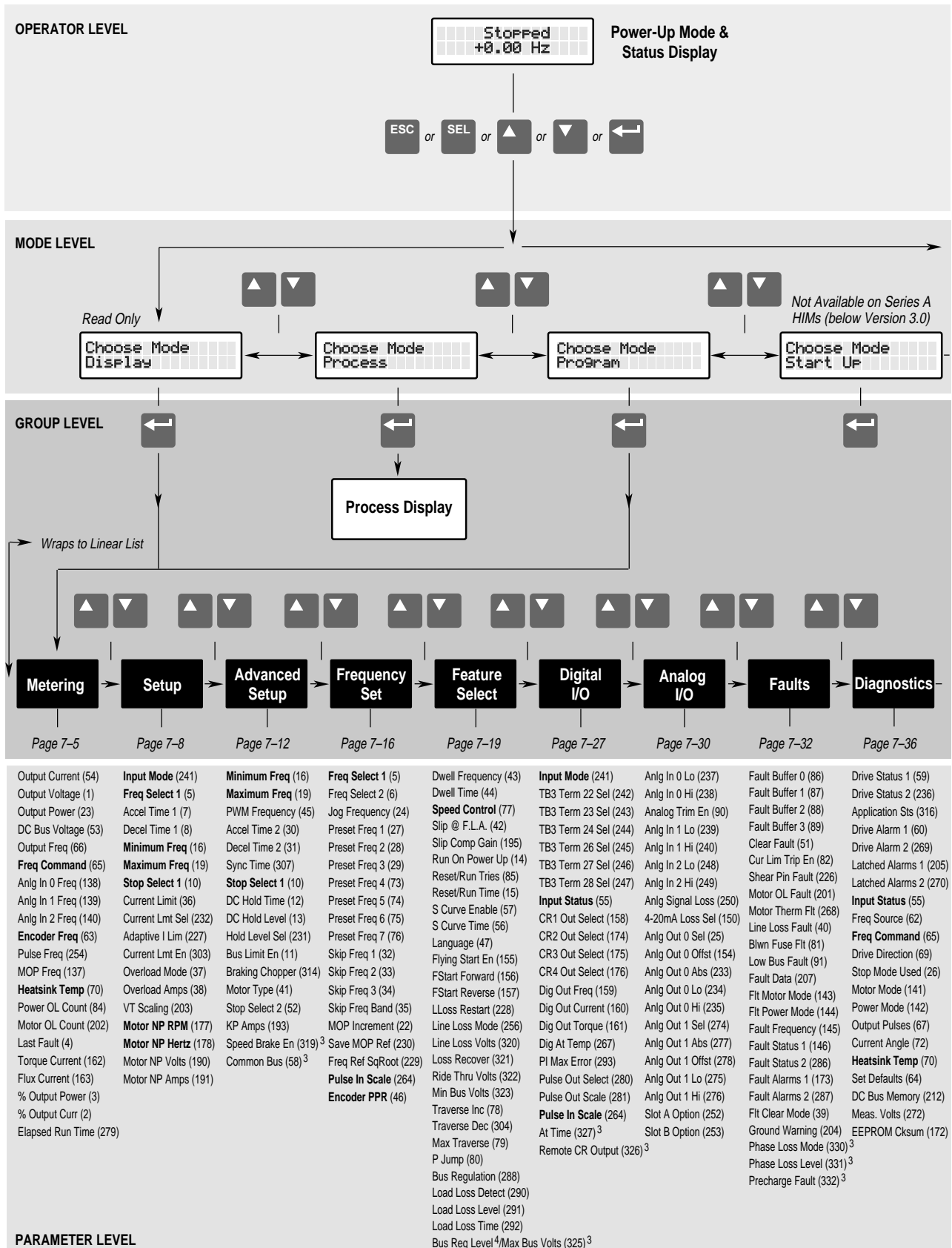

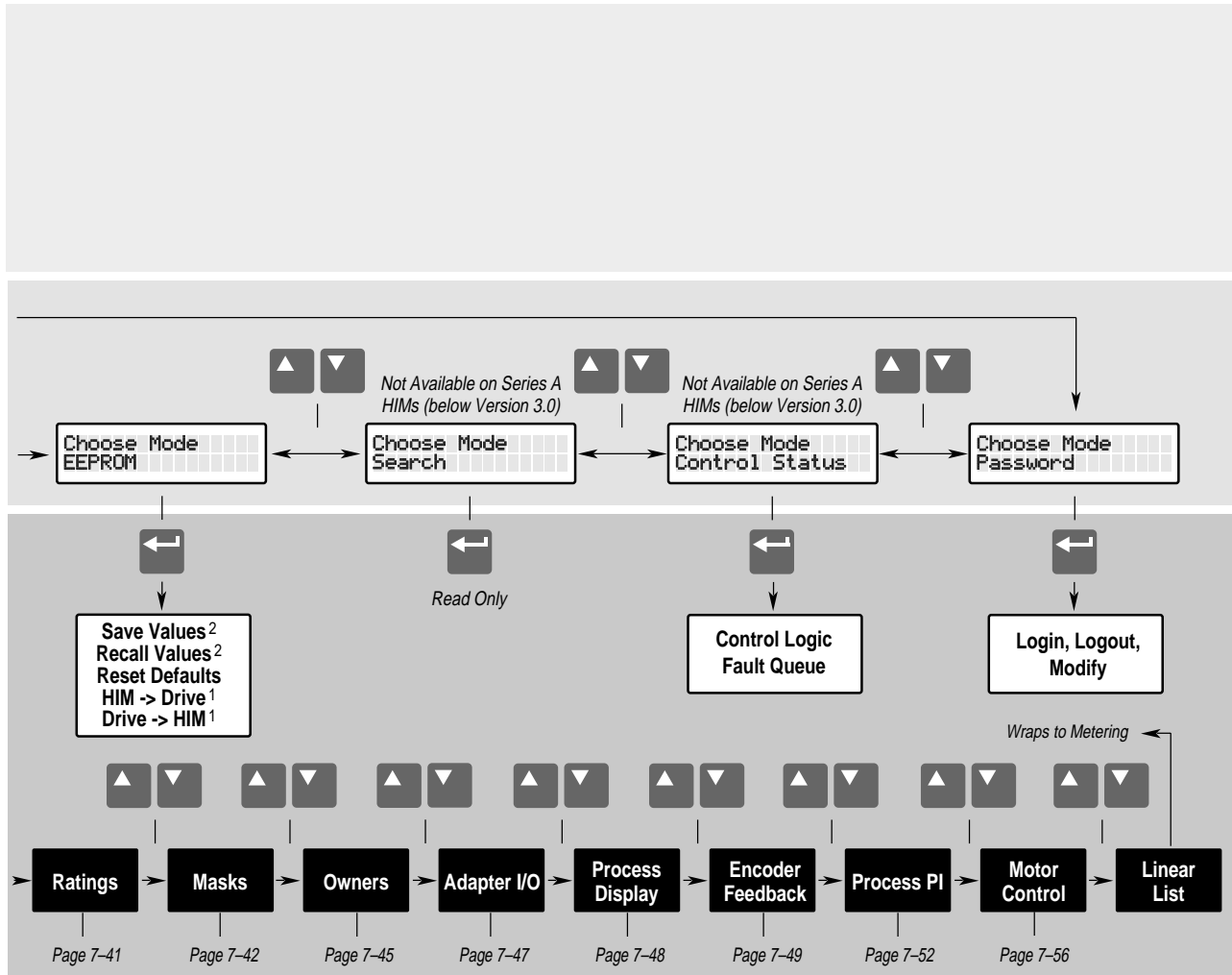

Rated Volts (147)	Direction Mask (94)	Stop Owner (102)	Data In A1 (111)	Process 1 Par (127)	Speed Control (77)	Speed Control (77)	Control Select (9)
Rated Amps (170)	Start Mask (95)	Direction Owner (103)	Data In A2 (112)	Process 1 Scale (128)	Encoder Type (152)	PI Config (213)	Flux Amps Ref (192)
Rated kW (171)	Jog Mask (96)	Start Owner (104)	Data In B1 (113)	Process 1 Txt 1 (129)	Encoder PPR (46)	PI Status (214)	IR Drop Volts (194)
Firmware Ver. (71)	Reference Mask (97)	Jog Owner (105)	Data In B2 (114)	Process 1 Txt 2 (130)	Maximum Speed (151)	PI Ref Select (215)	Flux Up Time (200)
Cntrl Board Rev (251)	Accel Mask (98)	Reference Owner (106)	Data In C1 (115)	Process 1 Txt 3 (131)	Motor Poles (153)	PI Fdbk Select (216)	Start Boost (48)
Rated CT Amps (148)	Decel Mask (99)	Accel Owner (107)	Data In C2 (116)	Process 1 Txt 4 (132)	Speed KI (165)	PI Reference (217)	Run Boost (83)
Rated CT kW (149)	Fault Mask (100)	Decel Owner (108)	Data In D1 (117)	Process 1 Txt 5 (133)	Speed KP* (164)	PI Feedback (218)	Boost Slope (169)
Rated VT Amps (198)	MOP Mask (101)	Fault Owner (109)	Data In D2 (118)	Process 1 Txt 6 (134)	Speed Error (166)	PI Error (219)	Break Voltage (50)
Rated VT kW (199)	Traverse Mask (305)	MOP Owner (110)	Data Out A1 (119)	Process 1 Txt 7 (135)	Speed Integral (167)	PI Output (220)	Break Frequency (49)
Drive Type (61)	Sync Mask (308)	Traverse Owner (306)	Data Out A2 (120)	Process 1 Txt 8 (136)	Speed Adder (168)	KI Process (221)	Base Voltage (18)
	Logic Mask (92)	Sync Owner (309)	Data Out B1 (121)	Process 2 Par (180)	Slip Adder (255)	KP Process (222)	Base Frequency (17)
	Local Mask (93)	Local Owner (179)	Data Out B2 (122)	Process 2 Scale (181)	Motor NP RPM (177)	PI Neg Limit (223)	Maximum Voltage (20)
	Alarm Mask 1 (206)		Data Out C1 (123)	Process 2 Txt 1 (182)	Motor NP Hertz (178)	PI Pos Limit (224)	Run/Accel Volts (317)
	Alarm Mask 2 (271)		Data Out C2 (124)	Process 2 Txt 2 (183)	Encoder Counts (283)	PI Preload (225)	Sync Loss Sel (310)
			Data Out D1 (125)	Process 2 Txt 3 (184)	Enc Count Scale (282)		Sync Loss Gain (311)
			Data Out D2 (126)	Process 2 Txt 4 (185)	Encoder Loss Sel (284)		Sync Loss Comp (313)
			Alt Type 2 Cmd (315)	Process 2 Txt 5 (186)	Encoder Freq (63)		Sync Loss Time (312)
				Process 2 Txt 6 (187)	Max Enc Counts (328) ³		PWM Comp Time (333) ⁴
				Process 2 Txt 7 (188)			Break Freq (334) ⁴
				Process 2 Txt 8 (189)			

¹ Series B & Up Handheld HIM Only
² Reserved for Future Use
³ Firmware Version 3.001 & later
⁴ Firmware Version 4.001 & later

Note: Parameters that appear in more than one group are shown in **Bold** – Parameter Numbers are shown in (parenthesis). An asterisk (*) indicates that the parameter was not functional at time of printing.

New Parameters

Advanced Setup

<p>[Speed Brake En]</p> <p>Enabling this feature allows faster deceleration by raising the flux in the motor and increasing the losses. Speed change braking is used in sensorless vector mode only and is effective for motors up to 20 HP.</p>	<p>Parameter Number Parameter Type Factory Default Units</p>	<p>319 Read and Write "Disabled" Display Drive "Disabled" 0 "Enabled" 1 DC injection braking during decel</p>
<p>[Common Bus]</p> <p>When enabled, internal precharge is disabled, allowing common bus operation. "CB Precharge" must be selected in [TB3 Term xx Sel].</p>	<p>Parameter Number Parameter Type Factory Default Units</p>	<p>58 Read and Write "Disabled" Display Drive "Disabled" 0 "Enabled" 1</p>

Feature Select

<p>[Bus Reg Level] – Firmware 4.001 & later [Max Bus Volts]</p> <p>Sets the limit that the drive DC bus voltage can rise before a fault occurs. When this parameter is set to the minimum value, the drive DC bus voltage is limited to 110% of nominal voltage. [Bus Limit En] must be "Enabled" for the drive to limit the bus voltage. This setting is used to move the trigger point for regulation above the turn-on point for dynamic brake or regeneration packages.</p>	<p>Parameter Number Parameter Type Display Units / Drive Units Factory Default Minimum Value Maximum Value</p>	<p>325 Read and Write 1 Volt / 4096 = Drive Rtd Volts 358/716/895 Volts 358/716/895 Volts 403/807/1009 Volts</p>
---	--	--

Digital I/O

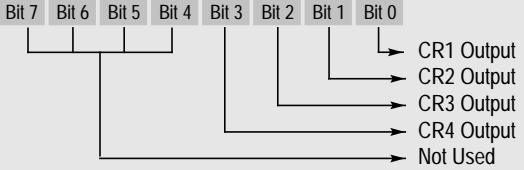
<p>[At Time]</p> <p>Sets the delay time for the activation of the CR1-4 relays. The relay is activated at Start + [At Time] seconds. This delay affects all relays.</p>	<p>Parameter Number Parameter Type Display Units / Units Factory Default Minimum Value Maximum Value</p>	<p>327 Read and Write 0.01 Second / Seconds x 100 0.00 Sec 0.00 Sec 360.00 Sec</p>
<p>[Remote CR Output]</p> <p>Individual bits control relay outputs when selected with [CR1-4 Out Select]. 1 = Energize Coil. This parameter is reset to the default on power-up.</p> <p><u>Example:</u> If [CR2 Out Select] is set to "Remote," bit 1 of this parameter will control CR2.</p> <p>A Status description (bit ENUM) is displayed on line 1 (except Series A HIMs below version 3.0).</p>	<p>Parameter Number Parameter Type Factory Default</p>	<p>326 Read and Write xxxx0000</p> 

Faults

[Phase Loss Mode]

Enables the function that detects a phase loss or the current rating has been exceeded in the drive if powered on single-phase line. A fault (F49) or alarm condition will occur if the DC bus ripple voltage exceeds the level in [Phase Loss Level].

Parameter Number	330
Parameter Type	Read and Write
Factory Default	"Disabled"
Units	Display Drive
	"Disabled" 0 No Fault Generated
	"Alarm" 1 Generates a Phase Loss Alarm
	"Fault" 2 Generated F49 Input Phase Fault

[Phase Loss Level]

Sets the DC bus ripple voltage above which a phase loss fault/alarm will occur. The sensitivity for detecting a blown fuse on a three-phase system can be increased by lowering the setting for this parameter.

Parameter Number	331
Parameter Type	Read and Write
Display Units / Drive Units	0.1 Volts / 4096 = Drive Rtd Volts
Factory Default	9.0/18.0/22.5 Volts
Minimum Value	5.1/10.1/12.7 Volts
Maximum Value	22.5/45.0/56.2 Volts

[Precharge Fault]

Enables or disables the Precharge Fault, which indicates insufficient DC bus charging 20 seconds after power-up.

Parameter Number	332
Parameter Type	Read and Write
Factory Default	"Disabled"
Units	Display Drive
	"Disabled" 0 No Fault Generated
	"Enabled" 1 Precharge Fault Generated

Motor Control

[PWM Comp Time] – Firmware 4.001 & later

This parameter does not function with the SPIDER drive.

Parameter Number	333
Parameter Type	Read and Write
Display Units / Drive Units	None
Factory Default	80
Minimum Value	20
Maximum Value	90

[Break Freq] – Firmware 4.001 & later

This parameter does not function with the SPIDER drive.

Parameter Number	334
Parameter Type	Read and Write
Display Units / Drive Units	0.01 Hertz / 32767 = Maximum Freq Forward
Factory Default	0 Hz
Minimum Value	0 Hz
Maximum Value	30 Hz

Linear List

[Stability Gain]

This parameter adjusts the gain of the torque component of current to adjust for possible current instability in certain motors caused by variations in design. Increasing this value to the correct setting for a particular motor will stabilize torque pulsations in the motor.

Important: Setting this value too high may cause additional instability. It should be set for the lowest value that eliminates the instability.

Parameter Number	324
Parameter Type	Read and Write
Display Units / Drive Units	None
Factory Default	0
Minimum Value	0
Maximum Value	16

[Bidir In Offset]

Trims the offset of the bi-directional inputs on LA6 & LA7 option cards. To provide an equal response to positive and negative signals, this parameter may need to be adjusted for each board. With no voltage on input 0, monitor [Anlg In 0 Freq] and adjust [Bidir In Offset] until it is zero.

Parameter Number	329
Parameter Type	Read and Write
Display Units / Drive Units	None
Factory Default	270
Minimum Value	0
Maximum Value	1024

New Fault

Name & Fault #	Description	Action
Input Phase Flt 49	The DC bus ripple has exceeded the value in [Phase Loss Level].	<ol style="list-style-type: none"> 1. If the drive is operated on single-phase, the load derating level has been exceeded. 2. Check incoming power for a missing phase/blown fuse.

Additional Changes

Page 3-4, 4-4

The following statement was added:
 “The 24 volt power supply is capable of supplying a total of 16 digital inputs.”

Page 6-2

The following was added before “Step 1.”

Assisted Start-Up

Keys	Description	The HIM Display will show . . .
Disconnect Load from Motor	For proper operation of the Autotune function, assure that the load is disconnected from the motor. Important: The Autotune routine is designed for use with standard induction motors only. It should not be used with synchronous motors.	
Reconnect load was added to Step 5.		
	<ol style="list-style-type: none"> 5. Start-up is complete. Remove all power, then reconnect load to motor. Check for proper operation. 	

Page A-1

The following specification was added to “Environment.”

Atmosphere

Important: Drive **must not** be installed in an area where the ambient atmosphere contains volatile or corrosive gas, vapors or dust. If the drive is not going to be installed for a period of time, it must be stored in an area where it will not be exposed to a corrosive atmosphere.

Page A-2

The “Total Harmonic Distortion” specification was added under “Electrical.”

Total Harmonic Distortion (THD): acc. IEEE519/EEN61800-3

The programmable limit was changed for “Current Limit Capability.”

Current Limit Capability: Proactive Current Limit programmable from 20% to peak current of rated output current. Independently programmable proportional and integral gain.

Page A-3

The Derating table was changed as follows:

Voltage Rating	Drive Catalog No.	Carrier Frequency kHz	Synch./Synch. Reluctance Motors				Induction Motors					DC Brake Current ³ A_{rms}	Dynamic Brake Current ^{4,5} A_{DC}/R_{min}
			F.L.A.			Current Limit ¹ Peak Current	F.L.A.			Current Limit ²			
			$T_a=50^\circ C$	$T_a=45^\circ C$	$T_a=40^\circ C$		$T_a=50^\circ C$	$T_a=45^\circ C$	$T_a=40^\circ C$	Peak Current	at 0 Hz		
200-240V	A022	2	9A	9A	9A	21.6A = 240%	9A	9A	9A	14.4A = 160%	160%	12.6	15A/25 Ohms
		4	9A	9A	9A		9A	9A	9A				
		8	9A	9A	9A		9A	9A	9A				
	A036	2	15A	15A	15A	36A = 240%	13.9A	15A	15A	24A = 160%	118%	21.0	15A/25 Ohms
		4	14A	15A	15A		13A	15A	15A				
		8	10A	12.5A	15A		11A	13.6A	15A				
	A060	2	30A	30A	30A	60A = 200%	24A	28.2A	30A	48A = 160%	101%	30.0	23A/16 Ohms
		4	25A	30A	30A		23A	26.5A	30A				
		8	18A	22A	26A		18A	23.8A	27A				
380-480V	B010	2	8.5A	9.9A	9.9A	9.9A = 100%	8.5A	9.9A*	9.9A*	9.9A = 100%	89%	7.0	10A/75 Ohms
		4	5.5A	6.4A	7.3A		5.5A	8.4A	9.9A*				
	B017	2	10.0A	11.5A	13.0A	16.5A = 127%	9.5A	11.6A	13A	16.5A = 127%	105%	9.1	14A/53 Ohms
		4	6.0A	7.2A	8.4A		6.0A	9.6A	11.1A				
	B033	2	17A	20A	23A	33A = 143%	16.8A	19.9A	23A	33A = 143%	101%	16.1	17A/43 Ohms
		4	10A	12A	14A		14A	16.5A	19A				

Shading indicates Drive [Rated Amps], “*” Indicates No Overload.

¹ For 20 seconds every 10 minutes. The maximum [Current Limit] setting is shown.

² The maximum [Current Limit] setting is shown. Normal Duty (ND) = 100%, 110% for 1 minute to 10 minutes, peak current for 3 seconds.

³ Note that parameter 13, [DC Hold Level] must NOT be set to 150%, but maximum as follows: (A022) 140%, (A036) 140%, (A060) 100%, (B010) 70%, (B017) 70%, (B033) 70%.

⁴ The dynamic braking current is only defined by the external resistor. There is no internal current control nor short circuit protection. Respective measures as bimetal relay, klaxon etc have to be taken externally.

⁵ See Chapter 2 in the User Manual for dynamic brake resistor wiring information and Appendix B for dimension information.

Page B-3

Add the following dynamic brake information.



ATTENTION: The drive does not offer protection for externally mounted brake resistors. A risk of fire exists if external braking resistors are not protected. External resistor packages must be self-protected from over temperature or the protective circuit (or equivalent) shown on page 8 must be supplied.

Typical External Brake Circuitry

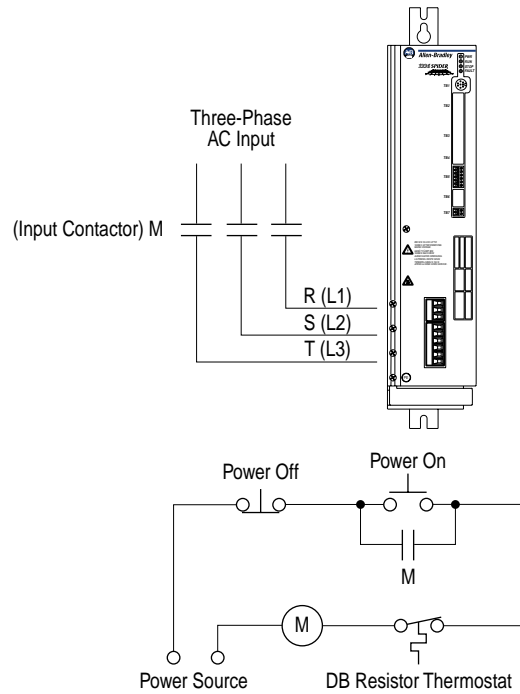

www.rockwellautomation.com

Power, Control and Information Solutions Headquarters

Americas: Rockwell Automation, 1201 South Second Street, Milwaukee, WI 53204-2496 USA, Tel: (1) 414.382.2000, Fax: (1) 414.382.4444

Europe/Middle East/Africa: Rockwell Automation, Vorstlaan/Boulevard du Souverain 36, 1170 Brussels, Belgium, Tel: (32) 2 663 0600, Fax: (32) 2 663 0640

Asia Pacific: Rockwell Automation, Level 14, Core F, Cyberport 3, 100 Cyberport Road, Hong Kong, Tel: (852) 2887 4788, Fax: (852) 2508 1846