

LISTEN.  
THINK.  
SOLVE.<sup>SM</sup>

# ARMORSTART<sup>®</sup> DISTRIBUTED MOTOR CONTROLLER

## Getting Started

### BULLETIN 280G/281G



## Introduction

This guide provides the basic information required to start up your ArmorStart<sup>®</sup> Distributed Motor Controller. Factory default settings and information regarding installing, programming, and DeviceNet<sup>™</sup> Node Commissioning are described here. For detailed information on specific product features or configurations, refer to the ArmorStart user manual, publication 280G-UM001\*.

This guide is intended for qualified service personnel responsible for setting up and servicing these devices. You must have previous experience with and a basic understanding of electrical terminology, configuration procedures, required equipment, and safety precautions.

You should understand DeviceNet network operations, including how slave devices operate on a network and communicate with a DeviceNet master. You should also be familiar with RSNetWorx<sup>™</sup> for DeviceNet. **You must use RSNetWorx for DeviceNet Revision 3.21 Service Pack 2 or later.** This software package is referred to often in this manual. Rockwell Automation product EDS files are available on the internet at: <http://www.ab.com/networks/eds>.

## Installation

The ArmorStart Distributed Motor Controller is convection cooled. Operating temperature must be kept between  $-20...40^{\circ}\text{C}$  ( $-4...104^{\circ}\text{F}$ ).

## Dimensions

Dimensions are shown in millimeters (inches). Dimensions are not intended to be used for manufacturing purposes. All dimensions are subject to change.

**Figure 1 Dimensions for IP67/NEMA Type 4**

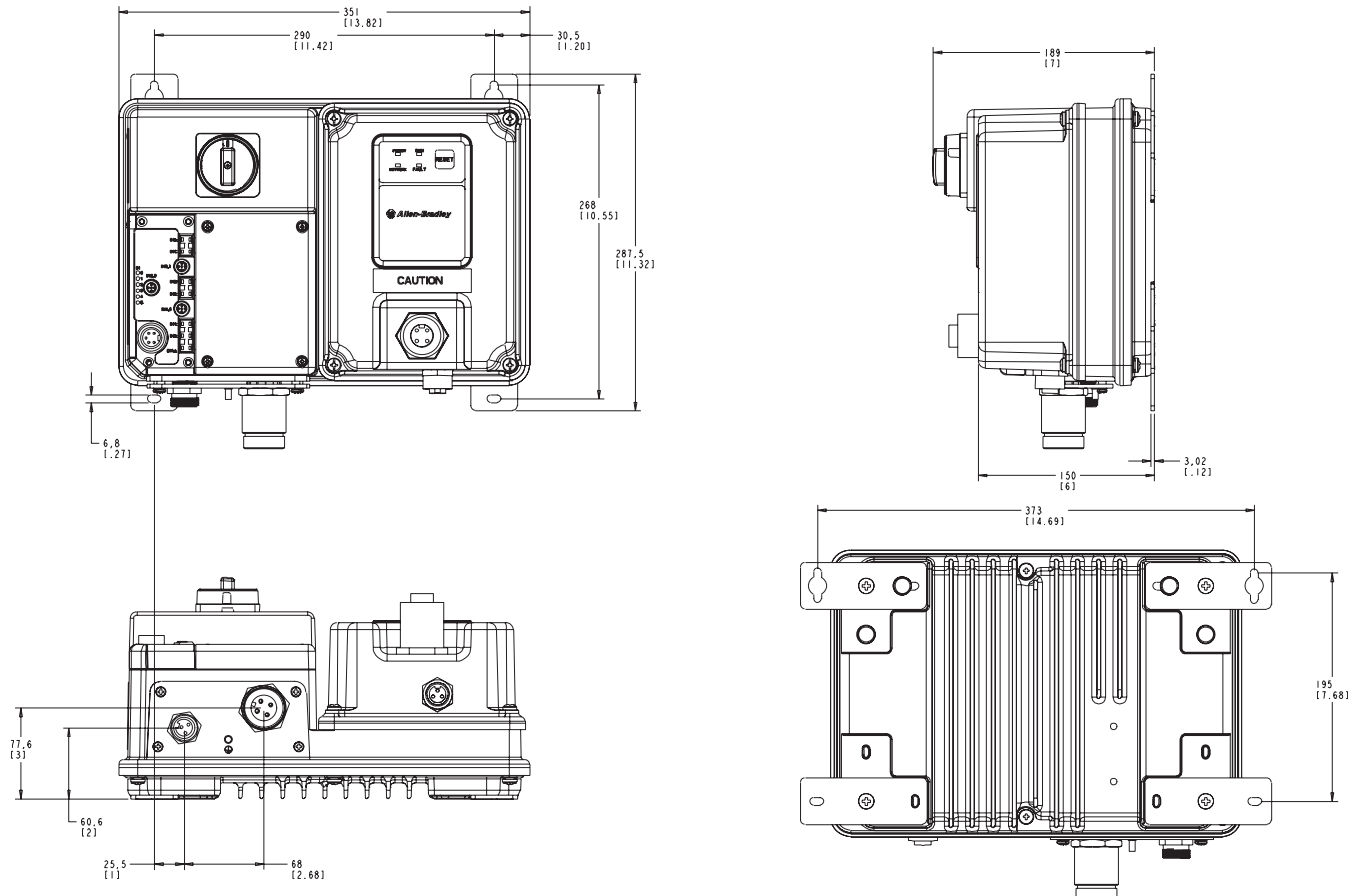

## Wiring

### Power, Control, Safety Monitor Inputs, and Ground Wiring

Table 1 provides the power, control, ground wire capacity, and the tightening torque requirements. The power, control, and ground terminals will accept a maximum of two wires per terminal.

**Table 1 Power, Control, Safety Monitor Inputs, Ground Wire Size, and Torque Specifications**

Terminals	Wire Size	Torque	Wire Strip Length
Three-phase Power and Ground	Primary/Secondary Terminal: 1.5...4.0 mm <sup>2</sup> (#16 ...#10 AWG)	Primary Terminal: 10.8 lb•in. (1.2 N•m) Secondary Terminal: 4.5 lb•in (0.5 N•m)	0.35 in. (9 mm)
Control Power	1.0...4.0 mm <sup>2</sup> (#18...#10 AWG)	6.2 lb•in (0.7 N•m)	0.35 in. (9 mm)

## Terminal Designations

As shown in Figure 2, the ArmorStart Distributed Motor Controller contains terminals for power, control, and ground wiring. Access can be gained by removing the terminal access cover plate.

**Figure 2 ArmorStart Power, Control, and Ground Terminals**

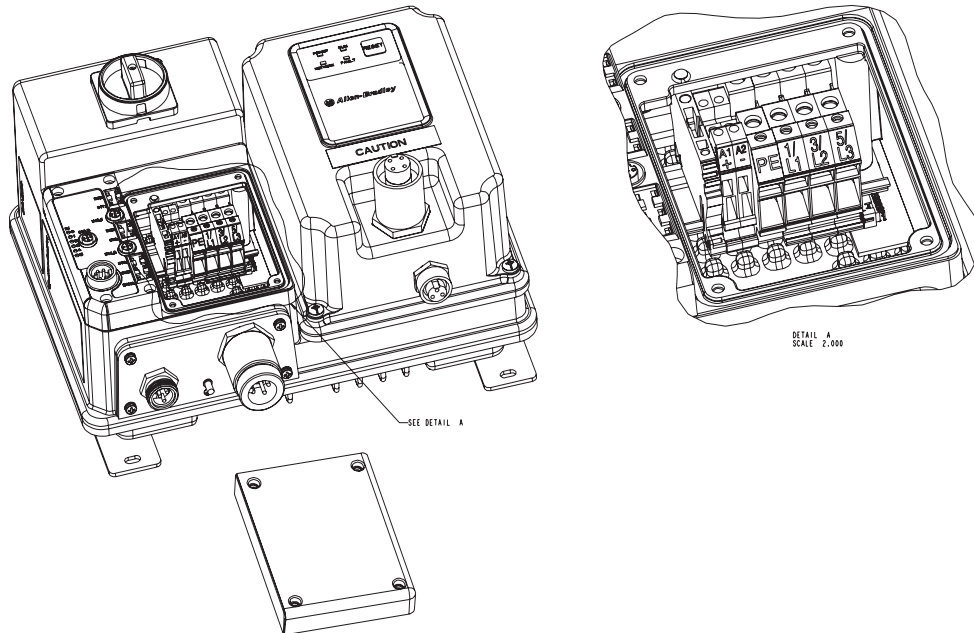

**Table 2 Power, Control, and Ground Terminal Designations**

Terminal Designations	No. of Poles	Description
A1 (+)	2	Control Power Input
A2 (-)	2	Control Power Common
PE	2	Ground
1/L1	2	Line Power Phase A
3/L3	2	Line Power Phase B
5/L5	2	Line Power Phase C

## ArmorConnect Power Media

### Description

The ArmorStart Power Media offers both three-phase and control power cable system of cordsets, patchcords, receptacles, tees, reducers and accessories to be utilized with the ArmorStart Distributed Motor Controller. These cable system components allow quick connection of ArmorStart Distributed Motor Controllers and reduce installation time. They provide for repeatable, reliable connection of the three-phase and control power to the ArmorStart Distributed Motor Controller and motor by providing a plug and play environment that also avoids system mis-wiring. When specifying power media for use with the ArmorStart Distributed Motor Controllers (Bulletins 280, 281, and 284) use only Bulletin 280 ArmorConnect™ power media.

**Figure 3 Three-Phase Power System Overview**

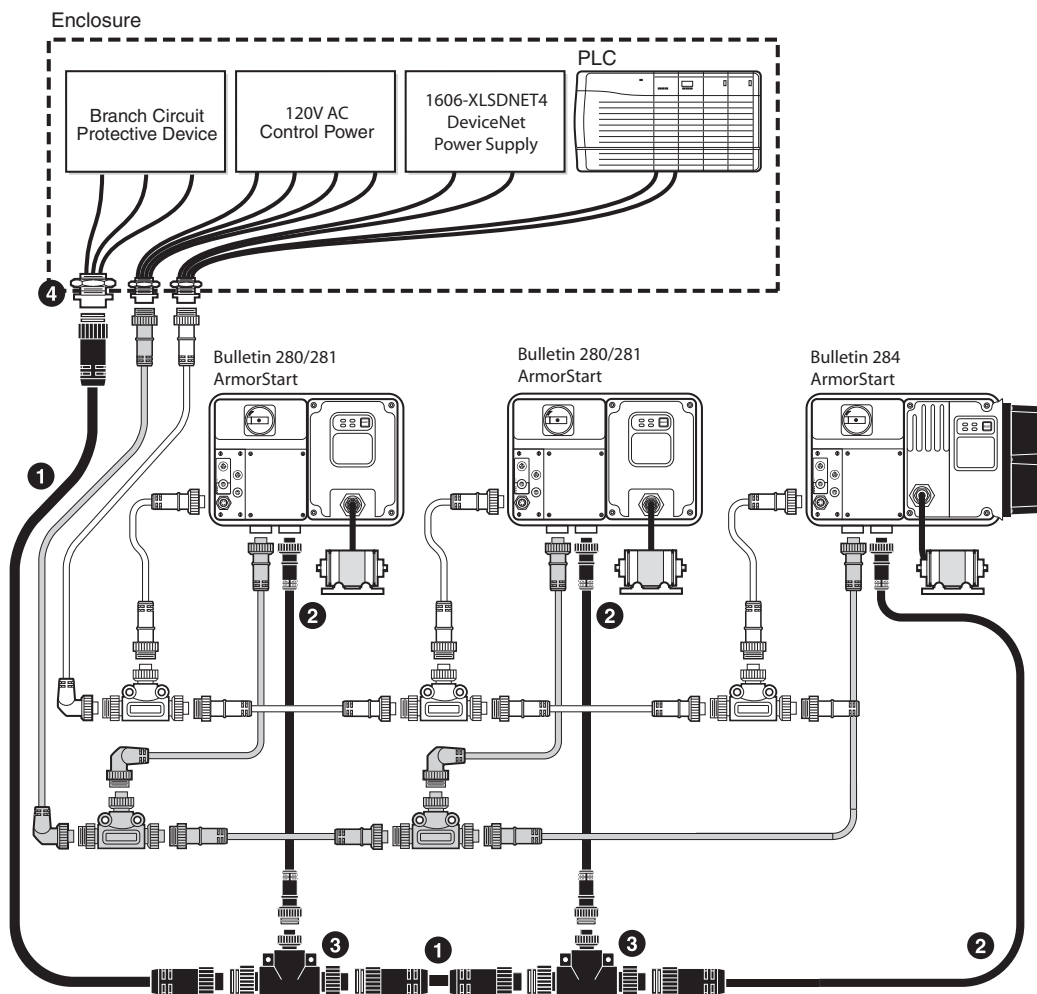

- ❶ Three-Phase Power Trunk- PatchCord cable with integral female or male connector on each end  
Example Part Number: 280-PWR35A-M\*
- ❷ Three-Phase Drop Cable- PatchCord cable with integral female or male connector on each end  
Example Part Number: 280-PWR35A-M\*
- ❸ Three-Phase Power Tee -  
Tee connects to a single drop line to trunk with quick change connectors – Part Number: 280-T35
- ❹ Three-Phase Power Receptacles -  
Female receptacles are a panel mount connector with flying leads – Part Number: 280-M35F-M1

**Figure 4 Control Power Media System Overview**

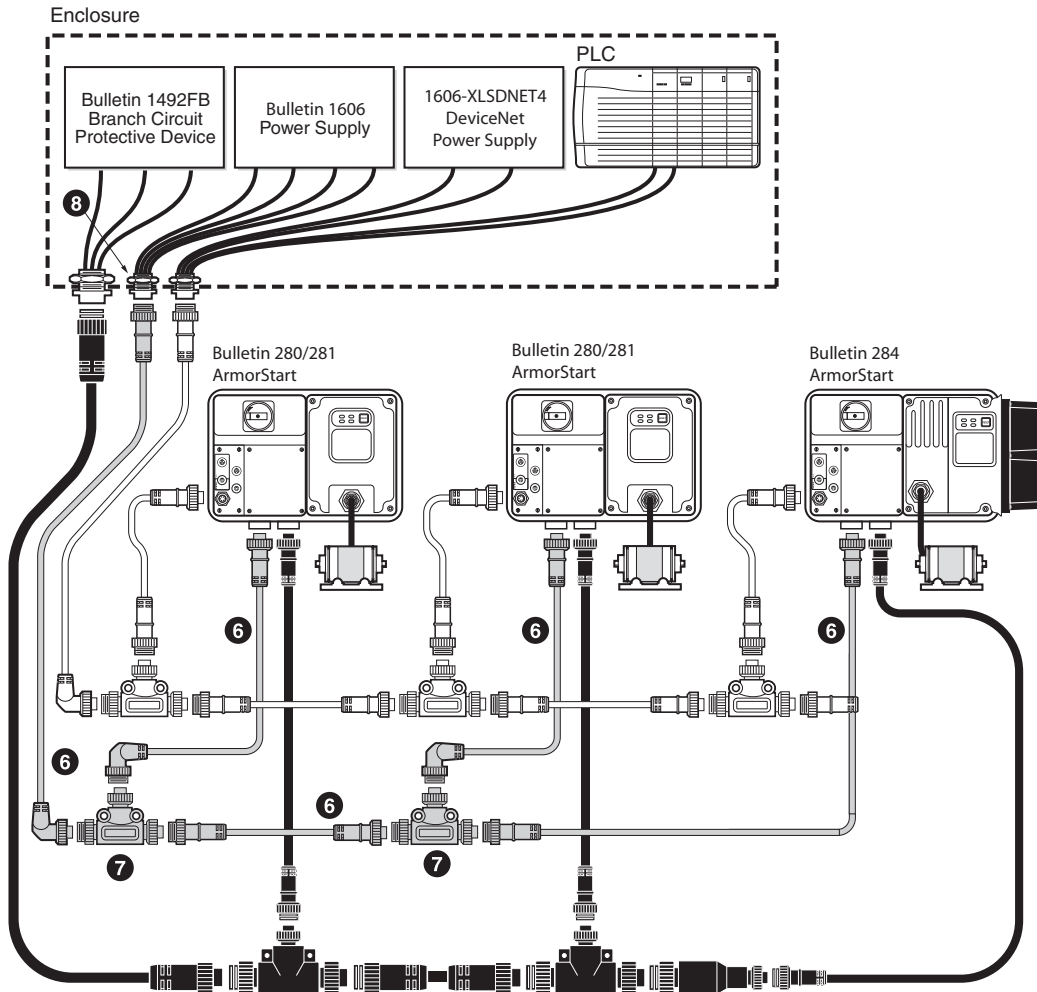

- ⑥ Control Power Media Patchcords - PatchCord cable with integral female or male connector on each end  
Example Part Number: 889N-F3AFNU-\*F
- ⑦ Control Power Tees - The control power tee (Part Number: 898N-33PB-N4KF) is used to connect to the ArmorStart Distributed Motor Controller using a control power media patchcord.
- ⑧ Control Power Receptacles - Female receptacles are a panel mount connector with flying leads –  
Part Number: 888N-D3AF1-\*F

## ArmorStart with ArmorConnect Connectivity

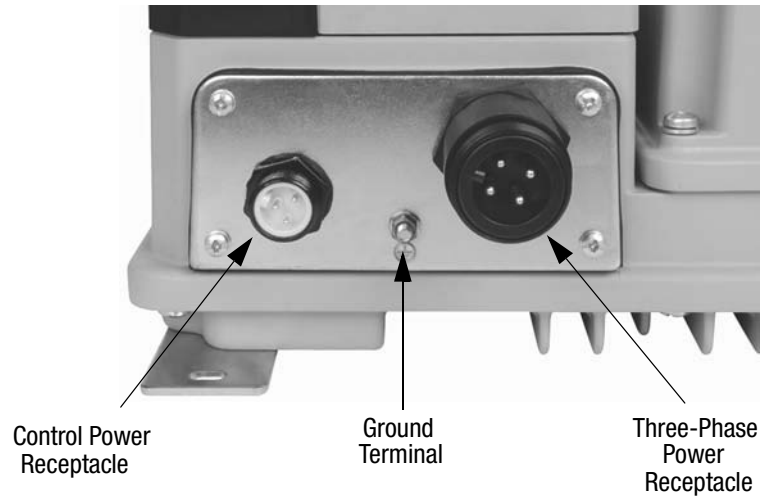

## Terminal Designations



Terminal Designations	Description	Color Code
A1 (+)	Control Power Input	Black
A2 (-)	Control Power Common	White
PE	Ground	Green/Yellow
1/L1	Line Power - Phase A	Black
2/L2	Line Power - Phase B	White
3/L3	Line Power - Phase C	Red

## ArmorConnect Cable Ratings

The ArmorConnect Power Media cables are rated per UL Type TC 600V 90 °C Dry 75 °C Wet, Exposed Run (ER) or MTW 600V 90 °C or STOOW 105 °C 600V - CSA STOOW 600V FT2. For additional information regarding ArmorConnect Power Media see the ArmorStart User Manual.

## Branch Circuit Protection Requirements for ArmorConnect™ Three-Phase Power Media

When using ArmorConnect Three-Phase Power Media, only fuses can be used for the motor branch circuit protective device, for the group motor installations. The recommended fuse types are the following: Class CC, T, or J type fuses. A 100 A circuit breaker can be used for the motor branch protective device, for the group motor installations when using **only** the following ArmorConnect power media components: 280-M35M-M1, 280-M35F-M1, 280-T35, and 280-PWRM35\*-M\*. For additional information, see the ArmorStart User Manual.

---

## Group Motor Installations for USA and Canada Markets

The ArmorStart Distributed Motor controllers are listed for use with each other in group installations per NFPA 79, Electrical Standard for Industrial Machinery. When applied according to the group motor installation requirements, two or more motors, of any rating or controller type, are permitted on a single branch circuit. Group Motor Installation has been successfully used for many years in the USA and Canada.

### Wiring and Workmanship Guidelines

In addition to conduit and seal-tite raceway, it is acceptable to utilize cable that is dual rated Tray Cable, Type TC-ER and Cord, STOOW, for power and control wiring on ArmorStart installations. In the USA and Canada installations, the following guidance is outlined by the NEC and NFPA 79.

In industrial establishments where the conditions of maintenance and supervision ensure that only qualified persons service the installation, and where the exposed cable is continuously supported and protected against physical damage using mechanical protection, such as struts, angles, or channels, Type TC tray cable that complies with the crush and impact requirements of Type MC (Metal Clad) cable and is identified for such use with the marking Type TC-ER (Exposed Run)\* shall be permitted between a cable tray and the utilization equipment or device as open wiring. The cable shall be secured at intervals not exceeding 1.8 m (6 ft) and installed in a “good workman-like” manner. Equipment grounding for the utilization equipment shall be provided by an equipment grounding conductor within the cable.

\*Historically cable meeting these crush and impact requirements were designated and marked “Open Wiring”. Cable so marked is equivalent to the present Type TC-ER and can be used.

While the ArmorStart is intended for installation in factory floor environments of industrial establishments, the following must be taken into consideration when locating the ArmorStart in the application: Cables, including those for control voltage including 24V DC and communications, are not to be exposed to an operator or building traffic on a continuous basis. Location of the ArmorStart to minimize exposure to continual traffic is recommended. If location to minimize traffic flow is unavoidable, other barriers to minimize inadvertent exposure to the cabling should be considered. Routing cables should be done in such a manner to minimize inadvertent exposure and/or damage.

Additionally, if conduit or other raceways are not used, it is recommended that strain relief fittings be utilized when installing the cables for the control and power wiring through the conduit openings.

The working space around the ArmorStart may be minimized as the ArmorStart does not require examination, adjustment, servicing or maintenance while energized. In lieu of this service, the ArmorStart is meant to be unplugged and replaced after proper lockout/tag-out procedures have been employed.

### **DeviceNet Network Installation**

The ArmorStart Distributed Motor Controller contains the equivalent of 30 in. (0.76 m) of DeviceNet drop cable's electrical characteristics and therefore 30 in. of drop cable must be included in the DeviceNet drop cable budget for each ArmorStart in addition to actual drop cable required for the installation.

### **Other DeviceNet System Design Considerations**

The separation of the control power and DeviceNet power is recommended as a good design practice. This minimizes the load on the DeviceNet supply, and prevents transients which may be present on the control power system from influencing the communication controls.

## LED Status Indication

The LED Status Indication provides 4 status LEDs and a Reset button. The LEDs provide status indication for the following:

- **POWER LED**  
The LED is illuminated solid green when control power is present and with the proper polarity
- **RUN LED**  
This LED is illuminated solid green when a start command and control power are present
- **NETWORK LED**  
This bi-color (red/green) LED indicates the status of the communication link
- **FAULT LED**  
Indicates Controller Fault (trip) condition

The “Reset Button” as a local trip reset.

**Figure 5 LED Status Indication and Reset**



## DeviceNet Node Commissioning Establishing a DeviceNet Node Address

The ArmorStart is shipped with a default node address of 63 and Autobaud enabled. Each device on a DeviceNet network must have a unique node address or MAC ID which can be set to a value from 0...63. Keep in mind that most DeviceNet systems use address 0 for the master device (Scanner) and node address 63 should be left vacant for introduction of new slave devices. The ArmorStart offers two methods for node commissioning as shown in the following pages.

### Node Commissioning using Software

To set the node address of the ArmorStart using software or other handheld tools, leave the hardware rotary switches in their default position (99) or insure that they are set to something greater than (63). With the hardware switches set, use the software or handheld tool to change the address.

When using software to node commission a device, it may be necessary to have the EDS file stored on the computer. The EDS file defines how the software such as RSNetWorx for DeviceNet will communicate to the ArmorStart. **You must use RSNetWorx for DeviceNet Revision 3.21 Service Pack 2 or later.**

## Node Commissioning using Hardware

The ArmorStart is shipped with the hardware rotary switches set to a value of (99). If the switches are set to a value of (64) or above, the device will automatically configure itself to the software node address. If the switches are set to a value of (63) or less, the device will be at the node address designated by the switch configuration.

To set an address using the hardware rotary switches, simply set the switches to the desired node address. To access the node address rotary switches, three-phase and control power should be turned off. Then remove the starter module from the base unit. The rotary node address switches are located on the back side of the starter module. Change the switches to the desired node address. Re-install the starter module to the base unit. Reapply power and the device will re-start at the new address.

**Figure 6 Rotary Node Address Configuration**

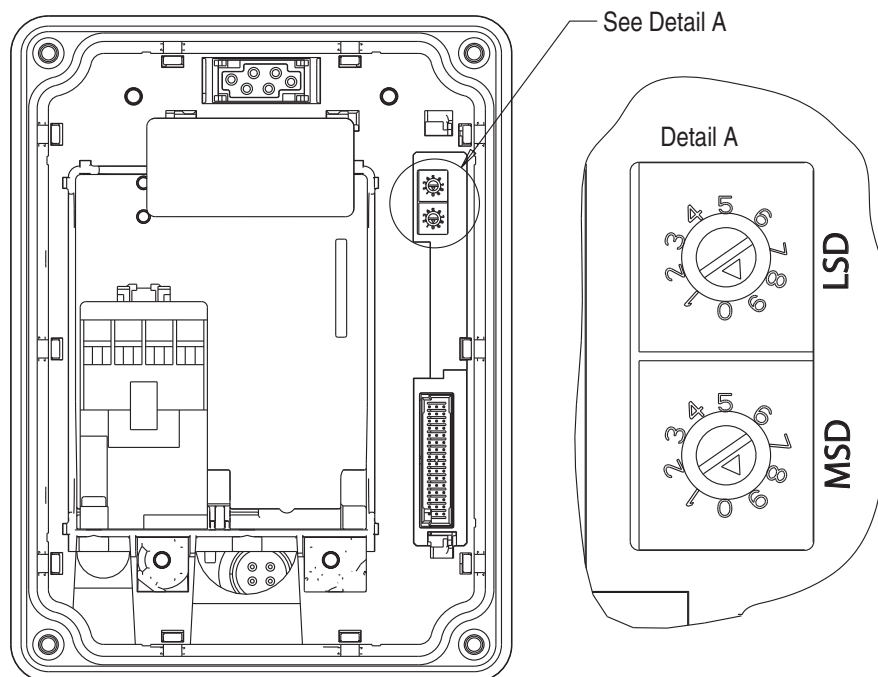

## System Configuration Information

The following information is provided to identify the default method for setting up communication to the ArmorStart. Additional configuration information and advanced settings help can be found in the ArmorStart User Manual, Publication 280G-UM001\*.

## Using Automap feature with default Input and Output (I/O) assemblies

The Automap feature available in all Rockwell Automation scanners will automatically map the information as shown below. If manual mapping is required, the information below can be used to map a device based on the default configuration.

**Table 3 Default I/O Messaging Data**

	Default
Message type	Polled
Consumed data size	1 byte (Rx)
Produced data size	2 bytes (Tx)

## Default Input and Output (I/O) Assembly Formats

The I/O assembly formats for the ArmorStart are identified by the value in parameter 11 (Consumed IO Assy.) and parameter 12 (Produced IO Assy.). These values determine the amount and arrangement of the information communicated to the master scanner. The tables below identify the default information produced and consumed by DOL (Bulletin 280) and Reversing (Bulletin 281) devices. For additional formats and advance configurations please reference the user manual:

### Defaults for Standard Distributed Motor Controllers

**Table 4 Instance 160 - Default Consumed data for Standard Distributed Motor Controller Output information arrangement (1 byte)**

Byte	Bit 7	Bit 6	Bit 5	Bit 4	Bit 3	Bit 2	Bit 1	Bit 0
0	Not Used	Not Used	Not Used	Not Used	Not Used	Fault Reset	Run Rev	Run Fwd

**Table 5 Instance 161 - Default Produced data for Standard Distributed Motor Controller Input information arrangement (2 bytes)**

Byte	Bit 7	Bit 6	Bit 5	Bit 4	Bit 3	Bit 2	Bit 1	Bit 0
0	Not Used	140M On	Not Used	Ready	Running Rev	Running Fwd	Warning	Tripped
1	Not Used	Not Used	User In 5	User In 4	User In 3	User In 2	User In 1	User In 0

## Setting the Motor FLA and Overload Trip Class

The product should now be configured and communicating on the network. The last step is to program the proper motor FLA setting (parameter #106) and overload trip class (parameter #107). This can be accomplished by using software such as RSNetWorx for DeviceNet or a handheld DeviceNet tool.

Use the software to access the device parameters screen. By default the motor FLA is set to the minimum FLA setting for the device and the overload trip class is set to 10. Set these parameters to the desired values and download to the device.

Select **FLA setting** (parameter #106) and enter a value that corresponds to the FLA of the motor connected to the ArmorStart. Make sure the **Single** radio button is selected and then select **Download to Device**.

Select **Overload Class** (parameter #107) and choose the overload trip class to be used with the motor connected to the ArmorStart. The ArmorStart can be set up for trip class 10, 15, or 20. Make sure the **Single** radio button is selected and then select **Download to Device**.

The proper motor protection is now in place.

**Figure 7 RSNetWorx Parameter Screen**

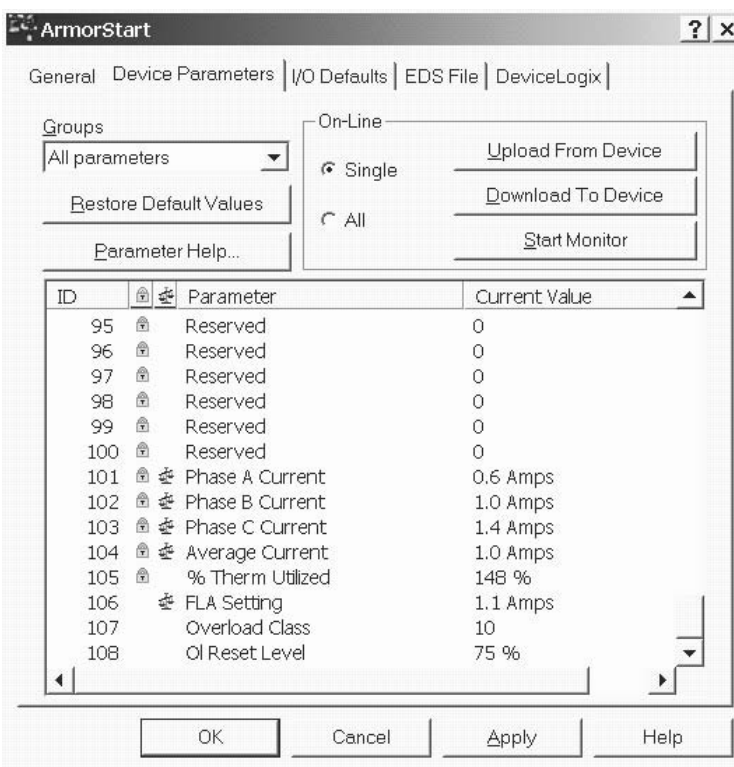

## Quick Reference Troubleshooting

There are four LEDs on the front of the ArmorStart that can provide an indication as to the health of the device. The following is a brief explanation of the operation of each LED.

**Table 6 LED Status Indication**

LED	Definition
Power	This LED will be illuminated solid green when control power is present and with the proper polarity.
Run	This LED will be illuminated solid green when a start command and control power is present.
Network	This bi-color LED is used to indicate the status of the DeviceNet network. See the Network Status LED table below for additional information.
Fault	This LED is used to indicate the fault status of the ArmorStart. When the unit is faulted, the unit will respond with a specific blink pattern to identify the fault. See the Fault LED table below for additional information.

**Table 7 Network LED Status Indication**

Network Status LED	Definition	Possible Causes
Off	The device has not completed the initialization, is not on an active network, or may not be powered up.	Check to make sure the product is properly wired and configured on the network.
Flashes green-red-off	While waiting to detect the network baud rate, the LED will flash this pattern about every 3 seconds.	If the product stays in this state it means that there is no set baud rate. Insure that at least one device on the network has a set baud rate.
Solid Green	The device is operating in a normal condition, and is communicating to another device on the network.	No action required.
Flashing Green	The device is operating in a normal condition, is on-line, but with no connection to another device. This is the typical state for new devices.	The device may need to be mapped to a master scanner, placed in a scanlist, or have another device communicate to it.
Flashing Red	Recoverable fault has occurred.	Check to make sure the PLC and scanner are operating correctly and that there are no media/cabling issues. Check to see if other networked devices are in a similar state.
Solid Red	The device has detected a major error that has rendered it incapable of communicating on the network (Duplicate MAC ID, Bus-off, media issue).	Troubleshooting should be done to ensure that the network is correct (terminators, lengths, etc.) and there is not a duplicate node problem. If other devices on the network appear to be operating fine and power cycling the device does not work, contact Technical Support.
Flashing Red and Green	The device is in a communication faulted state.	Power cycling the device may resolve the problem; however, if the problem continues, it may be necessary to contact Technical Support.

## Fault LED indications for Bulletin 280G and 281G ArmorStart Distributed Motor Controllers

**Table 8 Controller Fault LED Definitions**

Blink Pattern	Definitions	Possible Causes or Remedies
1	Short Circuit	The motor circuit protector has tripped, or the internal wiring protection algorithm has detected an unsafe current range. Try to reset the protector if tripped. If the condition continues, check the power wiring. This fault cannot be disabled.
2	Overload trip	The load has drawn excessive current and based on the trip class selected, the device has tripped. Verify that the load is operating correctly and the ArmorStart is properly set-up. This fault cannot be disabled.
3	Phase Loss	The ArmorStart has detected a missing phase. Verify that three-phase voltage is present at the line side connections. This fault can be disabled and <i>is</i> disabled by default.
4	Reserved	Not Used
5	Reserved	Not Used
6	Control Power	The ArmorStart has detected a loss of the control power voltage. Check control voltage, wiring, and proper polarity. Also, check and replace the control voltage fuse ,if necessary. This fault can be disabled and <i>is</i> disabled by default.
7	I/O Fault	This error indicates a shorted sensor, shorted input device, or wiring input mistakes. If this fault occurs, the offending problem should be isolated or removed prior to restarting the system. This fault can be disabled and <i>is</i> disabled by default.
8	Over Temperature	This fault is generated when the operating temperature has been exceeded. This fault cannot be disabled.
9	Phase Imbalance	The ArmorStart has detected a voltage imbalance. Check the power system and correct if necessary. This fault can be disabled and <i>is</i> disabled by default.
10	DNet Power Loss	DeviceNet power has been lost or has dropped below the 12V threshold. Check the state of the network power supply and look for DeviceNet media problems. This fault can be disabled and <i>is</i> disabled by default.
11	Reserved	Not Used
12	Reserved	Not Used
13	EEPROM Fault	This is a major fault, which renders the ArmorStart inoperable. Possible causes of this fault are transients induced during EEprom storage routines. If the fault was, initiated by a transient, power cycling should clear the problem otherwise replacement of the ArmorStart may be required. This fault cannot be disabled.
14	Hardware Fault	This fault indicates that a serious hardware problem exists. Check for a base/starter module mismatch. If no mismatch exists, the Armor Start may need to be replaced. (Hdw Flt is the factory-enabled default setting.) This fault cannot be disabled.

## Bulletin 280G/281G Parameters

**Table 9 Starter Display and Parameter Settings**

Parameter	Name String	Path (hex)	Min	Max	Dflt	Type	Value
<b>Starter Display</b>							
101	Phase A Current	002C – 01 – 08	0	32767	—	INT	xxx.x Amps
102	Phase B Current	002C – 01 – 09	0	32767	—	INT	xxx.x Amps
103	Phase C Current	002C – 01 – 0A	0	32767	—	INT	xxx.x Amps
104	Average Current	002C – 01 – 05	0	32767	—	INT	xxx.x Amps
105	% Therm Utilized	002C – 01 – 07	0	100	—	USINT	xxx %
<b>Starter Settings</b>							
106	FLA Setting	002C – 01 – 03	See Table 10 below		Min I	INT	xxx.x Amps
107	OL Trip Class	002C – 01 – 04	0	3	1	BYTE	1 = 10 2 = 15 3 = 20
108	OL Reset Level	0029 – 01 – 131	0	100	75	BYTE	xxx %

**Table 10 FLA Setting Ranges and Default Values (with indicated setting precision)**

FLA Current Range (A)		Default Value
Minimum Value	Maximum Value	
0.5	2.5	0.5
1.1	5.5	1.1
3.2	16.0	3.2

Figure 8 Bulletin 280G/281G ArmorStart

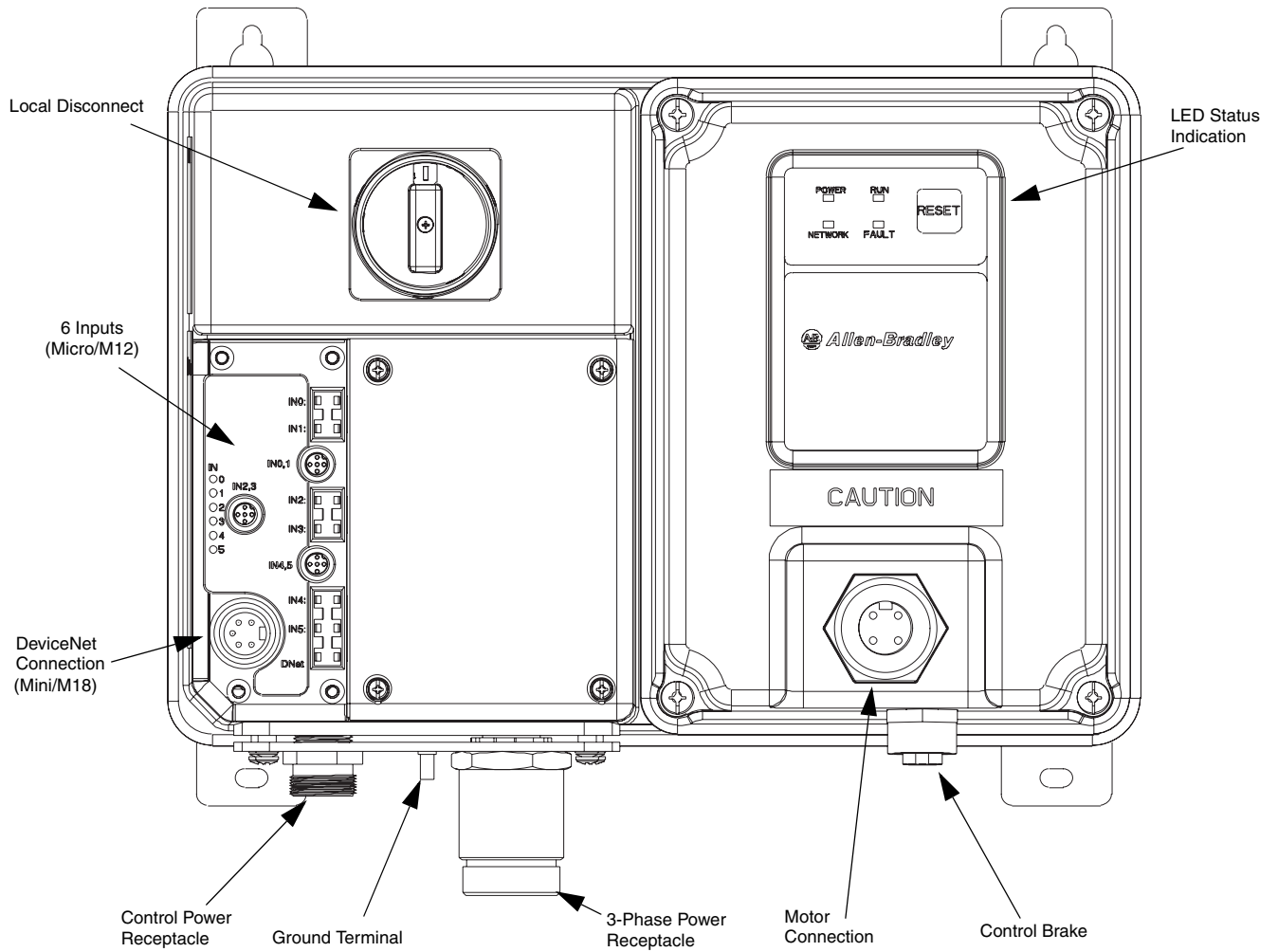





Table 11 DeviceNet Media <sup>①</sup>



Description		Length m (ft)	Cat. No.
	KwikLink pigtail drops are Insulation Displacement Connector (IDC) with integral Class 1 round cables for interfacing devices or power supplies to flat cable		Sealed
		1 m (3.3)	1485P-P1E4-B1-N5
		2 m (6.5)	1485P-P1E4-B2-N5
		3 m (9.8)	1485P-P1E4-B3-N5
		6 m (19.8)	1485P-P1E4-B6-N5
	DeviceNet Mini- T-Port Tap	Right Keyway Left Keyway	1485P-P1N5-MN5NF 1485P-P1N5-MN5KM
	Gray PVC Thin Cable	<b>Connector</b>	<b>Cat. No.</b>
		Mini Straight Female Mini Straight Male	1485G-P <sup>②</sup> N5-M5
		Mini Straight Female Mini Right Angle Male	1485G-P <sup>②</sup> W5-N5
		Mini Right Angle Female Mini Straight Male	1485G-P <sup>②</sup> M5-Z5
	Thick Cable	Mini Straight Female Mini Straight Male	1485C-P <sup>③</sup> N5-M5
		Mini Straight Female Mini Right Angle Male	1485C-P <sup>③</sup> W5-N5
		Mini Right Angle Female Mini Straight Male	1485C-P <sup>③</sup> M5-Z5
		Mini Right Angle Female Mini Straight Male	1485C-P <sup>③</sup> W5-Z5

① See publication M116-CA001A-EN-P for complete cable selection information.

② Replace symbol with desired length in meters (Example: 1485G-P1N5-M5 for a 1 m cable). Standard cable lengths: 1 m, 2 m, 3 m, 4 m, 5 m, and 6 m.

③ Replace symbol with desired length in meters (Example: 1485C-P1N5-M5 for a 1 m cable). Standard cable lengths: 1 m, 2 m, 3 m, 4 m, 5 m, 6 m, 8 m, 10 m, 12 m, 18 m, 24 m, and 30 m.

**Table 12 Sensor Media <sup>①</sup>**

Description	ArmorStart I/O Connection	Pin Count	Connector	Cat. No.
 DC Micro Patchcord	Input	5-Pin	Straight Female Straight Male	889D-F4ACDM- <sup>②</sup>
			Straight Female Right Angle Male	889D-F4AACDE- <sup>②</sup>
 DC Micro V-Cable	Input	5-pin	Straight Female	879D-F4ACDM- <sup>②</sup>
			Right Angle Male	879D-R4ACM- <sup>②</sup>
 AC Micro Patchcord	Output	3-pin	Straight Female Straight Male	889R-F3AERM- <sup>②</sup>
			Straight Female Right Angle Male	899R-F3AERE- <sup>②</sup>

① See Publication M116-CA001A-EN-P for complete cable selection information.

② Replace symbol with desired length in meters (Example: 889D-F4ACDM-1 for a 1 m cable). Standard cable lengths: 1 m, 2 m, 5 m, and 10 m.

**Table 13 Sealing Caps <sup>③</sup>**

Description	Used on I/O Connection	Catalog Number
Plastic Sealing Cap (M12)	Input	1485A-M12

③ To achieve IP67 rating, sealing caps must be installed on all unused I/O connections.

**Notes:**

Registered Trademark List

ArmorPoint and ArmorStart are registered trademarks of Rockwell Automation, Inc.

Trademark List

ArmorConnect, RSLogix5000, PLC, RSNetWorx, and SLC are trademarks of Rockwell Automation, Inc. DeviceNet and the DeviceNet logo are trademarks of the Open Device Vendors Association (ODVA).

**[www.rockwellautomation.com](http://www.rockwellautomation.com)**

---

**Power, Control and Information Solutions Headquarters**

Americas: Rockwell Automation, 1201 South Second Street, Milwaukee, WI 53204-2496 USA, Tel: (1) 414.382.2000, Fax: (1) 414.382.4444

Europe/Middle East/Africa: Rockwell Automation, Vorstlaan/Boulevard du Souverain 36, 1170 Brussels, Belgium, Tel: (32) 2 663 0600, Fax: (32) 2 663 0640

Asia Pacific: Rockwell Automation, Level 14, Core F, Cyberport 3, 100 Cyberport Road, Hong Kong, Tel: (852) 2887 4788, Fax: (852) 2508 1846