

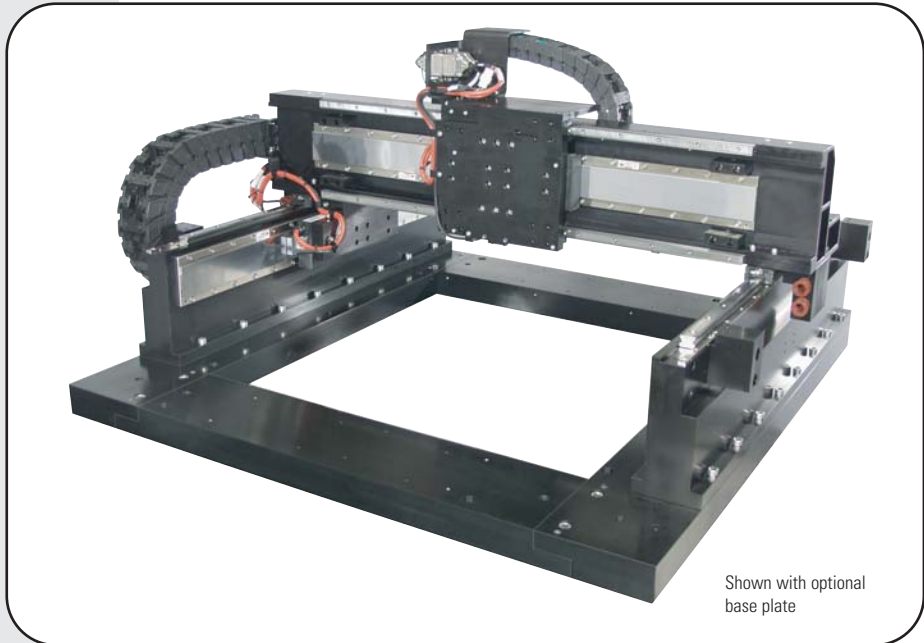

Hercules Series Gantry

Product Features

- Low-cost modular design
- Optional modular base plate offers flexibility with work surface fixturing
- XY travels from 250-to-650 mm
- High output iron core or zero cogging motors
- Dual-motor Y axis options for high-speed precision applications
- Compact Footprint maximizes use of production area



Hercules Series Gantry

Hercules Series Gantry X-Y stages

Anorad's standard low cost Hercules Series Gantries are designed for economy and performance. Their highly efficient layout provides the best utilization ratio of system X-Y travel to overall gantry footprint.

The Hercules family of gantries are designed to address a multitude of performance requirements for inspection, pick-and-place, assembly or dispensing applications. Taking advantage of economies-of-scale, the Hercules gantry stages are based on a single platform design. Many linear servo motor selections, linear encoder options and several travel lengths allow Anorad to uniquely support a variety of applications with a cost effective solution.

The standard model Hercules gantries feature Anorad's new LC iron core linear motors. These motors are ideally suited to meet the rapid point-to-point motion common in the electronics assembly industry. These high force LC motors, combined with a low mass X-axis crossbeam, allows high acceleration to maximize throughput.

Additional design features include cable carriers terminating at a fixed bulkhead connector. This provides for easy integration. Travel limits for both the X and Y axes are adjustable to optimize total work area. A variety of optical encoders with multiple resolutions can be selected based upon application requirements.

The Hercules Gantry is the first of its type to offer a standard modular base plate to reduce total gantry cost in a standard base configuration. This innovative design offers user flexibility with work surface fixturing and interchangeability. The modular base allows the machine builder to utilize the same machine on differently tooled multiple lines.

In addition to all these features, the Hercules Series Gantries can be supplied with many desirable value-added options including Z axis or Theta axis modules, servo drive and control packages, machine frames, enclosures and the complete line of over 500,000 world-class industrial automation products available only from Rockwell Automation.

Product Profile

**Rockwell
Automation**



Specifications ⁽¹⁾

Specification	Units	Hercules 100	Hercules 200
Travel Options ⁽²⁾	mm	250, 400, 510, 650	250, 400, 510, 650
Motor Options (see Table #1 below) (X/Y)	-	(A - D)/(A - F)	(A - D)/(A - F)
Encoder Resolution (see Table #2 below)	-	A	B & C
Flatness of Travel (X/Y)	μm	± 25/± 25	± 15/± 10
Straightness of Travel (X/Y)	μm	± 20/± 20	± 10/± 15
Orthogonality (X-to-Y)	arc-sec	± 10	± 10
Accuracy (center travel) (X/Y)	μm	± 25/± 30	± 10/± 15
Repeatability	μm	± 15	± 5
Max Velocity ⁽³⁾	m/sec	2.0	2.0
Maximum Payload on X-axis	kg	20	20

Notes:

- (1) Specifications are stated per axis for Model HER-510-510-AA1 at midpoint of travel. Values may differ slightly for other models.
- (2) The longer length of optional LEB-S-6 motor coils reduces the standard X-axis and Y-axis travel by 120mm (± 60mm from center).
- (3) Maximum velocity may be limited by a combination of encoder resolution, controller input frequency, and supply voltage.
- (4) Dual Y-axis motor option only.

Table #1

Linear Motors

Code	Model
A	LC-050-200D
B	LC-050-200E
C	LEB-S-4
D ₍₂₎	LEB-S-6
E ₍₄₎	LC-075-200D
F ₍₄₎	LC-075-200E

Table #2

Encoder Resolution

Code	Model
A	5.0μm
B	1.0μm
C	0.5μm

Note:

X-axis carriage on the Y-axis moving beam.

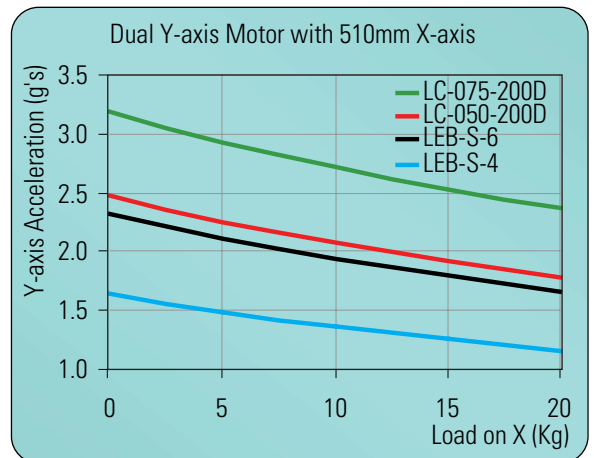
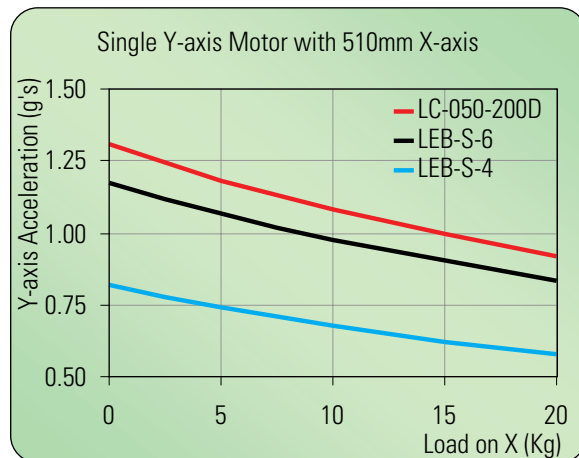
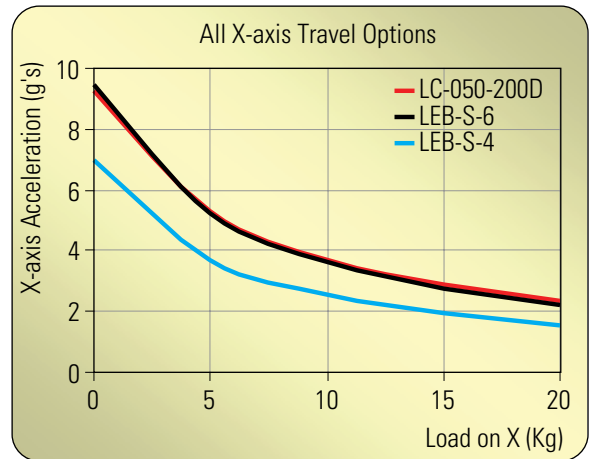

Hercules Series Gantry Outline (Shown with optional base plate)

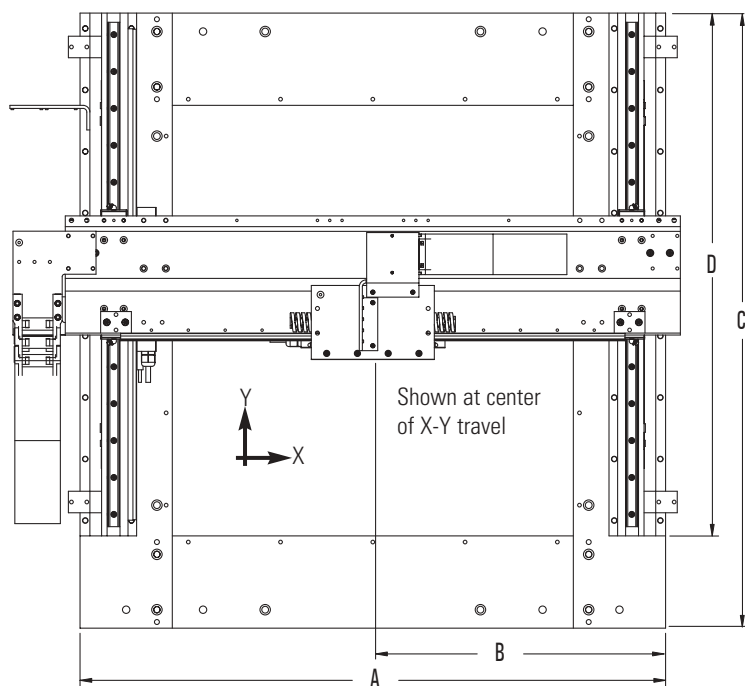

X-Axis Moving Mass vs X-Motor	
Motor	Moving Mass
LC-050-200	6.69 kg
LEB-S-4	5.70 kg
LEB-S-6	6.10 kg

Y-Axis Moving Mass (kg) vs X-Travel ^(a)				
X-Travel	LC-50-200	LC-75-200	LEB-S-4	LEB-S-6
250	40.2	45.7	39.9	40.7
400	44.5	50.7	45.0	47.2
510	47.4	53.8	48.1	49.2
650	51.5	59.2	53.2	54.0

(a) Matching motors used in X-Axis and Y-axis.
 For dual LC-050-200 Y-axis motors, add 3.2 kg
 For dual LC-075-200 Y-axis motors, add 4.7 kg
 For dual LEB-S-4 Y-axis motors, add 1.1 kg
 For dual LEB-S-6 Y-axis motors, add 1.5 kg

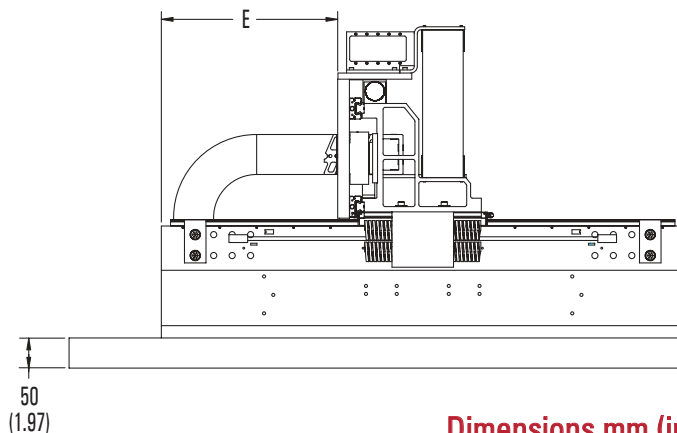
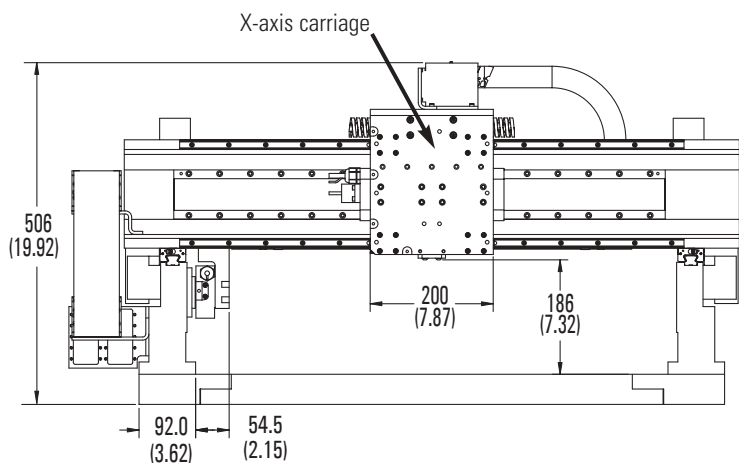

Dimensions mm (in)

X-Axis	X-Travel	A	B
HER-250-YYY	250 (9.84)	692 (27.24)	346 (13.62)
HER-400-YYY	400 (15.75)	842 (33.15)	421 (16.57)
HER-510-YYY	510 (20.08)	952 (37.48)	476 (18.74)
HER-650-YYY	650 (25.59)	1092 (42.99)	546 (21.50)

Y-Axis	Y-Travel	C	D	E
HER-XXX-250	250 (9.84)	741 (29.17)	600 (23.62)	161.7 (6.37)
HER-XXX-400	400 (15.75)	901 (35.47)	760 (29.92)	241.7 (9.51)
HER-XXX-510	510 (20.08)	1000 (39.37)	850 (33.46)	286.7 (11.29)
HER-XXX-650	650 (25.59)	1145 (45.08)	1000 (39.37)	361.7 (14.24)

Specifications subject to change. Please consult Anorad for latest information.

**Rockwell
Automation**

Ordering Information

Part Number: Hercules Gantry

Feature	Product Family	Travel		Motors			Encoder Resolution	Series Type
		X-Axis	Y-Axis	X-Axis	Y-Axis	# Y		
	HER	510	510	A	A	1	C	1-CC 2
X-axis Travel (mm)								
250								
400								
510								
650								
Y-axis Travel (mm)								
250								
400								
510								
650								
X-axis Motor⁽¹⁾								
(A) LC-50-200D (Standard)								
(B) LC-50-200E								
(C) LEB-S-4								
(D) LEB-S-6								
Y-axis Motor⁽¹⁾								
(A) LC-050-200D (Standard)								
(B) LC-050-200E								
(C) LEB-S-4								
(D) LEB-S-6								
(E) LC-075-200D (Dual Motor Option Only)								
(F) LC-075-200E (Dual Motor Option Only)								
# of Y-axis Motors								
1 (standard)								
2 (dual option)								
Encoder Resolution								
(A) 5.0 µm								
(B) 1.0 µm								
(C) 0.5 µm								
Series Type								
1 = 100								
2 = 200								

Indicates Customization

- (1) LC - __ _ 200D winding match high current/low voltage (230Vac) drive.
LC - __ _ 200E windings are suited to low current/high voltage (460Vac) drives.
LEB motors are rated at 230 Vac Max.
LC motors are rated at 460 Vac Max.

Part Number: Optional Four Piece Base Plate

Base Part #	Travel	
	X-Axis	Y-Axis
C620670 -	510	510
X-axis Travel (mm)		
250		
400		
510		
650		
Y-axis Travel (mm)		
250		
400		
510		
650		

www.anorad.com www.rockwellautomation.com

Anorad Linear Motion Solutions Headquarters

Americas: Rockwell Automation, 100 Precision Drive, Shirley, NY, 11967-4710, USA, Tel: (1) 631.344.6600, Fax: (1) 631.344.6601
 Europe: Rockwell Automation, De Dintel, 8-12, 5684 PS Best, The Netherlands, Tel: (31) 499 33 8585, Fax: (31) 499 33 8580
 Israel: Rockwell Automation, Sha'ar Yokne'am, Tavor #2, Yokne'am Illit, 20692, Tel: +972.4.909.5222, Fax: +972.4.909.5200
 Japan: Rockwell Automation, 6-5, Nishiki 1-chrome, Naka-ku, Nagoya 460-0003, Japan, Tel: +81.52.222.7060, Fax: +81.52.222.7065
 Korea: Rockwell Automation, 16F, 17F Samhwa Bd., 144-17, Samsung-dong, Gangnam-gu, Seoul, Korea 135-280, Tel+82.2.2188.4400, Fax: +82.2.564.8760

Power, Control and Information Solutions Headquarters

Americas: Rockwell Automation, 1201 South Second Street, Milwaukee, WI 53204-2496 USA, Tel: (1) 414.382.2000, Fax: (1) 414.382.4444
 Europe/Middle East/Africa: Rockwell Automation, Vorstlaan/Boulevard du Souverain 36, 1170 Brussels, Belgium, Tel: (32) 2 663 0600, Fax: (32) 2 663 0640
 Asia Pacific: Rockwell Automation, Level 14, Core F, Cyberport 3, 100 Cyberport Road, Hong Kong, Tel: (852) 2887 4788, Fax: (852) 2508 1846