

# MIGRATION SOLUTIONS

## GE FANUC AUTOMATION

Your equipment is your livelihood. Day in and day out, it's what enables you to get quality product to your customer on time, every time. As your equipment ages, it's inevitable that questions about part sourcing, service, potential productivity gains from new technology, and increased risks of downtime become stronger. You need to work with a supplier that has the product, service, and industry knowledge to partner with you on an upgrade strategy that will help you maximize your competitive advantage in the years ahead. Rockwell Automation and its partners will work out the right plan to fit your control needs and your long-term goals. We can help you migrate all at once or in stages, at the pace that is comfortable for you and that fits your budget.

### WE CAN GET YOU FROM HERE...

- Uncertain parts and service sourcing
- Limited network options
- Weakening technical service
- High repair costs
- High downtime risks
- Questionable reliability of older electronics
- No warranty coverage
- Old equipment that lacks production efficiency

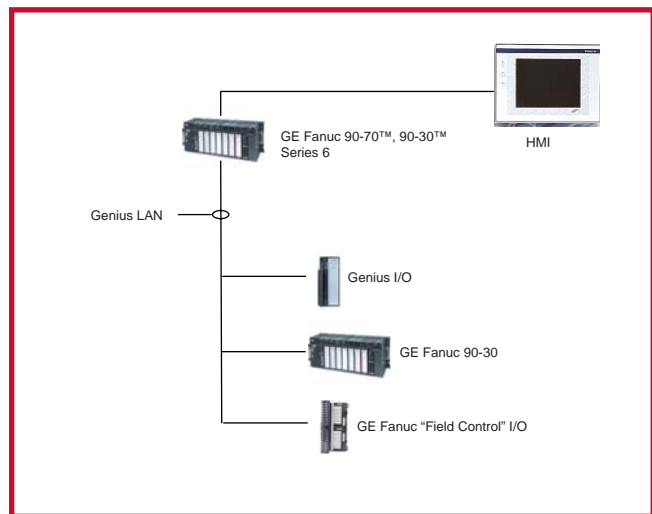

Legacy System

### ...TO HERE

- Component product backed by the outstanding support of Rockwell Automation.
- Open, integrated architecture for increased flexibility
- Re-use of engineering practices to reduce development time and costs
- Maximizing returns from existing assets through greatly improved control and monitoring
- Quickest response to customer or market demands
- Easy access to plant and production data from business systems for better management decision making
- Single environment for integrated motion, process and safety control

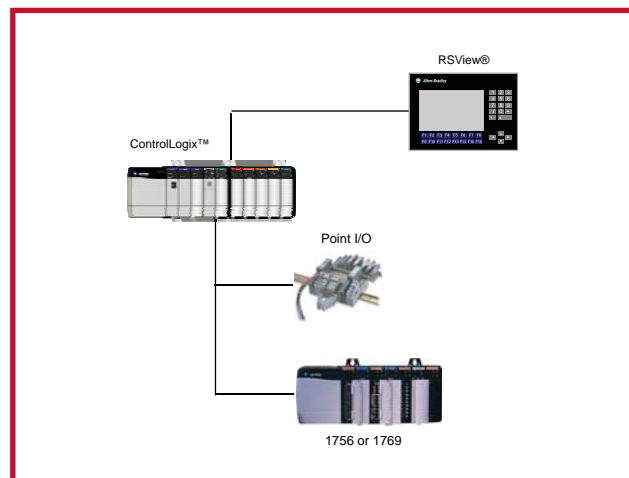

Integrated Architecture



WE HAVE A PLAN

# ALL AT ONCE OR STEP-BY-STEP

## STEP 1. OPERATOR INTERFACE REPLACEMENTS

Graphic Conversion Utilities not only make operator interface conversion much more cost effective, but give you greater flexibility regarding the final product. This means that you can account for how operators use your equipment and design interfaces that help maximize their productivity. In the end, this will allow you to give your operators the tools they need to get quality product to your customers.

## STEP 2. REPLACE LEGACY CONTROLLERS

Utilizing our network interface approach, you can replace your current Modicon controller without initially replacing your existing I/O. Our logic and Tag Database conversion utilities will help you quickly upgrade your programming logic allowing you to take full advantage of a new Rockwell Automation Logix controller. You can do this in “monitor mode,” allowing us to test code before you switch out the controller, all the while continuing production. This means you not only save money, but will be better positioned for both your current and future production demands.

## STEP 3. I/O REPLACEMENT (DO IT ALL OR ONE RACK AT A TIME)

I/O cross reference documentation assures correctness and provides historical back-up for future troubleshooting or diagnostics. I/O replacement represents a large investment, but our approach lets you replace by individual section or all at once. In either case, you can run both new and old I/O networks simultaneously. Whatever's right for you and your budget.

## STEP 4. OTHER ENHANCEMENTS THAT WOULD INCREASE THE PERFORMANCE OR MAINTAINABILITY OF YOUR EQUIPMENT

Because Rockwell Automation is a comprehensive supplier, we can help in other areas as well. We carry everything from sensors to motor control centers, so we can discuss all your needs. But it does not stop there. We have a worldwide service group that can do the migration, assist and train your operators or provide the maintenance services once it's complete. We can also review your network needs and review asset management for your entire plant.

Rockwell Automation provides many migration options. If you want or need to upgrade your systems all at once, we have the expertise and resources to get the job done quickly to minimize your potential loss of production. If you want to schedule migration service over time, we will work with you to create a plan that fits both your schedule and budget. In the end, we work with you to ensure that your migration investments better serve your customers and return a profit. Rockwell Automation not only has the product service, but the industry knowledge to make sure your new equipment does what it's supposed to do - make you money.

All trademarks and registered trademarks are the property of their respective companies.

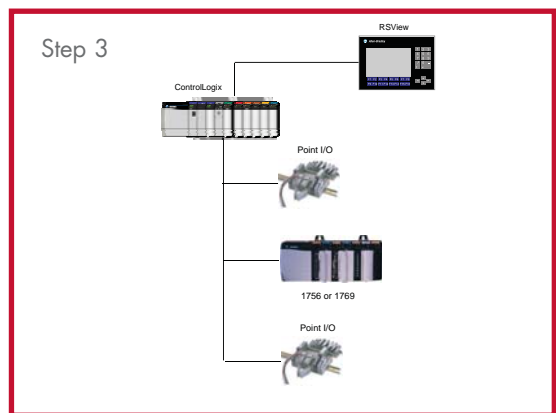
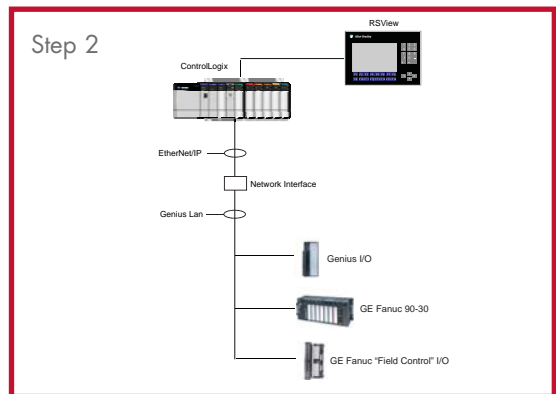
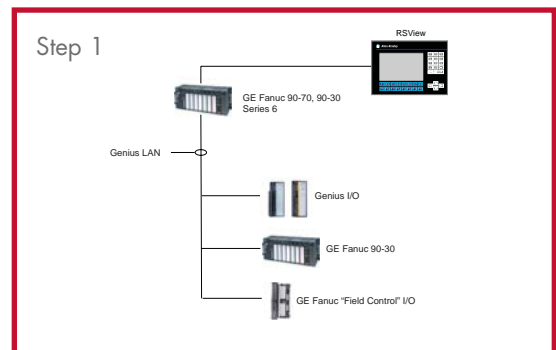

LISTEN. THINK. SOLVE. <sup>SM</sup>

**Rockwell  
Automation**