

MSR23M Minotaur Pressure Sensitive Safety Mat Module Installation Instructions

Original instructions in English



IMPORTANT

SAVE THESE INSTRUCTIONS FOR FUTURE USE.

- According to EU directive for machines 98/37/EG
- According to IEC 204-1, EN 60 204-1, DIN VDE 0113-1, EN 954-1
- Safety-mat module with manual or automatic reset
- Also used for safety edges (four-wire non-resistive type)
- Safety category 4 according to DIN EN 954-1
- Output: 2 N.O. + 1 N.C. contacts
- Monitoring of reset-button function
- Manual reset or automatic reset when connecting the supply voltage, switch S1
- LED indicator for state of operation
- Indicator for status of switching element
- LED indicator for channel 1 and 2
- Removable terminal strips
- Wire connection: also 2 x 1.5 mm² stranded ferruled (isolated), DIN 46 228-4 or 2 x 2.5 mm² stranded ferruled DIN 46 228-1/-1/-3
- Width 22.5 mm (0.88 in.)

Approvals



Applications

Control unit for safety mats and safety edges (4-wire nonresistive type)

Indicators

Upper LED	ON when supply connected
Lower LEDs	ON when relay K1 and K2 energized

Notes

Monitoring of Reset-button function:

Monitoring of Reset-button function is only active when S12 and S22 are switched simultaneously. If the Reset-button is closed before S12, S22 is connected to voltage (also when fault across Reset-Button), the output contacts will not close.

A fault across the Reset-button which occurred after activation of the relay, will be detected with the next activation and the output contacts will not close. If a fault occurs after the voltage has been connected to S12, S22, the unit will be activated because this fault is similar to the normal Reset-function. The gold plated contacts of the MSR23M mean that this module is also suitable for switching small loads of 1 mVA - 7 VA, 1 mW - 7 W in the range 0,1 - 60 V, 1 - 300 mA. The contacts also permit the maximum switching current. However since the gold plating will be burnt off at this current level, the device is no longer suitable for switching small loads after this.

Specifications

Input Circuit	440R-P23073	440R-P23074
Nominal voltage U _N :	24V DC	110V AC
Voltage range	DC	AC
DC: at 10% residual ripple	0.9...1.1 U _N	0.95...1.1 U _N
DC: at 48% Residual ripple	0.8...1.1 U _N	0.8...1.1 U _N
AC:	—	0.8...1.1 U _N
Nominal consumption	DC approx. 2 W	
Min. Off-time	1 s	
Control voltage on S11:	approx. DC 23V at U _N	
Cross fault current between line S11-S12 and line S21-S22 with active safety mat or safety edge start-up:	max. 0.4 A for approx. 2 ms continuously	
DC:	approx. 29 mA at U _N	
AC:	approx. 37 mA at U _N	
Control current over S12, S22	40 mA at U _N	
Min. voltage on S12, S22	DC 21 V when relay activated	
Short-circuit protection	Internal PTC	
Overvoltage protection	Internal VDR	
Output		
Contacts	2 N.O., 1 N.C.	
Operate delay typ. at U _N		
Manual start	40 ms	
Automatic start	200 ms	
Release delay typ. at U _N :		
Disconnecting the supply	50 ms	
Disconnecting S12, S22	15 ms	
Contact type	positive guided	
Nominal output voltage	250V AC DC: see limit curve for arc-free operation	
Switching of low loads (contact 5' Au)	≥100 mV ≥1 mA	
Thermal current I _{th} on 1 contact path on more than 1 contact path	see current limit curve max: 8 A max: 7 A per contact path	
Switching capacity to AC 15	AC 3 A/230V for N.O. contact AC 2 A/230 V for N.C. contact	EN 60 947-5-1 for N.O. contacts EN 60 947-5-1 for N.O. contacts
Electrical contact life to AC 15 at 2 A, AC 230V	10 ⁵ switching cycles	EN 60 947-5-1
Permissible operating frequency	1,200 operating cycles/h, max.	
Short circuit strength fuse rating, max. line circuit breaker:	6 A gL C 8 A	EN 60 947-5-1
Mechanical life	10 x 10 ⁶ switching cycles	

Specifications (continued)

General Data		
Operating mode	Continuous operation	
Temperature range [C (F)]	-15...+55 (5...+131)	
Clearance and creepage distances Overvoltage category/contamination level	4 kV/2	DIN VDE 0110-1 (04.97)
EMC Electrostatic discharge: HRF irradiation Fast transients Surge voltages between wires for power supply between wire and ground interference suppression	8 kV (air) 10 V/m 2 kV 1 kV 2 kV Limit value class B	EN 61 000-4-2 EN 61 000-4-3 EN 61 000-4-4 EN 61 000-4-5 EN 61 000-4-5 EN 55 011
Degree of protection	Housing: IP40 Terminals: IP20	EN 60 529 EN 60 529
Housing	Thermoplastic with V0 behavior according to UL subject 94	
Vibration resistance	Amplitude 0.35 mm frequency 10...55 Hz	EN 60 068-2-6
Climate resistance	15/05/04	EN 60-068-1
Terminal designation	EN 50 005	
Wire connection	1 x 4 mm ² solid or 1 x 2.5 mm ² stranded ferruled (isolated) or 2 x 1.5 mm ² stranded ferruled (isolated) DIN 46 228-1/-2/-3/-4 or 2 x 2.5 mm ² stranded ferruled DIN 46 228-1/-2/-3	
Wire fixing	Box terminal with wire protection, removable terminal strips	
Mounting	DIN rail	EN 50 022
Weight	220 g (7.76 oz)	
Dimensions		
Width x height x depth [mm (in.)]	22.5 x 84 x 118 (0.88 x 3.3 x 4.64)	

Dimensions [mm (in.)]

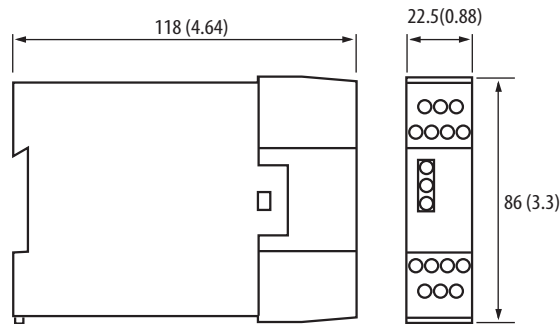

Cat. No. 440R-P23073—24V DC supply



Cat. No. 440R-P23074—110V AC supply

Function Diagram

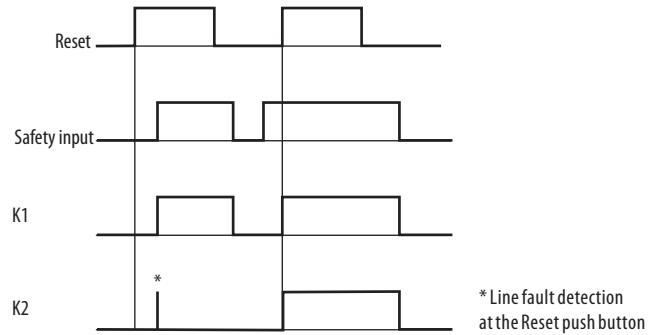

Block Diagram

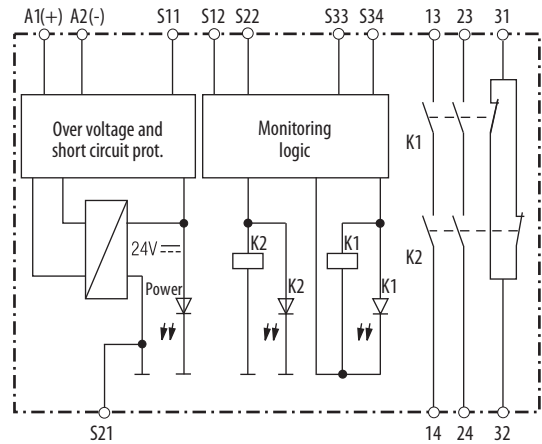

Circuit Diagrams

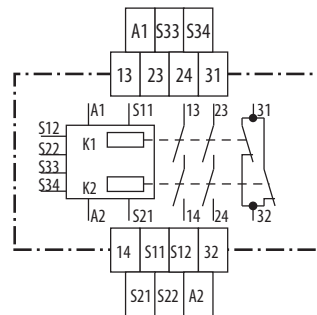

Cat. No. 440R-P23073—24V DC supply

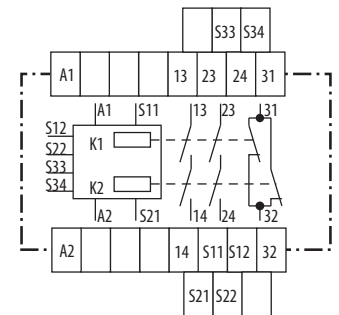

Cat. No. 440R-P23074—110V AC supply

Unit Programming

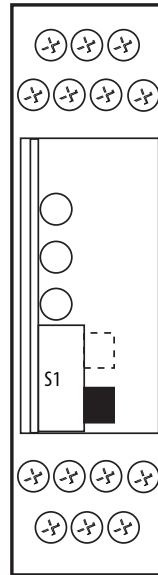
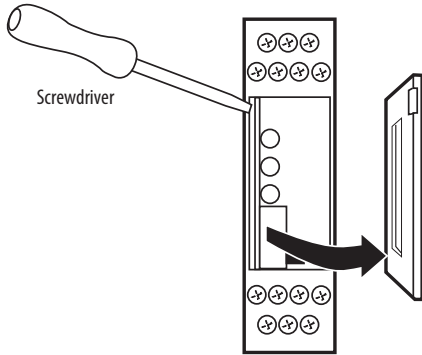

Drawing shows setting at the state of delivery
Disconnect unit before setting

Switch S1
Upper position for Auto reset.
Lower position for Manual reset.

IMPORTANT

Connecting the terminal S21 to the protective ground bridges the internal short-circuit protection of Line A2 (-). The short-circuit protection of line A1 (+) remains active. Depending on the operation of the machine, the switch S1 is set to automatic or manual restart.

Characteristics

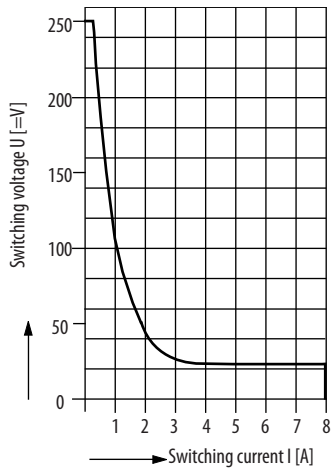

----- safe braking, no continuous arcing
max 1 switching cycle/s

Arc Limit Curve Under Resistive Load

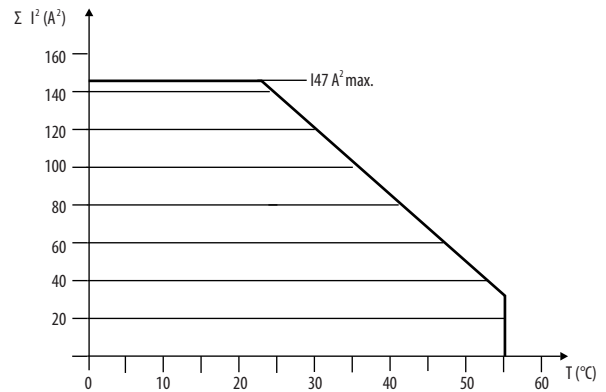

Quadratic total current

$$\Sigma I^2 = I_1^2 + I_2^2 + I_3^2$$

I_1, I_2, I_3 — current in contact paths

Quadratic Total Current Limit Curve

Application Examples

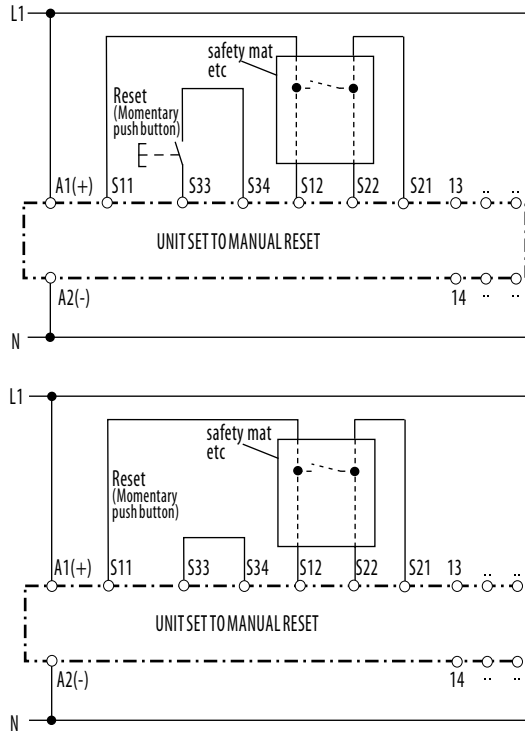

Declaration of Conformity

This is to declare that the MSR23 conforms with the Essential Health & Safety Requirements (EHSR's) of the European Machinery Directive (98/37/EC), the relevant requirements of the Low Voltage Directive (73/23/EEC as amended by 93/68 EEC) and the essential protection requirements of the EMC Directive (89/336/EEC as amended by 92/31 EEC). The MSR23 also conforms to EN 292, EN 60204-1, EN 954-1, UL 508.

Repair

If there is any malfunction or damage, no attempts should be made to repair it. The unit should be replaced before machine operation is allowed. DO NOT DISMANTLE THE UNIT.

Rockwell Automation maintains current product environmental information on its website at <http://www.rockwellautomation.com/rockwellautomation/about-us/sustainability-ethics/product-environmental-compliance.page>

Allen-Bradley, Guardmaster, and Rockwell Automation are trademarks of Rockwell Automation, Inc. Trademarks not belonging to Rockwell Automation are property of their respective companies.

www.rockwellautomation.com

Power, Control and Information Solutions Headquarters

Americas: Rockwell Automation, 1201 South Second Street, Milwaukee, WI 53204-2496 USA, Tel: (1) 414.382.2000, Fax: (1) 414.382.4444

Europe/Middle East/Africa: Rockwell Automation NV, Pegasus Park, De Kleetlaan 12a, 1831 Diegem, Belgium, Tel: (32) 2 663 0600, Fax: (32) 2 663 0640

Asia Pacific: Rockwell Automation, Level 14, Core F, Cyberport 3, 100 Cyberport Road, Hong Kong, Tel: (852) 2887 4788, Fax: (852) 2508 1846