

# Guardmaster® UNIVERSAL Isomag 4 GUARD SAFETY SWITCH

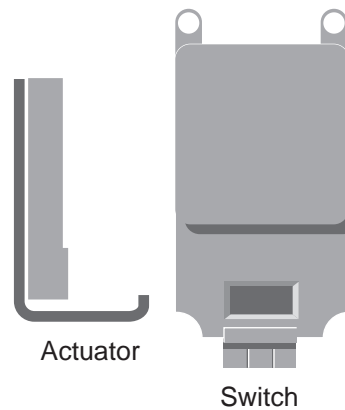

## INSTALLATION INSTRUCTIONS

Follow steps 1 to 7 for correct installation.

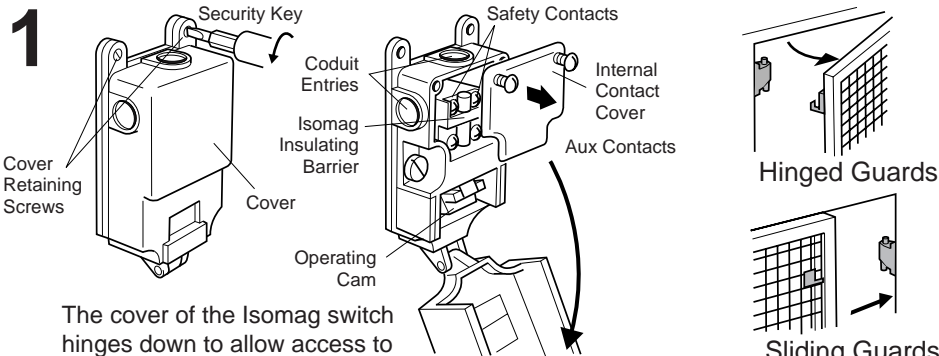

The cover of the Isomag switch hinges down to allow access to the fixing holes. Unscrew the 2 cover retaining screws using the security key supplied and swing down the cover. The internal plastic cover protects the electrical contacts and the ISOMAG Insulating Barrier. The ISOMAG 4 can be fitted in any position on hinged, sliding or lift-off guards.

2 The switch will accommodate inaccuracies in the guard or door but it should not be used as a guide. When correctly installed the bottom of the actuator tongue should clear the entry hole by 1mm. When the guard is closed there should be a gap of 3 to 6mm between the actuator and switch faces.

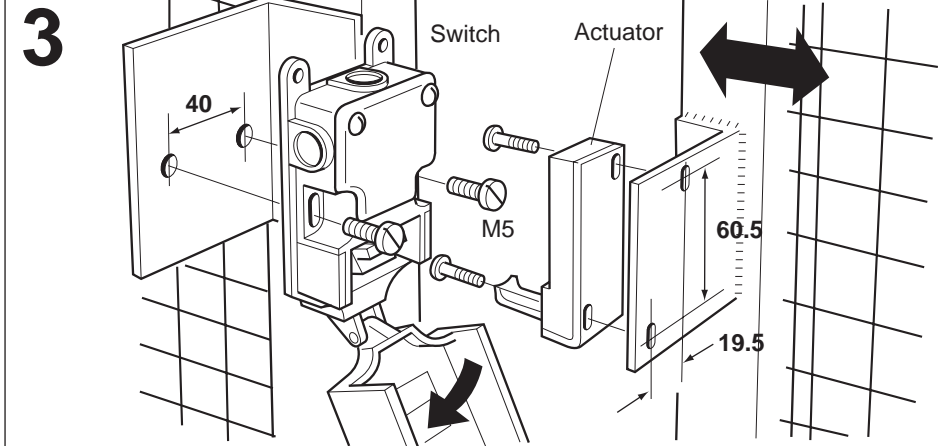
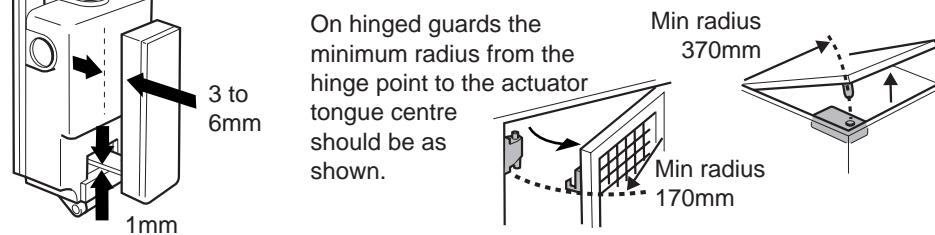

Hinge down the cover to gain access to the mounting holes. Mount the switch on the stationary section of the guard using 2 x M5 fixings. Use mounting brackets if necessary. Mount the actuator on the moving guard section with the actuator tongue centrally opposite the switch entry hole. Use the two security screws provided. The elongated holes allow adjustment before fully tightening the screws.

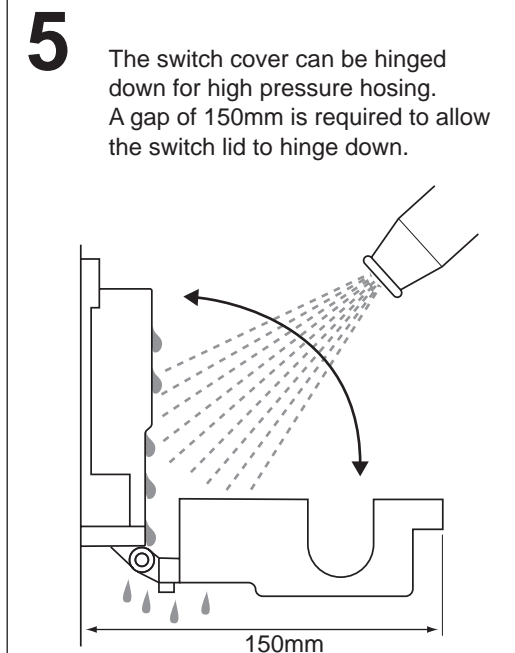
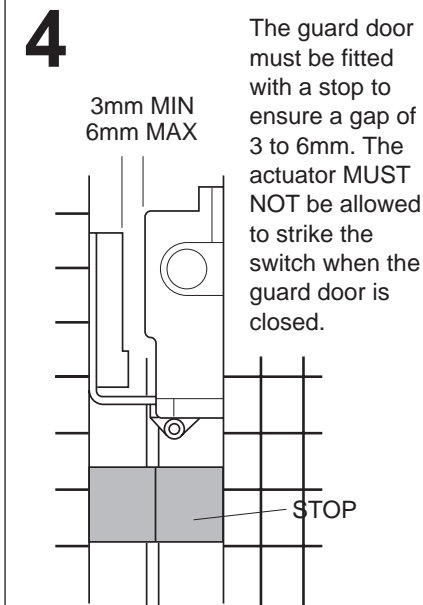

6

Remove the internal cover and connect the contact terminals as shown. Use the most convenient of the 3 knock out conduit entry points.

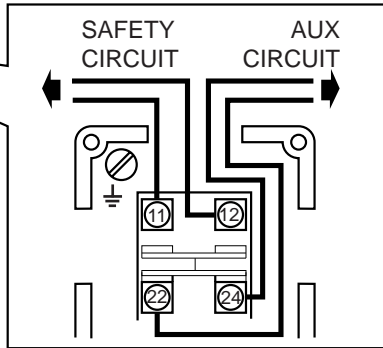
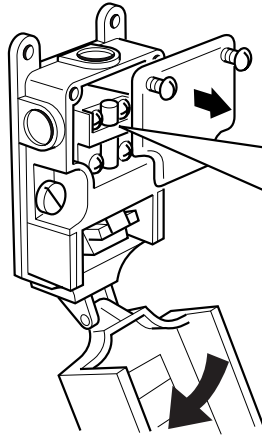

## TECHNICAL SPECIFICATIONS

Safety contacts: **Double positive break, N/O, AC11 500V 1A**  
 250V 2A  
 100V 5A  
**DC11 240V 0.5A**

Safety contact gap: **> 2 x 2.6mm.**

Auxiliary contacts: **Double positive break, N/C, AC11 500V 1A**  
 250V 2A  
 100V 5A  
**DC11 240V 0.5A**

Case: **Heavy duty die cast alloy, epoxy coated, colour red.**

Switch interior: **Glass reinforced nylon, self extinguishing.**

Protection: **IP66.**

Mounting: **Any position.**

Fixing: **2 x M5.**

Cover screws: **Resistorx anti-tamper.**

Cleaning: **May be steam cleaned or high pressure hosed.**

Operating temperature: **-35°C to +80°C.**

Operating life: **> 10 x 10<sup>6</sup>**

Conduit entries: **3 x BS20mm**

Actuator: **Pressed steel, chrome plated. Magnet housing moulded ABS.**

Fixing: **2 x M4 Resistorx anti-tamper (supplied).**

7

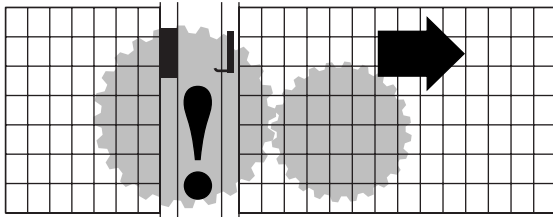

After installation check all of the interlocked guard doors to ensure that the machine is isolated and stopped before the guard has been opened a sufficient distance to allow access to the hazardous area.

## DIMENSIONS

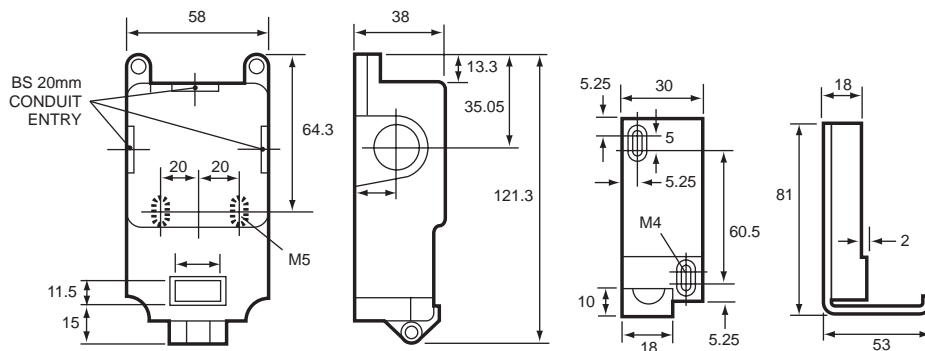

## ACCESSORIES

The Isomag 4 is available with alternative PG11 conduit threads.

Spare Actuator

Stuffing Gland - BS20mm

Stuffing Gland - PG11

Conduit Beacon - Indicator light (supplied without bulb) fits in spare conduit entry hole

Bulb for above - 24V, 110V, 240V (specify voltage)

Security Key

Screwdriver (inc. security key)



**Allen-Bradley**

**Guardmaster®**

Drg no. 10506/0