



## SD3000 PLUS DC Drive Regulator

### Class 1 LED Product



**ATTENTION:** Hazard of permanent eye damage exists when using optical transmission equipment. This product emits intense light and invisible radiation. Do not look into module ports or fiber optic cable connectors.

---



**ATTENTION:** Energized industrial control equipment can be hazardous. Severe injury or death can result from electrical shock, burn, or unintended actuation of controlled equipment. Hazardous voltages may exist in the cabinet even with the circuit breaker in the off position. Recommended practice is to disconnect and lock out control equipment from power sources, and discharge stored energy in capacitors, if present. If it is necessary to work in the vicinity of energized equipment, the Safety Related Practices of NFPA 70E, “ELECTRICAL SAFETY FOR EMPLOYEE WORKPLACES” must be followed. DO NOT work alone on energized equipment!



**ATTENTION:** The installation of the drive must be planned such that all cutting, drilling, tapping and welding can be accomplished with the drive removed from the enclosure. The drive is of the open type construction and any metal debris must be kept from falling into the drive. Metal debris or other foreign matter may become lodged in the drive circuitry resulting in component damage.



**ATTENTION:** An incorrectly applied or installed drive can result in component damage or a reduction in product life. Wiring or application errors, such as, undersizing the motor, incorrect or inadequate AC supply, or excessive ambient temperatures may result in malfunction of the system.



**ATTENTION:** Only qualified personnel familiar with DC drives and associated machinery should plan or implement the installation, start-up and subsequent maintenance of the system. Failure to comply may result in personal injury and/or equipment damage.

---



**ATTENTION:** This drive regulator contains ESD (Electrostatic Discharge) sensitive parts and assemblies. Static control precautions are required when installing, testing, servicing or repairing this assembly. Component damage may result if ESD control procedures are not followed. If you are not familiar with static control procedures, reference A-B publication 8000-4.5.2, “Guarding Against Electrostatic Damage” or any other applicable ESD protection handbook.

**Minimum Mounting Clearances**

Mount the SD3000 PLUS in a clean, dry location. Contamination from oils, corrosive vapors and abrasive debris must be kept out of the enclosure.

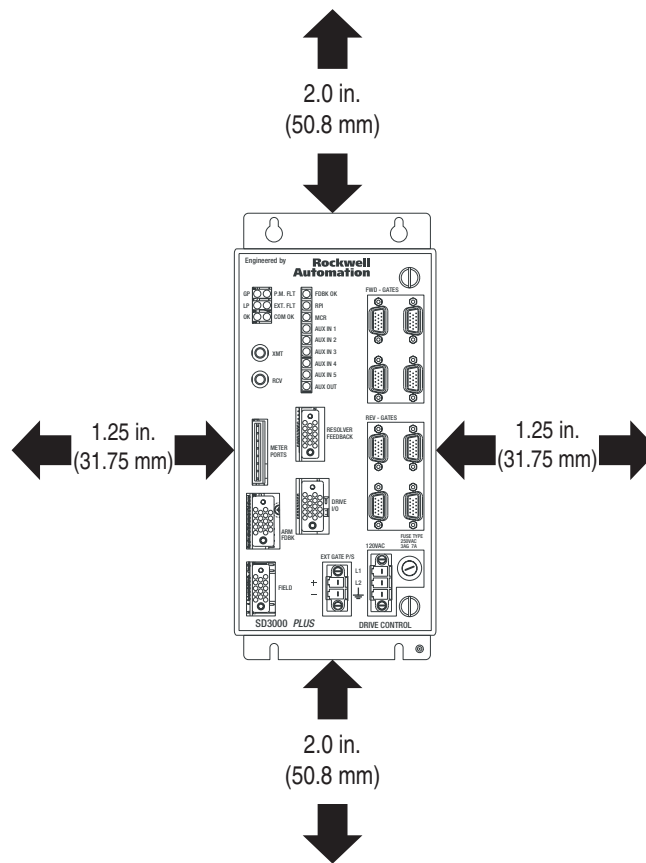

- Do not mount heat-generating equipment underneath the unit
- Mount the unit in a vertical position only

**Operating Temperatures**

The surrounding air temperature must be within 0 °C to 50 °C (32 °F to 122 °F).

## Dimensions

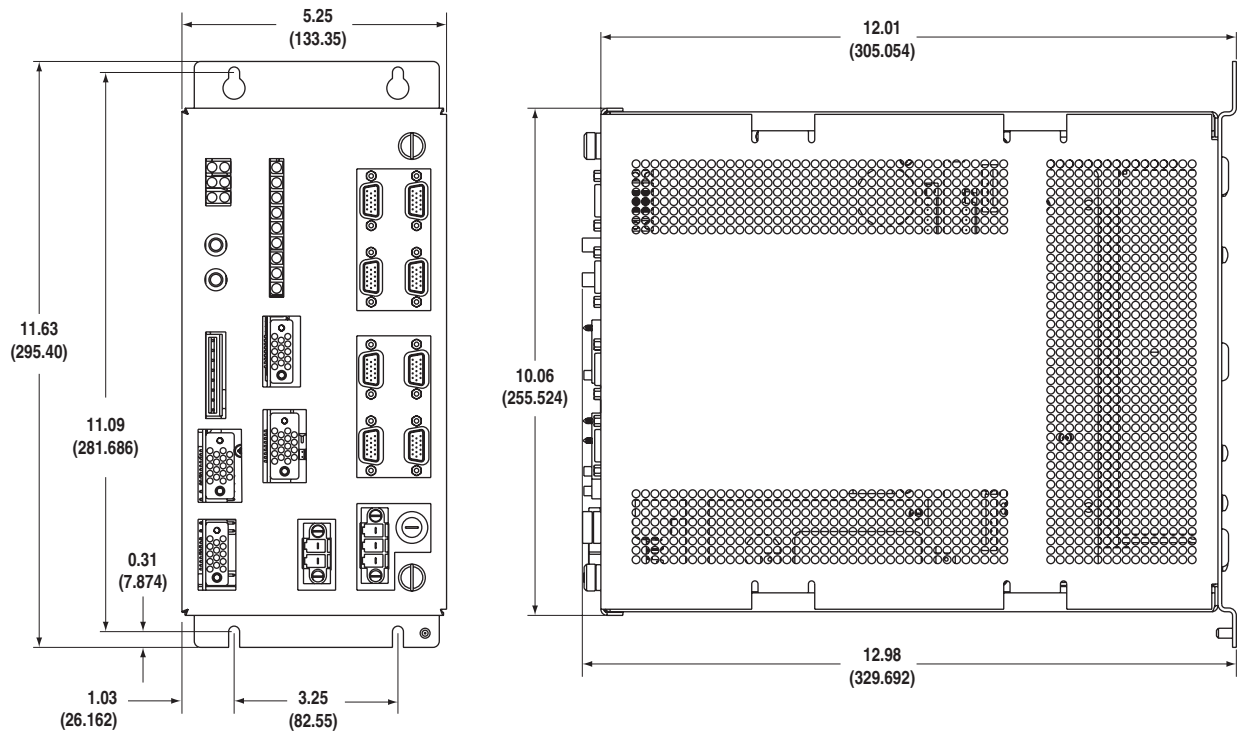

*Dimensions are in inches and (millimeters).*

<b>Weight kg (lbs.)</b>	
<b>Drive Regulator</b>	<b>Drive Regulator &amp; Packaging</b>
7.03 (15.5)	7.71 (17.0)

**Important:** Allow at least 4.5 inches (114.3 mm) for connectors and cable bend radius in front of unit.

## Connecting Power Wiring and Grounding

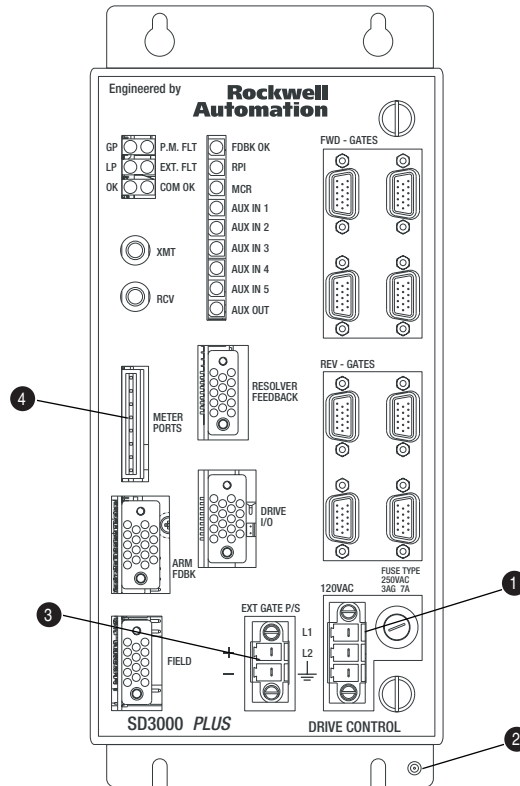

**Table 1.A Terminal Specifications**

No.	Name	Description	Part Number for Customer Plug (provided with SD3000 PLUS)	Wire Size Range		Torque
				Maximum	Minimum	Recommended
1	Input Power Terminal Block L1, L2, Ground	Input power	94809302	4.0 mm <sup>2</sup> (10 AWG)	2.5 mm <sup>2</sup> (14 AWG)	0.677909 N-m (6 lb.-in.)
2	Ground Stud	Chassis Ground	Use grounding cable kit 97297501 provided with regulator			
3	External Gate Power Supply	External Gate Power Supply (if used)	94809301	10 AWG, Twisted Pair, 2 Twists / in.	18 AWG, Twisted Pair, 2 Twists / in.	0.677909 N-m (6 lb.-in.)
4	Meter Ports	Meter Port Output	49455-115H	14 AWG, Twisted Pair, 2 Twists / in. 13feet (4m) max. length	22 AWG, Twisted Pair, 2 Twists / in. 13feet (4m) max. length	0.677909 N-m (6 lb.-in.)

## Connecting Control Wiring Class 1 LED Product



**ATTENTION:** Hazard of permanent eye damage exists when using optical transmission equipment. This product emits intense light and invisible radiation. Do not look into module ports or fiber optic cable connectors.

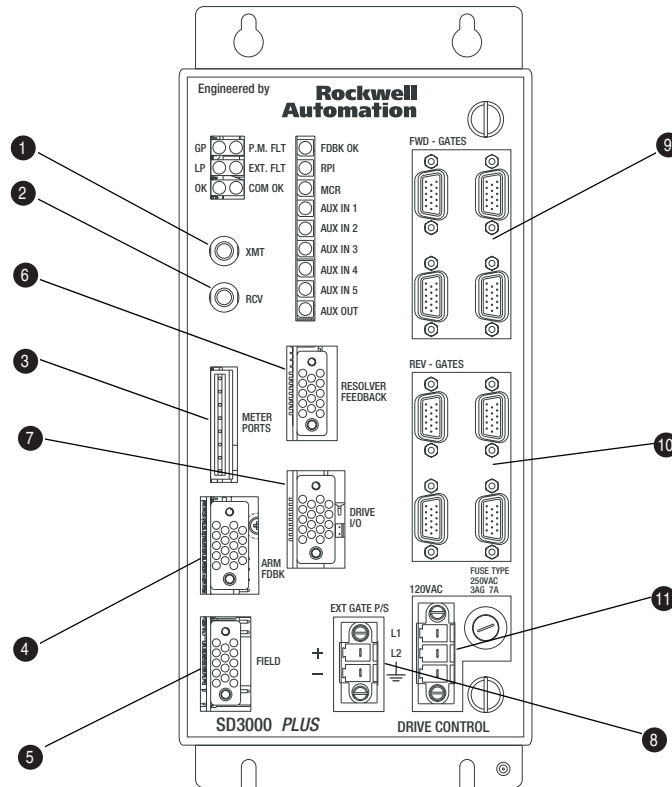

No.	Description	Connects to	Use Cable Number
1	XMIT – Fiber optic transmit port	The Drive Comm receive port on the 1756-DMD30, ControlLogix Drive Module	<ul style="list-style-type: none"> <li>1756-DMCF001 – 1 meter Drive Comm cable</li> <li>1756-DMCF003 – 3 meter Drive Comm cable</li> <li>1756-DMCF010 – 10 meter Drive Comm cable</li> <li>1756-DMCF030 – 30 meter Drive Comm cable</li> <li>1756-DMAF - adapter for existing UDC/PMI cable</li> </ul>
2	RCV - Fiber optic receive port	The Drive Comm transmit port on the 1756-DMD30, ControlLogix Drive Module	
3	METER PORTS – Four analog outputs for the monitor of internal registers	Analog meters or analog inputs of a monitoring device	14-22 AWG, twisted pair, 2 twists per inch.
4	ARM FDBK – Voltage, Current and Phasing feedback	Scaling Module, Current Transformers and Phasing Transformer	Cbl, Arm Fdbk/Pwr_Mod <ul style="list-style-type: none"> <li>SD3K-CBLSCLR048 – 4 foot length</li> <li>SD3K-CBLSCLR060 – 5 foot length</li> <li>SD3K-CBLSCLR096 – 8 foot length</li> </ul> (97305800 to view drawing for additional lengths)
5	FIELD – Field Gate signals and Current Feedback	Field Power Module	Cable,Fld Gate/Fdbk <ul style="list-style-type: none"> <li>SD3K-CBLFLD060 – 5 foot length</li> </ul> (97306200 to view drawing for additional lengths)
6	RESOLVER FEEDBACK – Resolver and One input for analog feedback (analog tachometer, if used or other analog signal)	Resolver, Analog Tachometer or other Analog source	Cable,Rslvr/Anlg, DIN TB <ul style="list-style-type: none"> <li>SD3K-CBLRSLVR060 – 5 foot length</li> <li>SD3K-CBLRSLVR096 – 8 foot length</li> </ul> (97305600 to view drawing for additional lengths)

No.	Description	Connects to	Use Cable Number
7	DRIVE I/O – 120VAC Drive Command / Control Inputs	<ul style="list-style-type: none"> <li>• RPI – Run Permissive Input</li> <li>• MCR – Output to control M Contactor</li> <li>• Auxiliary Input 1 – M Contactor feedback</li> <li>• Auxiliary Input 2 – Inverting fault circuit breaker (if circuit breaker is used)</li> <li>• Auxiliary Input 3 – Power module thermal interlock</li> <li>• Auxiliary Input 4 – Motor thermal switch</li> <li>• Auxiliary Input 5 – (spare)</li> </ul>	Cable, Drive I/O, DIN TB <ul style="list-style-type: none"> <li>• SD3K-CBLDRVIO060 – 5 foot length</li> <li>• SD3K-CBLDRVIO096 – 8 foot length</li> </ul> (97305700 to view drawing for additional lengths)
8	EXT GATE P/S – External Gate Power Supply	External Gate 48V Power Supply  Contact Development for interlocking guidelines	18 AWG minimum, twisted pair, 2 twists per inch
9	FWD GATES – Armature Forward Gates	Four forward gate outputs to provide gate signals for up to four power modules  All four outputs are identical	Cable, “Round Style” Connector, Fwd Gates <ul style="list-style-type: none"> <li>• SD3K-CBLFWDP060 – 5 foot length</li> <li>• SD3K-CBLFWDP120 – 10 foot length</li> <li>• SD3K-CBLFWDP180 – 15 foot length</li> <li>• SD3K-CBLFWDP240 – 20 foot length</li> </ul> (97305100 to view drawing for additional lengths)
10	REV GATES - Armature Reverse Gates	Four reverse gate outputs to provide gate signals for up to four power modules. All four outputs are identical	Cable, “Round Style” Connector, Rev Gates <ul style="list-style-type: none"> <li>• SD3K-CBLREVPM060 – 5 foot length</li> <li>• SD3K-CBLREVPM120 – 10 foot length</li> <li>• SD3K-CBLREVPM180 – 15 foot length</li> <li>• SD3K-CBLREVPM240 – 20 foot length</li> </ul> (97305300 to view drawing for additional lengths)
11	120VAC – Power input to regulator	Cabinet control power	10-14 AWG

*Note: Refer to part drawing for additional cable lengths.*

## Checking the Indicators

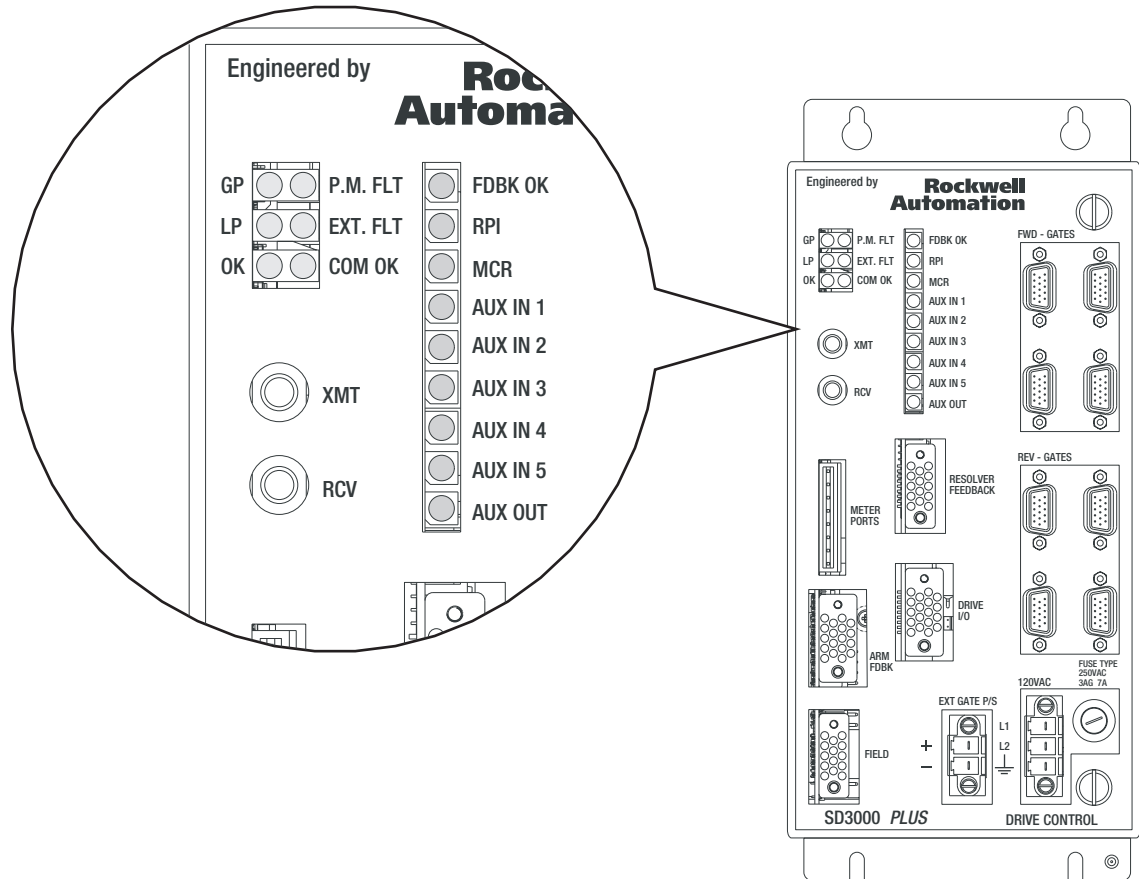

LED	Indicates
GP	Gate Power is present
LP	Logic Power is present
OK	The drive regulator has passed its internal power-up diagnostic tests. After power-up this LED will turn off if the internal "watchdog timer" fault occurs.
P.M. FLT	Shorted SCR, Field Current Feedback too low or too high.
EXT. FLT	Loss of AC Line Synchronization, AC Line Missing, Instantaneous Over-Current (IOC), Over-speed, User program has initiated the illumination of the LED.
COMM OK	Drive Comm is active and synchronized.
FDBK OK	The SD3000 Plus is receiving feedback from the resolver and no resolver feedback faults have been detected. If the LED is off, one of the following faults may have occurred: <ul style="list-style-type: none"> <li>Feedback Loss Fault - armature voltage has exceeded 40% of the rated value and speed feedback has been less than 5% of motor base speed</li> <li>Broken Wire Fault - a resolver sine or cosine signal is missing</li> </ul>
RPI	The Run Permissive Input (RPI) is energized.
AUX IN 1	Auxiliary Input 1 is energized. This input usually indicates the status of the M-Contactor.
AUX IN 2	Auxiliary Input 2 is energized. This input often indicates the status of an inverting fault circuit breaker.
AUX IN 3	Auxiliary Input 3 is energized. This input often indicates the status of the Power Module's airflow switch.
AUX IN 4	Auxiliary Input 4 is energized. This input often indicates the status of the motor thermal switch.
AUX IN 5	Auxiliary Input 5 is energized.
AUX OUT	Auxiliary Output is energized.

### Related Products and Documentation

Allen-Bradley and Reliance Electric publications are available on the internet at [www.rockwellautomation.com/literature](http://www.rockwellautomation.com/literature).

Catalog number:	Document title:	Pub. number:
1756-DM	ControlLogix Drive Module Installation Instructions	1756-IN577...
1756-DM	ControlLogix Drive Module User Manual (All Types)	1756-UM522...
1756-DMD30	Reference Manual - ControlLogix Drive Module (SD3000 Interface)	1756-RM088...

### Specifications

#### Electrical

Control Input                    120V ac ±10%, 2.2A, 47-63 Hz  
 Replacement fuse              Littelfuse 312007, 7Amp, 250 V ac, 3AG or equivalent.

#### Environmental

Operating Temperature        0 C to 50 C (32 F to 122 F)  
 Storage Temperature         -40 C to 70 C (-40 F to 158 F)  
 Relative Humidity              5% to 95%, Non-condensing

### Gate Hardware Overview

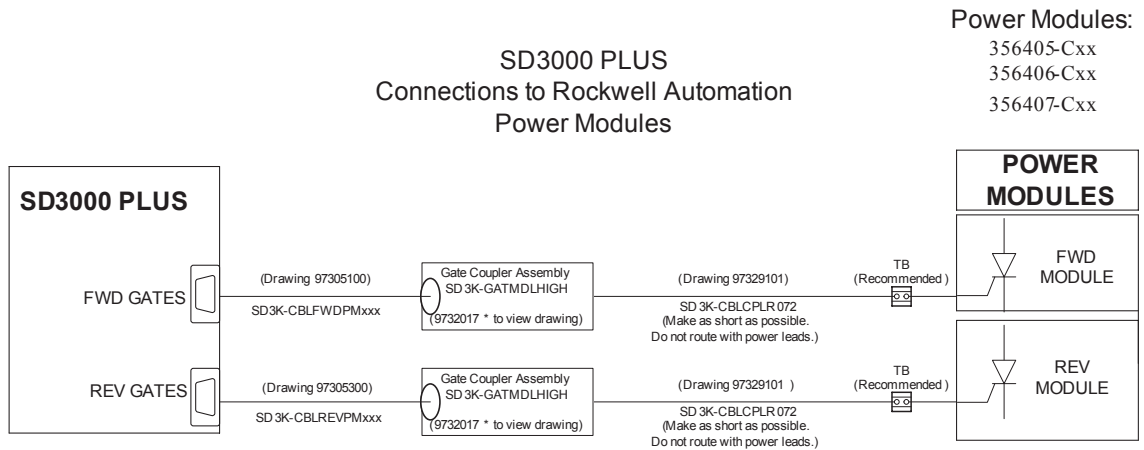



### SD3000 PLUS Retrofit of Non-Rockwell Power Module (S6R)

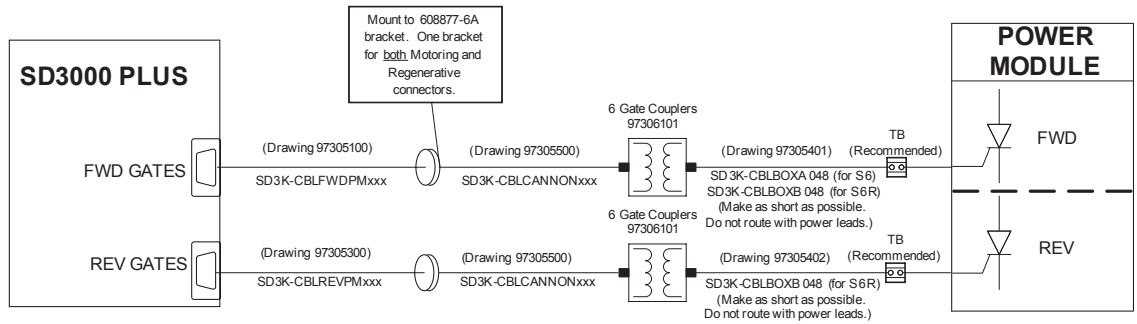

### SD3000 PLUS Retrofit of Non-Rockwell Power Module (S6R)

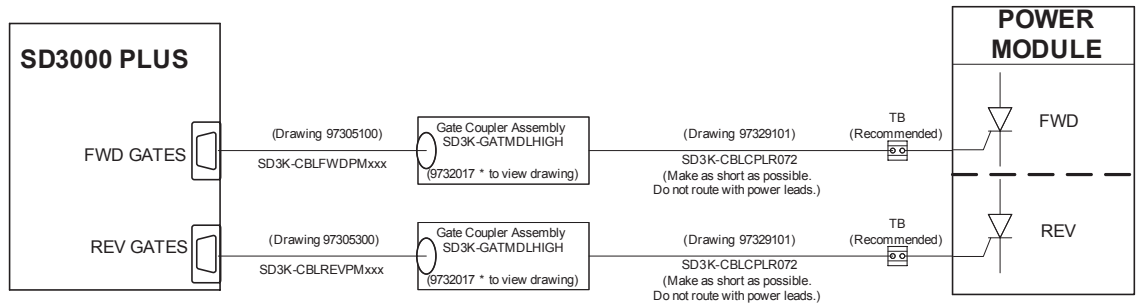

### SD3000 PLUS Retrofit of Reliance Power Module (S6R) With "round" style gate connector and With O-51378-19 (or equivalent) gate couplers.

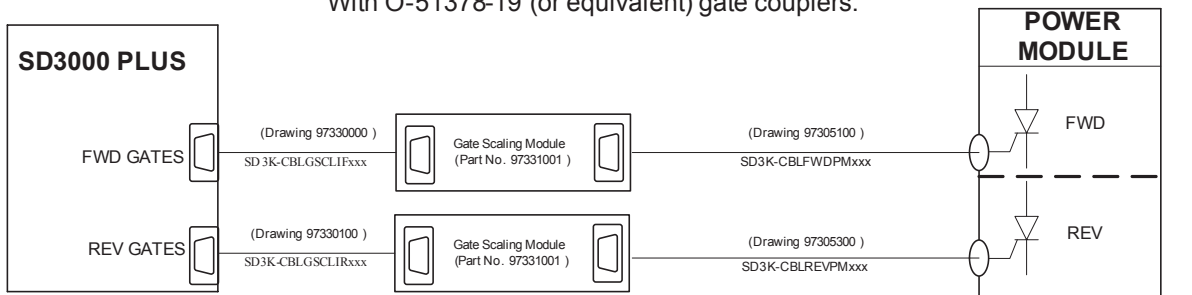

### Reliance Power Module (S6R)

**SD3000 PLUS**  
**Retrofit of Reliance Power Module (S6R)**  
**With Elco "rectangular" style gate connector and**  
**With O-51378-19 (or equivalent) gate couplers.**

**Reliance**  
**Power Module (S6R)**

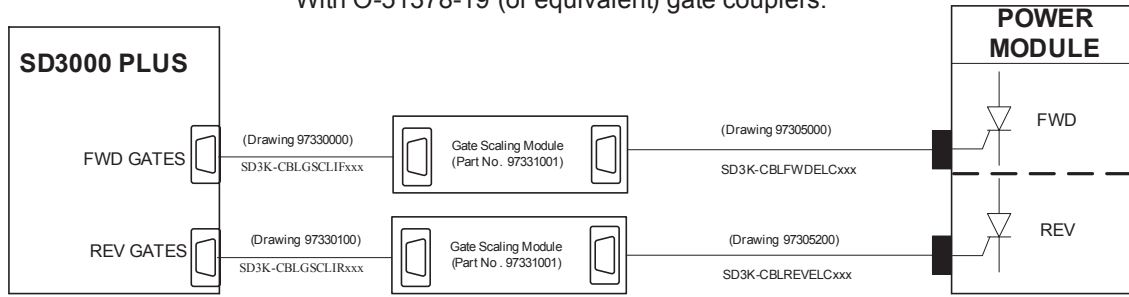

*Note: Dierikon power module gate coupling boards are compatible with the SD3000 Plus.*



[www.rockwellautomation.com](http://www.rockwellautomation.com)

**Power, Control and Information Solutions Headquarters**

Americas: Rockwell Automation, 1201 South Second Street, Milwaukee, WI 53204-2496 USA, Tel: (1) 414.382.2000, Fax: (1) 414.382.4444  
 Europe/Middle East/Africa: Rockwell Automation, Vorstlaan/Boulevard du Souverain 36, 1170 Brussels, Belgium, Tel: (32) 2 663 0600, Fax: (32) 2 663 0640  
 Asia Pacific: Rockwell Automation, Level 14, Core F, Cyberport 3, 100 Cyberport Road, Hong Kong, Tel: (852) 2887 4788, Fax: (852) 2508 1846