

# 16 Channel Analog Input Module

M/N 61C613

---

Instruction Manual J-3613-1

---

**RELIANCE**  
**ELECTRIC** 

The information in this user's manual is subject to change without notice.

**WARNING**

**THIS UNIT AND ITS ASSOCIATED EQUIPMENT MUST BE INSTALLED, ADJUSTED AND MAINTAINED BY QUALIFIED PERSONNEL WHO ARE FAMILIAR WITH THE CONSTRUCTION AND OPERATION OF ALL EQUIPMENT IN THE SYSTEM AND THE POTENTIAL HAZARDS INVOLVED. FAILURE TO OBSERVE THESE PRECAUTIONS COULD RESULT IN BODILY INJURY.**

**WARNING**

**INSERTING OR REMOVING THIS MODULE OR ITS CONNECTING CABLES MAY RESULT IN UNEXPECTED MACHINE MOTION. TURN OFF POWER TO THE MACHINE BEFORE INSERTING OR REMOVING THE MODULE OR ITS CONNECTING CABLES. FAILURE TO OBSERVE THESE PRECAUTIONS COULD RESULT IN BODILY INJURY.**

**CAUTION**

**THIS MODULE CONTAINS STATIC-SENSITIVE COMPONENTS. CARELESS HANDLING CAN CAUSE SEVERE DAMAGE.**

**DO NOT TOUCH THE CONNECTORS ON THE BACK OF THE MODULE. WHEN NOT IN USE, THE MODULE SHOULD BE STORED IN AN ANTI-STATIC BAG. THE PLASTIC COVER SHOULD NOT BE REMOVED. FAILURE TO OBSERVE THIS PRECAUTION COULD RESULT IN DAMAGE TO OR DESTRUCTION OF THE EQUIPMENT.**

ReSource<sup>™</sup> is a trademark of Reliance Electric Company.  
Reliance<sup>®</sup>, AutoMax<sup>®</sup> and AutoMate<sup>®</sup> are registered trademarks of  
Reliance Electric Company.

# Table of Contents

<b>1.0</b>	<b>Introduction</b>	<b>1-1</b>
<b>2.0</b>	<b>Mechanical/Electrical Description</b>	<b>2-1</b>
2.1	Mechanical Description	2-1
2.2	Electrical Description	2-3
<b>3.0</b>	<b>Installation</b>	<b>3-1</b>
3.1	Initial Installation	3-1
3.2	Module Replacement	3-4
<b>4.0</b>	<b>Programming</b>	<b>4-1</b>
4.1	Register Organization	4-1
4.2	Command Descriptions	4-2
4.2.1	Module Reset	4-2
4.2.2	Module Initialization	4-3
4.2.3	Write Channel Number	4-3
4.2.4	Configure Channel Input	4-4
4.2.5	Configure Channel Slope	4-5
4.2.6	Configure Channel Offset	4-5
4.2.7	Configure Scan Range for Continuous Mode	4-6
4.2.8	Read Analog Input in Continuous Scan Mode	4-6
4.2.9	Read Analog Input on Demand	4-7
4.3	Programming Examples	4-7
4.3.1	Writing Commands with the DCS 5000/AutoMax	4-7
4.3.2	Reading Data with the DCS 5000/AutoMax	4-8
4.3.3	Writing Commands with the AutoMate	4-9
4.3.4	Reading Data with the AutoMate	4-10
4.4	Restrictions	4-11
4.4.1	Rack Slot Location	4-11
4.4.2	Reading and Writing Data	4-11
<b>5.0</b>	<b>Diagnostics and Troubleshooting</b>	<b>5-1</b>
5.1	Incorrect Data	5-1
5.2	Bus Error	5-2

# Appendices

<b>Appendix A</b>	
Technical Specifications .....	A-1
<b>Appendix B</b>	
Module Block Diagram .....	B-1
<b>Appendix C</b>	
Module Connections .....	C-1
<b>Appendix D</b>	
Related Components .....	D-1
<b>Appendix E</b>	
Command Summary .....	E-1
<b>Appendix F</b>	
Error Codes .....	F-1
<b>Appendix G</b>	
AutoMate Program Setup Table .....	G-1
<b>Appendix H</b>	
AutoMate Program Command Register Table .....	H-1
<b>Appendix I</b>	
AutoMate Program Analog Input Table .....	I-1

# List of Figures

Figure 2.1 - Module Faceplate .....	2-2
Figure 2.2 - Typical Input Circuit .....	2-3

# List of Tables

Table 3.1 - AutoMate 30/40 Slot Configuration .....	3-1
Table 3.2 - DCS 5000 Slot Configuration .....	3-2
Table 4.1 - Memory Locations .....	4-2
Table 4.2 - Channel Signal Configuration .....	4-4



# 1.0 INTRODUCTION

The 61C613 is an input module for the AutoMate® 30/40 and DCS 5000/AutoMax™. It features 16 individually-isolated analog inputs capable of multiplexing signals from any combination of thermocouples and low or high level voltages, or RTDs. The module must be used in conjunction with either the 61C614 Thermocouple/Voltage Termination Panel, or the 61C615 RTD Termination Panel.

Two application programming disks are included with the input module. Both disks contain exactly the same programs. The programs allow you to verify the functionality of the module. The disks also include sample programs for reading inputs using the module.

The module provides automatic linearization and cold junction compensation for type B, E, J, K, R, and T thermocouples. Thermocouples may be read in either degrees Centigrade or Fahrenheit. Thermocouple inputs can be read as often as once every 110 msec. Thermocouple inputs require the use of the 61C614 Thermocouple/Voltage Termination Panel. The module can be used to convert signals from RTDs, using the 61C615 RTD Termination Panel. In this mode, the module must be configured for voltage inputs, typically  $\pm 1.25$  V.

The module provides offset and span compensation for voltage inputs. Voltages can range from a full scale of  $\pm 12.5$  mvolts up to a maximum of  $\pm 10.0$  volts. Voltages may be converted to either 12-bit precision every 45 msec. or 14-bit precision every 75 msec. Voltage inputs require the use of the 61C614 Termination panel.

This manual describes the functions and specifications of the input module. It also includes a detailed overview of installation and servicing procedures, as well as examples of programming methods.

Related publications that may be of interest:

- J-2605 AutoMate 30/40 PRODUCT SUMMARY
- J-3150 AutoMate 30/40 SOFTWARE INSTRUCTION MANUAL
- J-2611 DCS 5000 PRODUCT SUMMARY
- J-3675 DCS 5000 ENHANCED BASIC LANGUAGE INSTRUCTION MANUAL
- J-3676 DCS 5000 CONTROL BLOCK LANGUAGE INSTRUCTION MANUAL
- J-3630 RESOURCE™ AUTOMAX™ PROGRAMMING EXECUTIVE INSTRUCTION MANUAL
- J-3645-1 RTD TERMINATION PANEL INSTRUCTION MANUAL
- J-3646-1 THERMOCOUPLE/VOLTAGE TERMINATION PANEL INSTRUCTION MANUAL
- IEEE 518 GUIDE FOR THE INSTALLATION OF ELECTRICAL EQUIPMENT TO MINIMIZE ELECTRICAL NOISE INPUTS TO CONTROLLERS FROM EXTERNAL SOURCES





## **2.0 MECHANICAL/ELECTRICAL DESCRIPTION**

The following is a description of the faceplate, field termination connectors, and electrical characteristics of the field connections.

### **2.1 Mechanical Description**

The input module is a printed circuit board assembly that plugs into the backplane of the AutoMate or DCS 5000/AutoMax rack. It consists of a printed circuit board, a faceplate, and a protective enclosure. The faceplate contains tabs at the top and bottom to simplify removing the module from the rack. Module dimensions are listed in Appendix A. See figure 2.1 for the module faceplate.

The faceplate of the module contains three male connector sockets. Only the middle and lower connectors are used. Input signals are brought into the module via two 50-wire flat cables. One end of the cable attaches to the faceplate connector, while the other end of the cable attaches to the field termination panel (M/N 61C614 or M/N 61C615) for easy field wiring.

On the back of the module are two edge connectors that attach to the system backplane.

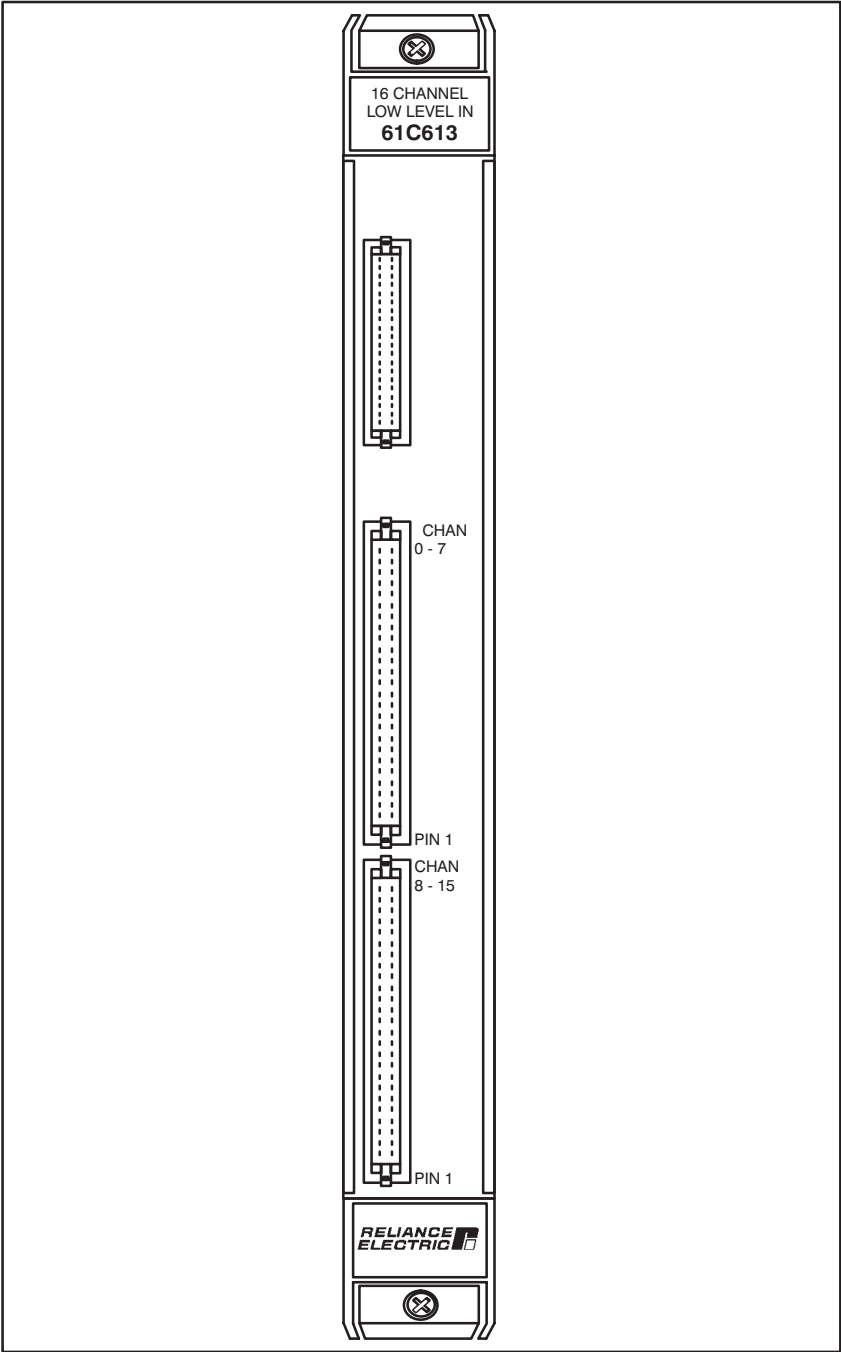

Figure 2.1- Module Faceplate

## 2.2 Electrical Description

The input module contains sixteen analog input channels with software-selectable features. These channels are connected through a multiplexer to a dual-slope integrating A/D converter. Each analog input channel has 200 volt channel-to-channel isolation and 1000 volt isolation to logic common. Each channel may be independently configured to accept voltages ranging from  $\pm 12.5$  mVolts through  $\pm 10.0$  Volts. Refer to figure 2.2 for a typical input circuit.

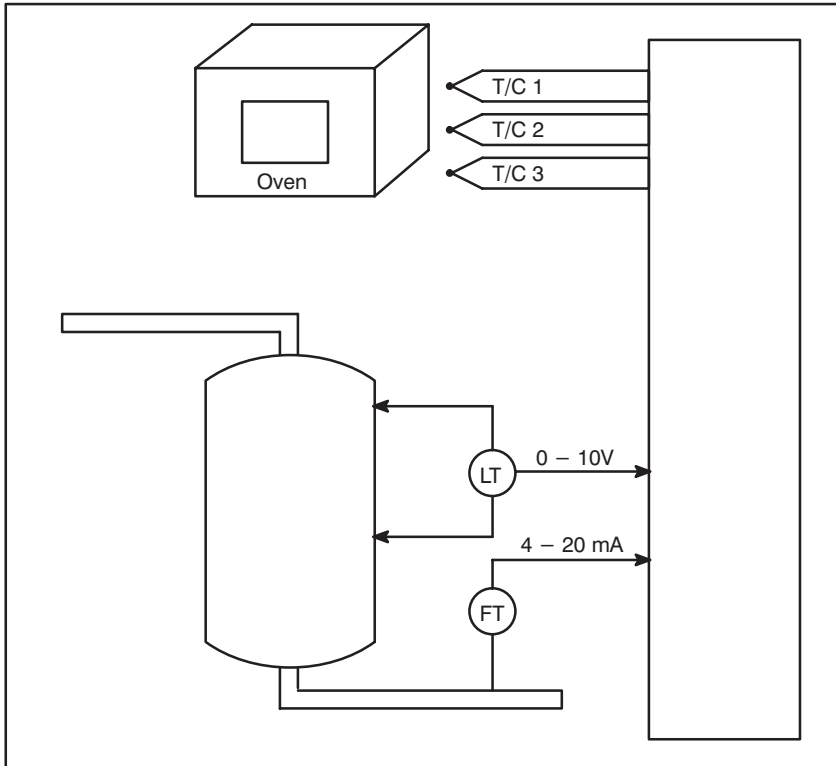

Figure 2.2- Typical Input Circuit

An on-board micro-processor controls the analog/digital conversion. A simple bus interface allows your application software to send/receive commands to the module.



# 3.0 INSTALLATION

This section describes how to install and remove the module and its cable assembly.

## 3.1 Initial Installation

Use the following procedure to install the module:

- Step 1. Turn off power to the system. All power to the rack as well as all power to the wiring leading to the rack should be off.
- Step 2. Mount the proper termination panel (61C614 or 61C615). Refer to the Thermocouple/Voltage Termination Panel Instruction Manual (J-3646-1) or the RTD Termination Panel Instruction Manual (J-3645-1) for specific information.
- Step 3. Set the address jumpers on the module for the slot in which the module will be located. The address jumpers are located on switch S1. Refer to table 3.1 for the AutoMate 30/40 and table 3.2 for the DCS 5000/AutoMax. Note that the slot numbers correspond to actual rack slot numbers.

If you are using a DCS rack and you are also using a micro-regulator in that rack, there is an important restriction on the slots the input module may occupy. The micro-regulator may be placed only in slots that fall in two groups: 5 through 8, and 11 through 14. The 61C613 may not occupy a slot in a group that contains a micro-regulator.

Table 3.1- AutoMate 30/40 Slot Configuration

Slot #	1	2	3	4	5	6	7	10	11	12	13	14	15	16	17	0
base address (HEX)	1	2	3	4	5	6	7	8	9	A	B	C	D	E	F	0
	0	0	0	0	0	0	0	0	0	0	0	0	0	0	0	0
	0	0	0	0	0	0	0	0	0	0	0	0	0	0	0	0
	0	0	0	0	0	0	0	0	0	0	0	0	0	0	0	0
	0	0	0	0	0	0	0	0	0	0	0	0	0	0	0	0
Switch																
S1-1								●	●	●	●	●	●	●	●	
S1-2				●	●	●	●					●	●	●	●	
S1-3		●	●			●	●			●	●			●	●	
S1-4	●		●		●		●		●		●		●		●	
S1-5																
S1-6																
S1-7																
S1-8																

● = Switch is closed

Table 3.2- DCS 5000 Slot Configuration

Slot #	0	1	2	3	4	5	6	7	8	9	10	11	12	13	14	15
base address (HEX)	—	—	20000	23000	24000	25000	26000	27000	28000	29000	2A000	2B000	2C000	2D000	2E000	2F000
Switch																
S1-1	—	—														
S1-2	—	—														
S1-3	—	—														
S1-4	—	—														
S1-5	—	—							●	●	●	●	●	●	●	●
S1-6	—	—			●	●	●	●					●	●	●	●
S1-7	—	—	●	●			●	●			●	●			●	●
S1-8	—	—		●		●		●		●		●		●		●

● = Switch is closed  
 — = illegal slot

- Step 4. Insert the module into the desired slot in the rack. Use a screwdriver to secure the module into the slot.
- Step 5. Attach the 50-pin flat cables to their mating halves on the module. Attach the cables by aligning the triangle marks on the cable end and the board socket. Make certain that the connectors are the proper ones for this module. The cable for channels 0-7 attaches to the middle connector. The cable for channels 8-15 attaches to the lower connector.
- Step 6. Turn on power to the rack.
- Step 7. Verify the installation. For DCS 5000/AutoMax, read the section entitled "DCS 5000/AutoMax Installation Verification. For AutoMate, go on to the section entitled "AutoMate Installation Verification."

## DCS 5000/AutoMax Installation Verification

Verify the installation by connecting the programming terminal to the system and running the ReSource Programming software. Note that you will need the application program disk that came with the ReSource Programming Software. Use the appropriate size disk for your particular disk drive. Perform the following steps to verify the installation of the module:

- a. Edit the file SETUP613.BAS in the DCS subdirectory. Customize the DATA statements beginning at statement 20000 to correctly describe your configuration.

- b. Compile the BASIC tasks TEST613.CNF, SETUP613.BAS, and KYBD613.BAS.
- c. Load the three tasks listed in step “b” onto the CPU.
- d. Use the RUN ALL command to start all three tasks.
- e. Disconnect the cable from the programming port on the CPU and connect it to the port labeled “PORT A”.
- f. Select the menu option labeled “COMMUNICATIONS INTERFACE” from the main DCS 5000 ReSource software menu.
- g. Type C <CR> <CR>.
- h. The programming terminal should now display the test and setup menu for the module. The menu reads “CHECKOUT MENU FOR 16 CHANNEL ANALOG INPUT MODULE”. Follow the instructions displayed on the menu to read the inputs from the module.

## AutoMate Installation Verification

In the AutoMate, each channel must be first configured for thermocouple type (J, K, etc.), voltage, gain, and offset, before reading the analog inputs. You will also need the application program disk that accompanied the module. The programs you will use are in the AutoMate subdirectory. They are identified by the file extension, e.g., extension 30 means the program is for use with an AutoMate 30. The last letter of the filename (m or s) identifies whether the program is for multiple modules (m) or a single module (s). As of the date of publication, not all of the application programs are available. If the specific application program you need is not included on the application disk, it will be necessary for you to enter the program manually.

- a. Using the AutoMate Programming Executive, edit the defaults for the 20,040 through 20,137 range of registers in the AutoMate application program included on the applications disk that accompanied the module.
- b. Note that the default slot number for the module is 4. Be sure to make the appropriate changes in the program if your module is not in that slot (i.e., change the address values in the MOVVM and MOVMR blocks). Once you have done so, edit registers 20,024 for the last analog channel (0-15) to be read and then edit registers 20,040 through 20,137. The program can now run and read the analog values based on the values you entered.
- c. Use to Point Register mode and call up point 0.00. Set the bit to a one. This is the start/run contact in the program used to: 1) configure the card, and 2) read the 16 channels. Once you have configured the card for the first time after power up and wish to do so again, you can: 1) power down and then up again, and set 0.00 to one, or 2) zero out register 3010 in the program and reset 0.00 from zero to one.
- d. The values of the analog inputs are read from registers 3500 through 3517. You can see these values using the Point Monitor mode.

## 3.2 Module Replacement

Use the following procedure to replace a module:

- Step 1. Turn off power to the rack and all connections.
- Step 2. Remove the connectors from the module.
- Step 3. Loosen the screws that hold the module in the rack. Take the module out of the slot in the rack.
- Step 4. Place the module in the anti-static bag it came in, being careful not to touch the connectors on the back of the module. Place the module in the cardboard shipping container.
- Step 5. Take the new module out of the anti-static bag, being careful not to touch the connectors on the back of the module.
- Step 6. Set the address switches for the slot that the module will be placed in. Refer to table 3.1 or 3.2.
- Step 7. Insert the module into the desired slot in the rack. Use a screwdriver to secure the module into the slot.
- Step 8. Attach the 50 pin flat cables to their mating halves on the module. Attach the cables by aligning the triangle marks on the cable end and the board socket. Make certain that the connectors are the proper ones for this module.
- Step 9. Turn on power to the rack.
- Step 10. Repeat step 7 in section 3.1.



## 4.0 PROGRAMMING

This section describes how the data is organized in the module and provides examples of how the module is accessed by the application software. For more detailed information refer to the AutoMate 30/40 Software Instruction Manual (J-3150) or the DCS 5000 BASIC Language Instruction Manual (J-3630).

The input module can operate in one of two modes: on-command and continuous. When operating in the on-command mode, the module will execute commands from the application software as they are received. This mode is used to send configuration and control information to the module. It may also be used to request data from a particular channel. Data read in this mode will always be current.

When the module is operating in the continuous mode, the data in all of the analog input channels that have been configured, as well as the cold-junction compensation value, are converted continuously and stored in memory on the input module. Application software may then request the latest reading. Data read in this mode may be as old as the sum of the conversion times for all of the channels.

### 4.1 Register Organization

The input module contains a total of four 8-bit bytes that can be accessed by application software. These locations begin at a base address (M) that is selected by rocker switch S1 (refer to table 3.1 or 3.2). The locations are sequential and are identified as (M+0), (M+1), (M+2), and (M+3). See table 4.1 for a description of all four locations.

Every command to the input module involves writing to (M+0), (M+1), and (M+2) in succession. Conversely, each response from the input module involves reading from (M+0), (M+1), and (M+2) in succession.

#### WARNING

**YOU SHOULD ORGANIZE YOUR APPLICATION SOFTWARE SO THAT ONLY ONE TASK COMMUNICATES WITH THIS MODULE. IF YOU DO NOT DO SO, THE DATA EXCHANGED IN THESE FOUR REGISTERS MAY NOT ALWAYS BE CORRECT AND UNINTENDED OPERATION OF THE CARD MAY RESULT. FAILURE TO OBSERVE THIS PRECAUTION COULD RESULT IN BODILY INJURY.**

Location (M+3) is a read-only location that is used by the application software to signal when the module has completed a command. Whenever data is written to location (M+2) by application software, (M+3) location will be set to zero. When the input module has completed the command and written the response back to location (M+2), (M+3) will be set to one.

On completion of every command, the module returns a status/error code in location (M+0). A value of zero indicates no errors, while a non-zero value indicates an error. You must check this status byte after the completion of every command since this is the only way in which you can detect a RESET that may have occurred on the module. Refer to Appendix E for a list of possible error codes. Note that, after power-up or board reset, the module returns a code "13".

Table 4.1 - Memory Locations

Location (M+0)	status/error from module; command from software
Location (M+1)	command from software
Location (M+2)	return value from module or software
Location (M+3)	not ready/ready from module

## 4.2 Command Descriptions

The module supports ten commands from your application software. These commands, which are described below, allow you to initialize, configure, and read data from the module. Sections 4.3.1 and 4.3.2 contain sample programs with examples of the commands described below.

### 4.2.1 Module Reset

The module reset command should always be executed as the first step in any initialization sequence. This command will cause the module to perform a power-up sequence. The module requires approximately 2 1/2 seconds to execute this command. The command contains the following information:

Location (M+0)	49
Location (M+1)	0
Location (M+2)	0

Note: location (M+0) will contain code "13" after module reset.

## 4.2.2 Module Initialization

Whenever power is turned on to the rack or the module is reset, it is necessary to initialize the module. Module initialization must follow module reset or power-up. The initialization command contains the following information:

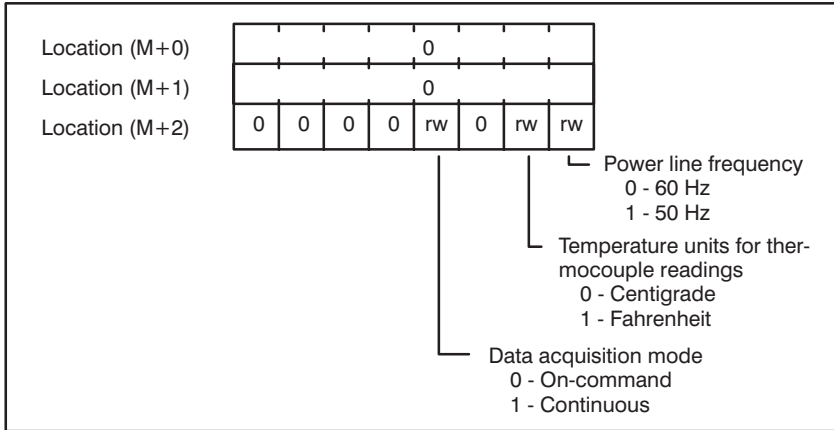

The power line frequency should be selected for maximum rejection of power line-induced noise.

The data acquisition mode specifies how the analog input channels will be read, either on-demand (refer to section 4.2.10) or continuously (refer to sections 4.2.7, 4.2.8, and 4.2.9).

## 4.2.3 Write Channel Number

The write channel number command sets a value into the module's channel register pointer, which defines the A/D channel for channel-specific commands. The write channel number command contains the following information:

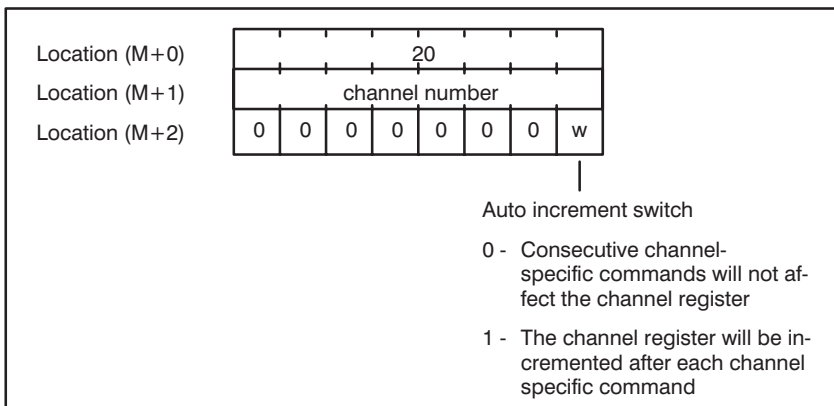

Valid channel numbers range from 0 to 15, corresponding to channels 0-15.

## 4.2.4 Configure Channel Input

In configuring the channel input, you define the type of signal that will be converted on a particular channel. If an input channel is not defined, the channel is considered to be unassigned and no A/D conversion will be performed. Refer to table 4.2 for a complete list of signals that the module will accept.

Table 4.2- Channel Signal Configuration

Channel Configuration Code	Analog Input	Conversion Precision	Conversion Time (max)
1	$\pm 10.000$ V	14 bit	75 msec
2	$\pm 5.000$ V	14 bit	75 msec
3	$\pm 2.500$ V	14 bit	75 msec
4 <sup>1</sup>	$\pm 1.250$ V	14 bit	75 msec
5 <sup>2</sup>	$\pm 100.0$ mV	14 bit	75 msec
6	$\pm 50.0$ mV	14 bit	75 msec
7	$\pm 25.0$ mV	14 bit	75 msec
8	$\pm 12.5$ mV	14 bit	75 msec
11	$\pm 10.000$ V	12 bit	45 msec
12	$\pm 5.000$ V	12 bit	45 msec
13	$\pm 2.500$ V	12 bit	45 msec
14 <sup>1</sup>	$\pm 1.250$ V	12 bit	45 msec
15 <sup>2</sup>	$\pm 100.0$ mV	12 bit	45 msec
16	$\pm 50.0$ mV	12 bit	45 msec
17	$\pm 25.0$ mV	12 bit	45 msec
18	$\pm 12.5$ mV	12 bit	45 msec
21	TC Type B	14 bit	110 msec
22	TC Type E	14 bit	110 msec
23	TC Type J	14 bit	110 msec
24	TC Type K	14 bit	110 msec
25	TC Type R	14 bit	110 msec
26	TC Type T	14 bit	110 msec

<sup>1</sup> Used with RTD inputs

<sup>2</sup> Used with RTD inputs with 0-200 Degree F range.

Before you attempt to define the signal type, you must first set the module's channel register pointer to the desired value. Refer to section 4.2.3 for more information. The configure channel input command contains the following information:

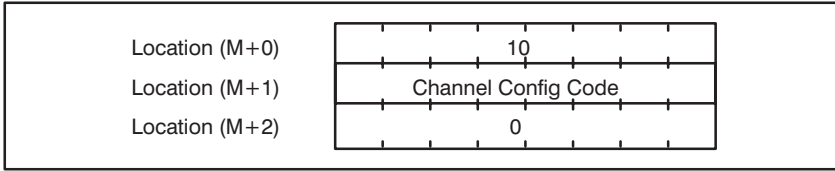

#### 4.2.5 Configure Channel Slope

The configure channel slope command is used to define a slope value for an analog input channel. If the slope is not defined for a channel, the default is 1. The module will multiply the converted analog value by the slope.

This feature is typically used to read small analog input voltages so as to maintain useful digital resolution. For example, if you have specified an input signal range of  $\pm 25.0$  mV, the digital values will range  $\pm 25$  counts. If you define a slope of 1000, then the digital values will range  $\pm 25000$  counts. Since the input circuitry can resolve up to 14 bits, this results in useful information.

This feature can also be used to change the voltages from the 61C615 RTD Termination Panel into temperatures. Use 200 as the slope in location (M+2) to read the input in degrees C and 36 as the slope to read the input in degrees F.

Before you attempt to configure the slope, you must first set the module's channel register pointer to the desired value (refer to section 4.2.3). The command to configure channel slope contains the following information:

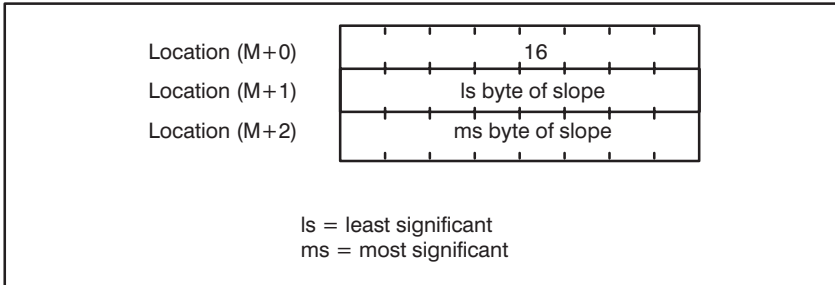

#### 4.2.6 Configure Channel Offset

The configure channel offset command is used to define an offset value for an analog input channel. If the offset is not defined for a channel, the default is 0. The module will add the offset to the converted value after the value has been multiplied by the slope.

You can use non-zero values of offset to generate user units from inputs corresponding to 4-20 mA signals, or from other signals with known and fixed offsets. This feature must also be used to read RTD

inputs as temperature inputs for degrees F. A value of 320 must be used as the offset.

Before you attempt to configure the offset, you must first set the module's channel register pointer to the desired value (refer to section 4.2.3). The command to configure channel offset contains the following information:

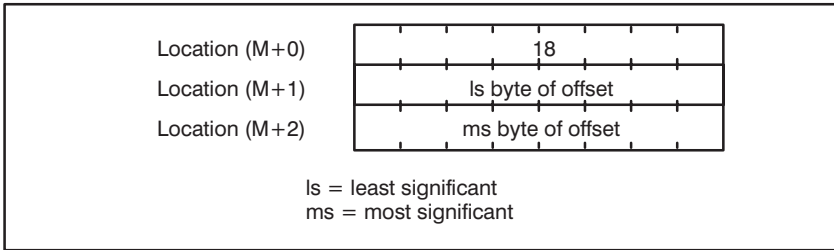

#### 4.2.7 Configure Scan Range for Continuous Mode

Configuring the scan range for the continuous mode involves defining the starting and ending channel numbers that are to be converted in the continuous scan mode. Channels that have not been defined will be skipped. The command contains the following information:

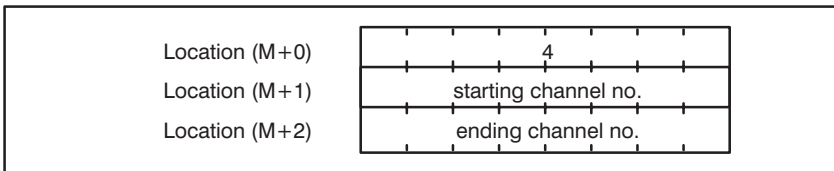

Valid channel numbers range from 0 to 15, corresponding to channels 0-15.

#### 4.2.8 Read Analog Input in Continuous Scan Mode

The command defined below is used to read an analog input value that had been converted in the continuous-scan mode, which must already have been selected (refer to sections 4.2.2 and 4.2.7). The command to read an analog input in continuous scan mode contains the following information:

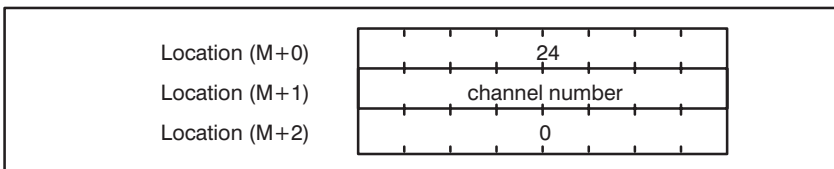

Valid channel numbers range from 0 to 15, corresponding to channels 0-15.

The data returned is a signed integer. Location (M+1) is the least significant byte, and location (M+2) is the most significant byte. Depending upon how the channel was configured and the temperature read-out units selected (refer to section 4.2.2), the units are either millivolts, degrees C, or degrees F.

#### 4.2.9 Read Analog Input on Demand

The command to convert and read an analog input value on demand will require between 45-110 milli-seconds to execute, depending on how the channel was configured. The command contains the following information:

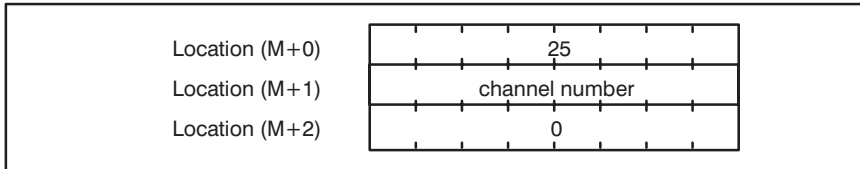

Valid channel numbers range from 0 to 15, corresponding to channel numbers 0-15.

The data returned is a signed integer. Location (M+1) is the least significant byte. Location (M+2) is the most significant byte. The units are either millivolts, degrees C, or degrees F, depending on how the channel was configured and the temperature read-out units selected. The units will also include any slope and offset specified for the channel.

### 4.3 Programming Examples

This section describes some simple programming examples for the 61C613, using write commands and read commands.

#### 4.3.1 Writing Commands with the DCS 5000/AutoMax

The following example is a DCS/AutoMax BASIC subroutine that will write a command to the module. This subroutine is written under the assumption that the command can be executed in a maximum of 33 milli-seconds.

```

15981 REM
15982 REM Write Commands to A/D
15983 REM
15984 REM Inputs:
15985 REM MI = hex address of module (02X0000H), X = slot
15986 REM OPCODE% = byte value written to (M+0)
15987 REM LS_BYTE% = byte value written to (M+1)
15988 REM MS_BYTE% = byte value written to (M+2)
15989 REM
15990 REM Output:
15991 REM ERR_CODE% = 0 if normal; non-zero if error
15992 REM
15999 REM
16000 IOWRITE( 1, OPCODE%, MI+0)
16010 IOWRITE( 1, LS_BYTE%, MI+1)
16020 IOWRITE( 1, MS_BYTE%, MI+2)
16100 FOR I% = 1 TO 3
16110 DELAY 2 TICKS
16120 STATUS% = IOREAD%( 1, MI+3)

```

```

16130     IF BIT_SET@(STATUS%,0) THEN GOTO 16200
16140     NEXT I%
16150     ERR_CODE% = -1           \! Retry Error
16160     RETURN
16197     REM
16198     REM   Read error code
16199     REM
16200     ERR_CODE% = IOREAD%( 1, M!)
16220     RETURN

```

### 4.3.2 Reading Data with the DCS 5000/AutoMax

The following example is a DCS/AutoMax BASIC subroutine that will read data converted in the continuous mode from the module. This subroutine uses the subroutine in section 4.3.1 to send the read command to the module.

```

14989     REM
14990     REM   Read channel data from 61C613 module
14991     REM
14992     REM Inputs:
14993     REM   M!           = hex address
14994     REM   OPCODE%     = instruction
14995     REM   CHANNEL     _NO% = channel number
14996     REM
14997     REM   Output:
14998     REM   VALUE%      = value received from the channel
14999     REM
15000     OPCODE%=24 \ LS_BYTE% =CHANNEL_NO% \ MS_BYTE%=0 \ GOSUB
15001     16000
15010     IF ERR_CODE% <> 0 THEN STOP
15047     REM
15048     REM   Read channel value
15049     REM
15050     LS_BYTE% = IOREAD%( 1, M!+1) \ MS_BYTE% = IOREAD%( 1, M!+2)
15060     VALUE% = SHIFTL%( MS_BYTE%, 8) +(LS_BYTE% AND 00FFH)
15070     RETURN

```



### 4.3.3 Writing Commands with the AutoMate

The following example is an AutoMate program that will write a RESET command to the module and read the ready bit. This program can be used to send any command from the AutoMate to the module. See Appendices G, H, and I for more information.

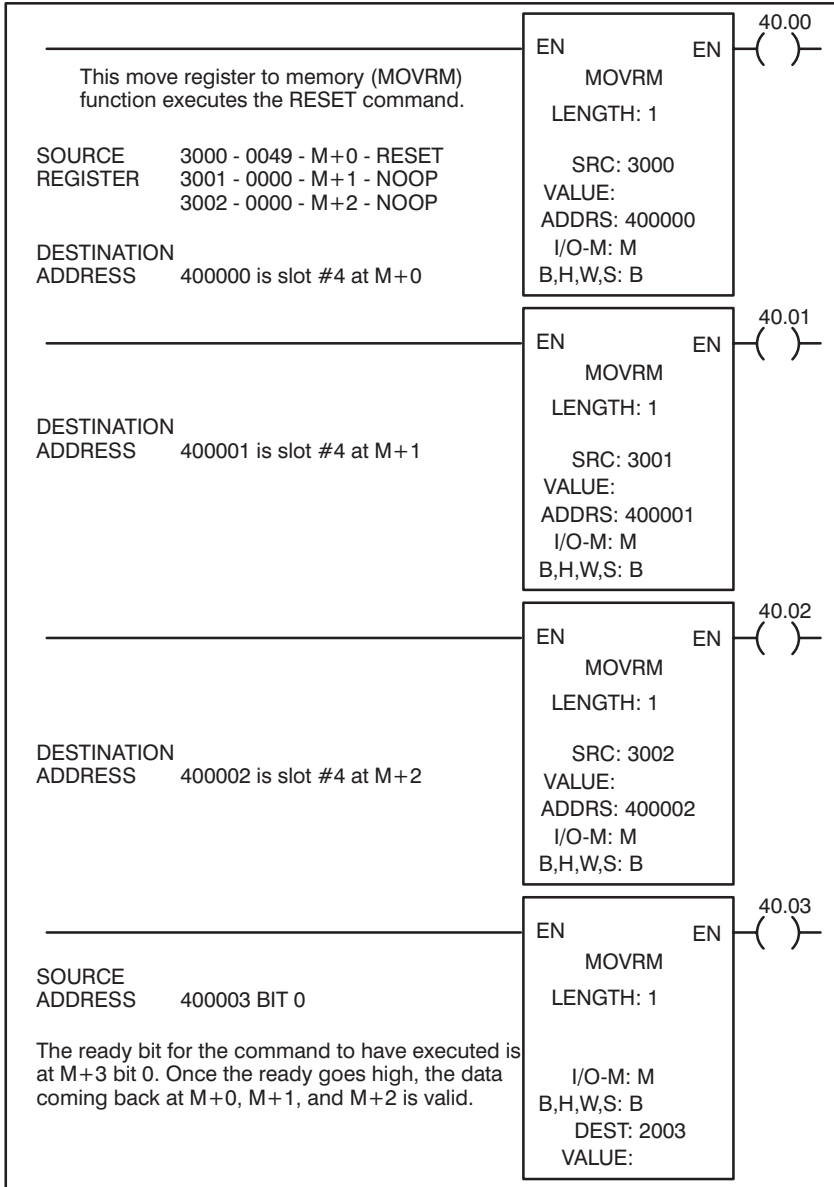

### 4.3.4 Reading Data with the AutoMate

The following example is an AutoMate program that will read data converted in the continuous mode from the module.

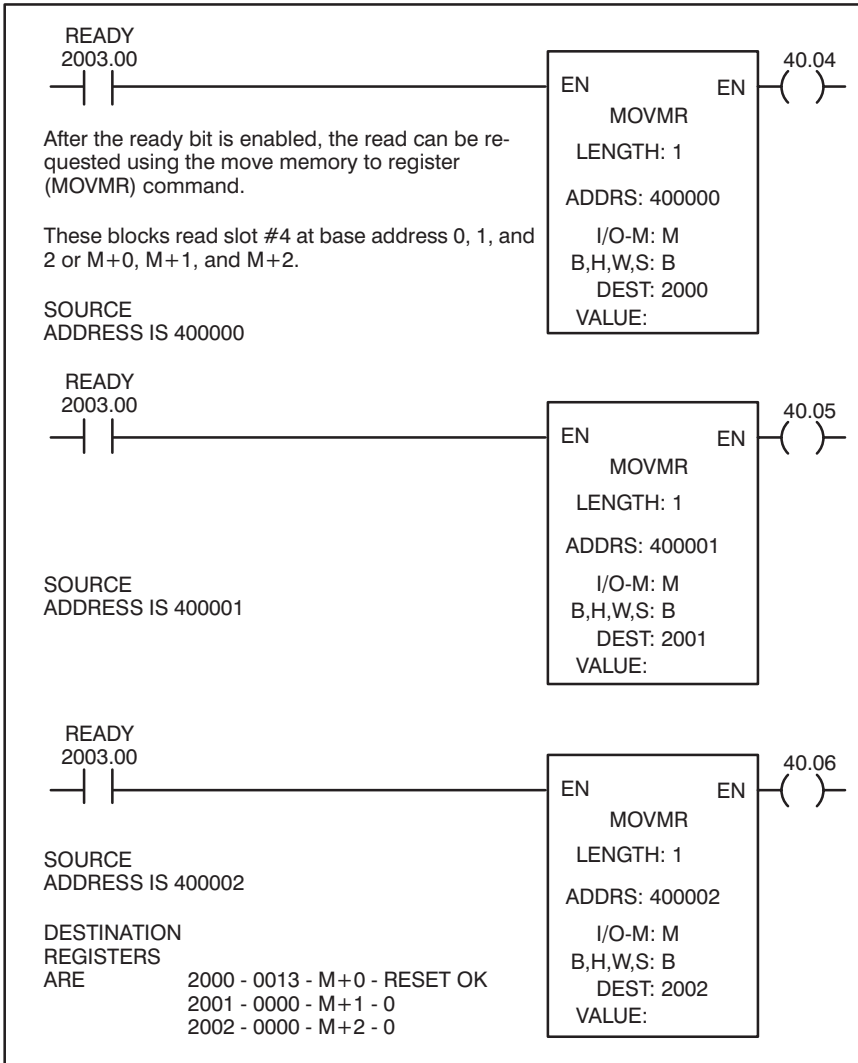

The MOVMR function block is used for both the setup data feedback and reading the analog inputs.

## **4.4 Restrictions**

This section describes limitations and restrictions on the use of this module.

### **4.4.1 Rack Slot Location**

This module cannot be used in a Remote I/O rack. A processor must be present in the same rack as the module. The module may not be used in slots 0 or 1 in a DCS 5000 rack.

If a micro-regulator is used in a DCS 5000/AutoMax rack, this module may not occupy any slot within a group of slots reserved for the micro-regulator. The two groups of slots reserved for the microregulator are slots 5-8 and 11-14.

### **4.4.2 Reading and Writing Data**

Data on the module can only be read or written as bytes. Location (M+3) is read only and may not be written to by application software.



# 5.0 DIAGNOSTICS AND TROUBLESHOOTING

This section explains how to troubleshoot the module and field connections.

## 5.1 Incorrect Data

**Problem:** The data is either always off, always on, or different than expected. When this happens the module is in the wrong slot or malfunctioning, or there is a programming error. It is also possible that the input is either not wired or wired to the wrong device. Use the following procedure to isolate the problem:

- Step 1    Verify that the input module is in the correct slot.  
          See section 4.4.1
- Step 2    Verify that rocker switches have been set correctly.  
          Refer to table 3.1 for the AutoMate 30/40 or table 3.2 for DCS 5000/AutoMax for the correct settings of the address switches.
- Step 3    Verify that the application software is written correctly.  
          Verify that your application program is referencing the proper module. Refer to the address that corresponds to the switch settings in table 3.1 or 3.2. Confirm that each channel has been configured correctly.
- Step 4    Verify that the module can be accessed.  
          Repeat step 7 in section 3.1. If the module now works you have a programming problem. Review the examples that have been provided. If the module does not work, there is a hardware problem. Proceed to step 5.
- Step 5    Verify that the input is wired to the correct device.  
          Confirm that all connections at the terminal strip are tight. Refer to Appendix C for a definition of terminal strip connections. Make certain that each input channel is wired to the correct field device.  
          Make certain that the 50-pin flat cables are secure and connected to the proper connectors on the module.  
          Connect a voltmeter to the proper points on the terminal strip and confirm that the external device is generating the correct voltage or current.  
          If you are using a 61C615 termination panel, measure the external power supply to verify that it is producing  $\pm 15$  volts.
- Step 6    Verify that the hardware is working correctly.  
          One at a time, swap out the input module, the termination panel, the processor (s), and finally the backplane. After each swap, if the problem has not been corrected, replace the original item before swapping out the next item.

## 5.2 Bus Error

Problem: Error code “31” or “16” appears on the DCS 5000/AutoMax processor module’s LEDs, or register 3764 in the A30 or 15764 in the A40 indicates a high bit in the corresponding slot. These errors indicate there was a problem when the system attempted to access the module. The possible causes of this error are a missing module, a module in the wrong slot, or a malfunctioning module. It is also possible that the user is attempting to write to the wrong registers on the module. Use the following procedure to isolate a bus error:

- Step 1     Verify that the input module is in the correct slot.  
            Refer to section 4.4.1
- Step 2     Verify that the rocker switches have been set correctly.  
            Refer to table 3.1 for the AutoMate 30/40 or 3.2 for DCS 5000/AutoMax for the correct settings of the address switches.
- Step 3     Verify that the application software has been written correctly.  
            Verify that your application program is referencing the proper module. Refer to the address that corresponds to the switch settings in table 3.1 or 3.2.
- Step 4     Verify that the module can be accessed.  
            Repeat step 7 in section 3.1. If the module now works you have a programming problem. Review the examples that have been provided. If the module does not work, there is a hardware problem. Proceed to step 5.
- Step 5     Verify that the hardware is working correctly.  
            One at a time, swap out the input module, the processor module (s), and the backplane. After each swap, if the problem has not been corrected, replace the original item before swapping out the next item.

# Appendix A

## Technical Specifications

### Ambient Conditions

- Storage temperature: -25C - 85C
- Operating temperature: 0C - 60C
- Humidity: 5-95% non-condensing

### Maximum Module Power Dissipation

- 6 Watts

### Dimensions

- Height: 11.75 inches
- Width: 1.25 inches
- Depth: 7.375 inches

### System Power Requirements

- +5 volts: 1250 mA

### A/D Specifications

- Number of input channels: 16
- Type of input: Differential
- Maximum input voltage: 40V RMS continuous
- Input Impedance: 10M ohm minimum
- Common mode input impedance: 10,000M ohm in parallel with 80pf, typ.
- Common mode voltage (max.): 1000VDC (channel-ground)  
200VDC (channel-channel)
- Common mode rejection ratio: 100db @ 60Hz, min
- Voltage ranges:  $\pm 12.5\text{mV}$ ,  $\pm 25.00\text{mV}$ ,  
 $\pm 50.00\text{mV}$ ,  $\pm 100.00\text{mV}$   
 $\pm 1.25\text{V}$ ,  $\pm 2.50\text{V}$ ,  
 $\pm 5.00\text{V}$ ,  $\pm 10.00\text{V}$
- Thermocouple inputs: E, J, K, T, B, R
- Resolution: 12 or 14 bits, software selectable
- Conversion time: 45 msec max for 12 bits per channel  
75 msec max for 14 bits per channel  
75 msec for the thermocouple per channel

# Appendix A

## (Continued)

- Offset temperature coefficient
  - $\pm\mu\text{Volts/Deg. C (max)}$ : 0.0025 -  $\pm 12.50\text{mV range}$
  - 0.005 -  $\pm 25.00\text{mV range}$
  - 0.01 -  $\pm 50.00\text{mV range}$
  - 0.02 -  $\pm 100.00\text{mV range}$
  - 0.25 -  $\pm 1.25\text{V range}$
  - 0.5 -  $\pm 2.50\text{V range}$
  - 1.0 -  $\pm 5.00\text{V range}$
  - 2.0 -  $\pm 10.0\text{V range}$
- Gain temperature coefficient:  $\pm 5\text{ppm/deg.C (max)}$
- Non-linearity:  $\pm 0.0125\% \text{FSR (max)}$
- Filter characteristics (typ.): 1-pole, 20dB/decade, -3dB @ 5hz, -23dB @ 50hz
- Warm-up time (max): 15 min. to  $\pm 0.003\% \text{FSR}$
- Long term drift:  $\pm 5\text{ppm/month max}$
- Voltage noise:  $\pm .5 \mu\text{Volts RMS}$   
(.01Hz-5Hz) RTI max
- Cross channel interference:  $\pm 3 \mu\text{Volts RTI max}$
- Reference junction error:  $\pm 0.4 \text{deg.C max}$
- Linearization conformance:  $\pm 0.2 \text{deg.C max}$



# Appendix A

## (Continued)

### Linear Performance (14 bits)

The following table details guaranteed accuracy and repeatability as compared to National Bureau of Standards measurements using primary voltage standards. All sources of error have been included. The following conditions apply:

1. Measurement is within 30 days of calibration.
2. Ambient temperature is 0-60 degrees C, draft-free and steady.
3. Common mode voltage = 0.

Range	Resolution	Absolute Accuracy
$\pm 12.50$ mvolts	0.76 $\mu$ volts	$\pm 6$ $\mu$ volts
$\pm 25.00$ mvolts	1.53 $\mu$ volts	$\pm 8$ $\mu$ volts
$\pm 50.00$ mvolts	3.05 $\mu$ volts	$\pm 12$ $\mu$ volts
$\pm 100.00$ mvolts	6.10 $\mu$ volts	$\pm 24$ $\mu$ volts
$\pm 1.25$ volts	76.25 $\mu$ volts	$\pm 300$ $\mu$ volts
$\pm 2.50$ volts	152.5 $\mu$ volts	$\pm 600$ $\mu$ volts
$\pm 5.00$ volts	305. $\mu$ volts	$\pm 1200$ $\mu$ volts
$\pm 10.00$ volts	610. $\mu$ volts	$\pm 2400$ $\mu$ volts

# Appendix A

## (Continued)

### Thermocouple Performance (14 bits)

ANSI Thermocouple Curve Conformance:  $\pm 0.2$  deg F max

The following table details guaranteed accuracy and repeatability as compared to National Bureau of Standards measurements using primary standards and ANSI thermocouple curves. All sources of error have been included. The following conditions apply:

1. Measurement is within 30 days of calibration.
2. Ambient temperature is 0-60 degrees C, draft-free and steady.
3. Common mode voltage = 0.

ANSI Thermocouple Type	Range (degrees F)	Accuracy (degrees F)	Range (degrees C)	Accuracy (degrees C)
E	-382 to 32	$\pm 2.9$	-230 to 0	$\pm 1.6$
	32 to 1832	$\pm 1.4$	0 to 1000	$\pm 0.8$
J	-346 to 32	$\pm 1.7$	-210 to 0	$\pm 0.9$
	32 to 1400	$\pm 1.3$	0 to 760	$\pm 0.7$
K	-328 to 32	$\pm 3.2$	-200 to 0	$\pm 1.8$
	32 to 2500	$\pm 2.0$	0 to 1200	$\pm 1.1$
T	-436 to 32	$\pm 3.7$	-260 to 0	$\pm 2.1$
	32 to 752	$\pm 1.3$	0 to 400	$\pm 0.7$
B	32 to 752	$\pm 20$	0 to 400	$\pm 12$
	752 to 3308	$\pm 2.8$	400 to 1820	$\pm 1.6$
R	32 to 3213	$\pm 2.8$	0 to 1768	$\pm 1.6$

# Appendix B

## Module Block Diagram

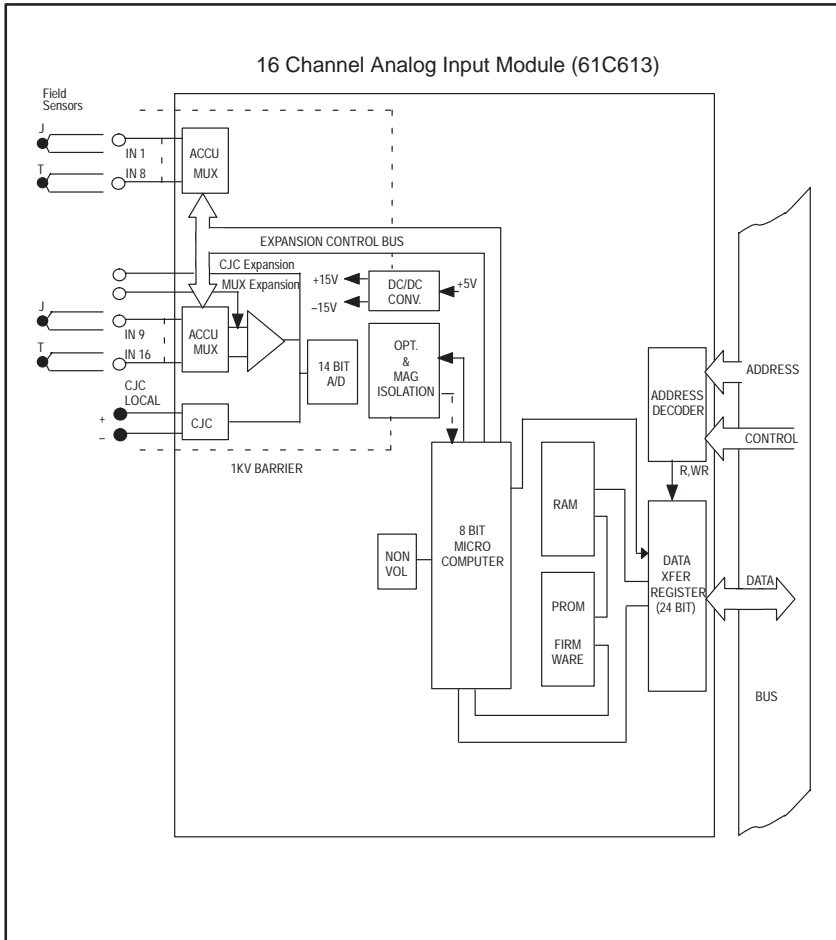



# Appendix C

## Module Connections – Channels 8-15

Pin	Signal	Pin	Signal
1	n.c.	2	Channel 8 (+)
3	Channel 8 (-)	4	n.c.
5	n.c.	6	n.c.
7	n.c.	8	Channel 9 (+)
9	Channel 9 (-)	10	n.c.
11	n.c.	12	n.c.
13	n.c.	14	Channel 10 (+)
15	Channel 10 (-)	16	n.c.
17	n.c.	18	n.c.
19	n.c.	20	Channel 11 (+)
21	Channel 11 (-)	22	n.c.
23	n.c.	24	n.c.
25	n.c.	26	Channel 12 (+)
27	Channel 12 (-)	28	n.c.
29	n.c.	30	n.c.
31	n.c.	32	Channel 13 (+)
33	Channel 13 (-)	34	n.c.
35	n.c.	36	n.c.
37	n.c.	38	Channel 14 (+)
39	Channel 14 (-)	40	n.c.
41	n.c.	42	n.c.
43	n.c.	44	Channel 15 (+)
45	Channel 15 (-)	46	n.c.
47	n.c.	48	n.c.
49	n.c.	50	n.c.

# Appendix C

(Continued)

## Module Connections – Channels 0-7

Pin	Signal	Pin	Signal
1	n.c.	2	Channel 0 (+)
3	Channel 0 (-)	4	n.c.
5	n.c.	6	n.c.
7	n.c.	8	Channel 1 (+)
9	Channel 1 (-)	10	n.c.
11	n.c.	12	n.c.
13	n.c.	14	Channel 2 (+)
15	Channel 2 (-)	16	n.c.
17	n.c.	18	n.c.
19	n.c.	20	Channel 3 (+)
21	Channel 3 (-)	22	n.c.
23	n.c.	24	n.c.
25	n.c.	26	Channel 4 (+)
27	Channel 4 (-)	28	n.c.
29	n.c.	30	n.c.
31	n.c.	32	Channel 5 (+)
33	Channel 5 (-)	34	n.c.
35	n.c.	36	n.c.
37	n.c.	38	Channel 6 (+)
39	Channel 6 (-)	40	n.c.
41	n.c.	42	n.c.
43	n.c.	44	Channel 7 (+)
45	Channel 7 (-)	46	n.c.
47	n.c.	48	n.c.
49	Temp Sensor (+)	50	Temp Sensor (-)

# Appendix D

## Related Components

### **M/N 61C614 Thermocouple/Voltage Termination Panel**

This assembly consists of a rack-mountable termination panel that can be used to terminate analog field signals from thermocouples, voltage, or current sources. It also includes two 6-ft. 50 pin flat cables to connect the termination panel to the 61C613 16 Channel Analog Input Module.

### **M/N 61C615 RTD Termination Panel**

This assembly consists of a rack mountable termination panel that can be used to terminate field signals from 100 ohm platinum RTDs. It also includes two 6-ft. 50 pin twisted pair cables to connect the termination panel to the 61C613 16 Channel Analog Input Module and a 6-ft. power supply cable. A  $\pm 15$  volt power supply is required (to be supplied by the user).

### **420300-315**

A 5 1/4" floppy disk containing both AutoMate and DCS 5000/AutoMax application programs for the 61C613 input module. It contains the same programs as the 420300-316.

### **420300-316**

A 3 1/2" disk containing both AutoMate and DCS 5000/AutoMax application programs for the 61C613 input module. It contains the same programs as the 420300-315.





# Appendix E

## Command Summary

(M+0)	(M+1)	(M+2)	Command
49	0	0	module reset
0	0	*1	module initialization
20	ch. #	*2	write channel number
10	ch. config. code	0	configure channel input
16	ls byte slope	ms byte slope	configure channel slope
18	ls byte offset	ms byte offset	configure channel offset
4	start ch. #	end ch. #	configure scan range for continuous mode
24	ch. #	0	read analog input in continuous scan mode
25	ch. #	0	read analog input on demand

\*1 = set individual bits

bit 0: power line frequency

0 = 60Hz

1 = 50 Hz

bit 1: temperature units for thermocouple readings

0 = Centigrade

1 = Fahrenheit

bit 3: data acquisition mode

0 = on-command

1 = continuous

\*2 = set individual bits

bit 0: auto increment

0 = consecutive channel; specific commands will not affect the channel register

1 = channel register will be incremented after each channel-specific command



# Appendix F

## Error Codes

<b>Error Code</b>	<b>Description</b>
4	Module busy; can't accept command
5	Scan in progress; can't accept command
7	Illegal scan range or channel number
8	Illegal kind code
9	Numeric overflow (output > +/- 32767)
10	Numeric underflow (output < 1/65536)
11	EArom checksum error on powerup
13	Board reset
14	Invalid command
15	Command incompatible with current setup
20	Attempted conversion on an un-assigned channel (i.e. a channel whose kind code is zero)



# Appendix G

## AutoMate Program Setup Table

20,040	0000		SLOT # 4 CHANNEL # 0
20,041	0023	J T/C	TYPE CODE NUMBER - CHANNEL # 0
20,042	0001		M-SLOPE VALUE - CHANNEL # 0
20,043	0000		B-OFFSET VALUE - CHANNEL # 0
20,044	0001		SLOT # 4 CHANNEL # 1
20,045	0023		TYPE CODE NUMBER - CHANNEL # 1
20,046	0001		M-SLOPE VALUE - CHANNEL # 1
20,047	0000		B-OFFSET VALUE - CHANNEL # 1
20,050	0002		SLOT # 4 CHANNEL # 2
20,051	0023		TYPE CODE NUMBER - CHANNEL # 2
20,052	0001		M-SLOPE VALUE - CHANNEL # 2
20,053	0000		B-OFFSET VALUE - CHANNEL # 2
20,054	0003		SLOT # 4 CHANNEL # 3
20,055	0024	K T/C	TYPE CODE NUMBER - CHANNEL # 3
20,056	0001		M-SLOPE VALUE - CHANNEL # 3
20,057	0000		B-OFFSET VALUE - CHANNEL # 3
20,060	0004		SLOT # 4 CHANNEL # 4
20,061	0024		TYPE CODE NUMBER - CHANNEL # 4
20,062	0001		M-SLOPE VALUE - CHANNEL # 4
20,063	0000		B-OFFSET VALUE - CHANNEL # 4
20,064	0005		SLOT # 4 CHANNEL # 5
20,065	0024		TYPE CODE NUMBER - CHANNEL # 5
20,066	0001		M-SLOPE VALUE - CHANNEL # 5
20,067	0000		B-OFFSET VALUE - CHANNEL # 5
20,070	0006		SLOT # 4 CHANNEL # 6
20,071	0025	R T/C	TYPE CODE NUMBER - CHANNEL # 6
20,072	0001		M-SLOPE VALUE - CHANNEL # 6
20,073	0000		B-OFFSET VALUE - CHANNEL # 6
20,074	0007		SLOT # 4 CHANNEL # 7
20,075	0001	10.0V-14b	TYPE CODE NUMBER - CHANNEL # 7
20,076	0001		M-SLOPE VALUE - CHANNEL # 7
20,077	0000		B-OFFSET VALUE - CHANNEL # 7
20,100	0008		SLOT # 4 CHANNEL # 8
20,101	0001		TYPE CODE NUMBER - CHANNEL # 8
20,102	0001		M-SLOPE VALUE - CHANNEL # 8
20,103	0000		B-OFFSET VALUE - CHANNEL # 8
20,104	0009		SLOT # 4 CHANNEL # 9
20,105	0011	10.0V-12b	TYPE CODE NUMBER - CHANNEL # 9
20,106	0001		M-SLOPE VALUE - CHANNEL # 9
20,107	0000		B-OFFSET VALUE - CHANNEL # 9
20,110	0010		SLOT # 4 CHANNEL # 10
20,111	0011		TYPE CODE NUMBER - CHANNEL # 10
20,112	0001		M-SLOPE VALUE - CHANNEL # 10
20,113	0000		B-OFFSET VALUE - CHANNEL # 10

# Appendix G

## (Continued)

20,114	0011		SLOT # 4 CHANNEL # 11
20,115	0012	5.0V-12b	TYPE CODE NUMBER - CHANNEL # 11
20,116	0001		M-SLOPE VALUE - CHANNEL # 11
20,117	0000		B-OFFSET VALUE - CHANNEL # 11
20,120	0012		SLOT # 4 CHANNEL # 12
20,121	0012		TYPE CODE NUMBER - CHANNEL # 12
20,122	0001		M-SLOPE VALUE - CHANNEL # 12
20,123	0000		B-OFFSET VALUE - CHANNEL # 12
20,124	0013		SLOT # 4 CHANNEL # 13
20,125	0012		TYPE CODE NUMBER - CHANNEL # 13
20,126	0001		M-SLOPE VALUE - CHANNEL # 13
20,127	0000		B-OFFSET VALUE - CHANNEL # 13
20,130	0014		SLOT # 4 CHANNEL # 14
20,131	0004	RTD-1.25	TYPE CODE NUMBER - CHANNEL # 14
20,132	36*		M-SLOPE VALUE - CHANNEL # 14
20,133	320		B-OFFSET VALUE - CHANNEL # 14
20,134	0015		SLOT # 4 CHANNEL # 15
20,135	0004	RTD	TYPE CODE NUMBER - CHANNEL # 15
20,136	0000**		M-SLOPE VALUE - CHANNEL # 15
20,137	0000		B-OFFSET VALUE - CHANNEL # 15

\* This will give a temperature reading scaled in degrees F.

\*\* This will give a temperature reading scaled in degrees C.

# Appendix H

## AutoMate Program Command Register Table

REGISTER	DATA	ADDRESS	COMMENTS
20,000	0049	M + 0	RESET
20,001	0000	M + 1	NOOP
20,002	0000	M + 2	NOOP
20,003	0000	M + 0	INITIALIZE SETUP
20,004	0000	M + 1	SETUP
20,005	0000	M + 2	SETUP
20,006	0020	M + 0	WRITE CHANNEL REGISTER
20,007	WWWW	M + 1	CHANNEL NUMBER
20,010	0000	M + 2	DISABLE AUTO-INCREMENT ON CHANNEL NUMBER
20,011	0010	M + 0	CONFIGURE CHANNEL INPUT
20,012	XXXX	M + 1	TYPE OF ANALOG INPUT (SEE TABLE)
20,013	0000	M + 2	NOOP
20,014	0016	M + 0	CONFIGURE CHANNEL SLOPE
20,015	YYYY	M + 1	LOW ORDER BYTE
20,016	ZZZZ	M + 2	HIGH ORDER BYTE
20,017	0018	M + 0	CONFIGURE CHANNEL OFFSET
20,020	YYYY	M + 1	LOW ORDER BYTE
20,021	ZZZZ	M + 2	HIGH ORDER BYTE
20,022	0004	M + 0	CONFIGURE SCAN RANGE
20,023	0000	M + 1	START AT CHANNEL 0
20,024	0015	M + 2	STOP AT CHANNEL 15*
20,025	0000	M + 0	INITIALIZE SCAN
20,026	0000	M + 1	NOOP
20,027	0008**	M + 2	60 HZ,CENTIGRADE, 16 BIT MODE CONTINUOUS SCAN
20,030	0024	M + 0	READ ANALOG INPUT CHANNEL
20,031	0000	M + 1	CHANNEL NUMBER POINTER
20,032	0000	M + 2	NOOP

\* USER MUST DEFINE THE LAST CHANNEL USED; DEFAULT IS 15 IN THIS CASE.

\*\* 0008 = 1 0 0 0

- └─ POWER LINE FREQUENCY; 0 - 60Hz, 1 - 50Hz
- └─ TEMPERATURE UNITS
  - 0 = CENTIGRADE, 1 = FARENHEIT
  - Note: This is only used with the T/C kind codes.
- └─ DATA ACQUISITION MODE
  - 0 = ON-COMMAND, 1 = CONTINUOUS SCAN





# Appendix I

## AutoMate Program Analog Input Table

REGISTER	DATA	COMMENTS
3500	0-10000	ANALOG INPUT - SLOT # 4 CHANNEL 0
3501	0-10000	ANALOG INPUT - SLOT # 4 CHANNEL 1
3502	0-10000	ANALOG INPUT - SLOT # 4 CHANNEL 2
3503	0-10000	ANALOG INPUT - SLOT # 4 CHANNEL 3
3504	0-10000	ANALOG INPUT - SLOT # 4 CHANNEL 4
3505	0-10000	ANALOG INPUT - SLOT # 4 CHANNEL 5
3506	0-10000	ANALOG INPUT - SLOT # 4 CHANNEL 6
3507	0-10000	ANALOG INPUT - SLOT # 4 CHANNEL 7
3510	0-10000	ANALOG INPUT - SLOT # 4 CHANNEL 8
3511	0-10000	ANALOG INPUT - SLOT # 4 CHANNEL 9
3512	0-10000	ANALOG INPUT - SLOT # 4 CHANNEL 10
3513	0-10000	ANALOG INPUT - SLOT # 4 CHANNEL 11
3514	0-10000	ANALOG INPUT - SLOT # 4 CHANNEL 12
3515	0-10000	ANALOG INPUT - SLOT # 4 CHANNEL 13
3516	0-10000	ANALOG INPUT - SLOT # 4 CHANNEL 14
3517	0-10000	ANALOG INPUT - SLOT # 4 CHANNEL 15





## **For additional information**

1 Allen-Bradley Drive

Mayfield Heights, Ohio 44124 USA

Tel: (800) 241-2886 or (440) 646-3599

<http://www.reliance.com/automax>

[www.rockwellautomation.com](http://www.rockwellautomation.com)

### **Corporate Headquarters**

Rockwell Automation, 777 East Wisconsin Avenue, Suite 1400, Milwaukee, WI, 53202-5302 USA, Tel: (1) 414.212.5200, Fax: (1) 414.212.5201

### **Headquarters for Allen-Bradley Products, Rockwell Software Products and Global Manufacturing Solutions**

Americas: Rockwell Automation, 1201 South Second Street, Milwaukee, WI 53204-2496 USA, Tel: (1) 414.382.2000, Fax: (1) 414.382.4444  
Europe/Middle East/Africa: Rockwell Automation SA/NV, Vorstlaan/Boulevard du Souverain 36, 1170 Brussels, Belgium, Tel: (32) 2 663 0600, Fax: (32) 2 663 0640  
Asia Pacific: Rockwell Automation, 27/F Citicorp Centre, 18 Whitfield Road, Causeway Bay, Hong Kong, Tel: (852) 2887 4788, Fax: (852) 2508 1846

### **Headquarters for Dodge and Reliance Electric Products**

Americas: Rockwell Automation, 6040 Ponders Court, Greenville, SC 29615-4617 USA, Tel: (1) 864.297.4800, Fax: (1) 864.281.2433  
Europe/Middle East/Africa: Rockwell Automation, Brühlstraße 22, D-74834 Elztal-Dallau, Germany, Tel: (49) 6261 9410, Fax: (49) 6261 17741  
Asia Pacific: Rockwell Automation, 55 Newton Road, #11-01/02 Revenue House, Singapore 307987, Tel: (65) 6356-9077, Fax: (65) 6356-9011