

# Installation Instructions

## Bulletin 873C Ultrasonic Proximity Sensor

IMPORTANT: SAVE THESE INSTRUCTIONS FOR FUTURE USE.



**CAUTION:** Solid-state devices can be susceptible to radio frequency (RF) interference depending on the power and the frequency of the transmitting source. If RF transmitting equipment is to be used in the vicinity of the solid state devices, thorough testing should be performed to assure that transmitter operation is restricted to a safe operating distance from the control equipment and its wiring.



**WARNING:** If a hazardous condition can result from unintended operation of this device, access to the sensing area should be guarded.

### Specifications

	Switching Output	Analog Output
<b>New Part Number</b>	873C-DDNP1000E2	873C-DDAV1000E2
<b>Old Part Number</b>	873C-D30NP30-E2	873C-D30AP30-E2
<b>Nominal Sensing Distance</b>	30cm (11.8 in.) to 1m (39.4 in.)	
<b>Output Configuration</b>	N.O., PNP	Analog, PNP
<b>Operating Voltage</b>	18–30V DC	
<b>Load Current</b>	≤400mA	≤5mA
<b>Minimum Load Current</b>	1mA	
<b>Leakage Current</b>	≤10μA	
<b>Voltage Drop</b>	≤2.4V	
<b>Repeatability</b>	±5mm in axial direction	
<b>Hysteresis</b>	≤15mm typical	
<b>Ultrasonic Frequency</b>	200kHz	
<b>Max. Switching Frequency</b>	5Hz	
<b>Ultrasonic Pulse Cone Angle</b>	8° (full angle)	
<b>False Pulse Protection</b>	Incorporated	
<b>Transient Noise Protection</b>	Incorporated	
<b>Reverse Polarity Protection</b>	Incorporated	
<b>Short Circuit Protection</b>	Incorporated	
<b>Overload Protection</b>	Incorporated	
<b>Enclosure</b>	NEMA 12 and IP65 (IEC 529) Nickel-plated brass barrel	
<b>Connection</b>	Cable: 2-meter (6.5 ft.) length 3-conductor PVC	
<b>LED</b>	Output Energized	
<b>Operating Temperature</b>	-10°C to +60°C (-14°F to +140°F)	
<b>Shock and Vibration</b>	30G, 10–55Hz	

### Description

Bulletin 873C ultrasonic sensors are solid-state devices designed for noncontact sensing of solid and liquid objects.

The normally open switching (discrete) model features a long sensing range which can be adjusted between 30cm (11.8in) and 1m (3.3ft). All sound-reflecting objects that are within the selected sensing range and more than 30cm from the sensor face can be detected.

The analog model provides an output voltage that varies linearly with target distance. For many applications, such as monitoring the level of water in a tank or accurately positioning a cardboard box, this technology allows a single device to do a job that would otherwise require multiple sensors.

Each unit is housed by a plastic face and a nickel-plated brass barrel which meet NEMA 12 and IP65 (IEC 529) enclosure standards. It is equipped with a 2m (6.6ft) PVC cable and an LED which glows when a target is detected.

### Theory of Operation

Ultrasonic sensors emit bursts of high-frequency sound waves which reflect or “echo” from a target. When the device detects an echo, it energizes the load. This allows these sensors to detect an object of any shape and material that can sufficiently reflect an ultrasonic pulse.

Each switch senses the distance from its face to the target by measuring the length of time required for the echo to return. The analog model converts the time value to a DC output voltage. The discrete model compares this time to a pre-set value (set by the user at installation) and energizes the load when the time drops below the threshold.

### Sensing Distance

The 873C is designed to detect objects which are between 30cm (11.8in) and 1m (39.4in) from the sensor face. The discrete switching model's maximum sensing distance can be adjusted within this range by turning the potentiometer on the end of the sensor.

Any objects in front of the sensor must be at least 30cm from the detector face. Objects closer than 30cm will not be detected and will block the sound waves coming from the sensor.

### Analog Output Voltage vs. Target Distance (Background Suppression at Maximum Distance)

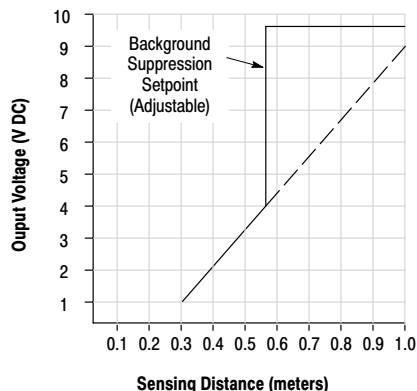

## Background Suppression and Non-Target Objects

The analog model offers a background suppression feature which allows the sensor to ignore all objects beyond a specified distance. This distance is set by the user at installation by turning the potentiometer on the end of the sensor.

Non-target objects in the sensing field can be “hidden” from the sensor by covering them with sound-absorbent material or by positioning them so that their echoes are reflected away from the sensor.

## Target Considerations

Because ultrasonic sensors depend on a reflected sound wave for proper operation, the shape, material, temperature and positioning of the target are important. These must be selected to return the strongest echo, otherwise the sensing distance will be reduced or the target will not be detected.

The ideal target shape is a smooth, flat surface. Rounded or uneven objects can also be detected, but the sensing distances and/or analog output voltages may be reduced.

An object must be close to the sensor barrel axis to be detected because the 873C emits ultrasonic pulses in an 8° cone. Targets must be within this cone to reflect the pulses and activate the switch. The object's surface must also face directly toward the sensor to give a proper echo.

Material thinner than 0.01mm (0.0004in) and soft materials such as fabric or foam rubber are difficult to detect by ultrasonic technology because they are not adequately sound-reflective.

Target temperatures must be at or below 100° C (212° F) for reliable sensing. Targets at higher temperatures create convection currents in the air near their surfaces, which disturbs the reflection of the ultrasonic pulse.

## Mounting Considerations

The control must be securely mounted on a firm, stable surface or support. A mounting configuration which is unstable or subject to excessive vibration may cause intermittent operation.

An 873C sensor can be mounted with its sensing face flush to surrounding surfaces. This does not effect sensing distance.

A mounting location should be chosen such that the target's surface faces directly toward the sensor.

When more than one 873C is in use, the following inter-sensor spacings must be maintained:

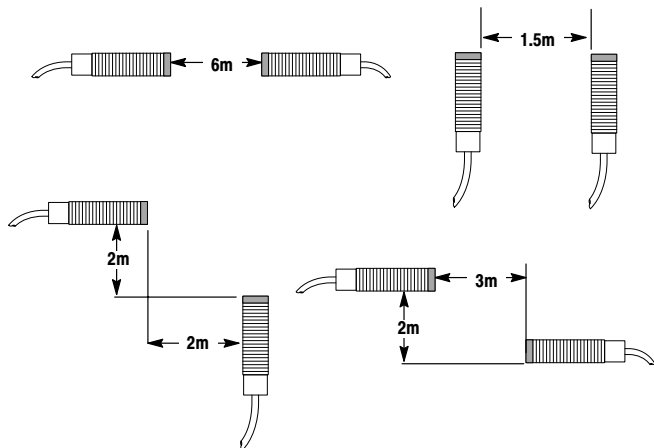

## Environmental Factors

The output of these devices drifts approximately 0.2% per degree Celsius of temperature change. The analog model output voltage drops slightly as the temperature increases, even if the target has not moved. The sensing distance of the discrete switching model rises with increased temperature.

Strong air turbulence and convection currents can interfere with operation of the sensor. Installation of baffles around the sound cone can help to reduce these effects.

Liquid splashes or heavy condensation on the face of the sensor can interfere with proper operation. In liquid applications, the device could be protected by relaying the ultrasonic pulse to the surface of the liquid via a flat “bounce panel.” Installing shielding around the sensor can also help to reduce splash and condensation interference.

873C ultrasonic sensors are **not** effected by humidity, dust, mist, or changes in atmospheric pressure.

## Wiring

All external wiring should conform to the National Electric Code and applicable local codes. Connect the proximity switch to the power supply and load as shown in the wiring diagrams and as described below.

1. Connect the BROWN wire from the proximity control to the positive (+) side of the 18–30V DC supply.
2. Connect the BLUE wire from the proximity control to the negative (–) side of the 18–30V DC supply.
3. Connect the BLACK wire from the proximity control to the positive input of the load.

NOTE: If the positive (+) and negative (–) wires are reversed, the switch will not operate properly. The sensor will not be damaged because it is equipped with reverse polarity protection.

NOTE: These switches are equipped with protection against transient noise. However, it is recommended that the proximity cable not be placed in the same conduit as AC power wiring.

### Normally Open Switching PNP (Sourcing)

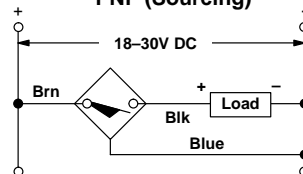

### Analog PNP (Sourcing)

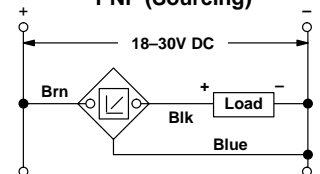

## Wiring Switches in Series and Parallel

Series and parallel connection of this product is not recommended.

## Alignment

The sensor can be positioned accurately using the LED on its end, which glows with an intensity proportional to the strength of the echo. Align the device as described below:

1. Place the target in the desired sensing position.
2. Choose a sensor location such that the surface of the target faces directly toward the sensor. The distance between the target and the switch must be between 30cm (11.8in) and 1m (39.4in).
3. Mount the sensor on a firm, stable surface or support.
4. Apply power to the sensor as described above.
5. Turn the potentiometer on the end of the sensor fully clockwise. This will disable the analog model background suppression or set the discrete switching model sensing distance to maximum. Check that the LED turns on.
6. Adjust the angle of the sensor to maximize the brightness of the LED.
7. (Analog model only) If the analog model is sensing objects behind the desired target, turn the potentiometer on the end of the sensor counter-clockwise to suppress the background objects, but not so far that the sensor no longer detects the target.
8. (Discrete switching model only) Adjust the potentiometer on the discrete switching model counter-clockwise until the LED turn off, then *slowly* clockwise until the LED turns back on. The sensing distance is now set at the target location.

## Dimensions—mm (inches)

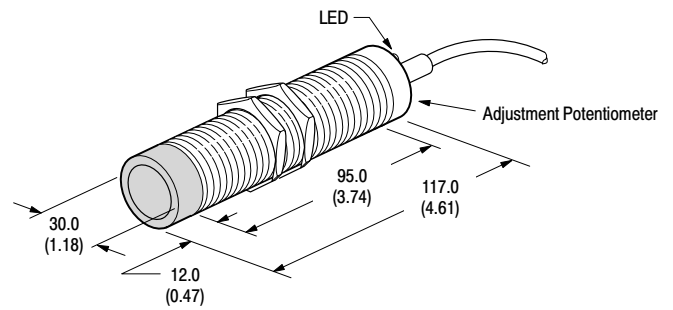

## Accessories

Description	Part Number
<b>Mounting Brackets</b>	
Right Angle	871A-BRN30
Clamp	871A-BP30
Tilt Swivel	60-2439
<b>Conduit adaptors</b>	<b>871C-N31</b>

